



ROLLER BEARINGS

The accuracy of information contained in this publication has been reviewed with maximum care; however, we do not assume any liability for any direct, indirect, or consequential damages potentially arising from the use of the information specified here.



Contents

1.	PREAMBLE	3
2.	BEARING TERMINOLOGY	7
2.1	Radial bearings (fig. 2.1 and 2.2).....	7
2.2	Radial bearings (fig. 2.3 to 2.5).....	8
3.	CRITERIA FOR SELECTION AND USE OF BEARINGS	9
3.1	Types of rolling-contact bearings.....	9
3.1.1	Based on load direction.....	9
3.1.2	Separable and non-separable bearings.....	15
3.2	Criteria for selecting bearings.....	15
4.	SELECTING TYPE OF BEARING	17
4.1	Loads.....	17
4.1.1	Radial loads.....	17
4.1.2	Axial loads.....	18
4.1.3	Combined loads.....	18
4.1.4	Torque load.....	20
4.2	Available space.....	20
4.3	Revolutions.....	21
4.4	Precision of operation.....	22
4.5	Alignment.....	22
4.6	Sliding axial movement.....	23
4.7	Support rigidity.....	25
4.8	Installation options.....	26
4.8.1	Bearings with a cylindrical bore.....	26
4.8.2	Bearings with a tapered bore.....	27
4.9	Methods of packing bearings.....	28
5.	DETERMINING BEARING SIZE	29
5.1	General information.....	29
5.2	Roller bearing reliability.....	29
5.3	Dynamic Load Capacity.....	30
5.4	Durability.....	31
5.5	Basic durability equation.....	31
5.5.1	Standard values of basic durability.....	32
5.6	Modified durability equation.....	39
5.7	Durability according ZKL.....	43
5.7.1	Fatigue load limit.....	44
5.7.2	Determining the modified durability coefficient.....	45
5.7.3	Contamination factor.....	45
5.7.4	Viscosity ratio.....	53
5.7.5	Calculating the modified durability coefficient.....	54
5.8	Equivalent dynamic load.....	56
5.8.1	Combined loads.....	56
5.8.2	Change in load magnitude at constant revolution speed.....	57
5.8.3	Change in load magnitude when rotation speed changes.....	59
5.8.4	Oscillating motion of the bearing.....	59
5.9	Effect of temperature.....	60



5.10	Static Load Rating	60
5.10.1	Equivalent static load	61
5.10.2	Bearing safety during static loading	62
6.	CRITICAL SPEED AND VIBRATIONS.	63
6.1	Bearing friction	63
6.1.1	Torque friction estimate	63
6.1.2	Calculating frictional torque	63
6.2	Limiting speed	65
6.2.1	Definition of ZKL limiting speed	65
6.2.2	Special operating speeds	67
6.3	Vibrations in the bearing	68
6.3.1	Frequency characteristics of bearings	69
6.3.2	Influence of the bearing on housing vibrations	69
7.	BEARINGS – GENERAL DATA	71
7.1	Bearing design data	71
7.2	Main dimensions	71
7.2.1	ISO dimension plans	71
7.2.2	Accuracy of bearings	73
7.2.3	Inner clearances of bearings	87
7.3	Roller bearings materials	94
7.3.1	Materials of bearing rings and rolling bodies	94
7.3.2	Materials for production of cages	95
7.3.3	Other materials	96
7.4	Cages	96
7.5	Shield and seals	98
7.6	Designation of roller bearings	98
7.6.1	Standard bearing version	100
7.6.2	Full designation of bearings	100
7.7	NEW FORCE bearings	109
7.8	Technical support	113
8.	Bearing applications	115
8.1	Arrangement of bearings	115
8.1.1	Location with axially free and axially guiding bearing	115
8.1.2	Symmetrical arrangement of bearings	115
8.1.3	Prestressed location	115
8.2.1	Radial security of bearings	119
8.2.3	Axial security of bearings	126
8.3	Seal	128
8.3.1	Contact-free sealing	128
8.3.2	Friction sealing	129
8.3.3	Combined seals	130
9.	BEARING LUBRICATION	131
9.1	Types of lubrication	131
9.2	Grease lubrication	132
9.2.1	Composition of grease lubricants	132
9.2.2	Basic grease characteristics	133
9.2.3	Miscibility	133
9.2.4	Amount of lubricant	133
9.2.5	Re-lubrication	134



9.3	Oil lubrication	138
9.3.1	Oil lubricants	138
9.3.2	Changing oil	139
9.4	Lubrication using solid lubricants	140
10.	ASSEMBLY AND DISASSEMBLY OF BEARINGS	141
10.1	General information	141
10.2	Assembly worksite	141
10.3	Work procedures	141
10.4	Preparation of bearings for assembly	141
10.5	Preparation of location components for assembly	142
10.6	Assembly of bearings with cylindrical bore	144
10.6.1	Cold assembly	144
10.6.2	Hot assembly	145
10.7	Assembly of bearings with tapered bore	146
10.8	Disassembly of bearings with cylindrical bore	147
10.9	Disassembly of bearings with tapered bore	149
10.10	Storage of bearings	151
10.10.1	Storage period	151
11.	BEARING DEFECTS AND DAMAGE	153
11.1	Main types of damage	153
12.	PRODUCT DATA - CONTENT	159
12.1	SINGLE ROW BALL BEARINGS	163
12.2	ANGULAR CONTACT BALL BEARINGS	221
12.3	DOUBLE ROW SELF ALIGNING BALL BEARINGS	263
12.4	CYLINDRICAL ROLLER BEARINGS	279
12.5	SPHERICAL ROLLER BEARINGS	381
12.6	TAPERED ROLLER BEARINGS	419
12.7	THRUST BALL BEARINGS	459
12.8	CYLINDRICAL ROLLER THRUST BEARINGS	487
12.9	SPHERICAL ROLLER THRUST BEARINGS	503
12.10	SPLIT ROLLER BEARINGS	521
12.11	BEARINGS FOR RAILWAY APPLICATIONS	537
12.12	SPECIAL ROLLER BEARINGS	557
12.13	BEARING HOUSINGS AND ACCESSORIES	595



ZKL

ZKL

NU 1024 M

GK



CZECH



1. PREAMBLE

ZKL Group, with headquarters in the Czech Republic, is a manufacturer and supplier of rolling-contact bearings. ZKL Group was established in 1999, when the Czech bearing industry integrated with over sixty years' tradition providing research, development, manufacturing, and sales of ZKL bearings. Manufacturing of ZKL personally-designed bearings began in 1947. The Rolling-Contact Bearing Research Institute was established in 1953 and was integrated into the new group as ZKL – Research and Development. It participated jointly with individual Group manufacturing plants to begin production of a large variety of bearings, which is constantly being expanded and upgraded to meet the needs of even the most demanding customers. Since then, ZKL operations expanded globally. The ZKL trademark was registered in 1954 and is protected in 53 countries.

Innovation and expansion of the range of rolling-contact bearings within the group is achieved through personal Research and Development. Bearing designs are developed with the support of the latest, high-performance CAD programs and computer programs using the method of finite elements. Manufacturing plants are also continuously upgraded and equipped with numerically controlled technology. One of the latest results of personal research and development within the group, in cooperation with customers and university research departments, is the introduction of a new generation of rolling-contact bearing production, designated as NEW FORCE. These bearings are characterized primarily by their higher dynamic load capacity, resulting from a comprehensive solution of technical development, including new bearing design methods, MKP optimization of bearing internal designs, higher guaranteed bearing material parameters, new technologies and manufacturing process.

The ZKL Group established a Quality Management System in all processes affecting bearing quality, which is certified according to EN ISO 9001:2008. Automobile industry suppliers use a system according to ISO/TS 16 949:2002.

The main ZKL rolling-contact bearing catalogue presents an overview of standard and special rolling-contact bearings and accessories that are manufactured and supplied under the ZKL brand. In individual chapters, the catalogue contains all general information about ZKL rolling-contact bearings and tables that specify the basic parameters of the entire range of ZKL bearings. Information related to specific types of bearings is provided in the expanded introduction of the chapter dedicated to the particular type of bearing. In addition to the Main Catalogue, ZKL issues additional catalogues that focus on industry-specific products, e.g. ZKL Bearings for rail vehicles or catalogues listing entirely new lines of bearings. Technical information about the special ZKL production program and special application bearings enable more frequent updating of content and improved distribution to targeted customers.

This edition of the Main Catalogue is largely revised and supplemented with new information for bearing users from series of developers, designers, sales and service personnel, who work with bearings on a daily basis. The publication is also converted into digital form. The text and bearing parameters relate to the bearings assortment and the technological state and development results at the catalogue's time of issue, i.e. at the end of 2012. Due to constant developments, we reserve the right to modify the product line to be included in the upcoming issue. Additionally, any parameters that differ in this catalogue in comparison with previous versions are the result of design developments, computational methods, new manufacturing technologies, and applied materials. Information on new products is available at the website www.zkl.cz or www.zkl.eu.

The catalogue uses units in accordance with ISO.





2. BEARING TERMINOLOGY

An illustrative description of terms that characterize individual types of bearings can be seen in the following pictures.

2.1 Radial bearings (fig. 2.1 and 2.2)

- | | |
|--|--|
| <ul style="list-style-type: none"> 1 Inner race 2 Outer race 3 Rolling element - ball, cylindrical roller, spherical roller, tapered roller 4 Cage 5 Seal, shield 6 Outer cylindrical bearing surface 7 Bearing bore 8 Cylindrical surface of inner ring flange 9 Cylindrical surface of outer ring flange 10 Snap ring groove | <ul style="list-style-type: none"> 11 Snap ring 12 Outer ring face 13 Seal groove 14 Outer ring raceway 15 Inner ring raceway 16 Bearing seal recess 17 Inner ring face 18 Installation fillet 19 Bearing mean diameter 20 Bearing width 21 Guiding flange 22 Support flange 23 Contact angle |
|--|--|

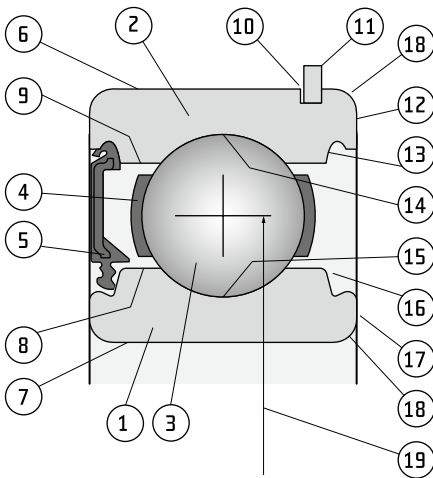

Fig. 2.1

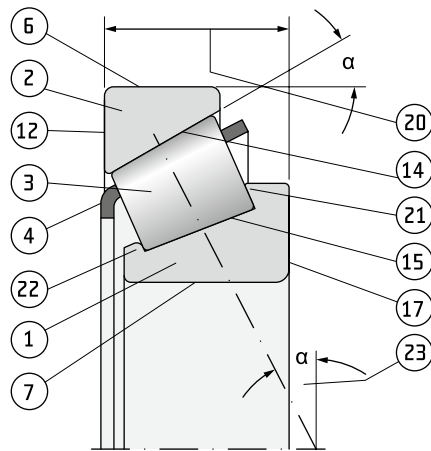

Fig. 2.2

2.2 Radial bearings (fig. 2.3 to 2.5)

- 1 Shaft ring
- 2 Cage with rollers
- 3 Housing ring
- 4 Housing ring with spherical bearing surface
- 5 Spherical housing ring

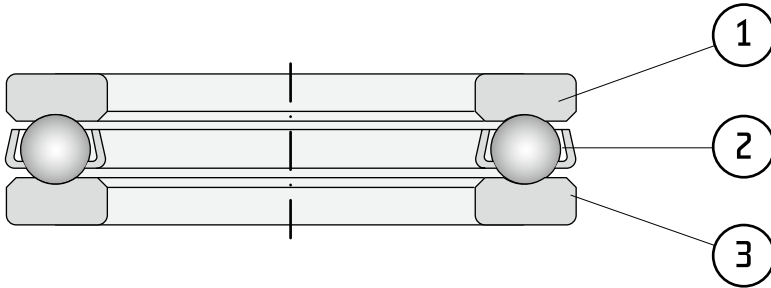

Fig. 2.3

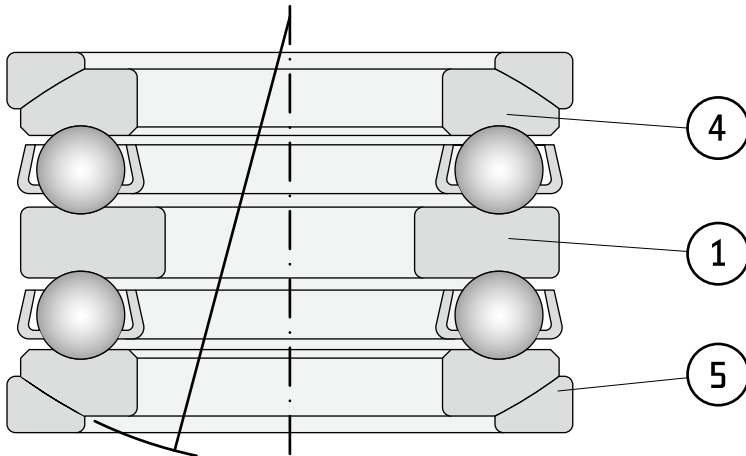

Fig. 2.4

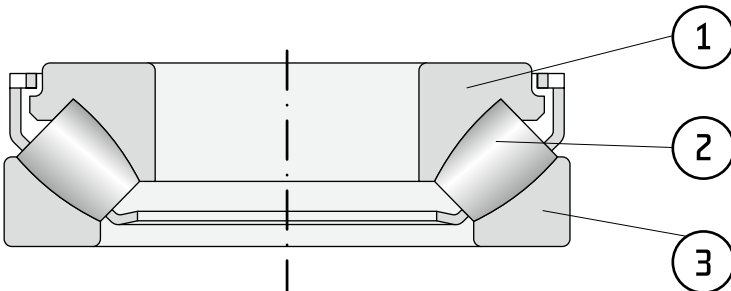

Fig. 2.5

3. CRITERIA FOR SELECTION AND USE OF BEARINGS

Rolling-contact bearings are an indispensable component of machinery, which are constantly subjected to the process of innovation. They enable mutual rotational motion of machine parts, while simultaneously transferring acting forces. They usually consist of two rings, roller-bearing cases, and a cage. Grease and packing elements are also an integral component of rolling-contact bearings. Proper rolling-contact bearing operation thus requires not only the selection of the proper type and size of bearing, but also the appropriate method of lubrication, heat dissipation, corrosion protection, and design to prevent entry of contaminants into the housing. The housing design as well as bearing connection dimension tolerances and supplemental lubrication method must be adequate. The correct installation, disassembly or de-installation procedure must also be designated to ensure proper bearing operation. A service manual and maintenance instructions should be provided in cases of complicated housing designs and where high operating reliability are needed.

These principles must particularly be observed in housings in which bearing price, high reliability, or costs associated with bearing installation and economic losses due to shutdown of equipment play a significant role. Such housings require a highly qualified approach in the design phase with the use of computations and testing.

3.1 Types of rolling-contact bearings

ZKL Company manufactures a full range of bearings, from which the designer can choose the bearings that best meet the specific requirements.

3.1.1 Based on load direction

Rolling-contact bearings are generally divided according to the direction of force, for whose transfer they are predominantly designed, into two basic groups:

- Radial bearings**
- Axial bearings**

There is no exact difference between the two groups, however, because the majority of radial bearings can also capture axial forces and certain types of axial bearings also radial forces. This division, however, is important for determining the load-bearing capacity of bearings. The load-bearing capacity in radial bearings specifies the magnitude of radial forces, whereas in axial bearings the value refers to axial forces.

We divide bearings, according to shape, into ball (single-point contact) bearings and roller (line contact) bearings. Contact in ball bearings theoretically occurs at a single point, hence the designation "single-point contact bearings." In roller, spherical, tapered roller, and needle roller bearings, contact occurs in a line or straight line, resp., thus they are commonly designated as straight-line (vector) or line-contact bearings.

The following overview provides a classification of individual bearing types based on this characteristic.

Single-point contact bearings

- Single-row ball bearings(fig. 3.1)
- Single-row angular-contact ball bearing(fig. 3.2)
- Double-row angular-contact ball bearing(fig. 3.3)
- Four-point contact bearing(fig. 3.4)

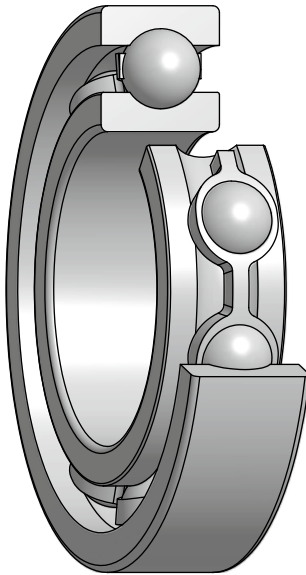

*Single-row ball bearings
(fig. 3.1)*

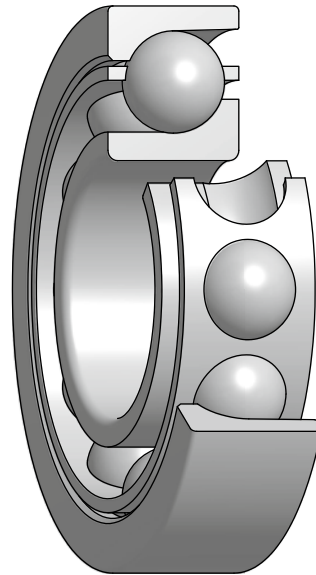

*Single-row angular-contact ball bearing
(fig. 3.2)*

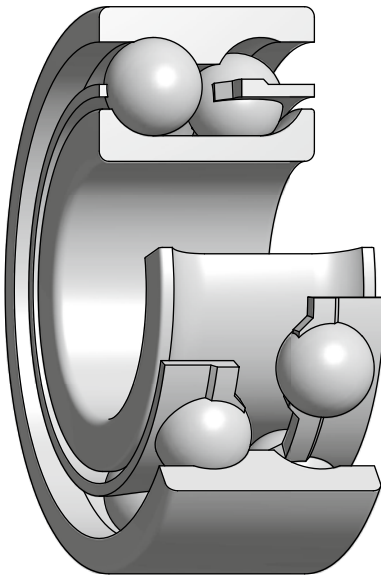

*Double-row angular-contact ball bearing
(fig. 3.3)*

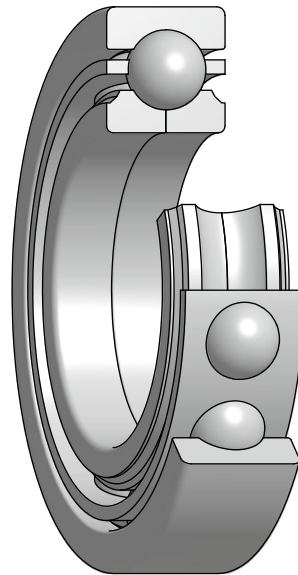

*Four-point contact bearing
(fig. 3.4)*

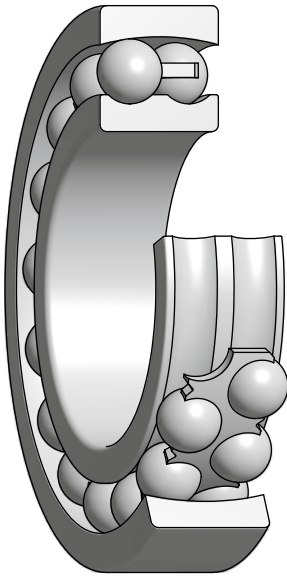

*Double-row, self-aligning ball bearing
(fig. 3.5)*

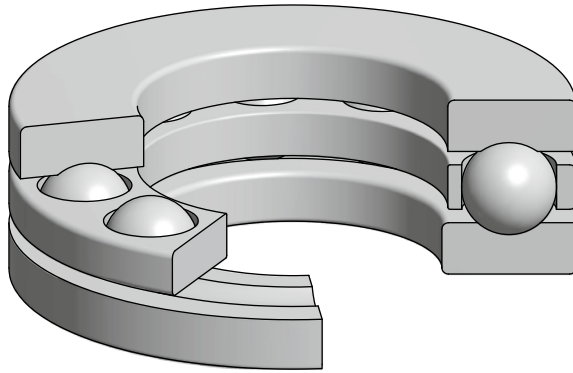

*Single direction thrust ball bearings
(fig. 3.6)*

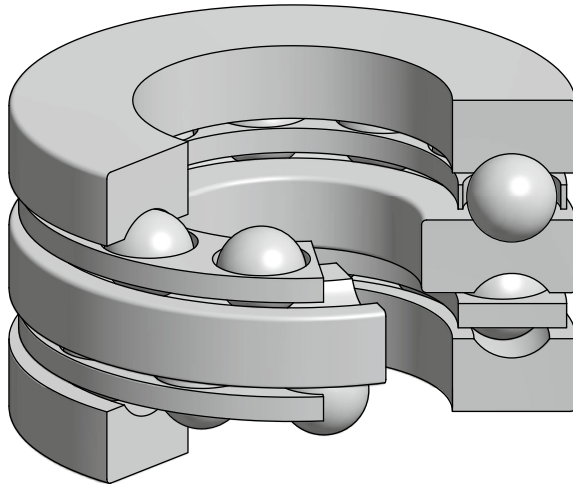

*Double direction thrust ball bearings
(fig. 3.7)*

Double-row, self-aligning ball bearing (fig. 3.5)
 Single direction thrust ball bearings (fig. 3.6)
 Double direction thrust ball bearings (fig. 3.7)

Line-contact bearings

Single row cylindrical roller bearing (fig. 3.8)
 Double row cylindrical roller bearing (fig. 3.9)
 Single row full complement cylindrical roller bearing (fig. 3.10)
 Double row full complement cylindrical roller bearing (fig. 3.11)
 Tapered roller bearing (fig. 3.12)
 Double row tapered roller bearing (fig. 3.13)
 Double row spherical roller bearing (fig. 3.14)
 Thrust cylindrical roller bearing (fig. 3.15)
 Thrust spherical roller bearing (fig. 3.16)

We separate each type of roller bearing then into several types according to dimensions and design variations. Specific information on characteristics of individual types of bearings is available in the sections of text provided before the tables of individual bearings.

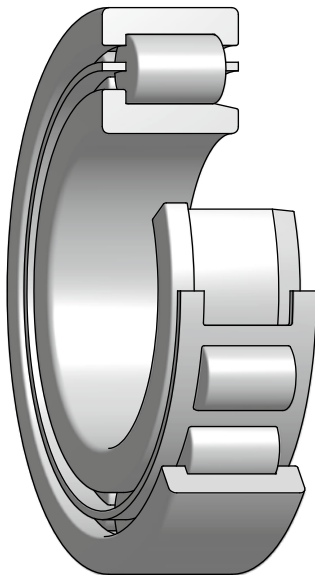

*Single row cylindrical roller bearing
(fig. 3.8)*

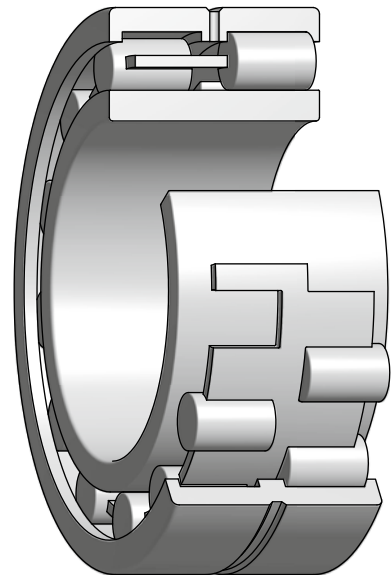

*Double row cylindrical roller bearing
(fig. 3.9)*

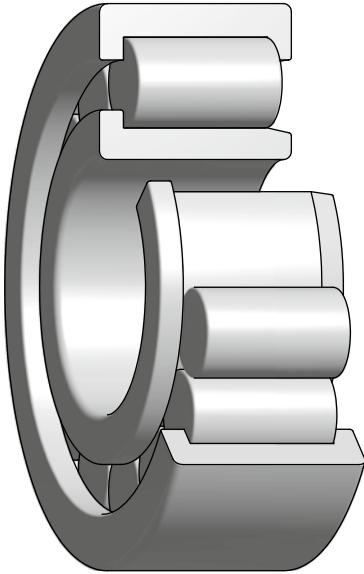

*Single row full complement cylindrical roller bearing
(fig. 3.10)*

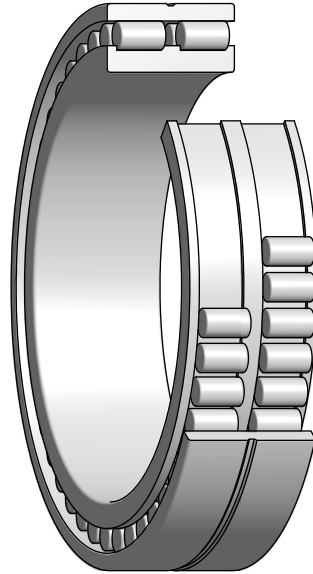

*Double row full complement cylindrical roller bearing
(fig. 3.11)*

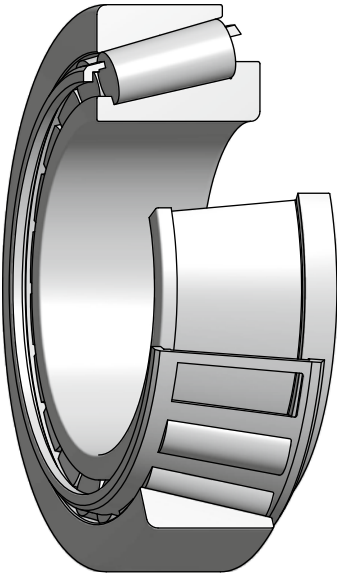

*Tapered roller bearing
(fig. 3.12)*

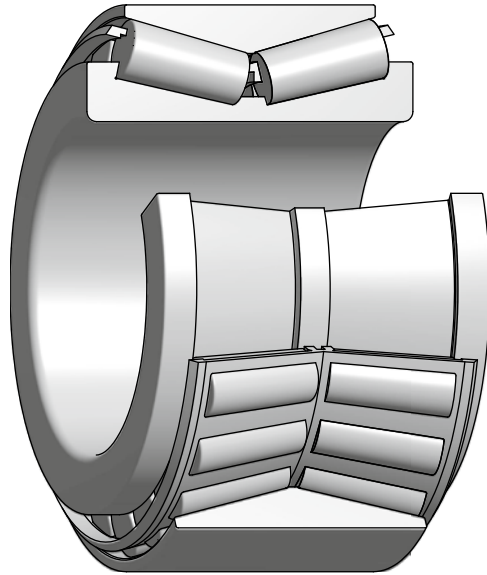

*Double row tapered roller bearing
(fig. 3.13)*

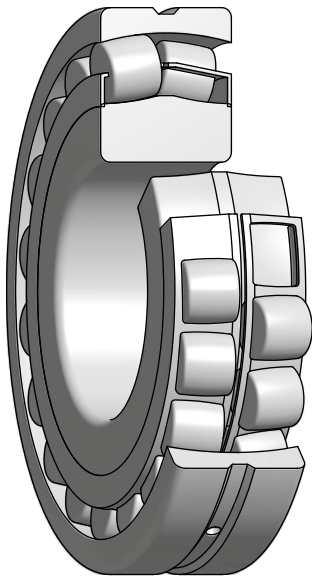

*Double row spherical roller bearing
(fig. 3.14)*

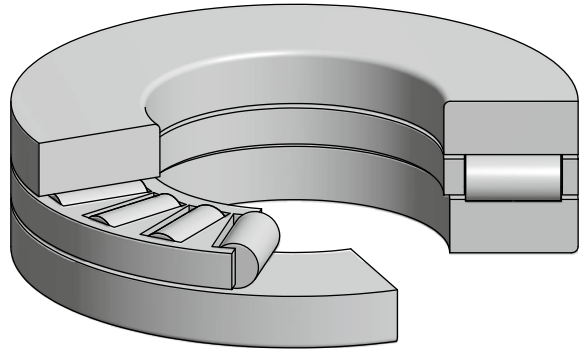

*Thrust cylindrical roller bearing
(fig. 3.15)*

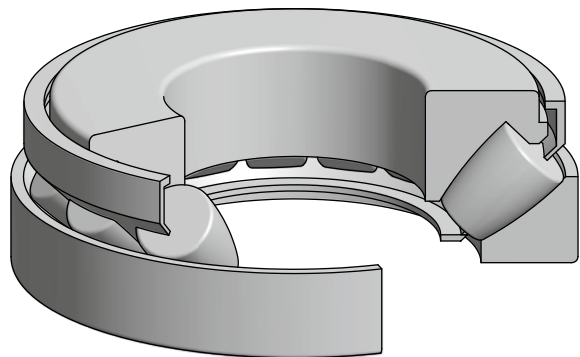

*Thrust spherical roller bearing
(fig. 3.16)*

3.1.2 Separable and non-separable bearings

Separable bearings allow separate installation of both rings, which is of particular advantage when installing both rings with an overlap. Sequential installation of individual parts can also be used in certain complex housings and assembly units. Separable bearings are, e.g. four-point contact bearings, double-row ball bearings with split inner ring, roller bearings, tapered roller bearings, thrust ball bearings, thrust roller bearings, and spherical roller thrust bearings.

In contrast, non-separable bearings include, e.g. single row ball bearings, single row angular-contact ball bearings, self-aligning ball bearings, and double-row spherical roller bearings.

3.2 Criteria for selecting bearings

The ZKL production program offers a full range of bearings, from which the designer can choose the bearings that best meet the specific requirements. The bearing type and size are generally chosen according to its loading capacity with consideration to its operating conditions and expected bearing service life. To determine the proper type of bearing thus requires a thorough knowledge of the loading capacity of the bearing during operation. Proper principles for selecting, fitting, and installing them must be followed, but it also requires knowledge of the prerequisites for which the proposed results apply. In the following chapters, we thus present general principles for selecting and using contact-roller bearings, which may be used by drafting engineers in the bearing design process. The chapters are organized in logical consecutive order. The technical part of the publication contains important information regarding calculations, design data, housing, lubrication designs, as well as installation and removal information on rolling-contact bearings. The table provides a list of currently manufactured ZKL rolling-contact bearings with main dimensions and functional parameters.

Even though they list detailed information, this publication is unable to provide full information on all housings for their wide varieties of application. We therefore recommend that complex housing designs be consulted with ZKL technical and consultation service specialists.



4. SELECTING TYPE OF BEARING

Each type of bearing is characterized by specific properties unique to the given design and dimensions, which determine its suitability for the given type of application. Ball bearings for example are characterized by low friction and low noise. They are designed for translating medium-large radial as well as axial loads. They may be manufactured at higher precision enable them to operate at higher rpms. Due to their properties and affordability, they are among the most common types of bearings used. In contrast, spherical-roller bearings are designed for housings under high loads and are capable of compensating to a certain extent misalignments. They are thus particularly suitable for industrial use. It is thus important, when selecting the type of bearing, to consider various influences and to evaluate them according to their measure of importance for the given housing. The selection of a standard bearing is influenced particularly by:

- Load
- Available space
- Revolutions
- Precision of operation
- Alignment
- Slide-able axial movement
- Housing rigidity
- Installation and de-installation options
- Sealing methods

4.1 Loads

4.1.1 Radial loads

Bearings designed primarily for transferring radial loads are called radial bearings (fig. 4.1). They have a nominal contact angle of $\alpha \leq 45^\circ$. Line contact bearings are more suitable for higher radial loads than single-point contact bearings, and bearings with a full number of rolling bodies have a higher load capacity than corresponding bearings with a cage.

Ball bearings are designed for small and medium-large loads. N- and NU-type ball bearings can only be burdened radially. Different type radial bearings can transfer both radial as well as axial loads.

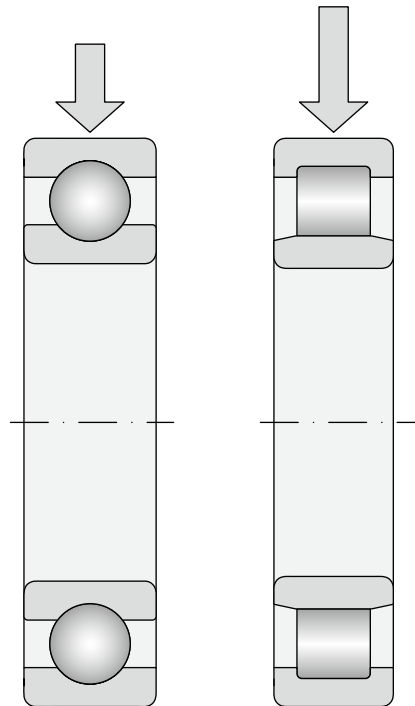

Fig. 4.1

4.1.2 Axial loads

Bearings designed mainly for axial loads (thrust ball bearings) have a contact angle $\alpha > 45^\circ$.

Axial ball bearings and angular contact thrust ball bearings may, depending on the design, transfer axial loads in one or both directions (fig. 4.2a). In cases of extremely high axial loads, a thrust cylindrical roller or thrust roller bearings (fig. 4.2b). Other thrust bearings are only suitable for axial loads. Double direction bearings are designed for bi-directional axial loads.

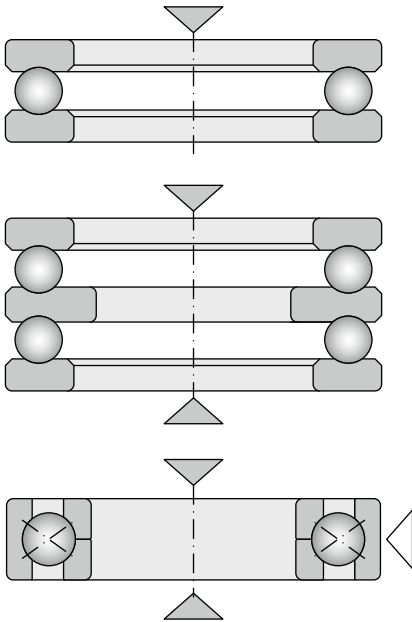

Fig. 4.2a

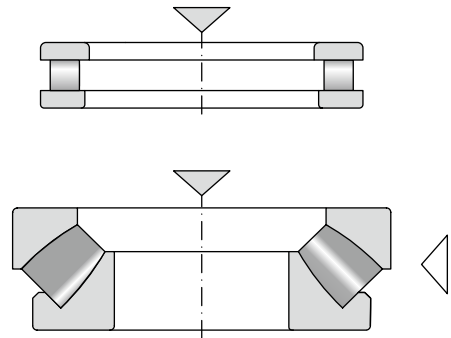

Fig. 4.2b

4.1.3 Combined loads

Combined loads are composed of simultaneously acting radial and axial loads.

Axial load capacity of a bearing depends on the angle of contact. The larger the angle, the larger the axial load bearing capacity of the bearing. Larger axial clearance in single row ball bearings increases their load bearing capacity. Single and double row angular contact ball bearings or tapered roller bearings are best for capturing combined loads (fig. 4.3a). Combined loads can also be borne by double row spherical roller bearings, thrust ball angular-contact bearings, and to a limited extent, also spherical roller thrust bearings. Self-aligning ball bearings, NJ, NUP, or NJ roller-contact bearings and NU bearings with HJ attachment rings (fig. 4.3b) can be used for combined loads with a relatively small axial component.

Single row angular contact ball bearings, tapered roller bearings, NJ roller-contact bearings, and NU+HJ and axial spherical roller bearings can only transfer unidirectional axial loads. If the arrangement of the active load changes, an additional bearing must be used. Combined single row angular contact ball bearings or single row tapered roller bearings are provided for best capturing such combined loads.

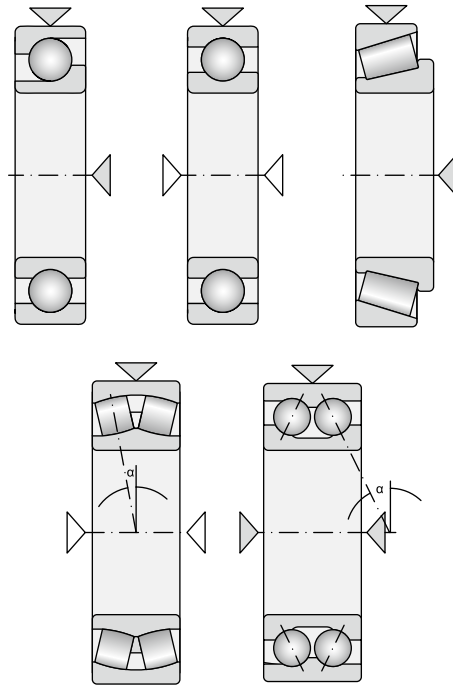

Fig. 4.3a

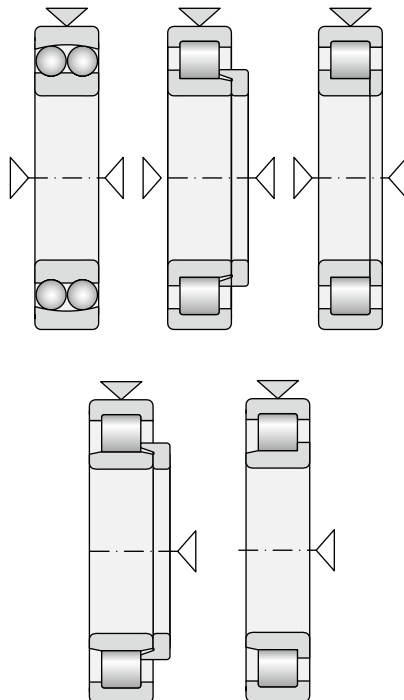
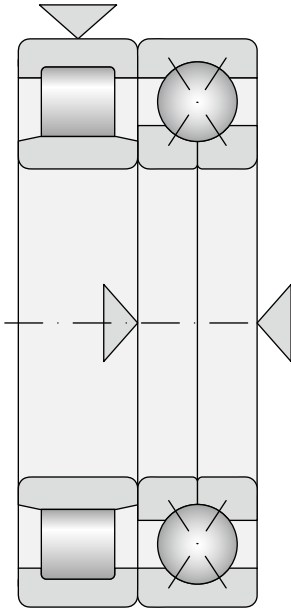

Fig. 4.3b



In addition to thrust bearings, ball bearings or four-point ball bearings can be used for capturing axial forces (fig. 4.4)

4.1.4 Torque load

If the load application point lies outside of the bearing axis, then an overturning torque is created. The use of a radial double row bearing or a double row angular contact ball bearing usually suffices for its transfer. The use of a pair of single row angular contact ball bearings or tapered roller bearings installed back-to-back in pairs (into an "O"), however, are preferred (fig. 4.5).

4.2 Available space

In certain circumstances, it presents as a limiting condition for the bearing design. In small-diameter housing, the single row ball bearing is most often

Fig. 4.4

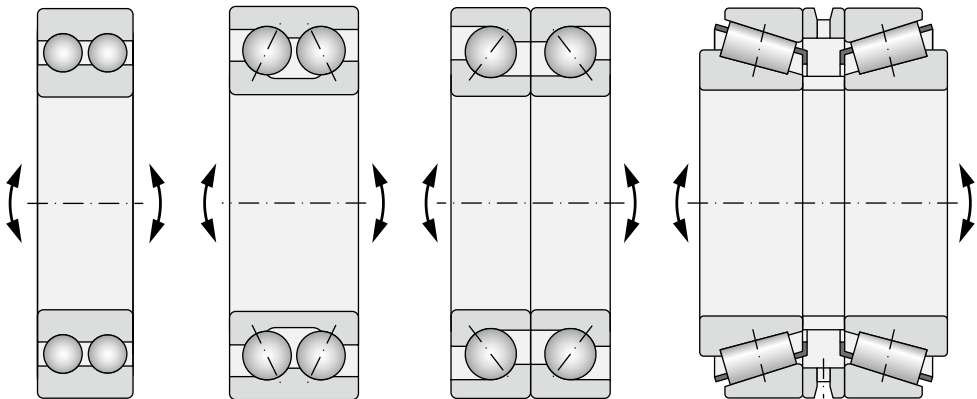

Fig. 4.5

applied (fig. 4.6). Cylindrical roller, spherical roller, and taper roller bearings may optionally be used for large diameter shafts (fig. 4.7). Various types of bearings also allow for a variety of types with various bearing section strengths. Where there is limited space in the radial or axial direction, bearings with a suitable cross-section are selected (fig. 4.8).

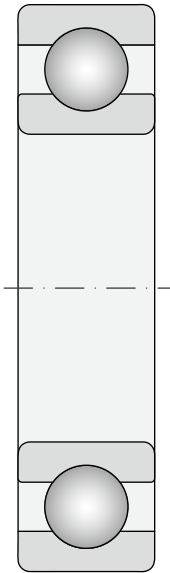

Fig. 4.6

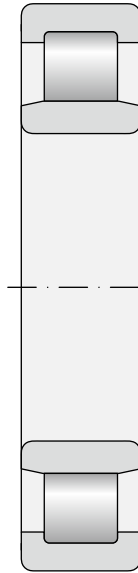

Fig. 4.7

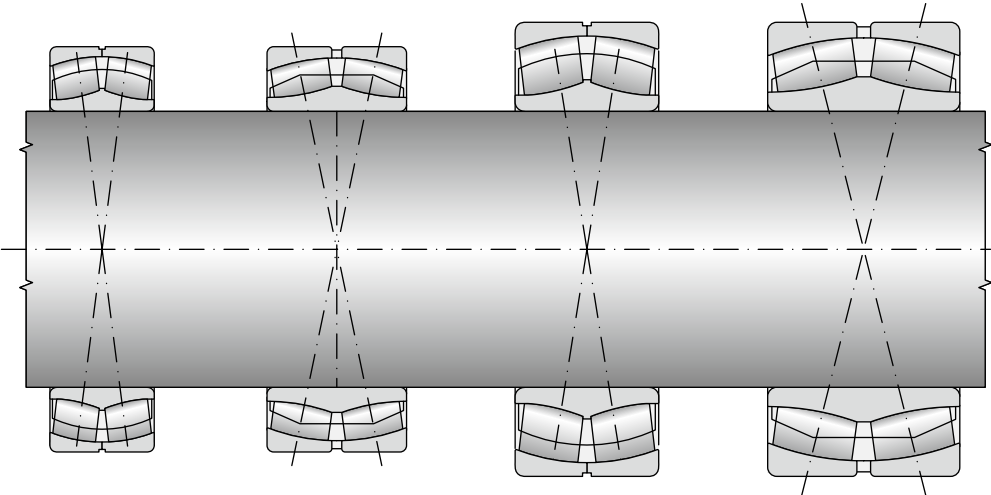
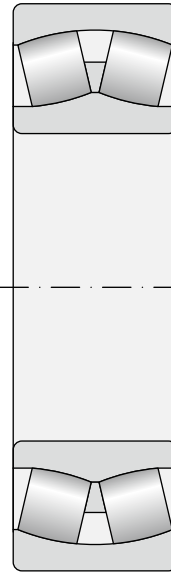
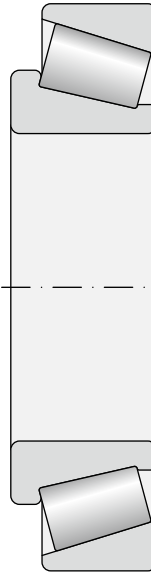

Fig. 4.8

4.3 Revolutions

Low-friction bearings should be used in housing subjected to high revolutions. Among such bearings are single-row ball bearings for purely radial loads. Angular-contact ball bearings in combined loads equally generate little heat. Both types of bearings are thus the most suitable for high revolution applications. Single row cylindrical roller bearings are additionally suitable for high revolutions.

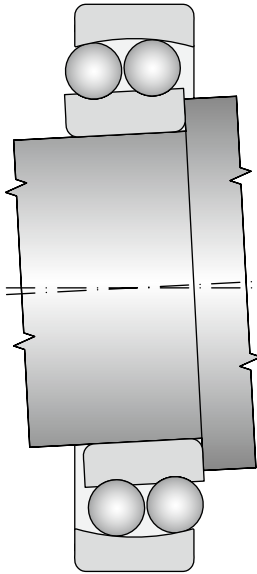

Fig. 4.9a

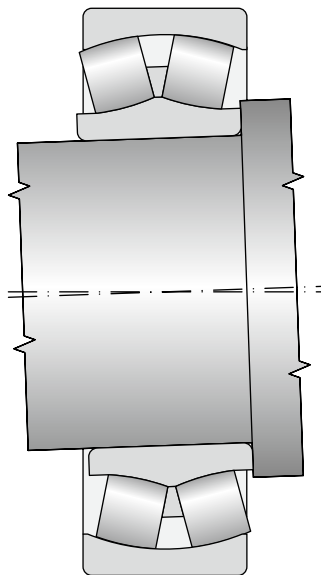

Fig. 4.9b

From a design aspect, the rpms in thrust bearings are always lower than those of radial bearings.

4.4 Precision of operation

Bearings with normal diameter precision and operation (precision class P0) are sufficient for the most housing. In more demanding housing, e.g. for fitting machine tool spindles, bearings with higher precision must be used. Such bearings are designated by precision classes P6, P6E, P6X, P5, P5A, P4, P4A, P2, SP, UP. In the text, which is located at the beginning of individual tables, you are provided with more detailed information about precision classes, in which individual types are produced.

4.5 Alignment

With regard to manufacturing inaccuracies and spindle deflections, mutual inclinations of bearing rings occur in the housing. This phenomenon should be expected and it is necessary to select bearings that compensate for the misalignment and installation inaccuracy. Self-aligning ball bearings (fig. 4.9a), double row spherical roller bearings (fig. 4.9b), and thrust spherical roller bearings (fig. 4.9c), are such types. The angle of inclination of such bearings depends on the type, size, and load. High rigidity bearings, such as cylindrical roller bearing or ball bearings, can compensate for small misalignments, assuming that they are unburdened.

4.6 Sliding axial movement

A fixed axial and free axial bearing is general used for supporting shafts, while the fixed axial bearing provides shaft guidance in both directions and the free axial bearing compensation for the axial change in length and thermal expansion. If axial displacement of thermally expanding components is prevented, then uncontrolled axial overloading of firmly fixed bearings may result.

Bearings that can carry combined loads are most suitable for capturing axial forces. Bearings that are best able to afford axial movement are NU and N cylindrical roller bearings (fig. 4.10). If ball or cylindrical roller bearings are used as free bearings, then one of the bearing rings (usually the outer) must be attached freely (fig. 4.11).

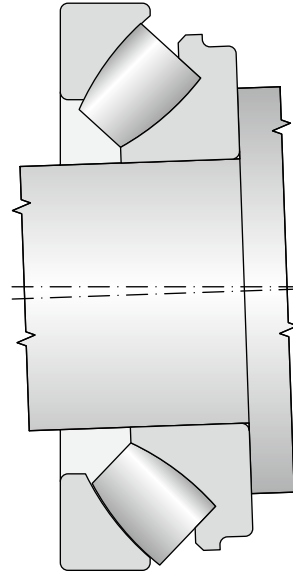

Fig. 4.9c

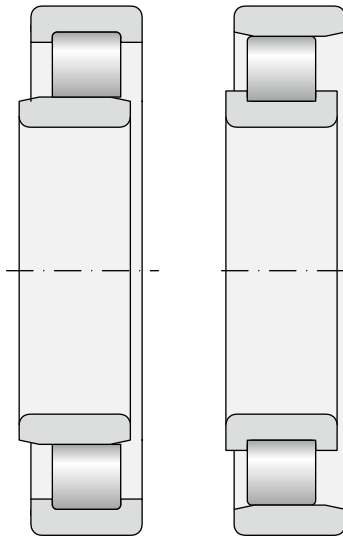

Fig. 4.10

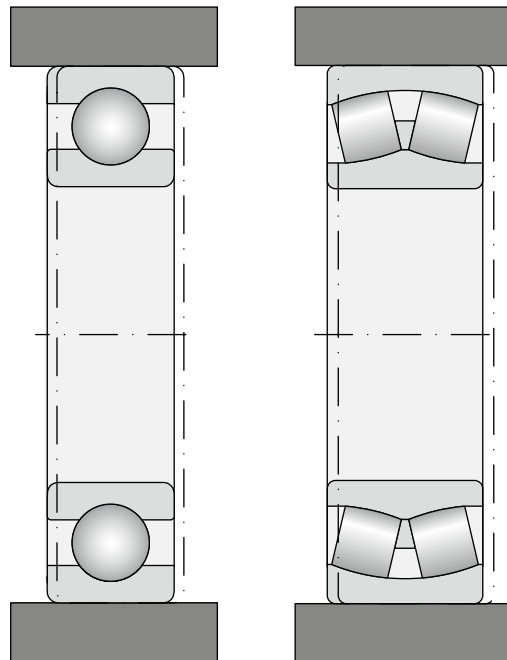

Fig. 4.11

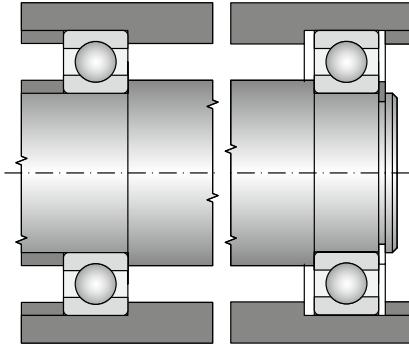

Fig. 4.12a

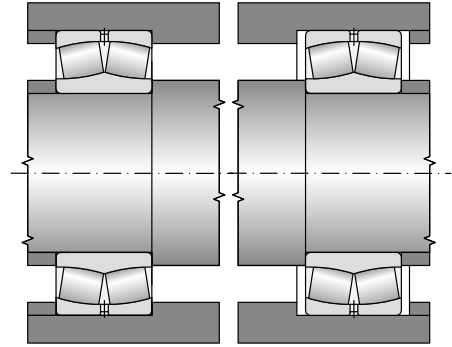

Fig. 4.12b

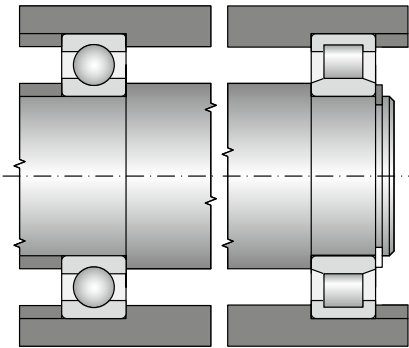

Fig. 4.12c

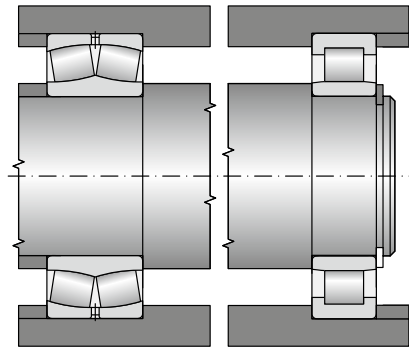

Fig. 4.12d

Examples of axially guided and free axial bearing supports are illustrated in figures 4.12a to 4.12

- a) Axially guided ball bearing, free axial ball bearing
- b) Axially guided spherical-roller bearing, free axial cylindrical roller bearing
- c) Axially guided ball bearing, free axial NU cylindrical roller bearing
- d) Axially guided spherical-roller bearing, free axial NU roller-contact bearing
- e) Axially guided double-row angular-contact ball bearing, axially free NU cylindrical roller bearing
- f) Axially guided four-point contact ball bearing and an NU cylindrical roller bearing, free axial NU roller-contact bearing
- g) Axially guided double-row tapered-roller bearing, free axial NU cylindrical roller bearing
- h) Axially guided NUP cylindrical roller bearing, free axial NU cylindrical roller bearing

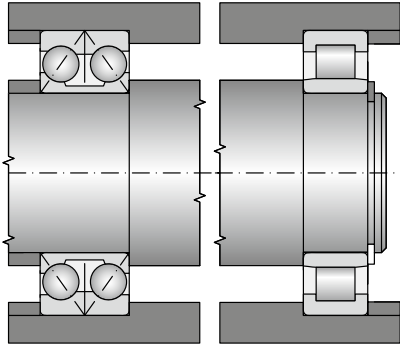

Fig. 4.12e

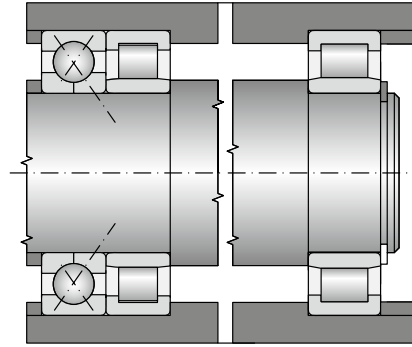

Fig. 4.12f

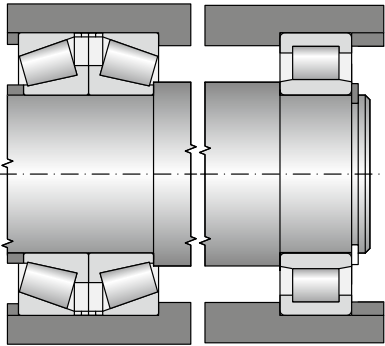

Fig. 4.12g

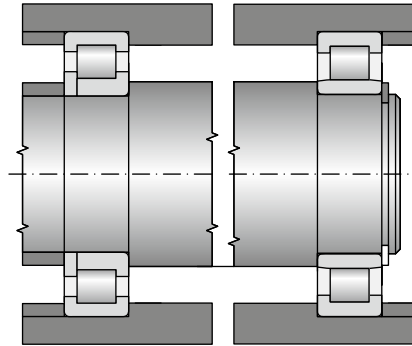

Fig. 4.12h

4.7 Support rigidity

The support rigidity expresses the force required to achieve a defined deflection when using a flexible support. High rigidity is demanded, for example when supporting the main spindle in machine tools and pinion gear sets.

The rigidity of line-contact bearings such as, e.g. cylindrical roller bearing and tapered roller bearings is higher than in ball bearings due to the contact ratios between the rolling elements and raceways.

The bearings are pre-stressed to increase their rigidity.

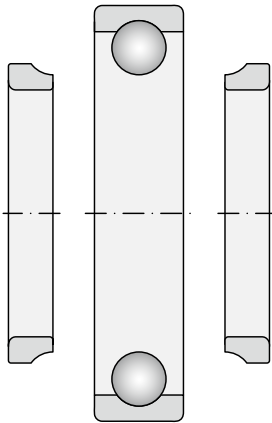

Fig. 4.13a

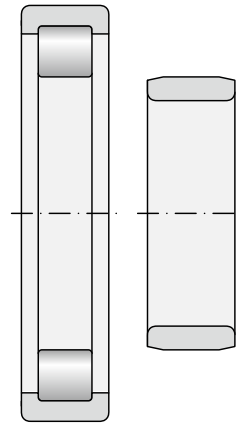

Fig. 4.13b

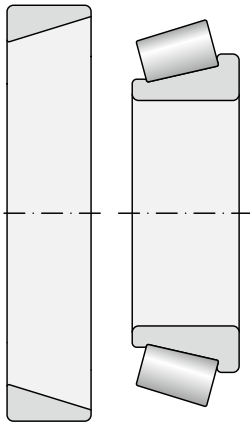

Fig. 4.13c

4.8 Installation options

4.8.1 Bearings with a cylindrical bore

These bearings are more easily installed and removed, if they can be taken apart. This particularly applies for bearings within a fixed housing. Separable bearings are also suitable for use where frequent installation and removal are required. A ring with roller elements may be installed separately, irrespective of the second ring (fig. 4.13a – 4.13c).

- four-point contact ball bearing (obr. 4.13a)
- NU cylindrical roller bearing (fig. 4.13b)
- tapered-roller bearing (fig. 4.13c)

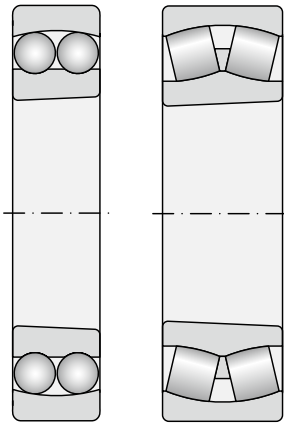

Fig. 4.14

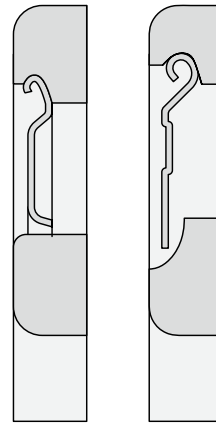

Fig. 4.15

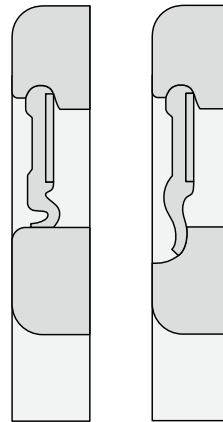

Fig. 4.16

4.8.2 Bearings with a tapered bore

Bearings with a tapered bore (fig. 4.14) are installed on a conical or cylindrical shaft using an adapter sleeve or withdrawal sleeve. The radial clearance of bearings can be set during installation. Installation and removal of bearings is relatively simple.



4.9 Methods of packing bearings

ZKL Company provides a full range of roller bearings with shields or with contact-seal on one or both sides. The bearings use contact (friction) seal (fig. 4.15) or are shielded (fig. 4.16) using non-contact (touch-less) seal. Bearings with seal on both side are filled with grease and do not require additional greasing during operation. The use of such bearings makes it possible to design economical and spatially undemanding housing. In other instances, care must be taken to monitor the structure of other components to prevent unwanted leaking of grease and entry of contaminants into the bearings.

5. DETERMINING BEARING SIZE

5.1 General information

A properly installed and lubricated roller-contact bearing will operate under normal conditions, i.e. absent extreme speeds and temperatures, until it fails due to fatigue of materials at acting surfaces. Repeated stress on the contact surfaces between roller-contact surfaces and rings will manifest after a certain period depending on the magnitude of load as a stress fracture. This will expand until a part of the bearing ring material or roller element material breaks off (pitting) and causes failure. Many bearings are also discarded for other reasons than material fatigue, but these failures can be avoided if the bearing is treated properly, if it is properly installed, lubricated, and overloading is avoided.

When a certain number of identical bearings are tested for fatigue under specified operating conditions (load and rpm), there is a large variance of durability between individual bearings. In a group of 30 or more bearings, the ratio between the shortest and longest durability can be 20-fold or more. A durability variance curve can be drawn for each tested group of bearings that illustrates the relationship between the durability and the number of bearings, which were discarded.

The required bearing size is determined on the basis of externally acting forces and based on the durability and reliability demands of the seated bearing. The size, direction, purpose, and nature of the bearing load as well as the revolution operating speed are determinant when selecting the bearing type and size. Meanwhile, other special or important conditions of each individual case must be considered, e.g. operating temperature, spatial allowances, ease of installation, lubrication requirements, packing, etc., which can affect the selection of the most suitable bearing. Various types of bearings may, in many cases, be suitable for the given specific conditions.

In terms of the action of external forces and the function of the bearing in the respective node or unit, we distinguish two types of roller bearing loads in bearing technology:

- If the bearing rings turn in relation to one another and the bearing is exposed, under such conditions, to external forces (which applies for the majority of bearing applications), we refer to this as a dynamic bearing load,
- If the bearing rings do not turn in relation to one another or turn very slowly, the bearing transmits oscillating motion, or external forces act for shorter period than the time of one bearing revolution, we refer to this as a static bearing load.

The durability limited by failure of a particular bearing component (bearing rings, roller elements, cage, lubricant and seal) is, in the first case, decisive for calculating bearing safety. In the second case, permanent deformities of functional surfaces at contact points between rolling elements and orbits is decisive.

5.2 Roller bearing reliability

The reliability of a group of apparently identical roller bearings, operating under identical conditions, is the percentage of the group, expected to achieve or exceed the specified durability.

The reliability of an individual roller bearing is the probability that the bearing will achieve or exceed the specified durability.

The equation for calculating durability includes the effect of stress induced by external loads, lubrication, and surface kinematics at the site of rolling contact. Including the impact of the comprehensive system of stress on bearing durability makes it possible to better anticipate the actual manner, in which a bearing behaves within a specific housing. International standards, such as e.g. ISO 281, are based on the theory of material fatigue at the site of rolling contact. One must keep in mind that a complete bearing can be considered as a system, the individual components of which (bearing rings, rolling elements, cage, lubricant and seal) have the same effect on durability and, in certain cases, are even a decisive factor in determining the bearing durability during operation. The optimal operating durability is theoretically achieved when all of the components achieve the same durability. In other words, the calculated durability corresponds to the actual operating durability if the operating durability of related components is at least as long as the calculated bearing durability. Related components in such case are the cage, seal and lubricant. The most important factor in practise is metal fatigue.

5.3 Dynamic Load Capacity

Dynamic load capacity is, according to ISO 281:1990, a constant invariable load that a bearing can theoretically carry at a basic durability of one million revolutions.

The dynamic load capacity C_r for radial bearings relates to constant, invariable, entirely radial loads. For thrust bearings, the dynamic load capacity C_a relates to the invariable, purely axial load acting in the bearing's axis.

The dynamic load capacity C_r and C_a , whose magnitude depends on the bearing dimensions, the number of rolling elements, the bearing material and design, is provided in the table for each bearing. The dynamic load capacity values were determined in accordance with ISO standard 280. These values are verified on testing equipment and confirmed in operating results.

The numeric values specified in this catalogue apply for chrome steel bearings, heat treated to a minimal hardness of 58 HRC and normal operating conditions. NEW FORCE bearings display, among others, improved material properties and advanced manufacturing processes. To determine the dynamic load capacity in these bearings, thus requires the use of correction factors according to ISO 281. More information about these bearings is available in separate chapter 7.7.

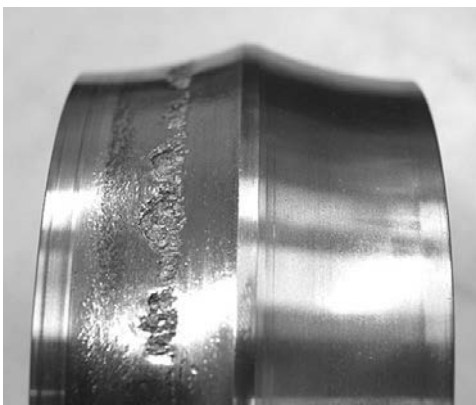

Fig. 5.1 Photo-illustration of fatigue damage on the raceway



Fig. 5.2 Photo-illustration of fatigue damage on the raceway

5.4 Durability

It is the number of revolutions that a bearing lasts, before fatigue of one of its components occurs, which manifests as flaking of material. It is expressed either as the total number of revolutions or operating hours, or in vehicles, by the distance travelled (number of driven km).

The material is primarily responsible for significant variance in durability in a broader range of identical bearings tested under the same conditions. No material or bearing steel is entirely homogenous and contains certain weak points. If a weak point is located on the orbit, where large load (stress) is generated, then the durability of the bearing will be small. The durability is higher where the load is decreased. Poor material has a large amount of weak points and, in all likelihood, some of them lie in areas of greatest load. The variance of durability will thus be less in poor material and larger in first-class material.

Variance of durability is also affected by manufacturing tolerances of individual components. The tolerances of roller diameters and radiuses of raceways significantly affect loads on roller surfaces. For manufacturing reasons, the radial clearance in a bearing varies within a specific tolerance, and as such, it also affects the distribution of pressure on individual roller elements. The distribution of forces within the bearing in the same manner cause expansion and decrease the orbit diameter due to the prescribed placement of rings on the shaft and within the housing.

Adherence to the prescribed material composition, its purity, and heat treatment is also an important indicator of bearing quality. Large variances in durability of large quantities of identical roller bearings, testing under identical conditions is but a natural consequence of the specified individual influences. Current research shows that even the quality of lubrication, its purity, and quantity may significantly impact bearing durability. Lubrication is taken into account in the modified durability calculation, see further.

The results of performed durability tests and practical operating experiences indicate that identical bearings, operating under identical conditions, do not achieve the same durability. The term “durability” must thus be correctly defined.

5.5 Basic durability equation

The basic durability of a bearing is mathematically defined by the durability equation, which applies for all types of bearings.

$$L_{10} = \left(\frac{C}{P} \right)^p \quad \text{or} \quad \frac{C}{P} = (L_{10})^{1/p}$$

L_{10} basic durability [10⁶ rev]

C dynamic load capacity [kN]
(the C_r and C_a values are specified in the product section of the catalogue)

P bearing equivalent dynamic load capacity [kN]
(the equations for calculating P_r and P_a are provided in the chapter Equivalent Dynamic Load Capacity and for each structural group of bearings)

p ball bearing exponent $p = 3$

. For cylindrical roller, needle roller, spherical-roller, and tapered-roller bearings $p = \frac{10}{3}$

The basic durability of a bearing is thus understood to mean the durability that 90% of bearings achieve or exceed from a set of identical bearings, working under the same operating conditions. All standard durability calculations are performed for this reliability level. Mean durability L_{50} is the durability that 50% of bearing from the same set achieve; it is about 5 times higher than the basic durability. In contrast, the durability achieved by 99% of bearings is about one fifth when compared with the basic durability. The impact of the degree of reliability on the durability calculation is specified in chapter 5.6.

Table 5.1 lists the relationship of durability L_{10} in millions of revolutions and the corresponding C/P ratio. If the revolution speed is unchanged, then the durability can be calculated using the modified equation, which expresses the basic durability in terms of operating hours:

$$L_{10h} = \left[\frac{C}{P} \right]^p \cdot \left[\frac{10^6}{60n} \right]$$

L_{10h} basic durability [h]

n revolution speed [min⁻¹]

The relationship of the C/P ratio on basic durability L_{10h} and on the revolution speed for ball bearings is specified in table 5.2 and in table 5.3 for cylindrical roller, needle, spherical-roller, and tapered-roller bearings.

In road and rail vehicle axle supports, we can express the basic durability using the modified relationship in terms of kilometres driven.

$$L_{10km} = \left[\frac{C}{P} \right]^p \cdot \frac{\pi \cdot D}{1000}$$

L_{10km} basic durability [10⁵ km]

D wheel diameter [m]

5.5.1 Standard values of basic durability

In cases, when the required durability for the given housing is not provided in advance, we can appropriately use the values provided in tables 5.4 and 5.5.

Table 5.1

C/P ratio depending on durability L_{10h}							
Ball bearings				Cylindrical roller, needle-roller, spherical-roller, and tapered-roller bearings			
L_{10} Durability	C/P	L_{10} Durability	C/P	L_{10} Durability	C/P	L_{10} Durability	C/P
$\times 10^6$ rev		$\times 10^6$ rev		$\times 10^6$ rev		$\times 10^6$ rev	
0,5	0,79	600	8,43	0,5	0,81	600	6,81
0,75	0,91	650	8,66	0,75	0,92	650	6,98
1	1,00	700	8,88	1	1,00	700	7,14
1,5	1,14	750	9,09	1,5	1,13	750	7,29
2	1,26	800	9,28	2	1,24	800	7,43
3	1,44	850	9,47	3	1,39	850	7,56
4	1,59	900	9,65	4	1,52	900	7,70
5	1,71	950	9,83	5	1,62	950	7,82
6	1,82	1 000	10,00	6	1,71	1 000	7,94
8	2,00	1 100	10,30	8	1,87	1 100	8,17
10	2,15	1 200	10,60	10	2,00	1 200	8,39
12	2,29	1 300	10,90	12	2,11	1 300	8,59
14	2,41	1 400	11,20	14	2,21	1 400	8,79
16	2,52	1 500	11,40	16	2,30	1 500	8,97
18	2,62	1 600	11,70	18	2,38	1 600	9,15
20	2,71	1 700	11,90	20	2,46	1 700	9,31
25	2,92	1 800	12,20	25	2,63	1 800	9,48
30	3,11	1 900	12,40	30	2,77	1 900	9,63
35	3,27	2 000	12,60	35	2,91	2 000	9,78
40	3,42	2 200	13,00	40	3,02	2 200	10,10
45	3,56	2 400	13,40	45	3,13	2 400	10,30
50	3,68	2 600	13,80	50	3,23	2 600	10,60
60	3,91	2 800	14,10	60	3,42	2 800	10,80
70	4,12	3 000	14,40	70	3,58	3 000	11,00
80	4,31	3 500	15,20	80	3,72	3 500	11,50
90	4,48	4 000	15,90	90	3,86	4 000	12,00
100	4,64	4 500	16,50	100	3,98	4 500	12,50
120	4,93	5 000	17,10	120	4,20	5 000	12,90
140	5,19	5 500	17,70	140	4,40	5 500	13,20
160	5,43	6 000	18,20	160	4,58	6 000	13,60
180	5,65	7 000	19,10	180	4,75	7 000	14,20
200	5,85	8 000	20,00	200	4,90	8 000	14,80
250	6,30	9 000	20,80	250	5,24	9 000	15,40
300	6,69	10 000	21,50	300	5,54	10 000	15,80
350	7,05	12 500	23,20	350	5,80	12 500	16,90
400	7,37	15 000	24,70	400	6,03	15 000	17,90
450	7,66	17 500	26,00	450	6,25	17 500	18,70
500	7,94	20 000	27,10	500	6,45	20 000	19,50
550	8,19	25 000	29,20	550	6,64	25 000	20,90

Table 5.2

C/P ratio dependent on L_{10h} durability and rotation speed n for ball bearings														
L_{10h} Durability	Rotation speed n [min ⁻¹]													
	Hod	10	16	25	40	63	100	125	160	200	250	320	400	500
100	-	-	-	-	-	-	-	-	-	1,06	1,15	1,24	1,34	1,45
500	-	-	-	1,06	1,24	1,45	1,56	1,68	1,82	1,96	2,12	2,29	2,47	2,47
1 000	-	-	1,15	1,34	1,56	1,82	1,96	2,12	2,29	2,47	2,67	2,88	3,11	3,11
1 250	-	1,06	1,24	1,45	1,68	1,96	2,12	2,29	2,47	2,67	2,88	3,11	3,36	3,36
1 600	-	1,15	1,34	1,56	1,82	2,12	2,29	2,47	2,67	2,88	3,11	3,36	3,63	3,63
2 000	1,06	1,24	1,45	1,68	1,96	2,29	2,47	2,67	2,88	3,11	3,36	3,63	3,91	3,91
2 500	1,15	1,34	1,56	1,82	2,12	2,47	2,67	2,88	3,11	3,36	3,63	3,91	4,23	4,23
3 200	1,24	1,45	1,68	1,96	2,29	2,67	2,88	3,11	3,36	3,63	3,91	4,23	4,56	4,56
4 000	1,34	1,56	1,82	2,12	2,47	2,88	3,11	3,36	3,63	3,91	4,23	4,56	4,93	4,93
5 000	1,45	1,68	1,96	2,29	2,67	3,11	3,36	3,63	3,91	4,23	4,56	4,93	5,32	5,32
6 300	1,56	1,82	2,12	2,47	2,88	3,36	3,63	3,91	4,23	4,56	4,93	5,32	5,75	5,75
8 000	1,68	1,96	2,29	2,67	3,11	3,63	3,91	4,23	4,56	4,93	5,32	5,75	6,20	6,20
10 000	1,82	2,12	2,47	2,88	3,36	3,91	4,23	4,56	4,93	5,32	5,75	6,20	6,70	6,70
12 500	1,96	2,29	2,67	3,11	3,36	4,23	4,56	4,93	5,32	5,75	6,20	6,70	7,23	7,23
16 000	2,12	2,47	2,88	3,36	3,91	4,56	4,93	5,23	5,75	6,20	6,70	7,23	7,81	7,81
20 000	2,29	2,67	3,11	3,63	4,23	4,93	5,32	5,75	6,20	6,70	7,23	7,81	8,43	8,43
25 000	2,47	2,88	3,36	3,91	4,56	5,32	5,75	6,20	6,70	7,23	7,81	8,43	9,11	9,11
32 000	2,67	3,11	3,63	4,23	4,93	5,75	6,20	6,70	7,23	7,81	8,43	9,11	9,83	9,83
40 000	2,88	3,36	3,91	4,56	5,32	6,20	6,70	7,23	7,81	8,43	9,11	9,83	10,60	10,60
50 000	3,11	3,63	4,23	4,93	5,75	6,70	7,23	7,81	8,43	9,11	9,83	10,60	11,50	11,50
63 000	3,36	3,91	4,56	5,32	6,20	7,23	7,81	8,43	9,11	9,83	10,60	11,50	12,40	12,40
80 000	3,36	4,23	4,93	5,75	6,70	7,81	8,43	9,11	9,83	10,60	11,50	12,40	13,40	13,40
100 000	3,91	4,56	5,32	6,20	7,23	8,43	9,11	9,83	10,60	11,50	12,40	13,40	14,50	14,50
200 000	4,93	5,75	6,70	7,81	9,11	10,60	11,50	12,40	13,40	14,50	15,60	16,80	18,20	18,20

C/P ratio dependent on L_{10h} durability and rotation speed n for ball bearings

Rotation speed n [min ⁻¹]															
630	800	1 000	1 250	1 600	2 000	2 500	3 200	4 000	5 000	6 300	8 000	10 000	12 500	16 000	
1,56	1,68	1,82	1,96	2,12	2,29	2,47	2,67	2,88	3,11	3,36	3,63	3,91	4,23	4,56	
2,67	2,88	3,11	3,36	3,63	3,91	4,23	4,56	4,93	5,32	5,75	6,20	6,70	7,23	7,81	
3,36	3,63	3,91	4,23	4,56	4,93	5,32	5,75	6,20	6,70	7,23	7,81	8,43	9,11	9,83	
3,63	3,91	4,23	4,56	4,93	5,32	5,75	6,20	6,70	7,23	7,81	8,43	9,11	9,83	10,60	
3,91	4,23	4,56	4,93	5,32	5,75	6,20	6,70	7,23	7,81	8,43	9,11	9,83	10,60	11,50	
4,23	4,56	4,93	5,32	5,75	6,20	6,70	7,23	7,81	8,43	9,11	9,83	10,60	11,50	12,40	
4,56	4,93	5,32	5,75	6,20	6,70	7,23	7,81	8,43	9,11	9,83	10,60	11,50	12,40	13,40	
4,93	5,32	5,75	6,20	6,70	7,23	7,81	8,43	9,11	9,83	10,60	11,50	12,40	13,40	14,50	
5,32	5,75	6,20	6,70	7,23	7,81	8,43	9,11	9,83	10,60	11,50	12,40	13,40	14,50	15,60	
5,75	6,20	6,70	7,23	7,81	8,43	9,11	9,83	10,60	11,50	12,40	13,40	14,50	15,60	16,80	
6,20	6,70	7,23	7,81	8,43	9,11	9,83	10,60	11,50	12,40	13,40	14,50	15,60	16,80	18,20	
6,70	7,23	7,81	8,43	9,11	9,83	10,60	11,50	12,40	13,40	14,50	15,60	16,80	18,20	19,60	
7,23	7,81	8,43	9,11	9,83	10,60	11,50	12,40	13,40	14,50	15,60	16,80	18,20	19,60	21,20	
7,81	8,43	9,11	9,83	10,60	11,50	12,40	13,40	14,50	15,60	16,80	18,20	19,60	21,20	22,90	
8,43	9,11	9,83	10,60	11,50	12,40	13,40	14,50	15,60	16,80	18,20	19,60	21,20	22,90	24,70	
9,11	9,83	10,60	11,50	12,40	13,40	14,50	15,60	16,80	18,20	19,60	21,20	22,90	24,70	26,70	
9,83	10,60	11,50	12,40	13,40	14,50	15,60	16,80	18,20	19,60	21,20	22,90	24,70	26,70	28,80	
10,60	11,50	12,40	13,40	14,50	15,60	16,80	18,20	19,60	21,20	22,90	24,70	26,70	28,80	31,10	
11,50	12,40	13,40	14,50	15,60	16,80	18,20	19,60	21,20	22,90	24,70	26,70	28,80	31,10	-	
12,40	13,40	14,50	15,60	16,80	18,20	19,60	21,20	22,90	24,70	26,70	28,80	31,10	-	-	
13,40	14,50	15,60	16,80	18,20	19,60	21,20	22,90	24,70	26,70	28,80	31,10	-	-	-	
14,50	15,60	16,80	18,20	19,60	21,20	22,90	24,70	26,70	28,80	31,10	-	-	-	-	
15,60	16,80	18,20	19,60	21,20	22,90	24,70	26,70	28,80	31,10	-	-	-	-	-	
19,60	21,20	22,90	24,70	26,70	28,80	31,10	-	-	-	-	-	-	-	-	

Table 5.3

C/P ratio dependent on L_{10h} durability and rotation speed n for cylindrical roller, spherical-roller, and tapered-roller bearings													
L_{10h} Durability	Rotation speed n [min ⁻¹]												
Hod	10	16	25	40	63	100	125	160	200	250	320	400	500
100	-	-	-	-	-	-	-	-	1,05	1,10	1,21	1,30	1,39
500	-	-	-	1,05	1,21	1,39	1,49	1,60	1,71	1,83	1,97	2,11	2,26
1 000	-	-	1,13	1,30	1,49	1,71	1,83	1,97	2,11	2,26	2,42	2,59	2,78
1 250	-	1,05	1,21	1,39	1,60	1,83	1,97	2,11	2,26	2,42	2,59	52,78	2,97
1 600	-	1,13	1,30	1,49	1,71	1,97	2,11	2,26	2,42	2,59	2,78	2,97	3,19
2 000	1,05	1,21	1,39	1,60	1,83	2,11	2,26	2,42	2,59	2,78	2,97	3,19	3,42
2 500	1,13	1,30	1,49	1,71	1,97	2,26	2,42	2,59	2,78	2,97	3,19	3,42	3,66
3 200	1,21	1,39	1,60	1,83	2,11	2,42	2,59	2,78	2,97	3,19	3,42	3,66	3,92
4 000	1,30	1,49	1,71	1,97	2,26	2,59	2,78	2,97	3,19	3,42	3,66	3,92	4,20
5 000	1,39	1,60	1,83	2,11	2,42	2,78	2,97	3,19	3,42	3,66	3,92	4,20	4,50
6 300	1,49	1,71	1,97	2,26	2,59	2,97	3,19	3,42	3,66	3,92	4,20	4,50	4,82
8 000	1,60	1,83	2,11	2,42	2,78	3,19	3,42	3,66	3,92	4,20	4,50	4,82	5,17
10 000	1,71	1,97	2,26	2,59	2,97	3,42	3,66	3,92	4,20	4,50	4,82	5,17	5,54
12 500	1,83	2,11	2,42	2,78	3,19	3,66	3,92	4,20	4,50	4,82	5,17	5,54	5,94
16 000	1,97	2,26	2,59	2,97	3,42	3,92	4,20	4,50	4,82	5,17	5,54	5,94	6,36
20 000	2,11	2,42	2,78	3,19	3,66	4,20	4,50	4,82	5,17	5,54	5,94	6,36	6,81
25 000	2,26	2,59	2,97	3,42	3,92	4,50	4,82	5,17	5,54	5,94	6,36	6,81	7,30
32 000	2,42	2,78	3,19	3,66	4,20	4,82	5,17	5,54	5,94	6,36	6,81	7,30	7,82
40 000	2,59	2,97	3,42	3,92	4,50	5,17	5,54	5,94	6,36	6,81	7,30	7,82	8,38
50 000	2,78	3,19	3,66	4,20	4,82	5,54	5,94	6,36	6,81	7,30	7,82	8,38	8,98
63 000	2,97	3,42	3,92	4,50	5,17	5,94	6,36	6,81	7,30	7,82	8,38	8,98	9,62
80 000	3,19	3,66	4,20	4,82	5,54	6,36	6,81	7,30	7,82	8,38	8,98	9,62	10,30
100 000	3,42	3,92	4,50	5,17	5,94	6,81	7,30	7,82	8,38	8,98	9,62	10,30	11,00
200 000	4,20	4,82	5,54	6,36	7,30	8,38	8,98	9,62	10,30	11,00	11,80	12,70	13,60

C/P ratio dependent on L_{10h} durability and rotation speed n for cylindrical roller, spherical-roller, and tapered-roller bearings

Rotation speed n [min ⁻¹]															
630	800	1 000	1 250	1 600	2 000	2 500	3 200	4 000	5 000	6 300	8 000	10 000	12 500	16 000	
1,49	1,60	1,71	1,83	1,97	2,11	2,26	2,42	2,59	2,78	2,97	3,19	3,42	3,66	3,92	
2,42	2,59	2,78	2,97	3,19	3,42	3,66	3,92	4,20	4,50	4,82	5,70	5,54	5,94	6,36	
2,97	3,19	3,42	3,66	3,92	4,20	4,50	4,82	5,17	5,54	5,94	6,36	6,81	7,30	7,82	
3,19	3,42	3,66	3,92	4,20	4,50	4,82	5,17	5,54	5,94	6,36	6,81	7,30	7,82	8,38	
3,42	3,66	3,92	4,20	4,50	4,82	5,17	5,54	5,94	6,36	6,81	7,30	7,82	8,38	8,98	
3,66	3,92	4,20	4,50	4,82	5,17	5,54	5,94	6,36	6,81	7,30	7,82	8,38	8,98	9,62	
3,92	4,20	4,50	4,82	5,17	5,54	5,94	6,36	6,81	7,30	7,82	8,38	8,98	9,62	10,30	
4,20	4,50	4,82	5,17	5,54	5,94	6,36	6,81	7,30	7,82	8,38	8,98	9,62	10,30	11,00	
4,50	4,82	5,17	5,54	5,94	6,36	6,81	7,30	7,82	8,38	8,98	9,62	10,30	11,00	11,80	
4,82	5,17	5,54	5,94	6,36	6,81	7,30	7,82	8,38	8,98	9,62	10,30	11,00	11,80	12,70	
5,17	5,54	5,94	6,36	6,81	7,30	7,82	8,38	8,98	9,62	10,30	11,00	11,80	12,70	13,60	
5,54	5,94	6,36	6,81	7,30	7,82	8,38	8,98	9,62	10,30	11,00	11,80	12,70	13,60	14,60	
5,94	6,36	6,81	7,30	7,82	8,38	8,98	9,62	10,30	11,00	11,80	12,70	13,60	14,60	15,60	
6,36	6,81	7,30	7,82	8,38	8,98	9,62	10,30	11,00	11,80	12,70	13,60	14,60	15,60	16,70	
6,81	7,30	7,82	8,38	8,98	9,62	10,30	11,00	11,80	12,70	13,60	14,60	15,60	16,70	17,90	
7,30	7,82	8,38	8,98	9,62	10,30	11,00	11,80	12,70	13,60	14,60	15,60	16,70	17,90	19,20	
7,82	8,38	8,98	9,62	10,30	11,00	11,80	12,70	13,60	14,60	15,60	16,70	17,90	19,20	20,60	
8,38	8,98	9,62	10,30	11,00	11,80	12,70	13,60	14,60	15,60	16,70	17,90	19,20	20,60	-	-
8,98	9,62	10,30	11,00	11,80	12,70	13,60	14,60	15,60	16,70	17,90	19,20	20,60	-	-	-
9,62	10,30	11,00	11,80	12,70	13,60	14,60	15,60	16,70	17,90	19,20	20,60	-	-	-	-
10,30	11,00	11,80	12,70	13,60	14,60	15,60	16,70	17,90	19,20	20,60	-	-	-	-	-
11,00	11,80	12,70	13,60	14,60	15,60	16,70	17,90	19,20	20,60	-	-	-	-	-	-
11,80	12,70	13,60	14,60	15,60	16,70	17,90	19,20	20,60	-	-	-	-	-	-	-
14,60	15,60	16,70	17,90	19,20	20,60	-	-	-	-	-	-	-	-	-	-

Table 5.4

Standard basic durability values in operating hours	
Type of machine	Basic durability L_{10h}
Seldom used machines and tools	1 000
Electrical household appliances, small fans	2 000 to 4 000
tools for intermittent use, hand tools, workshop cranes, agricultural machines	4 000 to 8 000
machines for intermittent use with high reliability demands, auxiliary machines for use in power plants, belt conveyors, transport trolleys, elevators	8 000 to 15 000
rolling mills	6 000 to 12 000
machines for 8-16 hour shifts, stationary motors, gears, spindles for textile machines, plastic processing machinery, printing machinery, cranes	15 000 to 30 000
machine tools, in general	20 000 to 30 000
machines for continuous operation: stationary electrical machines, transportation equipment, roller conveyors, pumps, centrifuges, blowers, compressors, hammer mills, shredders, briquetting presses, mine hoists, cable reels	40 000 to 60 000
machines for continuous operation with high operating safety requirements: power plant machinery, waterworks machines, paper mill machinery, ship machinery	100 000 to 200 000

Table 5.5

Standard values of basic durability in kilometres	
Type of vehicle	Basic durability L_{10km}
Road vehicle wheel bearings	
motorcycles	60 000
personal automobiles	150 000 to 250 000
lorries, buses	400 000 to 500 000
Axle bearings of rail vehicles	
freight cars (according to UIC) under constant maximal load per axle	800 000
trams	1 500 000
personal rail vehicles	3 000 000
motorized vehicles and motorized units	3 000 000 to 4 000 000
locomotives	3 000 000 to 5 000 000

5.6 Modified durability equation

The operating durability, as previously described, depends on many factors. Research and operating results demonstrated that greater durability can be achieved through thorough lubrication, when the roller elements are entirely separated by a layer of grease. It was further demonstrated that greater resistance against stress damage of materials is provided using advanced manufacturing processes. This technical advance was incorporated into standard ISO 281 as a modified durability calculation, which includes reliability a_1 , material a_2 , and operating condition a_3 factors. Additional test results concluded that the impact of materials on operating conditions, in particular, lubrication, are in close correlation. This led to the merger of both factors into one a_{23} .

The modified durability is thus the modified basic durability which, aside from taking into account load, also considers the impact of bearing material components, the physical and chemical properties of the lubricant, and the temperature regime of the bearing operating environment.

$$L_{na} = a_1 \cdot a_{23} \cdot L_{10}$$

L_{na} modified durability for reliability $(100 - n)$ %
and other than normal operating conditions [10⁶ rev]

a_1 reliability coefficient for other than 90 % reliability, see table 5.6

a_{23} material, lubricant, manufacturing technology, and operating condition coefficient, see fig. 5.3

L_{10} basic durability [10⁶ rev]

Table 5.6

Coefficient a_1 values		
Reliability (%)	L_n	a_1
90	L_{10}	1,000
95	L_5	0,640
96	L_4	0,550
97	L_3	0,470
98	L_2	0,370
99	L_1	0,250
99,2	$L_{0,8}$	0,220
99,4	$L_{0,6}$	0,190
99,6	$L_{0,4}$	0,160
99,8	$L_{0,2}$	0,120
99,9	$L_{0,1}$	0,093
99,92	$L_{0,08}$	0,087
99,94	$L_{0,06}$	0,080
99,95	$L_{0,05}$	0,077

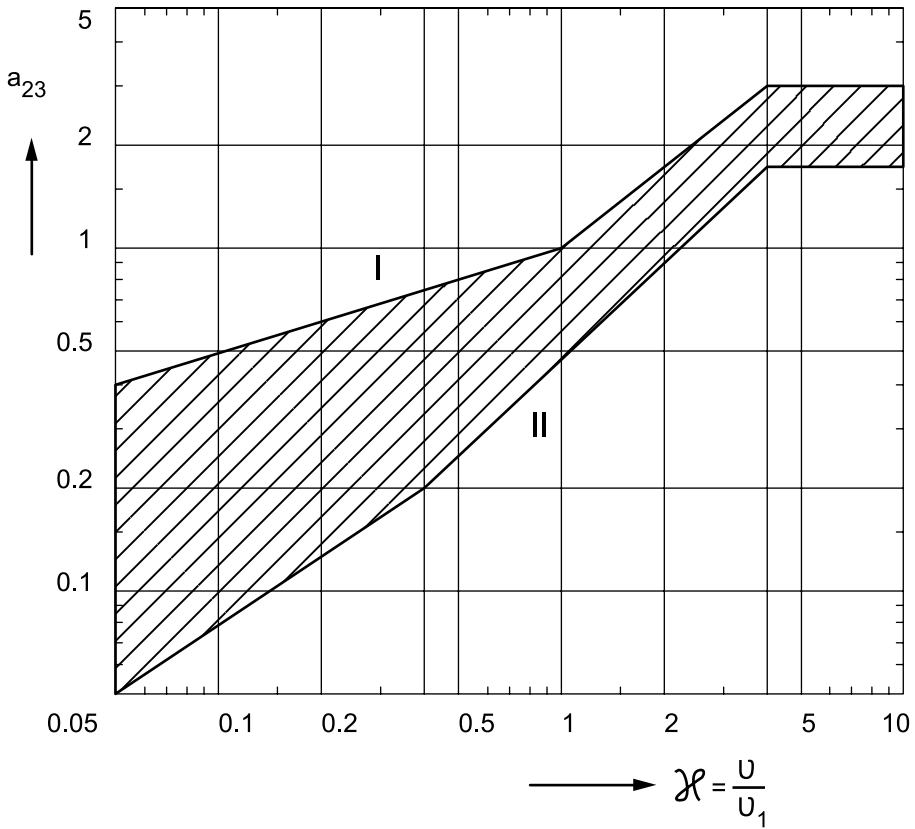

Fig. 5.3

The diagram in fig. 5.4 is used to determine the basic values of coefficient a_{23} .

The quality of the lubrication process is given by the extent of separation of the roller surfaces. Viscosity is a decisive factor for the formation of lubricant film, which is strongly related to temperature. The viscosity ratio, as follows, decides on the use of lubricant:

$$\kappa = \frac{\nu}{\nu_1}$$

ν lubricant kinematic viscosity at bearing operating temperature [mm² · s⁻¹]

ν_1 kinematic viscosity for the defined revolution speed
and the given dimension of the bearing [mm² · s⁻¹]

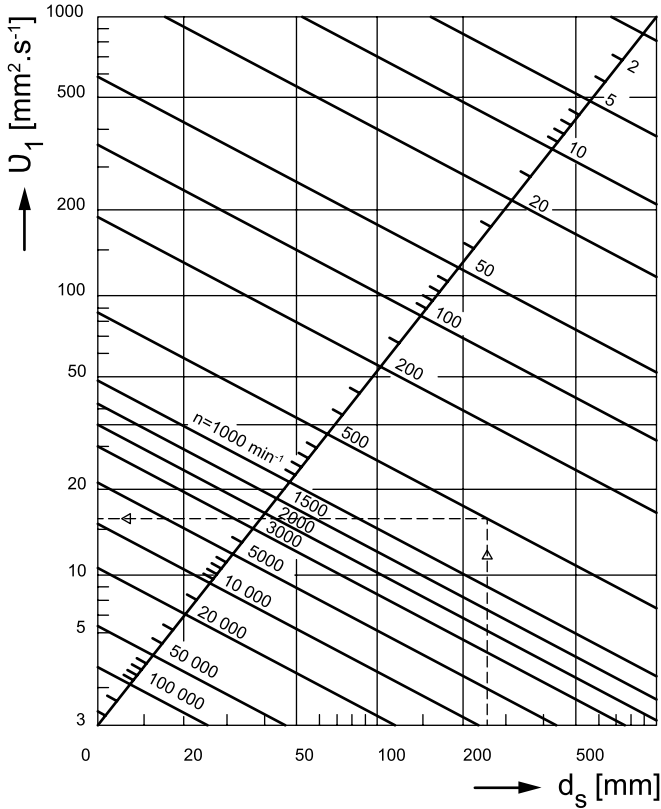

Fig. 5.4

We determine the ν and ν_1 values based on the diagram found in fig. 5.4 and 5.5. In the diagram on fig. 5.3, line I applies for radial ball bearings that operate in a very clean environment. In all other cases, we select a lower a_{23} coefficient, proportional to the cleanliness of the environment, while a decreasing tendency is dependent on the structural group of the bearing in the following order:

- Angular-contact ball bearings
- Tapered-roller bearings
- Cylindrical roller bearings
- Double-row self-aligning bearings
- Spherical-roller bearings

Line II can be used to determine coefficient a_{23} for spherical-roller bearings that operate in a dusty environment.

We recommend that these issues be resolved in consultation with the ZKL technical and consultation services department.

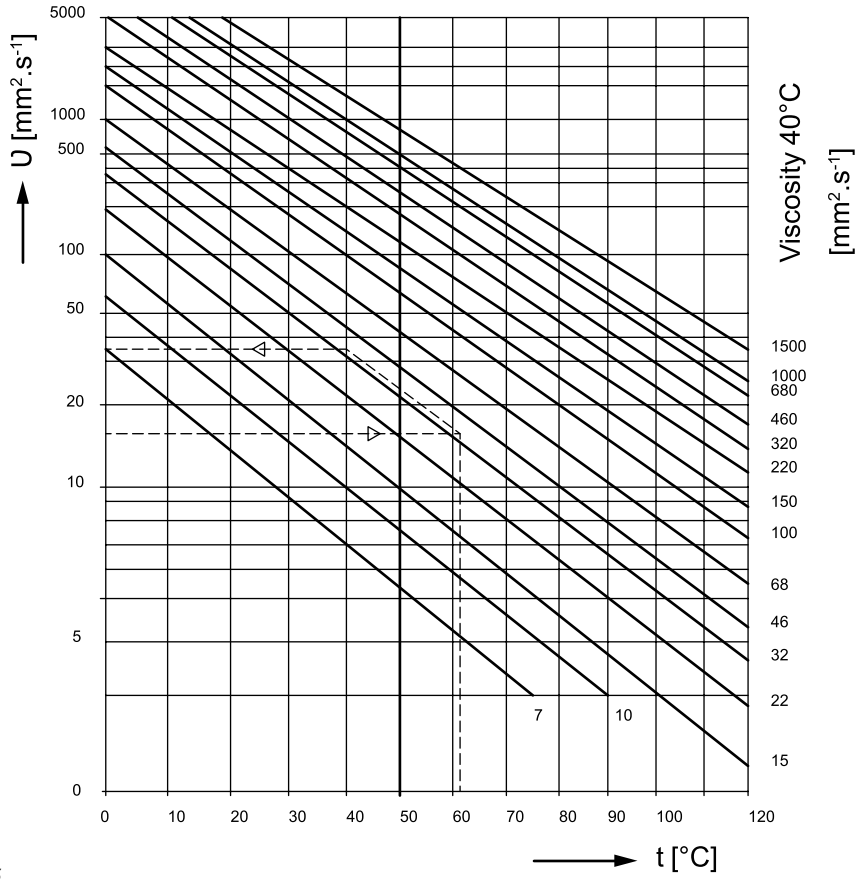

Fig. 5.5

5.7 Durability according ZKL

The use of the L_{10} calculation of basic durability as bearing performance parameter criteria has demonstrated, over many years, to be satisfactory. This calculation is associated with 90 % reliability in conjunction with the use of superior materials, a superior technological design, and under normal operating conditions.

Notwithstanding, many applications require that the calculation be performed for a different reliability level or for more precise lubrication and contamination conditions. It was determined, with the use of advanced high quality bearing steel, that under favourable operating conditions and when contact stresses fall below the limit values and provided that the bearing steel fatigue stress limit is not exceeded, a higher durability than L_{10} can be achieved. Under unfavourable operating conditions, on the other hand, the bearing durability can in fact be shorter than L_{10} .

A system approach of fatigue-related durability was applied when creating the method of calculating ZKL modified durability. The impact on the durability of the system (bearing) is described in the following text and considers the influence of variance and the interaction of mutually related factors on the overall life. These factors are demonstrated through increased contact stress in the contact area, which leads to decreased service life.

These factors are used in the modified durability equation.

$$L_m = a_1 \cdot a_{ZKL} \cdot L_{10}$$

a_1 reliability coefficient for other than 90% reliability, see table 5.6

a_{ZKL} modified life coefficient

L_{10} basic durability [10⁶ rev]

Provided that the lubrication conditions, cleanliness of the environment, and other operation conditions are favourable, an advanced, high-quality bearing can, under a certain load, achieve infinite service life. The fatigue load limit for bearings manufactured from generally high-quality bearing material and workmanship is such a load, that the contact pressure exerted on roller elements in the bearing is approximately 1500 MPa. This stress value takes into account the additional stresses caused by manufacturing tolerances and operating conditions. Decreased product precision and quality of materials leads to a lower fatigue load limit.

The contact stress in many applications is greater than 1500 MPa. Such operating conditions lead to reduced bearing life.

The operating influences can be related to the applied stress and rigidity of the material.

- Notches lead to the formation of edge stresses.
- A thin film of oil increases the stress at the contact area between the raceway and the roller element.
- Increased temperature decreases the fatigue load limit (its strength) of the material.
- A static inner ring (increased overlap) leads to increased orbital stress

Various influences on bearing durability are mutually dependant. Consequently, a systemic approach to calculating fatigue durability is entirely appropriate.

A theoretical explanation of how to incorporate additional influences, such as the radial clearance during operation and the variable stress on raceways from tilting, is explained in ISO/TS 16281.

5.7.1 Fatigue load limit

The modified durability coefficient a_{zkl} can be expressed as function

$$\frac{\sigma_u}{\sigma}$$

(fatigue load limit divided by the real stress σ , while considering all potential influencing factors).

If the actual stress decreases to fatigue stress limit, then a_{zkl} asymptotically approaches infinity. Generally, the orthogonal shear stress is used as a fatigue criterion. The diagram on fig. 5.6 is also based on the shear fatigue limit.

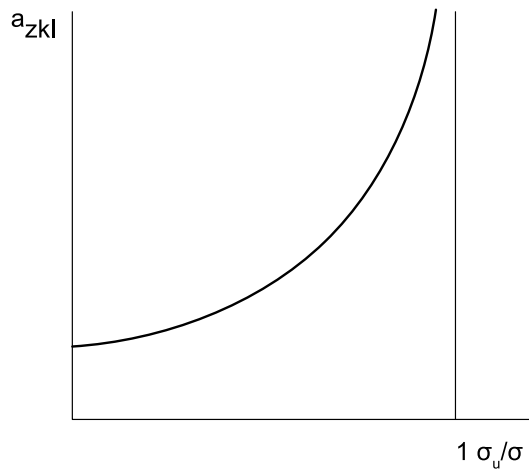

Fig. 5.6

Analogous to the C_{or} static load rating, defined in ISO 76, the fatigue load limit is defined as the load, during which the stress fatigue limit is reached at the most burdened point on the orbit.

The ratio $\frac{\sigma_u}{\sigma}$ can then be estimated according to the ratio $\frac{C_{or}}{P}$

and the modified life coefficient can be expressed as:

$$a_{zkl} = f \left[\frac{C_{or}}{P} \right]$$

The following must be considered when calculating the C_{or} static load rating:

- The type, size, and internal geometry of the bearing
- The profile of rolling elements and the raceways
- The quality of technological processes
- The fatigue limit for the raceway materials

5.7.2 Determining the modified durability coefficient

The modified durability coefficient takes into consideration the following:

- The fatigue load and bearing load
- Lubrication (type of lubricant, viscosity, revolution speed, bearing size, additives)
- Environment (degree of contamination, packing)
- Contaminating particles (strength and size of particles in relation to bearing size, lubrication and filtration method)
- Installation (cleanliness during installation)

The effect of bearing clearance and the effect of tilt on bearing durability is described in ISO/TS 16281.

The a_{ZKL} Fatigue life coefficient is derived from the following equation:

$$a_{ZKL} = f \left[\frac{e_c \cdot C_{or}}{P}, \kappa \right]$$

Factors e_c and κ adjust for contamination and lubrication conditions.

5.7.3 Contamination factor

If the grease is contaminated with solid particles, notches may form in the orbit due to rolling. Stress points (concentrations) form later on these notches, which results in decreased bearing life. The given decrease in life caused by the contamination of lubricant is adjusted for in the e_c contamination factor.

Decreased bearing life caused by the effect of solid particles in the lubricant film depends on:

- The type, size, strength, and amount of particles
- The lubricating film thickness (relative viscosity)
- Bearing size

Approximate contamination factor values can be taken from table 5.7.

Table 5.7

Contamination level	e_c	
	$D_{pw} < 100 \text{ mm}$	$D_{pw} \geq 100 \text{ mm}$
Extremely clean Particle size in the order of lubricating film thickness, Laboratory conditions	1	1
Highly clean Oil filtered through a very fine filter, typical conditions for a bearing with plastic housing and lifetime lubricant filling	0,8 to 0,6	0,9 to 0,8
Normally clean Oil filtered through a fine filter, typical conditions for a bearing with metal-sheet housing and lifetime lubricant filling	0,6 to 0,5	0,8 to 0,6
Mild contamination Minor contamination in lubricant	0,5 to 0,3	0,6 to 0,4
Typical contamination Typical bearing conditions without integrated bearing glands, particles causing wear enter bearing from vicinity	0,3 to 0,1	0,4 to 0,2
Strong contamination The bearing environment is strongly contaminated, bearing housing with insufficient bearing glands	0,1 to 0	0,1 to 0
Very strong contamination	0	0

Detailed calculation of the contamination factor

Table 5.7 lists the approximate contamination factor values. If the situation requires the use of more detailed calculations, the more precise calculation, provided below, must be used.

A contamination factor may be established for the following types of lubricants:

- Circulating oil lubrication with on-line filtration
- Oil bath lubrication or circulating lubrication with off-line filtration
- Grease

Definition of the β_x filtration ratio:

$$\beta_x = \frac{n_1}{n_2}$$

β_x filtration ratio for particles of determined size x

n_1 number of particles per unit of volume (100 ml) larger than x , prior to passage through filter

n_2 number of particles per unit of volume (100 ml) larger than x , after passage through filter

The filter ratio determined the filter efficiency.

Circulating lubrication with on-line filtration

The β_x filter ratio with particles of size x in μm according to standard ISO 16889 is the most influential factor when choosing the corresponding diagram.

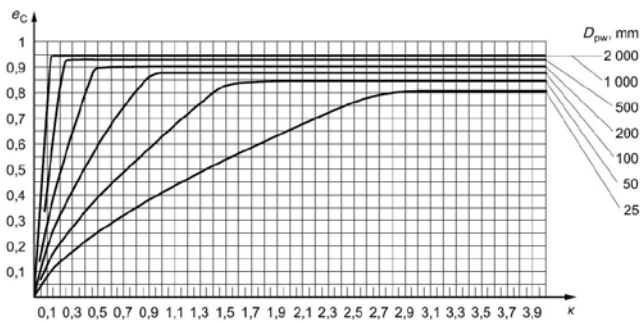

Fig. 5.7 Fouling factor for a circulating oil lubrication system with on-line filtration $\beta_6 = 200$

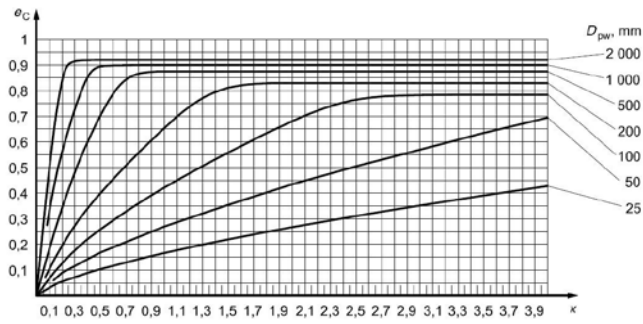

Fig. 5.8 Fouling factor for a circulating oil lubrication system with on-line filtration $\beta_{12} = 200$

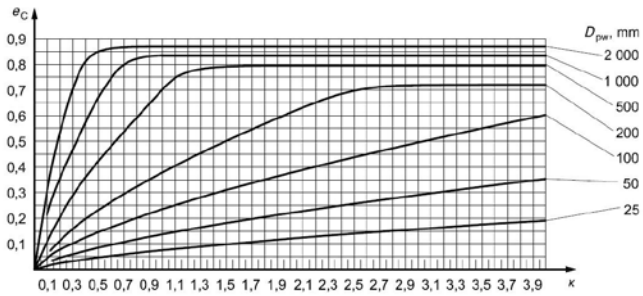

Fig. 5.9 Fouling factor for a circulating oil lubrication system with on-line filtration $\beta_{25} = 75$

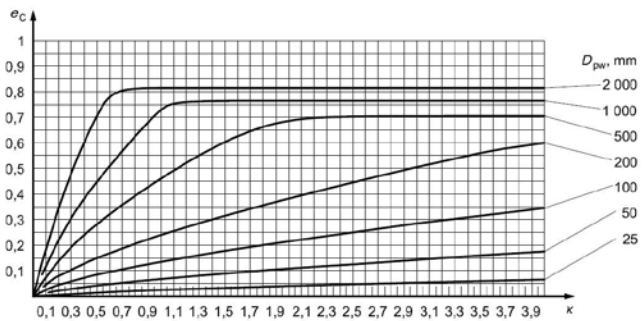

Fig. 5.10 Fouling factor for a circulating oil lubrication system with on-line filtration $\beta_{40} = 75$

Oil bath lubrication or circulating lubrication with off-line filtration

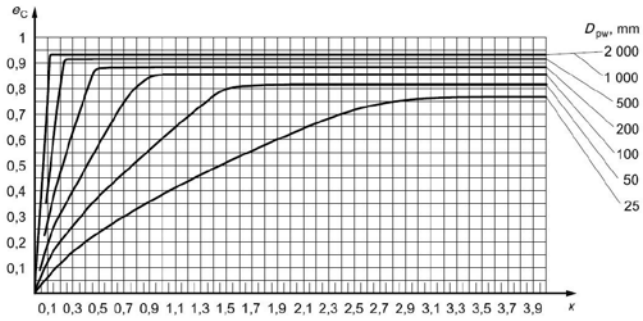

Fig. 5.11 Fouling factor for oil bath lubrication or for oil lubrication with offline filtration
ISO 4406 – degree of contamination by solid particles -13/10

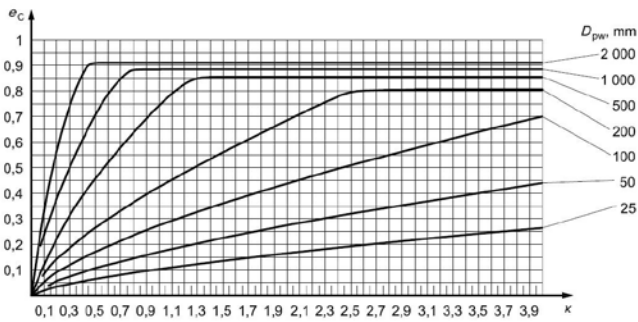

Fig. 5.12 Fouling factor for oil bath lubrication or for oil lubrication with offline filtration
ISO 4406 – degree of contamination by solid particles -15/12

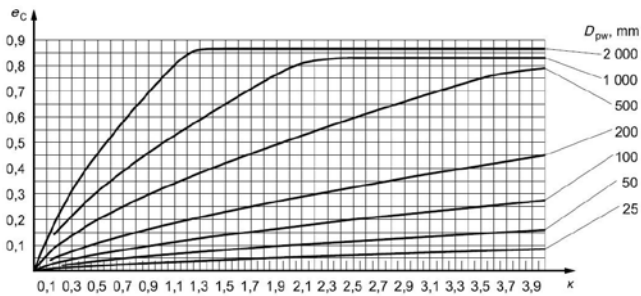

Fig. 5.13 Fouling factor for oil bath lubrication or for oil lubrication with offline filtration
ISO 4406 – degree of contamination by solid particles -17/14

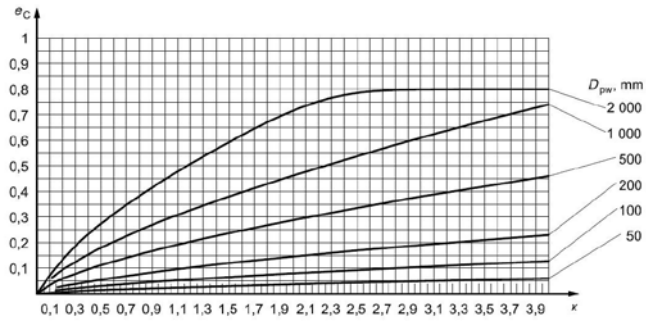

Fig. 5.14 Fouling factor for oil bath lubrication or for oil lubrication with offline filtration
ISO 4406 – degree of contamination by solid particles -19/16

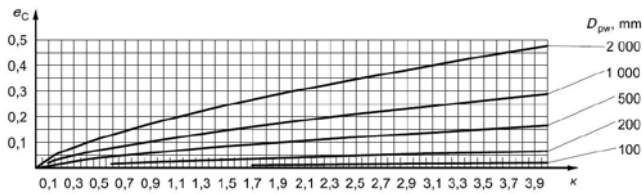

Fig. 5.15 Fouling factor for oil bath lubrication or for oil lubrication with offline filtration
ISO 4406 – degree of contamination by solid particles -21/18

Grease

Table 5.8

Operating conditions	Contamination level
Very clean installation, very good packing relative to operating conditions, continuous lubrication or lubrication in short intervals (Bearings with integrated bearing glands)	Highly clean
Clean installation, good packing, additional lubrication per manufacturer specifications (Bearings with integrated bearing glands)	Normally clean
Clean installation, average sealing capacity relative to operating conditions	Mild contamination
On-site-installation, bearing and housing insufficiently washed following installation, poor sealing capacity relative to operating conditions, re-lubrication intervals longer than recommended	Strong contamination
Installation in a contaminated environment, insufficient gland packaging, long re-lubrication intervals	Very strong contamination

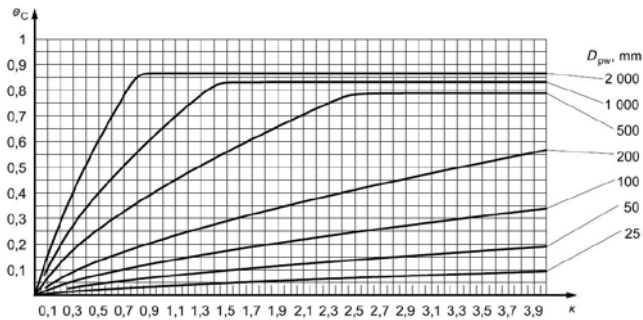

Fig. 5.16 Fouling factor for grease lubrication – moderate pollution

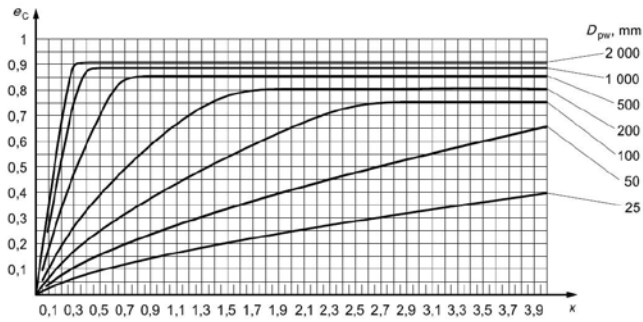

Fig. 5.17 Fouling factor for grease lubrication – usual purity

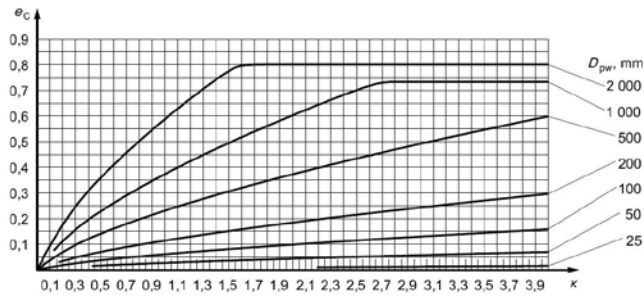

Fig. 5.18 Fouling factor for grease lubrication - strong contamination

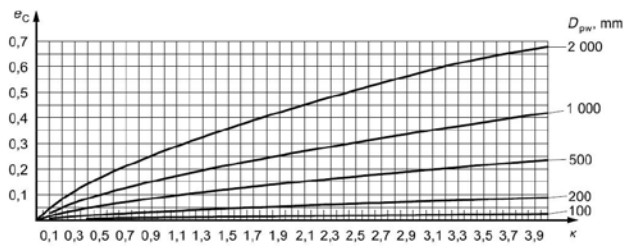

Fig. 5.19 Fouling factor for grease lubrication – very strong contamination

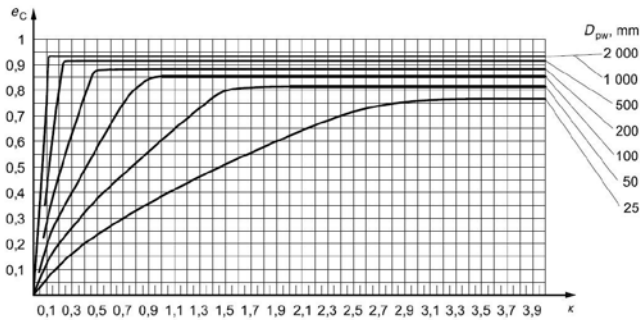

Fig. 5.20 Fouling factor for grease lubrication – high purity

5.7.4 Viscosity ratio

The effectiveness of the lubricant is primarily given by the degree of separation of contact elements. The formation of adequate lubricating film is subject to the given minimal viscosity that the lubricant must possess, when the application achieves its operating temperature. A requirement for the formation of lubricating film is specified by the viscosity ratio κ , which is defined as the ratio between the real (actual) kinematic viscosity ν and the reference kinematic viscosity ν_1 . The kinematic viscosity ν is the viscosity of the lubricant, when the given lubricant achieves its operating temperature.

$$\kappa = \frac{\nu}{\nu_1}$$

In order to create sufficient lubricating film, the lubricant must maintain a certain minimal viscosity at operating temperature. The bearing life may be increased by increasing the operating viscosity ν .

The reference kinematic viscosity can be determined from figure 5.4 or by using the following equations:

$$\nu_1 = 45\,000 \cdot n^{-0.8} \cdot D_{pw}^{-0.5} \quad \text{for } n < 1\,000 \text{ min}^{-1}$$

$$\nu_1 = 45\,000 \cdot n^{-0.5} \cdot D_{pw}^{-0.5} \quad \text{for } n \geq 1\,000 \text{ min}^{-1}$$

$$D_{pw} = 0.5 \cdot (d + D) \text{ is the bearing mean diameter}$$

5.7.5 Calculating the modified durability coefficient

The modified durability coefficient a_{ZKL} may be easily determined from the following graphs:

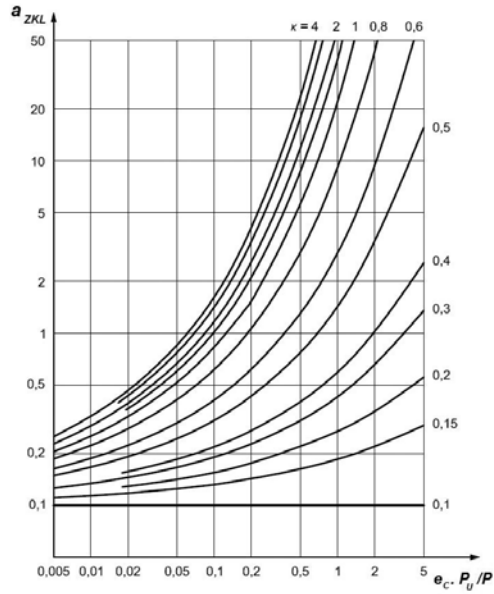

Fig. 5.21 Coefficient of life modification factor for thrust ball bearings

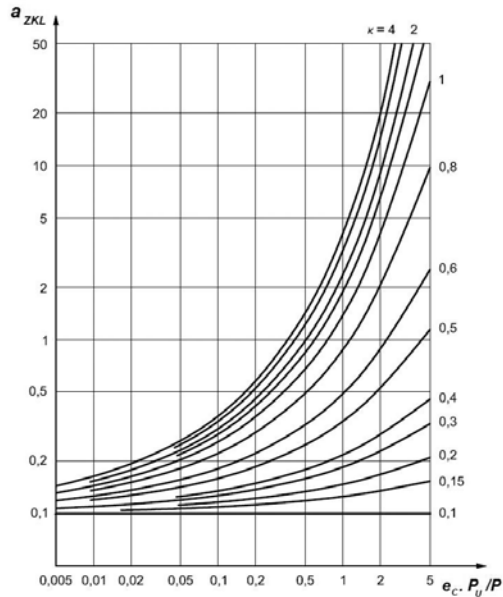

Fig. 5.22 Coefficient of life modification factor for thrust rolling bearings

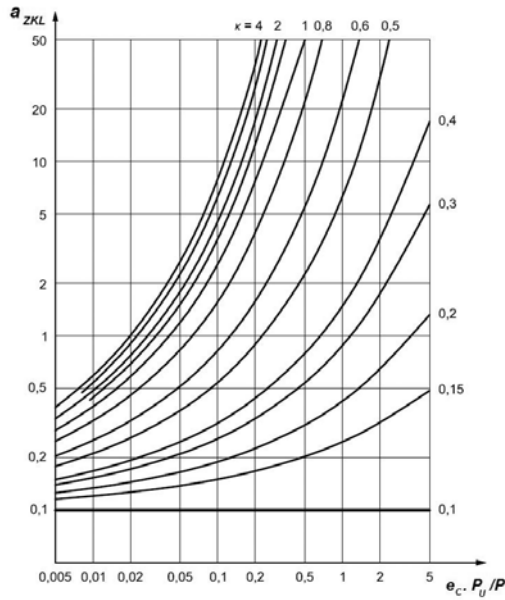

Fig. 5.23 Coefficient of life modification factor for radial ball bearings

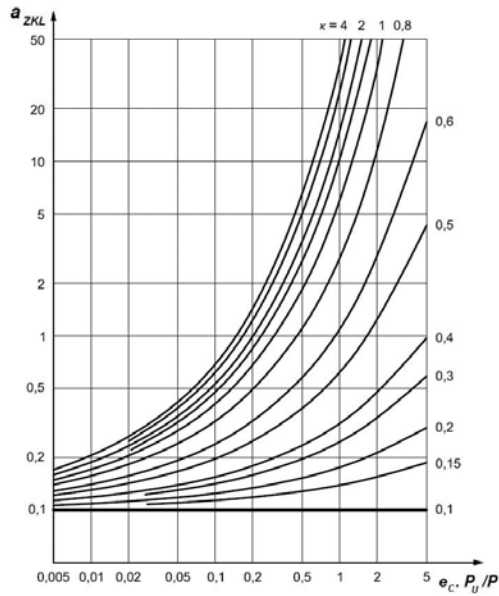

Fig. 5.24 Coefficient of life modification factor for radial rolling bearing

5.8 Equivalent dynamic load

The bearing in the structural node is exposed generally to acting forces of various magnitudes at various revolution speeds and with various periods of action. In terms of the calculation method, the applied forces must be recalculated at constant load, during which the bearing has the same durability as achieved under actual load. This recalculated constant radial or axial load is called equivalent load P , or P_r [radial] or P_a [axial], resp.

5.8.1 Combined loads

Constant load method

The external forces applied on the bearing do not change in size or in relation to time.

Radial bearings

If constant radial or axial forces simultaneously act on a radial bearing, the following equation for calculating the radial dynamic load applies:

$$P_r = X \cdot F_r + Y \cdot F_a \quad [\text{kN}]$$

P_r radial equivalent dynamic load [kN]

F_r radial force acting on the bearing [kN]

F_a axial force acting on the bearing [kN]

X radial load coefficient

Y axial load coefficient

Coefficients X and Y are dependent on the ratio F_a / F_r . The values X and Y are provided in the table or in the commentary preceding each structural group, where further information is provided for bearing calculations of the respective structural group.

Thrust bearings

Thrust ball bearings can only transfer forces acting axially and the following equation applied for calculating the axial equivalent dynamic load:

$$P_a = F_a \quad [\text{kN}]$$

P_a axial equivalent dynamic load [kN]

F_a axial bearing load [kN]

Spherical-roller thrust bearings can also transfer certain radial loads, however, only when a simultaneous axial load is applied, while observing the following condition:

$$P_a = F_a + 1.2 \cdot F_r \quad [\text{kN}]$$

Variable loading method

A real variable load, whose time course is known, is replaced by a mean intended load to enable calculation. This intended load has the same effect on the bearing as an actual variable load.

5.8.2 Change in load magnitude at constant revolution speed

If a load acts on a bearing in a constant direction, whose size changes in relation to time, while the revolution speed is constant (fig. 5.25), we calculate the mean intended load F_s according to the equation

$$F_s = \sum_{i=1}^n F_i^3 \cdot \left(\frac{q_i}{100} \right)^{\frac{1}{3}} \quad [\text{kN}]$$

F_s intended mean constant load [kN]

$F_i = F_1, \dots, F_n$. . constant partial actual load [kN]

$q_i = q_1, \dots, q_n$. . . proportion of partially acting loads [%]

If a variable load acts on a bearing, while the rotation speed meanwhile changes (fig. 5.26), we calculate the mean intended load using the equation

$$F_s = \frac{F_{\min} + 2 \cdot F_{\max}}{3} \quad [\text{kN}]$$

Provided that the actual load has a sinusoid shape (fig. 5.27), the mean intended load is given by

$$F_s = 0.75 \cdot F_{\max} \quad [\text{kN}]$$

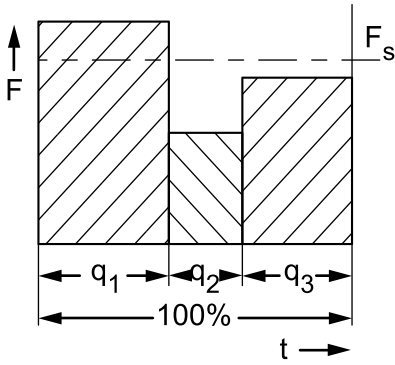

Fig. 5.25

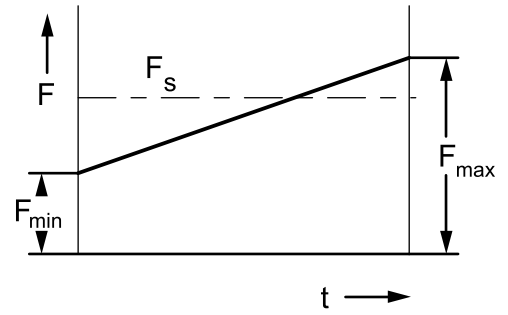

Fig. 5.26

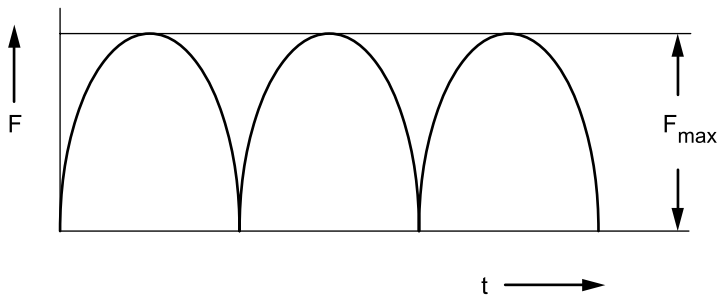

Fig. 5.27

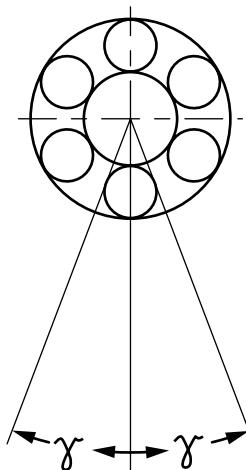

Fig. 5.28

5.8.3 Change in load magnitude when rotation speed changes

If a variable load acts on a bearing along with variable rotation speed, the intended mean load is derived from the equation

$$F_s = \left(\frac{\sum_{i=1}^n F_i^3 \cdot q_i \cdot n_i}{\sum_{i=1}^n q_i \cdot n_i} \right)^{\frac{1}{3}} \quad [\text{kN}]$$

$n_i = n_1, \dots, n_n \dots$ constant rotation speed during action of partial loads F_1, \dots, F_n [min^{-1}]

$q_i = q_1, \dots, q_n \dots$ proportion of partially acting loads and frequencies [%]

If the rotation speed only changes in relation to time, the intended mean rotation speed is calculated using the equation

$$n_s = \left(\frac{\sum_{i=1}^n q_i \cdot n_i}{100} \right) \quad [\text{min}^{-1}]$$

$n_s \dots \dots \dots$ mean rotation speed [min^{-1}]

5.8.4 Oscillating motion of the bearing

During oscillating motion with oscillating amplitude γ (fig. 5.28), it is easiest to substitute the oscillating motion by the notion of rotation, provided that the frequency of rotation is equal to the oscillating frequency. For radial bearings, we calculate the mean intended load using the equation

$$F_s = F_r \cdot \left(\frac{\gamma}{90} \right)^{\frac{1}{p}} \quad [\text{kN}]$$

$F_s \dots \dots \dots$ mean intended load [kN]

$F_r \dots \dots \dots$ actual radial load [kN]

$\gamma \dots \dots \dots$ amplitude of oscillation [$^\circ$]

$p \dots \dots \dots$ ball bearing exponent $p = 3$

For roller, needle roller, spherical-roller, and tapered-roller bearings $p = \frac{10}{3}$

5.9 Effect of temperature

The supplied range of bearings is designated for use in environments with a temperature of up to 120°C. Larger spherical roller bearings are manufactured, by default, for operation in temperatures up to 200°C. The exception are particular double row spherical roller bearings with polyamide races and single row ball bearings equipped with seals (RS, 2RS, RSR, 2RSR), which may be used short-term in temperatures up to 150°C. More information about these bearings is available in chapter 12 "Manufacturer data".

Rolling bearings designed for higher operating temperatures are manufactured to ensure their required physical and mechanical properties and dimensional stability. Housing solutions at higher operating temperatures should be consulted with the supplier.

The and dynamic load rating values C_r and C_a provided within the tables of the publication must, in the case of higher operating temperatures, be multiplied by the coefficient f_t , as specified in table 5.9.

Table 5.9

f _t Coefficient values				
operating temperature up to [°C]	150	200	250	300
f _t coefficient	0,95	0,9	0,75	0,6

5.10 Static Load Rating

The radial static load rating C_{or} and axial static load rating C_{oa} for each bearing is specified in the table section of the publication. The values C_{or} and C_{oa} were determined by calculation according to international standard ISO 76.

The static load rating is the load that corresponds to the calculated contact stress in the roller element and raceway contact zone, under the greatest load.

- 4600 MPa for double row self-aligning ball bearings
- 4200 MPa for other ball bearings
- 4000 MPa For roller, needle roller, spherical roller, and tapered roller bearings

This stress permanently deforms the rolling elements and raceways by approximately 0.0001 the diameter of the rolling element. The load is purely radial for radial bearings and purely axial within the bearing axis for thrust bearings.

The static load rating C_{or} is used for calculations, if the bearings

- rotate at very low speeds ($n < 10 \text{ min}^{-1}$)
- perform very slow oscillating motions
- under load do not move for a particular, extended period.

It is equally very important to check the safety in short-acting loads, such as e.g. shock loads and peak loads that act on a rotating bearing (dynamic load) or on a stationary bearing.

The maximum load that can act on a bearing should be used when calculating the equivalent static load of a bearing.

5.10.1 Equivalent static load

The equivalent static load is the recalculated radial load P_{or} for radial bearings and the axial load P_{oa} for thrust bearings.

$$P_{or} = X_0 \cdot F_r + Y_0 \cdot F_a \quad [\text{kN}]$$

$$P_{oa} = Y_0 \cdot F_a \quad [\text{kN}]$$

P_{or} radial equivalent static load [kN]

P_{oa} axial equivalent static load [kN]

F_r radial load [kN]

F_a axial load [kN]

X_0 radial load coefficient

Y_0 axial load coefficient

Table 5.10

s_0 Coefficient			
Bearing motion	Load bearing method, bearing operation requirements	s_0	
		Ball bearings	Cylindrical roller, needle-roller, spherical-roller, and tapered-roller bearings
rotational	significant impact loads, high demands on quite operation	2	4
	after static loading, bearing turns at lower loads	1,5	3
	normal demands for quiet operation		
	normal operating conditions and normal operating requirements	1	1,5
	quiet operation without vibration(s)	0,5	1
Oscillating	small oscillating angle with large frequency with occasional uneven loads	2	3,5
	large oscillating angle with small frequency with relatively constant periodical loads	1,5	2,5
non-rotating (at rest)	considerable impact loads	1,5 to 1	3 to 2
	normal and low loads, bearing operation unburdened by increased demands	1 to 0,4	2 to 0,8
	spherical-roller thrust bearings during all types of motion and loading	-	4

Coefficients X_0 and Y_0 are specified in the table section of the publication. Detailed information is also provided here for determining the equivalent static load of bearings of a particular structural group.

5.10.2 Bearing safety during static loading

In practice, the bearing safety under static load is determined from the ratio C_{or}/P_{or} or C_{oa}/P_{oa} and compared with the data in table 5.10, where the smallest permissible coefficient values S_0 are specified for various operating conditions.

$$S_0 = \frac{C_{or}}{P_{or}} \quad \text{and/or} \quad \frac{C_{oa}}{P_{oa}}$$

S_0 safety coefficient under static load [kN]

C_{or} radial dynamic load capacity [kN]

C_{oa} axial dynamic load capacity [kN]

P_{or} radial equivalent static load or max. acting force F_{max} (fig. 5.29) under significant impact load, resp. [kN]

P_{oa} axial equivalent static load or max. acting force F_{max} (fig. 5.29) under significant impact load, resp. [kN]

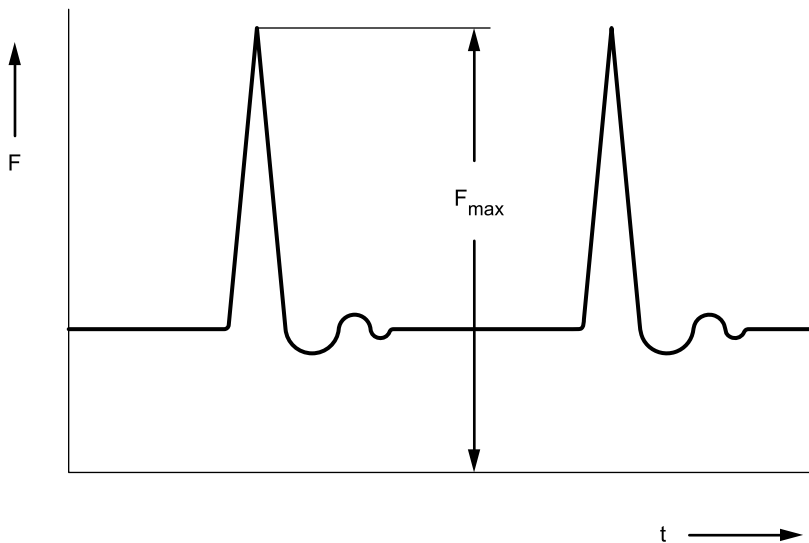

Fig. 5.29

6. CRITICAL SPEED AND VIBRATIONS

The operating speeds at which bearings can operate are limited by the operating temperature of the lubricant used or by the material of individual bearing components, resp.

The critical operating temperature then depends on the head induced by friction in the bearing and the amount of heat that can be dissipated from the bearing.

6.1 Bearing friction

The friction in the bearing depends on the load, the operating speed, the lubricant, and bearing type and size. Friction then significantly affects the generation of heat in the bearing and hence its operating temperature.

The total rolling resistance in the bearing is given by the sum of:

- the rolling and sliding friction at all contact points (rolling contact, contact between rolling elements and cage or guiding surfaces, resp.)
- friction in the lubricant
- the sliding friction of the friction seal, as applicable

6.1.1 Torque friction estimate

The friction torque can be determined, e.g. using the following relationship:

$$M = 0.5 \cdot \mu \cdot P \cdot d$$

M bearing friction torque [N·mm]

μ constant bearing friction coefficient (see table 6.1) [-]

P equivalent dynamic bearing load [N]

d bearing bore diameter [mm]

The given relationship applies with sufficient accuracy assuming proper lubrication, normal operating conditions and bearing load $P = 0.1 \cdot C$.

6.1.2 Calculating frictional torque

Total frictional torque M [N·mm] consists of hydrodynamic frictional torque M_0 [N·mm] of an unloaded bearing, which arises when rotating parts wade in a viscous environment and from rolling friction torque M_1 [N·mm]:

$$M = M_0 + M_1$$

Table 6.1

Bearing type	Coefficient of friction μ
Ball bearings	0,0015
Angular-contact ball bearings	
- single-row	0,0020
- double-row	0,0024
- four-point	0,0024
Self-aligning ball bearings	0,0010
Cylindrical roller bearings	
- with cage while $F_a = 0$	0,0011
- complete with rollers while $F_a = 0$	0,0020
Tapered-roller bearings	0,0018
Spherical-roller bearings	0,0018
Thrust ball bearings	0,0013
Thrust cylindrical roller bearings	0,0050
Spherical-roller thrust bearings	0,0018

Hydrodynamic frictional torque depends on lubrication, bearing size and speed:

$$M_0 = f_0 \cdot d_m^3 \cdot (\nu \cdot n)^{k_0}$$

- f_0 constant lubrication for bearings of same series, design, and precision [-]
- d_m bearing mean diameter [mm]
- ν kinematic viscosity of lubricant [$\text{mm}^2 \cdot \text{s}^{-1}$]
- n revolutions [min^{-1}]
- k_0 constant equal to 2/3 [-]

The rolling friction torque depends on load, the static load, and bearing size:

$$M_1 = f_{\alpha'} \cdot F \cdot d_m \cdot (F/C_0)^c$$

- $f_{\alpha'}$ function of the load bearing direction for bearings of same series, design, and precision [-]
- F load [N]
- d_m bearing mean diameter [mm]
- C_0 static load rating of bearing [N]
- c experimentally determined exponent [-]

A more accurate computational model takes into account four sources of friction:

$$M = M_{rr} + M_{sl} + M_{seal} + M_{drag}$$

M	total frictional torque	[N·mm]
M_{rr}	rolling friction torque	[N·mm]
M_{sl}	sliding friction torque	[N·mm]
M_{seal}	frictional torque within the bearing	[N·mm]
M_{drag}	frictional torque caused by wading	[N·mm]

The calculation using this model, however, is considerably complicated.

6.2 Limiting speed

Bearing operating speeds are limited by the bearing internal design, their precision and size, bearing clearance, method of lubrication and loading design, which affect the dissipation of heat, generated by the bearing. Due to the specified influences, proper attention should be given when designing a suitable bearing.

By limiting speed, we mean the revolutions during which, under given operating conditions, a thermal equilibrium is created between the heat generated in the bearing and the heat released from the bearing.

We are able to state, on the basis of experimental tests and practical applications, that there is a maximum speed that should not be exceeded for technical or economic reasons that are required to maintain the operating temperature at an acceptable level.

If the bearing is to operate at speeds that exceed the limiting speed, the lubrication, method of heat dissipation, the cage design, or the entire bearing design, resp. need to be modified. Manufacturers, for example, recommend that high speed bearings be designed with advanced precision or with the use of a sturdy cage guided on one of the bearing rings and with the use of oil or oil-mist lubrication.

6.2.1 Definition of ZKL limiting speed

The catalogue tables specify the limiting speeds that are defined as the thermal reference speeds in accordance with ISO 15312:2003. The reference conditions that determine the thermal equilibrium are: A temperature increase by 50 °C above the ambient temperature and a 5 % bearing static load range. These conditions apply for opened bearings with normal radial clearance.

Limiting speeds of rolling bearings, as specified in the catalogue tables, are reference speeds for oil lubrication without EP additives with a kinematic viscosity at a temperature of 70 °C as follows: 12 mm²/s or 24 mm²/s, resp. for line-contact thrust bearings.

Limiting speeds for grease lubrication are approximately 20 % lower.

The limiting speed is calculated using the following conditions of thermal equilibrium:

$$n_{mez} = \frac{(W_s (T_{(0,max)} - T_0) - \sum Q_i)}{j \cdot M}$$

W_s cooling coefficient

$T_{(0,max)}$ max. temperature on outer ring

T_0 ambient temperature

Q heat

j mechanical equivalent

M total frictional torque

After modification and substitution, we arrive at the limiting speed equation:

$$n_{mez}^{\frac{5}{3}} + n \cdot \frac{f'_\alpha \cdot F \cdot \left(\frac{F}{C_0}\right)^\epsilon}{f'_0 \cdot d_m^2 \cdot \nu^{\frac{2}{3}}} - \frac{W_s (T_{(0,max)} - T_0) - \sum Q_i}{j \cdot f'_0 \cdot d_m^3 \cdot \nu^{\frac{2}{3}}} = 0$$

f'_0 function of bearing lubrication effect of same series, design, and precision [-]

The given equation has only one real root, while this root physically corresponds to the value of the limiting speed.

The limiting speed values can be approximately determined according to the following relationships:

- for radial bearings:

$$n_{mez} = \frac{(A \cdot f)}{d_m}$$

A coefficient dependent on the bearing series and lubricant [-]

f bearing loading and size effect function [-]

- for thrust bearings:

$$n_{mez} = \frac{(A \cdot f)}{\sqrt{(D \cdot H)}}$$

D bearing external diameter [mm]

H bearing height [mm]

Experimentally, the limiting revolution speed is then determined during radial loading, which corresponds to the durability $L_h = 104 \div 105$ hours such that the speed gradually changes and the steady temperature on the bearing outer ring is recorded. The limiting speed is then determined as the intersection point of the linear estimate of measured values and the limiting reference values (fig. 6.1).

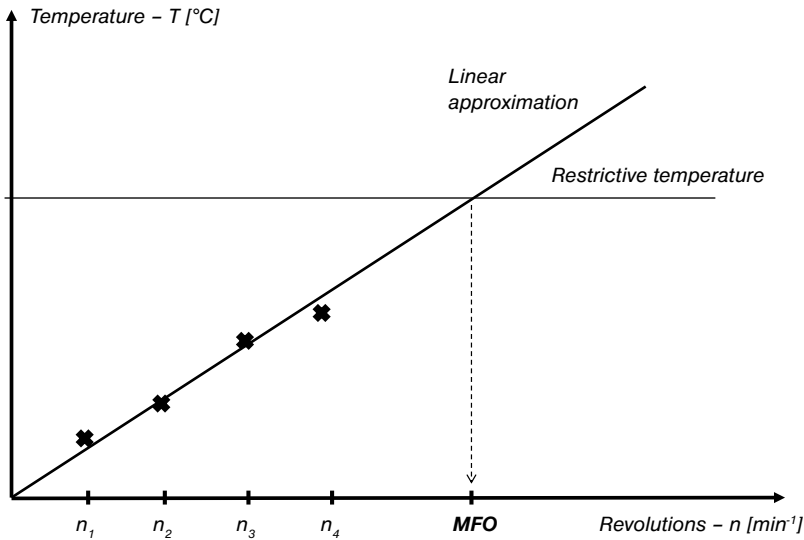

Fig. 6.1

Coefficient A for determining the approximate limiting speed is specified in table 6.2

6.2.2 Special operating speeds

When operating speeds are very low, the elastohydrodynamic lubrication film is not formed at the rolling contact site. Such loadings subsequently require the use of lubricant with EP additives.

Table 6.2

Bearing type	Coefficient A
Single-row ball	500 000
Single-row ball with RS and 2RS glands	300 000
Single-row angular-contact ball	
$\alpha \leq 15^\circ$	500 000
$\alpha = 26^\circ$	420 000
$\alpha = 40^\circ$	400 000
Double-row angular-contact ball	320 000
Single-row cylindrical roller	500 000
Double-row cylindrical roller	500 000
Double-row spherical-roller, except for series 232	250 000
Double-row spherical-roller series 232	200 000
Tapered-roller, except for series 313	250 000
Tapered-roller series 313	200 000
Thrust ball	100 000
Thrust cylindrical roller	100 000
Spherical-roller thrust	200 000

Oscillation motions are another special case. In this type of motion, the direction of rotation changes before the bearing completes one revolution. The speed is zero at the moment the direction of rotation changes and, as such, the hydrodynamic lubricating film is not preserved. The lubricating film is formed, in such case, in the area of mixed lubrication. The limiting speed cannot be determined for oscillations, because the upper threshold is not determined by thermal equilibrium, by non-inertial forces. There is a risk that inertia may cause short-term slippage of rolling elements and damage to orbits each time the direction of rotation changes. Permissible acceleration or deceleration, resp. depends on the mass of the rolling elements and the cage, the lubrication, and the bearing loading.

6.3 Vibrations in the bearing

Sensing of vibrations is generally related to the propagation of noise. The bearing, however, is usually not the source of noise. Noise is just an audible effect of vibrations that are caused either directly or indirectly by the bearing on related components. It is the reason why the majority of noise-related issues are associated with vibrations of the bearing itself or the entire housing.

The number of rolling elements, which carry the load, changes during operation in radially loaded bearings. This effect causes a displacement in the direction of the load. While the resulting vibrations cannot be prevented, they may be reduced by introducing an axial preload that ensures loading of all rolling elements.

Roll-over of damaged bearing components occurs in cases of local damage to raceways or rolling elements, resp., which occurs during improper handling or incorrect installation, and it leads to vibrations. The source of vibrations (damaged component) can be determined using vibration frequency analysis.

Penetration of contaminants into the bearing may occur in bearings that operate in contaminated environments when rolling elements roll over the contaminants. The size of induced vibrations depends on the quantity, size, and structure of the contaminants. This does not generate typical frequencies, but an audible noise may be heard.

6.3.1 Frequency characteristics of bearings

The frequency of vibration impulses created by toss-over of damaged bearing components has a simple relationship to the internal bearing geometry and to the frequency of shaft revolutions. These relationships can be described using equations that define the frequency of defects of individual bearing components. The specified equations assume optimal conditions, because they do not account for slippage of rolling elements. The equation for ball defects presupposes that the defect touches both the inner and outer ring per revolution of the rolling element.

The frequency during a defect on the outer ring (BPFO)

$$\text{BPFO} = z/2 \cdot n \cdot (1 - D_w/d_m \cdot \cos \alpha)$$

The frequency during a defect on the inner ring (BPFI)

$$\text{BPFI} = z/2 \cdot n \cdot (1 + D_w/d_m \cdot \cos \alpha)$$

The frequency during a ball- or roller defect (BSF).

$$\text{BSF} = d_m / 2D_w \cdot n \cdot (1 - (D_w/d_m)^2)$$

Frequency during a cage defect (FTF)

$$\text{FTF} = n/2 \cdot (1 - D_w/d_m \cdot \cos \alpha)$$

- : D_w roller element diameter (mm) [mm]
- d_m bearing pitch diameter (mm) [mm]
- z number of rolling elements
- n shaft rotation frequency [s⁻¹]
- α contact angle

Vibration frequency analyses help determine, which bearing component is damaged. We recommend that the customer coordinates with ZKL Technical and Consulting Services Department when calculating frequency characteristics.

6.3.2 Influence of the bearing on housing vibrations

The rigidity of the bearing is, in many housings, of the same order as the rigidity of related components. Housing vibrations can be reduced by the proper selection of the bearing, the arrangement of bearings in the housing, and by using a suitable preload or clearance. If the vibrations cannot be eliminated by the selective use of the bearing, its arrangement within the housing, the vibrations may also be reduced by additional modifications of the housing, e.g. by inserting a rubber spacer that will dampen the vibrations or any other structural modification that will eliminate the source of critical vibrations.



7. BEARINGS – GENERAL DATA

7.1 Bearing design data

Besides the suitable type of bearing and the size of it, additional design characteristics that define the bearing in location design have to be defined. The location designed is the one usually responsible for the bearing design. This person has to consider the requirements for accuracy of run, service temperature and lubrication, as well as the assembly and disassembly method. In order to meet all different requirements for proper run of bearing, bearings are produced in many versions that are characterized with an additional identification of bearings. Thus, bearings with required tolerances, clearances, materials, cage design or sealing can be selected. Also, accordingly with the identification system, bearings can be specified for certain service conditions that may be characteristic with high revolutions or high temperature, or alternatives of bearings for certain locations can be selected by the knowledge of identification of other bearing manufacturers.

7.2 Main dimensions

Rolling bearings are supplied as a final machine part, and the designer has at disposal fixed dimensions that ensure easy exchangeability. Standardisation applies to outer dimensions important in the assembly point of view. It is convenient for manufacturers and users of bearings for technological and thus also economic reasons. It however does not state inner dimensions, such as the quantity and dimensions of rolling bodies, or designs of cages. Despite that, due to the long-term development and various design and production technology optimisations even the inner design of bearings becomes united to a significant extent.

The ISO international organization came up with dimension plans for roller bearings of metric dimensions that are defined in the below listed documents:

- ISO 15:1998 applies to radial roller bearings of metric dimensions, with the exception of tapered bearings;
- ISO 355:1997 applies to radial tapered bearings of metric dimensions;
- ISO 104:2002 applies to thrust roller bearings of metric dimensions;
- ISO 582:1995 applies to maximum values of bevelling the assembly edges of bearings.

7.2.1 ISO dimension plans

ISO dimension plan allocates to each bearing hole diameter d multiple outer diameters D , and to those different widths B – or – more precisely - T for radial and H for thrust bearings. Bearings with the same hole diameter and same outer diameter belong in one diameter row identified by ascending outer diameter with figures 7, 8, 9, 0, 1, 2, 3, 4. Every diameter row contains bearings of different width rows by ascending width: 8, 0, 1, 2, 3, 4, 5, 6 and 7 for radial bearings. Width rows of radial bearings correspond with height rows of thrust bearings (height rows by ascending height 7, 9, 1 and 2).

Combining the diameter and width row creates dimension rows that are identified by double figure where the first figure identified the width row, and the second figure identifies the diameter row. This system is clearly indicated in fig. 7.1.

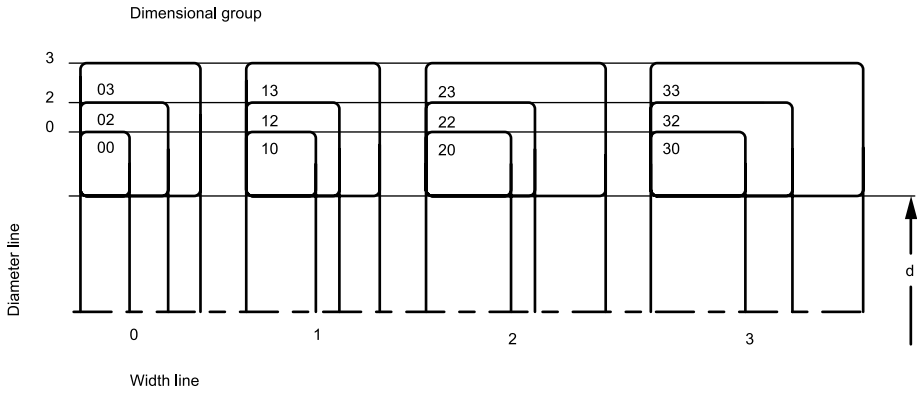

Fig. 7.1

The ISO dimension plan also contains dimensions of bearing ring edge fillet, the so-called installation fillet (fig. 7.2). The chart section of the catalogue indicates minimum installation fillet values for individual bearing types that you need to know when designing radiuses of transmission of components forming the bearing location.

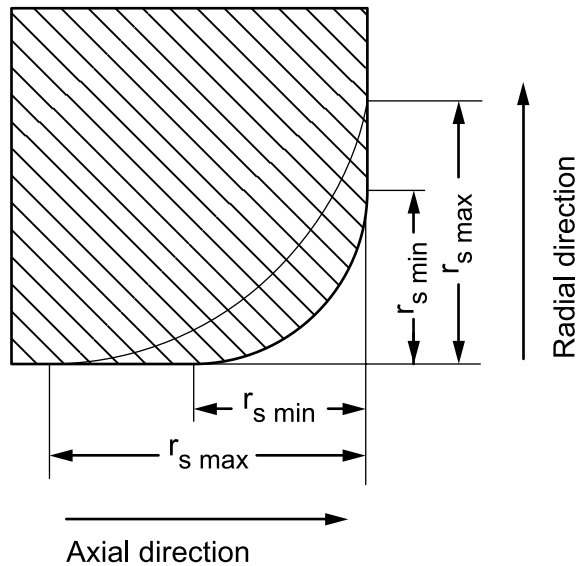

Fig. 7.2

See Chart 7.1 for an overview of the installation fillet complying with the international standard ISO 582.

Table 7.1

Limit dimensions of installation fillet									
$r_{s \text{ min}}$ mm	Radial bearings except tapered				Tapered bearings				Thrust bearings
	d or D		$r_{s \text{ min}}$		d or D		$r_{s \text{ min}}$		$r_{s \text{ min}}$
	over	to	in radial direction	in axial direction	over	to	in radial direction	in axial direction	in radial and axial direction
0,15	-	-	0,3	0,6	-	-	-	-	0,3
0,2	-	-	0,5	0,8	-	-	-	-	0,5
0,3	-	40	0,6	1	-	40	0,7	1,4	0,8
	40	-	0,8	1	40	-	0,9	1,6	0,8
0,6	-	40	1	2	-	40	1,1	1,7	1,5
	40	-	1,3	2	40	-	1,3	2	1,5
1	-	50	1,5	3	-	50	1,6	2,5	2,2
	50	-	1,9	3	50	-	1,9	3	2,2
1,1	-	120	2	3,5	-	-	-	-	2,7
	120	-	2,5	4	-	-	-	-	2,7
1,5	-	120	2,3	4	-	120	2,3	3	3,5
	120	-	3	5	120	250	2,8	3,5	3,5
	-	-	-	-	250	-	3,5	4	3,5
2	-	80	3	4,5	-	120	2,8	4	4
	80	220	3,5	5	120	250	3,5	4,5	4
	220	-	3,8	6	250	-	4	5	4
2,1	-	280	4	6,5	-	-	-	-	4,5
	280	-	4,5	7	-	-	-	-	4,5
2,5	-	100	3,8	6	-	120	3,5	5	-
	100	280	4,5	6	120	250	4	5,5	-
	280	-	5	7	250	-	4,5	6	-
3	-	280	5	8	-	120	4	5,5	5,5
	280	-	5,5	8	120	250	4,5	6,5	5,5
	-	-	-	-	250	400	5	7	5,5
	-	-	-	-	400	-	5,5	7,5	5,5
4	-	-	6,5	9	-	120	5	7	6,5
	-	-	-	-	120	250	5,5	7,5	6,5
	-	-	-	-	250	400	6	8	6,5
	-	-	-	-	400	-	6,5	8,5	6,5
5	-	-	8	10	-	180	6,5	8	8
	-	-	-	-	180	-	7,5	9	8
6	-	-	10	13	-	180	7,5	10	10
	-	-	-	-	180	-	9	11	10
7,5	-	-	12,5	17	-	-	-	-	12,5
9,5	-	-	15	19	-	-	-	-	15
12	-	-	18	24	-	-	-	-	18
15	-	-	21	30	-	-	-	-	21

7.2.2 Accuracy of bearings

Accuracy of bearings means accuracy of bearing dimensions and run. Bearings are made in the accuracy classes P0, P6, P5, P5A, P4, P4A, P2, SP and UP. The P0 accuracy is general, and is not stated in the bearing identification. Descending number in the identification indicates higher bearing accuracy.

Majority locations can utilise roller bearings of normal accuracy level. Bearings with higher accuracy level are used in locations that require higher running accuracy, such as location of machine tool spindles, and where bearings exceed their limit revolutions.



The limit dimension and run accuracy values are stated in charts 7.2 to 7.12. These values comply with international standards ISO 492 a ISO 199. The P5A and P4A designation is used for bearings made in relevant accuracy level P5 and P4 but selected parameters feature higher accuracy level than is P5 and P4.

Symbols of quantities and their meaning

- d nominal bore diameter
- d_1 nominal diameter of bigger theoretical tapered bore diameter
- d_2 nominal diameter of shaft ring of double direction thrust bearings
- Δd_s deviation of individual bore diameter from nominal dimension
- Δd_{mp} deviation of mean diameter of cylindrical bore in individual radial plane (for tapered bore applies Δd_{mp} for theoretical bore diameter)
- Δd_{1mp} deviation of mean theoretical tapered bore diameter
- Δd_{2mp} deviation of mean shaft ring bore diameter of double direction thrust bearings in individual radial plane
- V_{dp} dispersion of individual bore diameter in individual radial plane
- V_{dmp} dispersion of mean cylindrical bore diameter
- V_{d2p} dispersion of shaft ring bore diameter of double direction thrust bearings in individual radial plane
- D nominal external diameter
- ΔD_s deviation of individual outer diameter from nominal dimension
- ΔD_{mp} deviation of mean diameter of cylindrical surface in individual radial plane
- V_{Dp} dispersion of individual outer cylindrical surface diameter in individual radial plane
- $V_{D_{mp}}$ dispersion of mean outer cylindrical bore diameter
- B nominal inner ring width
- T nominal total width of tapered bearings
- T_1 nominal effective width of inner semi-unit
- T_2 nominal effective width of outer semi-unit
- ΔB_s deviation of individual inner ring width
- ΔC_s deviation of individual outer ring width

- ΔT_s deviation of (total) individual bearing width
- ΔT_{1s} deviation of effective width of inner semi-unit
- ΔT_{2s} deviation of effective width of outer semi-unit
- C nominal outer ring width
- V_{Bs} dispersion of individual inner ring width
- V_{Cs} dispersion of individual outer ring width
- K_{ia} radial runout of assembled bearing inner ring
- K_{ea} radial runout of assembled bearing outer ring
- S_1 axial runout of shaft ring raceway
- S_e axial runout of body ring raceway
- S_{ia} axial runout of basic front of assembled bearing inner ring
- S_{ea} axial runout of basic front of assembled bearing outer ring
- S_d axial runout of basic front
- $S_{D'}$ runout of outer surface against ring front
- S_s runout of inner ring support front against basic front for single row tapered bearings

Limit values of individual parameters for different accuracy levels are stated in the below charts.

Table 7.2

Accuracy of dimensions and run of radial bearings (except tapered)																
Accuracy level P0																
Inner ring																
d		Δ_{dmp}		V_{dp} diameter rows 7,8,9 0,1 2,3,4			V_{dmp}	K_{ia}	Δ_{Bs}		V_{Bs}	Δ_{dmp}		Δ_{d1mp}	$-\Delta_{dmp}$	$V_{dp}^{(1)}$
over	to	max	min	max	max	max	max	max	min	max	max	min	max	min	max	
mm		μm														
2,5	10	0	-8	10	8	6	6	10	0	-120	15	-	-	-	-	-
10	18	0	-8	10	8	6	6	10	0	-120	20	-	-	-	-	-
18	30	0	-10	13	10	8	8	13	0	-120	20	21	0	21	0	13
30	50	0	-12	15	12	9	9	15	0	-120	20	25	0	25	0	15
50	80	0	-15	19	19	11	11	20	0	-150	25	30	0	30	0	19
80	120	0	-20	25	25	15	15	25	0	200	25	35	0	35	0	25
120	180	0	-25	31	31	19	19	30	0	-250	30	40	0	40	0	31
180	250	0	-30	38	38	23	23	40	0	-300	30	46	0	46	0	38
250	315	0	-35	44	44	26	26	50	0	-350	35	52	0	52	0	44
315	400	0	-40	50	50	30	30	60	0	-400	40	57	0	57	0	50
400	500	0	-45	56	56	34	34	65	0	-450	50	63	0	63	0	56
500	630	0	-50	63	63	38	38	70	0	-500	60	-	-	-	-	-
630	800	0	-75	-	-	-	-	80	0	-750	70	-	-	-	-	-
800	1000	0	-100	-	-	-	-	90	0	-1000	80	-	-	-	-	-
1000	1250	0	-125	-	-	-	-	100	0	-1250	100	-	-	-	-	-

Table 7.3

Outer ring											
D		ΔD_{mp}		V_{DP} Diameter rows 7,8,9 0,1 2,3,4 bearings ²⁾ with shields				V_{Dmp}	K_{ea}	Δ_{Cs}, Δ_{Cs}	
přes	do	max	min	max	max	max	max	max	max		
mm		μm									
6	18	0	-8	10	8	6	10	6	15		
18	30	0	-9	12	9	7	12	7	15		
30	50	0	-11	14	11	8	16	8	20		
50	80	0	-13	16	13	10	20	10	25		
80	120	0	-15	19	19	11	26	11	35		
120	150	0	-18	23	23	14	30	14	40		
150	180	0	-25	31	31	19	38	19	45		
180	250	0	-30	38	38	23	-	23	50		
250	315	0	-35	44	44	26	-	26	60		
315	400	0	-40	50	50	30	-	30	70		
400	500	0	-45	56	56	34	-	34	80		
500	630	0	-50	63	63	38	-	38	100		
630	800	0	-75	94	94	55	-	55	120		
800	1000	0	-100	125	125	75	-	75	140		
1000	1250	0	-125	-	-	-	-	-	160		
1250	1600	0	-160	-	-	-	-	-	190		

¹⁾ Applies in optional radial bore plane
²⁾ Applies only to bearings of diameter rows 2, 3 and 4
³⁾ Corresponds with Δ_{Bs}, V_{Bs} of inner race of the same bearing

Table 7.4a

Accuracy of dimensions and run of radial bearings (except tapered)											
Accuracy level P6											
Inner ring											
d		Δ_{dmp}		V_{dp}			V_{dmp}	K_{ia}	Δ_{Bs}		V_{Bs}
				Diameter rows							
over	to	max	min	7,8,9	0,1	2,3,4	max	max	max	min	max
mm		μm									
2,5	10	0	-7	9	7	5	5	6	0	-120	15
10	18	0	-7	9	7	5	5	7	0	-120	20
18	30	0	-8	10	8	6	6	8	0	-120	20
30	50	0	-10	13	10	8	8	10	0	-120	20
50	80	0	-12	15	15	9	9	10	0	-150	25
80	120	0	-15	19	19	11	11	13	0	-200	25
120	180	0	-18	23	23	14	14	18	0	-250	30
180	250	0	-22	28	28	17	17	20	0	-300	30
250	315	0	-25	31	31	19	19	25	0	-350	35
315	400	0	-30	38	38	23	23	30	0	-400	40
400	500	0	-35	44	44	26	26	35	0	-450	45
500	630	0	-40	50	50	30	30	40	0	-500	50

Table 7.4b

Outer ring											
D		ΔD_{mp}		V_{DP}				V_{Dmp}	K_{es}	Δ_{Cs}, V_{Cs}	
				Diameter rows							
over	to	max	min	7,8,9	0,1	2,3,4	bearings ¹⁾ with shields	max	max		
mm		μm									
6	18	0	-7	9	7	5	9	5	8		
18	30	0	-8	10	8	6	10	6	9		
30	50	0	-9	11	9	7	13	7	10		
50	80	0	-11	14	11	8	16	8	13		
80	120	0	-13	16	16	10	20	10	18		
120	150	0	-15	19	19	11	25	11	20		
150	180	0	-18	23	23	14	30	14	23		
180	250	0	-20	25	25	15	-	15	25		
250	315	0	-25	31	31	19	-	19	30		
315	400	0	-28	35	35	21	-	21	35		
400	500	0	-33	41	41	25	-	25	40		
500	630	0	-38	48	48	29	-	29	50		
630	800	0	-45	56	56	34	-	34	60		
800	1000	0	-50	75	75	45	-	45	75		

¹⁾ Applies only to bearings of diameter rows 0, 1, 2, 3 and 4
²⁾ Corresponds with Δ_{Bs}, V_{Bs} of the inner race of the same bearing

Table 7.5

Accuracy of dimensions and run of radial bearings (except tapered)												
Accuracy level P5												
Inner ring												
d		Δ_{dmp}		V_{dp}		V_{dmp}	K_{ia}	S_d	$S_{ia}^{1)}$	Δ_{Bs}		V_{Bs}
over	to	max	min	Diameter rows		max	max	max	max	max	min	max
mm		μm										
				7,8,9	0,1,2,3,4							
2,5	10	0	-5	5	4	3	4	7	7	0	-40	5
10	18	0	-5	5	4	3	4	7	7	0	-80	5
18	30	0	-6	6	5	3	4	8	8	0	-120	5
30	50	0	-8	8	6	4	5	8	8	0	-120	5
50	80	0	-9	9	7	5	5	8	8	0	-150	6
80	120	0	-10	10	8	5	6	9	9	0	-200	7
120	180	0	-13	13	10	7	8	10	10	0	-250	8
180	250	0	-15	15	12	8	10	11	13	0	-300	10
250	315	0	-18	18	14	9	13	13	15	0	-350	13
315	400	0	-23	23	18	12	15	15	20	0	-400	15

Table 7.6

Outer ring												
D		ΔD_{mp}		V_{DP}		V_{Dmp}	K_{ea}	S_D	$S_{ea}^{1)}$	Δ_{Cs}	V_{Cs}	
over	to	max	min	Diameter rows		max	max	max	max		max	
mm		μm										
				7,8,9	0,1 2,3,4							
6	18	0	-5	5	4	3	5	8	8		5	
18	30	0	-6	6	5	3	6	8	8		5	
30	50	0	-7	7	5	4	7	8	8		5	
50	80	0	-9	9	8	5	8	8	10		6	
80	120	0	-10	10	8	5	10	9	11	Odpovídá ΔBc vnitřního kroužku téžhož ložiska	8	
120	150	0	-11	11	8	6	11	10	13		8	
150	180	0	-13	13	10	7	13	10	14		8	
180	250	0	-15	15	11	8	15	11	15		10	
250	315	0	-18	18	14	9	18	13	18		11	
315	400	0	-20	20	15	10	20	13	20		13	
400	500	0	-23	23	17	12	23	15	23		15	
500	630	0	-28	28	21	14	25	18	25		18	
630	800	0	-35	35	26	18	30	20	30		20	

¹⁾ Applies to ball bearings only

²⁾ Does not apply to shielded bearings

³⁾ Corresponds with Δ_{Bc} of the inner ring of the same bearing

Table 7.7

Accuracy of dimensions and run of radial bearings (except tapered)														
Accuracy level P4														
Inner ring														
d		Δ_{dmp}		$\Delta_{ds}^{1)}$		V_{dp}		V_{dmp}	K_{ia}	S_d	$S_{ia}^{2)}$	Δ_{Bs}		V_{Bs}
						Diameter rows								
						7,8,9	0,1,2,3,4							
over	to	max	min	max	min	max	max	max	max	max	max	max	min	max
mm		μm												
2,5	10	0	-4	0	-4	4	3	2	2,5	3	3	0	-40	2,5
10	18	0	-4	0	-4	4	3	2	2,5	3	3	0	-80	2,5
18	30	0	-5	0	-5	5	4	2,5	3	4	4	0	-120	2,5
30	50	0	-6	0	-6	6	5	3	4	4	4	0	-120	3
50	80	0	-7	0	-7	7	5	3,5	4	5	5	0	-150	4
80	120	0	-8	0	-8	8	6	4	5	5	5	0	-200	4
120	180	0	-10	0	-10	10	8	5	6	6	7	0	-250	5
180	250	0	-12	0	-12	12	9	6	8	7	8	0	-300	6

Table 7.8

Outer ring														
D		ΔD_{mp}		$V_{Ds}^{1)}$		V_{DP}		V_{Dmp}	K_{ea}	S_D	$S_{ea}^{2)}$	Δ_{Cs}	V_{Cs}	
						Diameter rows ³⁾								
						7,8,9	0,1 2,3,4							
over	to	max	min	max	min	max	max	max	max	max	max		max	
mm		μm												
6	18	0	-4	0	-4	4	3	2	3	4	5		2,5	
18	30	0	-5	0	-5	5	4	2,5	4	4	5		2,5	
30	50	0	-6	0	-6	6	5	3	5	4	5		2,5	
50	80	0	-7	0	-7	7	5	3,5	5	4	5		3	
80	120	0	-8	0	-8	8	6	4	6	5	6		4	
120	150	0	-9	0	-9	9	7	5	7	5	7		5	
150	180	0	-10	0	-10	10	8	5	8	5	8		5	
180	250	0	-11	0	-11	11	8	6	10	7	10		7	
250	315	0	-13	0	-13	13	10	7	11	8	10		7	
315	400	0	-15	0	-15	15	11	8	13	10	13		8	

¹⁾ Applies only to bearings of diameter rows 0, 1, 2, 3 and 4
²⁾ Applies to ball bearings only
³⁾ Does not apply to shielded bearings
⁴⁾ Corresponds with Δ_{Bs} of the inner ring of the same bearing

Table 7.9

Accuracy of dimensions and run of roller bearings with tapered hole												
Accuracy level SP												
Inner ring												
d		Δ_{dmp}		Δ_{d1mp}	$-\Delta_{dmp}$	V_{dp}	K_{ia}	S_d	Δ_{Bs}		V_{Bs}	
over	to	max	min	max	min	max	max	max	max	min	max	
mm		μm										
18	30	10	0	4	0	3	3	8	0	-100	5	
30	50	12	0	4	0	4	4	8	0	-120	5	
50	80	15	0	5	0	5	4	8	0	-150	6	
80	120	20	0	6	0	5	5	9	0	-200	7	
120	180	25	0	8	0	7	6	10	0	-250	8	
180	250	30	0	10	0	8	8	11	0	-300	10	
250	315	35	0	12	0	9	10	13	0	-350	13	
315	400	40	0	13	0	12	12	15	0	-400	15	
400	500	45	0	15	0	14	12	18	0	-450	25	

Table 7.10

Outer ring									
D		ΔD_{mp}		V_{Dp}	K_{eas}	S_D	Δ_{Cs}, V_{Cs}		
over	to	max	min	max	max	max			
mm		μm							
50	80	0	-9	5	5	8	Odpovídá Δ_{Bs} a V_{Bs} vnitřního kroužku téhož ložiska		
80	120	0	-10	5	6	9			
120	150	0	-11	6	7	10			
150	180	0	-13	7	8	10			
180	250	0	-15	8	10	11			
250	315	0	-18	9	11	13			
315	400	0	-20	10	13	13			
400	500	0	-23	12	15	15			
500	630	0	-28	14	17	18			
630	800	0	-35	18	20	20			

¹⁾ Corresponds with Δ_{Bs} and V_{Bs} of inner ring of the same bearing

Table 7.11a

Accuracy of dimensions and run of roller bearings with tapered hole												
Accuracy level UP												
Inner ring												
d		Δ_{dmp}		Δ_{d1mp}	$-\Delta_{dmp}$	V_{dp}	K_{ia}	S_d	Δ_{Bs}		V_{Bs}	
over	to	max	min	max	min	max	max	max	max	min	max	
mm		μm										
18	30	6	0	2	0	3	1,5	3	0	-25	1,5	
30	50	7	0	3	0	3	2	3	0	-30	2	
50	80	8	0	3	0	4	2	4	0	-40	3	
80	120	10	0	4	0	4	3	4	0	-50	3	
120	180	12	0	5	0	5	3	5	0	-60	4	
180	250	14	0	6	0	6	4	6	0	-75	5	
250	315	17	0	8	0	8	5	6	0	-90	6	

Table 7.11b

Outer ring												
D		Δ_{Dmp}		V_{Dp}	K_{oa}	S_o	Δ_{Cs}, V_{Cs}					
over	to	max	min	max	max	max						
mm		μm										
50	80	0	-6	3	3	2	Odpovídá Δ_{Bs} a V_{Bs} vnitřního kroužku téhož ložiska					
80	120	0	-7	4	3	3						
120	150	0	-8	4	4	3						
150	180	0	-9	5	4	3						
180	250	0	-10	5	5	4						
250	315	0	-12	6	6	4						
315	400	0	-14	7	7	5						

¹⁾ Corresponds with Δ_{Bs} and V_{Bs} of inner ring of the same bearing

Table 7.12a

Accuracy of dimensions and run of tapered bearings														
Accuracy level P0														
Inner ring and total bearing width														
d		Δ_{dmp}		V_{dp}	V_{dmp}	K_{ia}	Δ_{Bs}		Δ_{Ts}		Δ_{T1s}		Δ_{T2s}	
over	to	max	min	max	max	max	max	min	max	min	max	min	max	min
mm		μm												
10	18	0	-12	12	9	15	0	-120	200	0	100	0	100	0
18	30	0	-12	12	9	18	0	-120	200	0	100	0	100	0
30	50	0	-12	12	9	20	0	-120	200	0	100	0	100	0
50	80	0	-15	15	11	25	0	-150	200	0	100	0	100	0
80	120	0	-20	20	15	30	0	-200	200	-200	100	-100	100	-100
120	180	0	-25	25	19	35	0	-250	350	-250	150	-150	200	-100
180	250	0	-30	30	23	50	0	-300	350	-250	150	-150	200	-100

Table 7.12b

Outer ring									
D		Δ_{Dmp}		V_{Dp}	V_{Dmp}	K_{ea}	Δ_{Cs}		
over	to	max	min	max	max	max	max	min	min
mm		μm							
18	30	0	-12	12	9	18	0	-120	
30	50	0	-14	14	11	20	0	-120	
50	80	0	-16	16	12	25	0	-150	
80	120	0	-18	18	14	35	0	-200	
120	150	0	-20	20	15	40	0	-250	
150	180	0	-25	25	19	45	0	-250	
180	250	0	-30	30	23	50	0	-300	
250	315	0	-35	35	26	60	0	-350	
315	400	0	-40	40	30	70	0	-400	

Table 7.13a

Accuracy of dimensions and run of tapered bearings															
Accuracy level P6X															
Inner ring and total bearing width															
d		Δ_{dmp}		V_{dp}	V_{dmp}	K_{ia}	Δ_{Bs}		Δ_{Ts}		Δ_{T1s}		Δ_{T2s}		
over	to	max	min	max	max	max	max	min	max	min	max	min	max	min	
mm		μm													
10	18	0	-12	12	9	15	0	-50	100	0	50	0	50	0	
18	30	0	-12	12	9	18	0	-50	100	0	50	0	50	0	
30	50	0	-12	12	9	20	0	-50	100	0	50	0	50	0	
50	80	0	-15	15	11	25	0	-50	100	0	50	0	50	0	
80	120	0	-20	20	15	30	0	-50	100	0	50	0	50	0	
120	180	0	-25	25	19	35	0	-50	150	0	50	0	100	0	

Table 7.13b

Outer ring									
D		Δ_{Dmp}		V_{Dp}	V_{Dmp}	K_{ea}	Δ_{Cs}		
over	to	max	min	max	max	max	max	min	min
mm		μm							
18	30	0	-12	12	9	18	0	-100	
30	50	0	-14	14	11	20	0	-100	
50	80	0	-16	16	12	25	0	-100	
80	120	0	-18	18	14	35	0	-100	
120	150	0	-20	20	15	40	0	-100	
150	180	0	-25	25	19	45	0	-100	
180	250	0	-30	30	23	50	0	-100	
250	315	0	-35	35	26	60	0	-100	

Table 7.14a

Accuracy of dimensions and run of tapered bearings								
Accuracy level P6								
Inner ring and total bearing width								
d		Δ_{dmp}		K_{ia}	Δ_{Bs}		Δ_{Ts}	
over	to	max	min	max	max	min	max	min
mm		μm						
10	18	0	-7	7	0	-200	200	0
18	30	0	-8	8	0	-200	200	0
30	50	0	-10	10	0	-240	200	0
50	80	0	-12	10	0	-300	200	0
80	120	0	-15	13	0	-400	200	-200
120	180	0	-18	18	0	-500	350	-250

Table 7.14b

Outer ring					
D		Δ_{Dmp}		K_{ea}	Δ_{Cs}
over	to	max	min	max	
mm		μm			
18	30	0	-8	9	Odpovídá Δ_{Bs} vnitřního kroužku téžhož ložiska
30	50	0	-9	10	
50	80	0	-11	13	
80	120	0	-13	18	
120	150	0	-15	20	
150	180	0	-18	23	
180	250	0	-20	25	
250	315	0	-25	30	

¹⁾ Corresponds with Δ_{Bs} of inner ring of the same bearing

Table 7.15a

Accuracy of dimensions and run of tapered bearings											
Accuracy level P5											
Inner ring and total bearing width											
d		Δ_{dmp}		V_{dp}	V_{dmp}	K_{ia}	\dot{S}_d	Δ_{Bs}		Δ_{Ts}	
over	to	max	min	max	max	max	max	max	min	max	min
mm		μm									
10	18	0	-7	5	5	5	7	0	-200	200	-200
18	30	0	-8	6	5	5	8	0	-200	200	-200
30	50	0	-10	8	5	5	8	0	-240	200	-200
50	80	0	-12	9	6	7	8	0	-300	200	-200
80	120	0	-15	11	8	8	9	0	-400	200	-200
120	180	0	-18	14	9	11	10	0	-500	350	-250

Table 7.15b

Outer ring									
D		Δ_{Dmp}		V_{Dp}	V_D	K_{ea}	\dot{S}_D	Δ_{Cs}	
over	to	max	min	max	max	max	max		
mm		μm							
18	30	0	-8	6	5	6	8	Odpovídá Δ_{Bs} vnitřního kroužku téhož ložiska	
30	50	0	-9	7	5	7	8		
50	80	0	-11	8	6	8	8		
80	120	0	-13	10	7	10	9		
120	150	0	-15	11	8	11	10		
150	180	0	-18	14	9	13	10		
180	250	0	-20	15	10	15	11		
250	315	0	-25	19	13	18	13		

¹⁾ Corresponds with Δ_{Bs} of the inner ring of the same bearing

Table 7.16a

Accuracy of dimensions and run of axial bearings							
Accuracy level P0, P6 and P5							
Shaft ring							
d		Δ_{dmp}		V_{dp}	S_i	¹⁾	
over	to	max	min	max	P0	P6	P5
mm		μm					
-	18	0	-8	6	10	5	3
18	30	0	-10	8	10	5	3
30	50	0	-12	9	10	6	3
50	80	0	-15	11	10	7	4
80	120	0	-20	15	15	8	4
120	180	0	-25	19	15	9	5
180	250	0	-30	23	20	10	5
250	315	0	-35	26	25	13	7
315	400	0	-40	30	30	15	7
400	500	0	-45	34	30	18	9
500	630	0	-50	38	35	21	11
630	800	0	-75	-	40	25	13

¹⁾ Does not apply to thrust spherical roller bearings

Table 7.16b

Housing ring							
D		Δ_{Dmp}		V_{Dp}	S_e	¹⁾	
over	to	max	min	max			
mm		μm					
18	30	0	-13	10	Corresponds with S_i of shaft ring of the same bearing		
30	50	0	-16	12			
50	80	0	-19	14			
80	120	0	-22	17			
120	180	0	-25	19			
180	250	0	-30	23			
250	315	0	-35	26			
315	400	0	-40	30			
400	500	0	-45	34			
500	630	0	-50	38			
630	800	0	-75	55			
800	1000	0	-100	75			
1000	1250	0	-125	-			
1250	1600	0	-160	-			

¹⁾ Does not apply to thrust spherical roller bearings

7.2.3 Inner clearances of bearings

Clearance in bearing is the value of length of displacement of one assembled bearing ring towards the second ring from one marginal position to another (see fig. 7.3). The displacement can be in radial direction (radial clearance), or in axial direction (axial clearance).

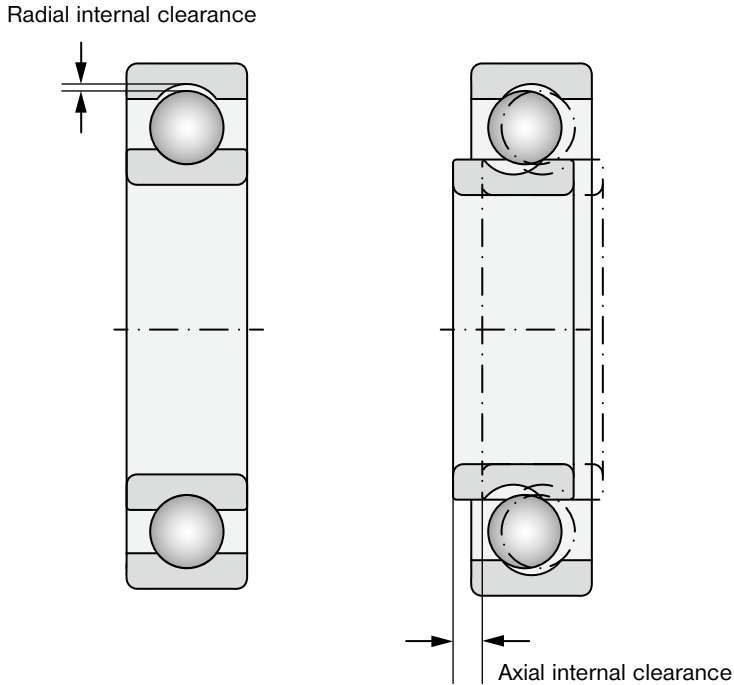

Fig. 7.3

In an in-built bearing we usually detect lower radial clearance than has the same bearing in unassembled state. Reduction of radial clearance is caused by the overlap sizes of bearing rings on the journal and in the body bore, and is therefore dependant on the selected tolerances of location surface diameters for the bearing. Further change of radial clearance, particularly its reduction, takes place during the operation due to temperature induced by the bearing operation itself, and by external sources, and also due to flexible deformations caused by load. Decisive is for bearing in stabilised service effects. Small prestress between the balls and raceways usually does not have negative effect.

Cylindrical roller, tapered roller, spherical roller bearings feature higher rigidity, and therefore they are supposed to have smaller service clearance that is necessary to ensure safe and reliable run, mainly in heavy service conditions. If extremely high rigidity of location is required, e.g. for machine tools, prestressed bearings are mounted.

For normal design bearings the clearance is adjusted so that one of the bearing rings could be located firmly which is sufficient for majority of service ratios in location. Special cases of location with other requirements for radial clearance require bearings with radial clearance designated C1 to C5.

Values of different inner clearance levels according to ISO 5753 standard are for individual design bearing groups stated in charts 7.17 to 7.23 whilst these values apply to non-mounted bearings in zero load during measuring.

Table 7.17a

Radial clearance of single row ball bearings															
Bore diameter		Radial clearance										Single row ball bearings separable of E and BO type	Radial clearance		
d		C2		Normal		C3		C4		C5			min	max	
over	to	min	max	min	max	min	max	min	max	min	max				
mm		µm										µm			
2,5	10	0	7	2	13	8	23	14	29	20	37	E10, E12	15	30	
10	18	0	9	3	18	11	25	18	33	25	45	E15	15	30	
18	24	0	10	5	20	13	28	20	36	28	48	BO17, E17	25	45	
24	30	1	11	5	20	13	28	23	41	30	53	E20	20	40	
30	40	1	11	6	20	15	33	28	46	40	64				
40	50	1	11	6	23	18	36	30	51	45	73				
50	65	1	15	8	28	23	43	38	61	55	90				
65	80	1	15	10	30	25	51	46	71	65	105				
80	100	1	18	12	36	30	58	53	84	75	120				
100	120	2	20	15	41	36	66	61	97	90	140				
120	140	2	23	18	48	41	81	71	114	105	160				
140	160	2	23	18	53	46	91	81	130	120	180				
160	180	2	25	20	61	53	102	91	147	135	200				
180	200	2	30	25	71	63	117	107	163	150	215				
200	225	2	35	25	85	75	140	125	195	175	265				
225	250	2	40	30	95	85	160	145	225	205	300				
250	280	2	45	35	105	90	170	155	245	225	340				
280	315	2	55	40	115	100	190	175	270	245	370				
315	355	3	60	45	125	110	210	195	300	275	410				
355	400	3	70	55	145	130	240	225	340	315	460				
400	450	3	80	60	170	150	270	250	380	350	520				
450	500	3	90	70	190	170	300	280	420	390	570				
500	560	10	100	80	210	190	330	310	470	440	630				
560	630	10	110	90	230	210	360	340	520	490	700				
630	710	20	130	110	260	240	400	380	570	540	780				
710	800	20	140	120	290	270	450	430	630	600	860				
800	900	20	160	140	320	300	500	480	700	670	960				
900	1000	20	170	150	350	330	550	530	770	740	1040				
1000	1120	20	180	160	380	360	600	580	850	820	1150				

Table 7.17b

Axial clearance of double row angular-contact ball bearings											
Bore diameter		Axial clearance									
d		C2		Normal		C3		C4			
over	to	min	max	min	max	min	max	min	max		
mm		µm									
6	10	1	11	5	21	12	28	25	45		
10	18	1	12	6	23	13	31	27	47		
18	24	2	14	7	25	16	34	28	48		
24	30	2	15	8	27	18	37	30	50		
30	40	2	16	9	29	21	40	33	54		
40	50	2	19	11	33	23	44	36	58		
50	65	3	22	13	36	26	48	40	63		
65	80	3	24	15	40	30	54	46	71		
80	100	3	26	18	46	35	63	-	-		
100	110	4	30	22	53	42	73	-	-		

Table 7.18

Radial clearance of double row self aligning ball bearings																					
Bore diameter		Cylindrical bore										Tapered bore									
d		C2		Normal		C3		C4		C5		C2		Normal		C3		C4		C5	
over	to	min	max	min	max	min	max	min	max	min	max	min	max	min	max	min	max	min	max	min	max
mm		µm																			
2,5	6	1	8	5	15	10	20	15	25	21	33	-	-	-	-	-	-	-	-	-	-
6	10	2	9	6	17	12	25	19	33	27	42	-	-	-	-	-	-	-	-	-	-
10	14	2	10	6	19	13	26	21	35	30	48	-	-	-	-	-	-	-	-	-	-
14	18	3	12	8	21	15	28	23	37	32	50	-	-	-	-	-	-	-	-	-	-
18	24	4	14	10	23	18	30	25	39	34	52	7	17	13	26	20	33	28	42	37	55
24	30	5	16	11	24	19	35	29	46	40	58	9	20	15	28	23	39	33	50	44	62
30	40	6	18	13	29	23	40	34	53	46	66	12	24	19	35	29	46	40	59	52	72
40	50	6	19	14	31	25	44	37	57	50	71	14	27	22	39	33	52	45	65	58	79
50	65	7	21	16	36	30	50	45	69	62	88	18	32	27	47	41	61	56	80	73	99
65	80	8	24	18	40	35	60	54	83	76	108	23	39	35	57	50	75	69	98	91	123
80	100	9	27	22	48	42	70	64	96	89	124	29	47	42	68	62	90	84	116	109	144
100	120	10	31	25	56	50	83	75	114	105	145	35	56	50	81	75	108	100	139	130	170
120	140	10	38	30	68	60	100	90	135	125	175	-	-	-	-	-	-	-	-	-	-
140	160	15	44	35	80	70	120	110	161	150	210	-	-	-	-	-	-	-	-	-	-

Table 7.19

Radial clearance of single row cylindrical roller bearings											
Bore diameter		Radial clearance									
d		C2		normal		C3		C4		C5	
over	to	min	max	min	max	min	max	min	max	min	max
mm		µm									
10	24	0	25	20	45	35	60	50	75	65	90
24	30	0	25	20	45	35	60	50	75	70	95
30	40	5	30	25	50	45	70	60	85	80	105
40	50	5	35	30	60	50	80	70	100	95	125
50	65	10	40	40	70	60	90	80	110	110	140
65	80	10	45	40	75	65	100	90	125	130	165
80	100	15	50	50	85	75	110	105	140	155	190
100	120	15	55	50	90	85	125	125	165	180	220
120	140	15	60	60	105	100	145	145	190	200	245
140	160	20	70	70	120	115	165	165	215	225	275
160	180	25	75	75	125	120	170	170	220	250	300
180	200	35	90	90	145	140	195	195	250	275	330
200	225	45	105	105	165	160	220	220	280	305	365
225	250	45	110	110	175	170	235	235	300	330	395
250	280	55	125	125	195	190	260	260	330	370	440
280	315	55	130	130	205	200	275	275	350	410	485
315	355	65	145	145	225	225	305	305	385	455	535
355	400	100	190	190	280	280	370	370	460	510	600
400	450	110	210	210	310	310	410	410	510	565	665
450	500	110	220	220	330	330	440	440	550	625	735
500	560	120	240	240	360	360	480	480	600	695	815
560	630	140	260	260	380	380	500	500	620	780	900
630	710	145	285	285	425	425	565	565	705	870	1010
710	800	150	310	310	470	470	630	630	790	980	1140
800	900	180	350	350	520	520	690	690	860	1100	1270
900	1000	200	390	390	580	580	770	770	960	1220	1410
1000	1120	220	430	430	640	640	850	850	1060	1360	1570
1120	1250	230	470	470	710	710	950	950	1190	1520	1760

Table 7.20

Radial clearance of double row cylindrical roller bearings with tapered bore					
Bearings with incommutable rings designed for work spindles of machine tools					
Bore diameter		Radial clearance			
d		C1NA		C2NA	
over	to	min	max	min	max
mm		µm			
24	30	15	25	25	35
30	40	15	25	25	40
40	50	17	30	30	45
50	65	20	35	35	50
65	80	25	40	40	60
80	100	35	55	45	70
100	120	40	60	50	80
120	140	45	70	60	90
140	160	50	75	65	100
160	180	55	85	75	110
180	200	60	90	80	120
200	225	60	95	90	135
225	250	65	100	100	150
250	280	75	110	110	165
280	315	80	120	120	180
315	355	90	135	135	200
355	400	100	150	150	225
400	450	110	170	170	255
450	500	120	190	190	285
500	560	130	210	210	315
560	630	140	230	230	345
630	710	160	260	260	390
710	800	180	290	290	435
800	900	200	320	320	480
900	1000	-	-	355	540

Table 7.21

Radial clearance of single row cageless needle roller bearings with interchangeable rings					
Bore diameter		Radial clearance			
d		normal		C2NA	
over	to	min	max	min	max
mm		µm			
10	14	10	50	25	70
14	18	15	55	35	75
18	24	25	65	40	80
24	30	30	65	50	80
30	40	40	75	60	95
40	50	40	85	65	100
50	65	45	90	70	120
65	80	50	110	75	135
80	100	60	115	95	150
100	120	70	125	115	70
120	140	80	155	130	205
140	160	80	160	140	210

Table 7.22

Radial clearance of double row spherical-roller bearings											
Bore diameter d		Cylindrical bore									
		C2		normal		C3		C4		C5	
over	to	min	max	min	max	min	max	min	max	min	max
mm		µm									
30	40	15	30	30	45	45	60	60	80	80	100
40	50	20	35	35	55	55	75	75	100	100	125
50	65	20	40	40	65	65	90	90	120	120	150
65	80	30	50	50	80	80	110	110	145	145	180
80	100	35	60	60	100	100	135	135	180	180	225
100	120	40	75	75	120	120	160	160	210	210	260
120	140	50	95	95	145	145	190	190	240	240	300
140	160	60	110	110	170	170	220	220	280	280	350
160	180	65	120	120	180	180	240	240	310	310	390
180	200	70	130	130	200	200	260	260	340	340	430
200	225	80	140	140	220	220	290	290	380	380	470
225	250	90	150	150	240	240	320	320	420	420	520
250	280	100	170	170	260	260	350	350	460	460	570
280	315	110	190	190	280	280	370	370	500	500	630
315	355	120	200	200	310	310	410	410	550	550	690
355	400	130	220	220	340	340	450	450	600	600	760
400	450	140	240	240	370	370	500	500	660	660	820
450	500	140	260	260	410	410	550	550	720	720	900
500	560	150	280	280	440	440	600	600	780	780	1000
560	630	170	310	310	480	480	650	650	850	850	1100
630	710	190	350	350	530	530	700	700	920	920	1190
710	800	210	390	390	580	580	770	770	1010	1010	1300
800	900	230	430	430	650	650	860	860	1120	1120	1440
900	1000	260	480	480	710	710	930	930	1220	1220	1570
1000	1120	290	530	530	780	780	1020	1020	1330	1330	1720

Table 7.23

Radial clearance of double row spherical-roller bearings											
Bore diameter d		Tapered bore									
		C2		normal		C3		C4		C5	
over	to	min	max	min	max	min	max	min	max	min	max
mm		µm									
30	40	25	35	35	50	50	65	65	85	85	105
40	50	30	45	45	60	60	80	80	100	100	130
50	65	40	55	55	75	75	95	95	120	120	160
65	80	50	70	70	95	95	120	120	150	150	200
80	100	55	80	80	110	110	140	140	180	180	230
100	120	65	100	100	135	135	170	170	220	220	280
120	140	80	120	120	160	160	200	200	260	260	330
140	160	90	130	130	180	180	230	230	300	300	380
160	180	100	140	140	200	200	260	260	340	340	430
180	200	110	160	160	220	220	290	290	370	370	470
200	225	120	180	180	250	250	320	320	410	410	520
225	250	140	200	200	270	270	350	350	450	450	570
250	280	150	220	220	300	300	390	390	490	490	620
280	315	170	240	240	330	330	430	430	540	540	680
315	355	190	270	270	360	360	470	470	590	590	740
355	400	210	300	300	400	400	520	520	650	650	820
400	450	230	330	330	440	440	570	570	720	720	910
450	500	260	370	370	490	490	630	630	790	790	1000
500	560	290	410	410	540	540	680	680	870	870	1100
560	630	320	460	460	600	600	760	760	980	980	1230
630	710	350	510	510	670	670	850	850	1090	1090	1360
710	800	390	570	570	750	750	960	960	1220	1220	1500
800	900	440	640	640	840	840	1070	1070	1370	1370	1690
900	1000	490	710	710	930	930	1190	1190	1520	1520	1860
1000	1120	530	770	770	1030	1030	1300	1300	1670	1670	2050

For double row ball bearings with angular contact, axial clearance measured at axial load of 100 N is stated instead of radial clearance.

If different clearance is selected than normal, one needs to process carefully and consider the effect if operating conditions at stabilised state. Radial clearance smaller than normal is selected quite rarely, e.g. in roller bearings for machine tool spindles. More often bearings with radial clearance bigger than normal are needed. This happens mostly in case the limit revolutions are exceeded, or in case of higher temperature gradient between the inner and outer ring and, finally, to increase axial load capacity of single row ball bearings. Axial load capacity of these bearings is increased at the clearance of C3 by approx. 10%, and at clearance C4 by approx. 20% in normal conditions.

It is understandable that not only too small but also too big radial clearance has negative effect on the operation and life service of roller bearing. As we know from experience, roller bearing is more negatively affected by small radial clearance than by big. If the thermal service conditions in the bearing are unclear, it is safer to select quite bigger radial clearance that might in an extreme case reduce the service life of the bearing which is insignificant.

Single row ball bearings with angular contact and single row tapered roller bearings are usually mounted in pairs in which radial or axial clearance or prestress are adjusted during the assembly. With advantage the property of the so-called combined bearings can be utilised in which the final axial clearance is set by the bearing manufacturer.

Dependence of radial and axial clearance in some bearing types is clear from chart 7.24.

Table 7.24

Dependence of radial clearance V_r , an axial clearance V_a	
Type of bearing	V_a/V_r
Single Row Ball Bearings	-
Double Row Angular Contact Ball Bearings, type 32, 33	1,4
Self-Aligning Ball Bearings	1,5/e
Tapered Roller Bearings	
Spherical Roller Bearings	

Figure 7.4 shows an informative graph of dependence of radial an axial clearance in bearing, applicable to single row ball bearings.

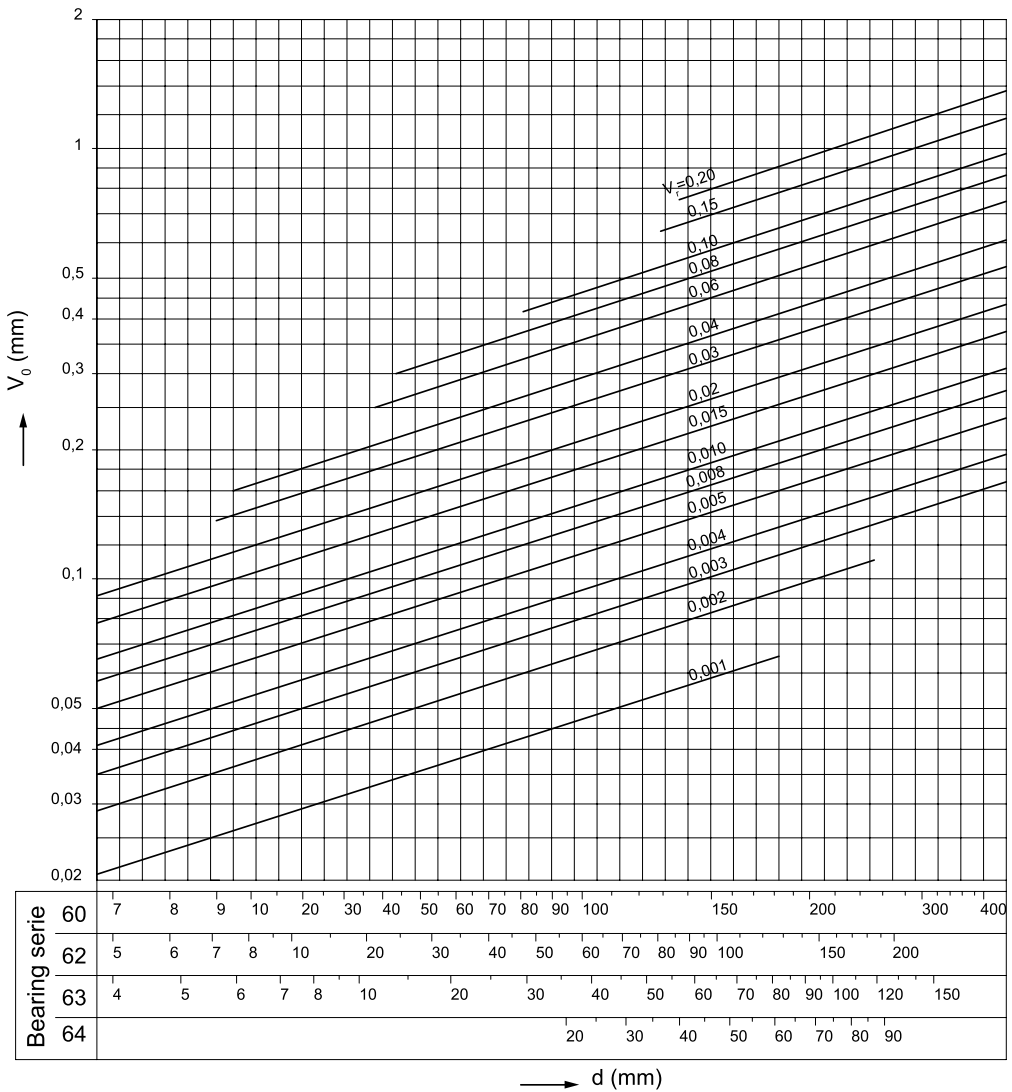

Fig. 7.4

7.3 Roller bearings materials

7.3.1 Materials of bearing rings and rolling bodies

In terms of materials used for production of roller bearings, durability and reliability of roller bearings is specifically increased by using more accurate metallurgical technologies based on recent surveys. Previous studies already demonstrated a direct connection between micropurity of the bearing steel used, and the occurrence of subsurface fatigue damage in the rolling contact. With regard to high pressures in the area of the rolling contact, strict requirements for micropurity and uniformity of distribution of carbidic phases are reasonable. The requirement of continuous durability increase can be satisfied by highly accurate and quality production combined with using materials with low content of oxygen and non-metal intrusions, and technologically correct thermal processing of rings and bearing rolling bodies when specified hardness, microstructure and dimensional stability is achieved. This provides resistance to wear and necessary load capacity of rolling contact. Chemical composition and maximum contents of undesired elements are defined in the international standard for bearing steels ISO 683-17.

For locations with a risk of damage in the area of rolling contact due to passage of electric current, bearings with ceramic insulation coating of the outer ring can be supplied.

If there are special requirements for material, design or use of bearings, information is available at the ZKL's technical and consultancy centre.

Semiproducts

Besides economic criteria, a semiproduct for production of roller bearings and rolling elements has to comply with technological requirements in terms of proper course of fibres and proper distribution of carbidic phases. For the economic reason and also due to convenient passage of fibres, the most convenient is using a tube semiproduct that is cold rolled to final shape prior to thermal processing. In this way, the majority of the bearing assortment with increased basic durability is produced with the identification "NEW FORCE".

Through-hardening steels

Majority of standard produced ZKL roller bearings are made of through-hardening steels designed for production of roller bearings. Those are carbon – chromium steels with an approximate content of 1% carbon and 1.5% chromium, complying with the international standard ISO 683-17 "Heat-treated steels, alloy steels and free-cutting steels, Part17: Steels for rolling bearings". After heat treatment, material has the same structure and hardness throughout the component section. After performed martensitic or bainite hardening and subsequent tempering, the hardness of final surfaces is 58 to 65 HRC.

Depending on the type, the highest service temperature of 120 °C to 200 °C is recommended for standard ZKL roller bearings. The maximum temperature for using the bearings depends on heat treatment of bearing components. For operation at temperatures to 250 °C, bearing components can stabilize in a special heat treatment process. In case of thermal stabilization for operation at higher temperatures, the hardness of components reduces significantly, and thus also the dynamic load capacity of the bearings. If long-term operation above 250 °C is required, we recommend bearings from high alloy steels designed for high temperatures.

Case hardening steels

After saturation with carbon and hardening, bearing components feature hard surface and simultaneously also tough core. They are used for production of bearings that are loadable with big strokes, locations with big overlap or alternatively for locations with a possibility of contaminated lubrication.

Corrosion-proof steels

These steels are used for bearings intended for operation in oxidizing environment, for instance for aviation technology or food processing industry.

Steels for high temperatures

These materials are used for bearings operating permanently at temperatures over 250 °C whilst maintaining hardness and standard service properties, e.g. in aircraft engines.

Steels for surface hardening

These steels offer convenient combination of hardened tough raceway with tough section core. They are used mainly in large bearings, or bearings with clamp flanges which are contained in bearing rings.

7.3.2 Materials for production of cages

Materials used for production of cages are selected with regard to the service temperature of the bearing, whether the bearing will operate in standard or vibrating environment, alternatively upon the requirements for chemical or corrosion resistance.

The basic quality of materials used for production of cages is good abrasion resistance and slip properties along with sufficient ductility.

Pressed steel cages

They are pressed from low carbon steels that ensure accuracy of final cage shape, as well as sufficient ductility. To improve slip properties and abrasion resistance, the surface of pressed cages is chemically and thermally treated. They suit typical temperature regimen of bearing operation up to 300 °C.

In smaller bearings sizes, pressed cages are even made of brass sheet.

Massive brass cages

They are made in routing from roughened or spun semiproducts. Service temperature should not exceed 250 °C.

Massive steel cages

In justified cases they are an alternative to brass massive cages. Service temperature may range up to 300 °C. The surface of the cage can be chemically and thermally treated.

7.3.3 Other materials

Polymers

Polymers, usually of polyamide 66 reinforced with glass fibres, are used mainly for production of cages and cage guide rings of double row spherical roller bearings of CJ design. Service operation of these components should not exceed 120 °C in the long term with the use of common lubricants, 150 °C in the short term (within 10 hours), and 170 °C in peaks (within 20 minutes). Usefulness of bearings with polyamide components at lower temperatures is, with regard to polyamide elasticity loss, up to the temperatures of -40 °C.

Ceramic materials

Are used mostly to prevent bearings from damage by passage of electric current, either in form of thermally layered coats on the surface of the outer or inner ring, alternatively by using rolling ceramic elements. Use of rolling elements from ceramic material is justified even in special high-revolution bearings.

Other

Materials of contact seals are selected so as their thermal and degradation resistance suited the selected use.

7.4 Cages

Cage has the below functions in a roller bearing: Distributes rolling bodies uniformly around the circumference and prevents their mutual contact which reduced friction in the bearing. It prevents slippage of rolling bodies in the bearing and falling rolling bodies out of separable bearings during their assembly.

In terms of design and materials, cages are divided in pressed (fig. 7.5) and massive (fig. 7.6).

Pressed cages are made mostly by pressing from steel or brass sheet, and usually are used in dimensionally smaller up to medium bearings. Comparing to massive cages, their advantage is lower weight.

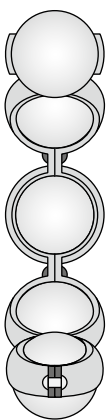

Fig. 7.5

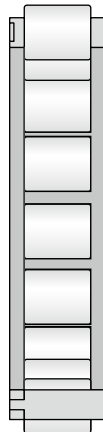
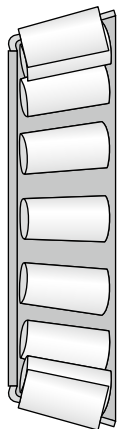
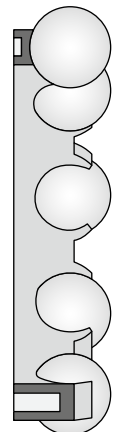
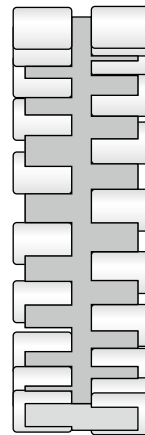

Fig. 7.6



Massive cages are made of steel, brass, bronze, light metals or plastics in various designs. Metal cage materials are used whenever increased requirements are imposed on the rigidity of the cage, and the bearing is designed for higher service temperatures. Cages in bearing run radially on rolling elements which is the most common way, or on flange of one of the bearing rings (fig. 7.7).

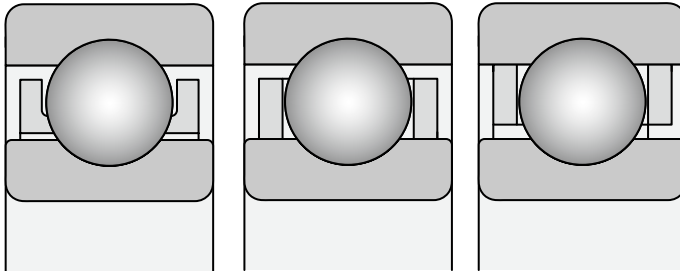

Fig. 7.7

Massive polymer cages are made by injection moulding. The injection moulding technology allows to production such cage shapes that enable designing bearings with high load capacity. Elasticity and low polyamide weight applies positively in shock stress of bearings, high acceleration and deceleration. Polyamide cages feature good slip properties. During lubrication of bearings with oil, the additives contained in the oil may affect negatively the service life of the cage.

Cages made of phenological resin are light but not suitable to high temperatures. They however feature good resistance to centrifugal forces. They are typically use in accurate ball bearings with angular contact.

Journal cages are made of steel; the condition is use of holy rolling bodies (fig. 7.8). Journal cages are used mainly in large bearings

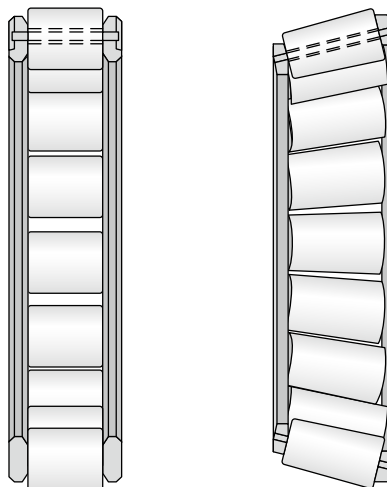

Fig. 7.8

Cageless bearings, i.e. fully complement, are used rarely – only in some types of bearings, e.g. single row cylindrical roller bearings.

In texts to individual design bearing groups the section dedicated to cages always states an overview of cages made in the general design, and delivery option of bearings with cages in different designs.

7.5 Shield and seals

Bearings with covers on one or both sides are made with shields (Z, ZZ, ZR, ZZR – fig. 7.9), or with contact seal ((RS, ZRS, RSR, ZRSR – fig. 7.10). Shields create contact-free sealing. In Z or ZZ version, the fitting for shield is on the inner ring; ZR or ZZR variants have shield adhered to the smooth flange of the inner ring.

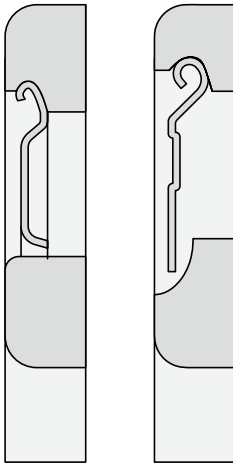

Fig. 7.9

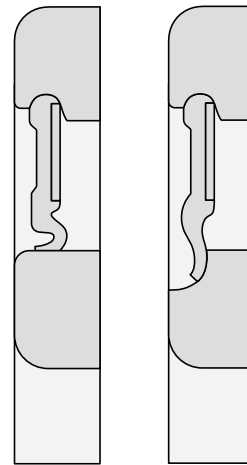

Fig. 7.10

The seal consists of sealing rings of nitrile rubber vulcanized on metal reinforcements that form an efficient contact seal in a design with rounded fitting on the inner ring (RS, ZRS), or in a design with contact on the smooth flange of the inner ring (RSR, ZRSR).

Shields and sealing rings are fastened in the outer ring recess, and are not detachable.

Bearings in basic design are filled with a quality plastic lubricant with temperature range between -30°C and $+100^{\circ}\text{C}$, in the short term even up to $+120^{\circ}\text{C}$. Filler of grease usually ensures greasing throughout the service life in normal service conditions. Bearings in this design cannot be additionally greased.

7.6 Designation of roller bearings

Bearing is designated by basic designation and extension expressing the difference between this bearing and the standard version bearing. Designation of bearings contains numerical and literal characters that determine the type, size and design of the bearing. Overview of symbols and their order is based on the scheme shown in figure 7.11.

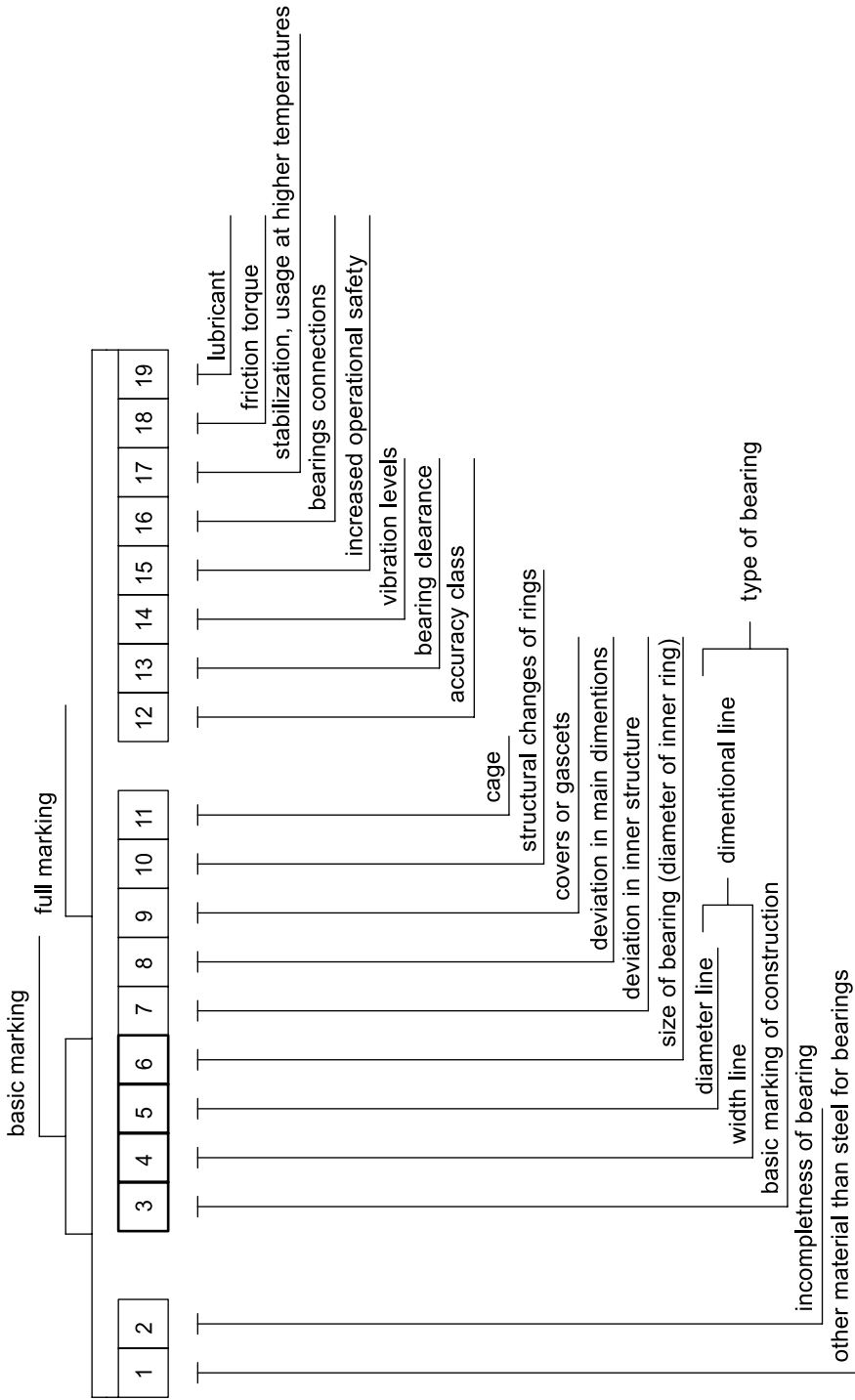

Fig. 7.11



7.6.1 Standard bearing version

In standard version, bearings are identified with basic designation consisting of the identification of the type and size of the bearing. The designation usually consists of a symbol expressing the design of the bearing (position 3 of the scheme), and a symbol for the dimensional group or diameter row (positions 4 and 5), e.g. type 223, 302, NJ22, 511, 62, 12 and so on. Designation of the bearing size contains characters for nominal bearing bore diameter d (position 6).

Bearings with bore diameter $d < 10$ mm:

Figures separate with fraction line or the last digit states directly the nominal bore dimension in mm, e.g. 619/2, 624.

Bearings with bore diameter $d = 10$ up to 17 mm:

double issue	00	identifies the bore	$d = 10$ mm, e.g.: 6200
	01		$d = 12$ mm, e.g.: 51101
	02		$d = 15$ mm, e.g.: 3202
	03		$d = 17$ mm, e.g.: 6303

Exception in designation are single row ball bearings of separable type E and BO where the double issue states directly the bore diameter in mm, e.g.: E17.

Bearings with bore diameter $d = 20$ mm up to 480 mm

Bore diameter is quintuple of the last double issue, e.g. bearing 1320 features bore diameter $d = 20 \times 5 = 100$ mm.

Exceptions are bearings with bore diameter $d = 22, 28$ and 32 mm where the double issue separated with fraction line stated directly the diameter of bore in mm, e.g. 320/32AX, and some bearing types, such as e.g. separable single row ball bearings of E type, and single row ball bearings of NG type where the double or triple issue states directly the bore diameter in mm, e.g.: E20, NG160.

Bearings with bore diameter $d > 500$ mm:

The last double issue or triple digit separated with fraction line states directly the bore dimension in mm, e.g. 30/530M, NU29/1060.

7.6.2 Full designation of bearings

Bearing produced in designs different from the standard are identified by the so-called designation, as is shown in the scheme in fig. 7.11. It consists of the basic designation and supplementary characters that express the difference from the basic version.

Meaning of supplementary characters

The following part states, in accordance with full designation, an overview and meaning of supplementary characters used. The digit in the bracket stated with individual groups corresponds with the position number in the scheme. The scheme also states positions in full designation of the bearing that us separated with a gap.

Other characters are written together without a gap. Characters for extension of designation that mean a digit are separated with a dash from the basic designation, e.g. 6305-ZZ.

The meaning of supplementary characters for design variances of different bearing types is described in relevant chapters of the chart section of the catalogue.

Supplementary characters before basic designation

Other material than common steel for roller bearings [1]

C rolling elements from ceramics – e.g. C B7006CTA

HSS high speed steel, e.g.: HSS 6215

X corrosion resistant steel, e.g.: X 623

T case hardening steel, e.g.: T 32240

Bearing incompleteness [2]

L separate detachable ring of separable bearing, e.g. L NU206, in thrust ball bearings without a shaft ring, e.g. L 51215

R separable bearing without detachable ring, e.g. R NU206 nebo R N310

E separate shaft ring or thrust ball bearing, e.g. E 51314

W separate body ring of thrust ball bearing, e.g. W 51414

K cage with rolling elements e.g.: K NU320

Supplementary characters behind the basic designation

Difference in inner design [7]

A single row angular-contact ball bearings with contact angle $\alpha = 25^\circ$, e.g. B7205ATB P5

. single row tapered bearings with higher load capacity and higher limit revolution frequency, e.g. 30206A

. thrust ball bearings with higher limit revolution frequency, e.g. 51,105A

AA single row angular-contact ball bearings with contact angle $\alpha = 26^\circ$, e.g. B7210AATB P5

B single row angular-contact ball bearings with contact angle $\alpha = 40^\circ$, e.g. 7304B

. single row tapered bearings with contact angle $\alpha > 17^\circ$, e.g. 32315B

BE single row angular-contact ball bearings with contact angle $\alpha = 40^\circ$, in new design, e.g. 7310BETNG



- C single row angular-contact ball bearings with contact angle $\alpha = 15^\circ$, e.g. 7220CTB P4
- double row spherical roller bearings in new design, e.g. 22216C
- CA single row angular-contact ball bearings with contact angle $\alpha = 12^\circ$, e.g. B7202CATB P5
- CB single row angular-contact ball bearings with contact angle $\alpha = 10^\circ$, e.g. B7206CBTB P4
- D single row ball bearing of type 160 with higher load capacity, e.g. 16004D
- E single row cylindrical roller bearings with higher load capacity, e.g. NU209E
- double row spherical roller bearings with higher load capacity, e.g. 22215E
- Spherical roller thrust bearings with higher load capacity, e.g. 29416E

Difference in main dimensions (8)

- X Change in main dimensions, established by new international standards, e.g. 3202BAX

Covers (9)

- RS seal on one side, e.g. 6304-RS
- 2RS seal on both sides, e.g. 6204-2RS
- RSN seal on one side and snap ring groove on the outer ring on the opposite side than the seal, e.g. 6306RSN
- RSNB seal on one side and snap ring groove on the outer ring on the same side as the seal, e.g. 6210RSNB
- 2RSN seal on both sides and snap ring groove on the outer ring, e.g. 6310-2RSN
- RSR seal on one side, adhering to the smooth inner ring collar, e.g. 624RSR
- 2RSR 2RSR – seals on both sides adhering to the smooth inner ring collar, e.g. 608-2RSR
- Z shield on one side, e.g. 6206-Z
- ZZ shields on both sides, e.g. 6304-ZZ
- ZN shield on one side and snap ring groove on the outer ring on the opposite side than the shield, e.g. 6208ZN
- ZNB shield on one side and snap ring groove on the outer ring on the same side as the shield, e.g. 6306ZNB
- ZZN shields on both sides and snap ring groove on the outer ring, e.g. 6208-ZZN

ZR shield on one side, adhering to the smooth inner ring flange, e.g. 608ZR

ZZR shields on both sides, adhering to the smooth inner ring flanges, e.g. 608-ZZR

Design change of bearing rings [10]

K Tapered bore, taper ratio 1:12, e.g. 1207K

K30 Tapered bore, taper ratio 1:30, e.g. 24064K30M

N snap ring groove on the outer ring, e.g. 6308N

NR snap ring groove on the outer ring, and inserted snap ring, e.g. 6310NR

NX snap ring groove on the outer ring, dimensions of which do not comply with ČSN 02 4605, e.g. 6210NX

D split inner ring, e.g. 3309D

W33 groove and lubrication bores on the outer ring circumference, e.g. 23148W33M

O lubrication slots on outer ring fillet of the bearing , e.g. NU1014O

Cage [11]

Material of cages for standard design bearings is usually not specified.

J cage pressed from steel plate, guided on rolling elements e.g.: 6034J

J2 cage pressed from steel plate, guided on rolling elements. New design of single row tapered bearings, e.g. 30206AJ2

Y cage pressed from brass sheet, guided on rolling elements e.g.: 6001Y

F massive steel cage, guided on rolling elements e.g.: 6418F

L massive light metal cage, guided on rolling elements e.g.: NG180L C3S0

M massive brass or bronze cage, guided on rolling elements e.g.: NU330M

T massive textite cage, guided on rolling elements e.g.: 6005T

TN massive cage of polyamide or similar plastic, guided on rolling elements e.g.: 6207TN

TNG massive cage of polyamide or similar plastic, reinforced by glass fibres, guided on rolling elements e.g.: 2305TNG



Cage design (stated characters are always used in combination with cage material characters).

- A cage guided on outer ring, e.g. NU226MA
- B cage guided on inner ring, e.g. B7204CATB P5
- P massive window cage, e.g.: NU1060MAP
- H open single-piece cage, e.g.: 629TNH
- S cage with lubrication slots, e.g.: NJ418MAS
- R silver-plated cage, e.g.: 6210MAR
- V bearing without cage with full number of rolling elements, e.g. NU209V

Accuracy level (12)

- P0 normal accuracy level (is not designated), e.g. 6204
- P6 higher accuracy level than normal, e.g. 6322 P6
- P5 higher accuracy level than P6, e.g. 6201 P5
- P5A higher accuracy level than P5 in some parameters, e.g. 6006TB P5A
- P4 higher accuracy level than P5, e.g. B7204CBTB P4
- P4A higher accuracy level than P4 in some parameters, e.g. B7205CATB P4A
- P2 higher accuracy level than P4, e.g. B7200CBTB P2
- P6E higher accuracy level for rotary electrical machines, e.g. 6204 P6E
- P6X higher accuracy level for single row tapered bearings, e.g. 30210A P6X
- SP higher accuracy level for roller bearings with tapered bore, e.g. NN3022K SPC2NA
- UP higher accuracy level such as SP for roller bearings with tapered bore, e.g. N1016K
UPC1NA

Clearance (13)

- C2 smaller clearance than normal, e.g. 608 C2
- normal clearance (is not designated), e.g. 6204
- C3 bigger clearance than normal, e.g. 6310 C3
- C4 bigger clearance than C3, e.g. NU320M C4

C5 bigger clearance than C4, e.g. 22330M C5

NA radial clearance in bearings with incommutable rings (is indicated always behind the radial clearance group), e.g. NU215 P63NA

R... radial clearance in non-standardised range (range in μm) , e.g. 6210 R10-20

A... axial clearance in non-standardised range (range in μm) , e.g. 3210 A20-30

Noise level [14]

C6 reduced noise level lower than normal (is not designated), e.g. 6304 C6

C06 reduced noise level lower than C6, e.g. 6205 C06

C66 reduced noise level lower than C06, e.g. 6205 C66

Specific values for C06 and C66 are determined based on an agreement between customer and supplier.

Note: Bearings in accuracy level P5 and higher feature noise level within C6.

Increased operational safety [15]

C7, C8, C9 bearings with increased operational safety designed mainly for use in aviation industry, e.g. 6008MB P68

Combining characters [12-15]

Characters/symbols of accuracy level, clearance in bearing, noise levels and increased operational safety are combined with simultaneous omission of C character and following special property of bearings, e.g.

P6 + C3 = P63 e.g. 6211 P63

P6 + C8 = P68 e.g. 16002 P68

C3 + C6 = C36 e.g. 6303-2RS C36

P5 + C3 + C9 = P539 e.g. 6205MA P539

P6 + C2NA + C6 = P626NA e.g. NU1038 P626NA

Bearing association [16]

Designation of associated pair, triplet or quaternion of bearings consists of characters expressing arrangement of bearings and of characters defining the inner clearance or prestress of associated bearings.

Apart from characters stated in the chart the U character is used to identify that relevant bearings can be associate universally, example of designation B7003CTA P4UL.

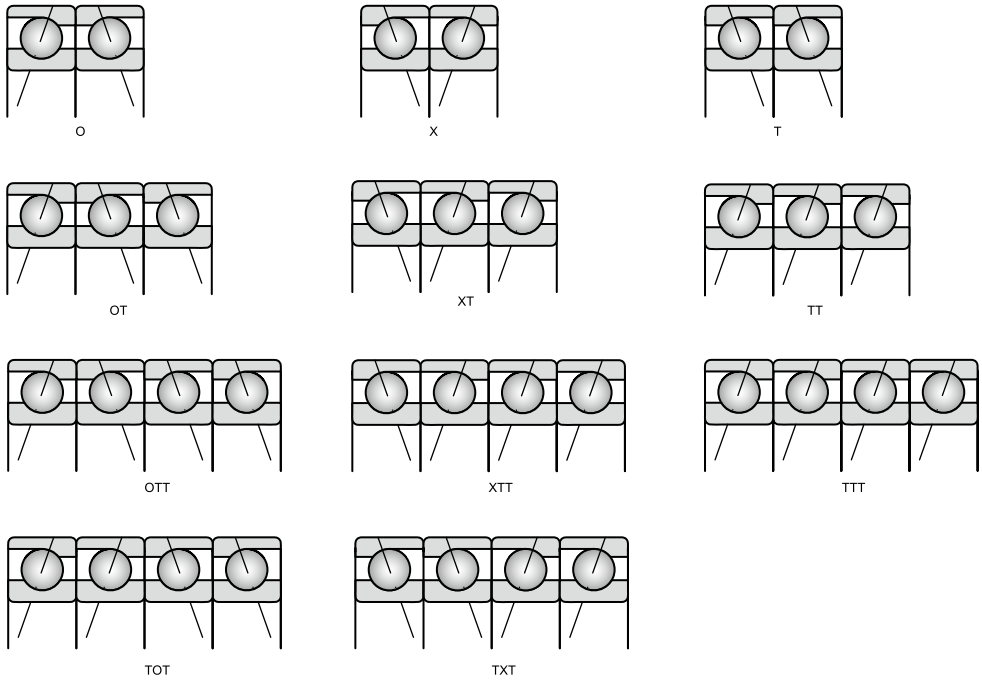

Fig. 7.12

Inner clearance or prestress

Stated characters are always used in combination with association characters.

A Association of bearings with clearances, e.g. 73050A

O Association of bearings without clearances, e.g. 7305 P6X0

L Association of bearings with small prestress, e.g. B7205CATB P4UL

M Association of bearings with medium prestress, e.g. B7204CATB P5XM

S Association of bearings with big prestress, e.g. B7304AATB P40S

Stabilisation for operation at higher temperature [17]

Both rings have stabilised dimensions for operation at higher temperature.

S0 – for service temperature up to 150 °C

S1 up to 200 °C

S2 up to 250 °C



S3 up to 300 °C

S4 up to 350 °C

S5 up to 400 °C

Example of designation NG160LB C4S3

Friction torque [18]

JU reduced friction torque, e.g. 619/2 JU

JUA bearings with defined friction torque at start-up 632 JUA

JUB bearings with defined friction torque at after-running, e.g. 623 JUB

Grease [19]

For bearings with shield or seal on both sides, the plastic lubrication other than common is designated by means additional characters. The first two characters define the range of service temperature, and the third character (letter) defines the name or type of lubricant according to the manufacturer's specification, or another character (digit) defines the amount of grease that fills the covered space of the bearing.

TL grease for low service temperatures from -60 °C to +100 °C

..... example of designation 6302 2RSTL

TM grease for medium service temperatures from -35 °C to +140 °C

..... example of designation 6204 2ZRTM

TH grease for high service temperatures from -30 °C to +200 °C

..... example of designation 6202 2ZTH

TW grease for both low and high service temperatures from -40 °C to +150 °C

..... example of designation 6310 2ZC4TW

Note: The TM marking need not be stated on bearings and packing.

Bearings by special technical conditions

Single purpose bearings dimensions of which comply with the dimensional plan but the list of all characters of extension expressing their technical characteristics would cause confusion of marking, can be upon agreement between manufacturer and customer replaced with basic designation, attaching the TPF or TPFK marking and a two- or three-digit number behind the basic designation of the bearing, which defines the number of the agreed technical specification determining all technical parameters of bearings.

TPF bearings made by special technical conditions agreed with customer,
e.g. bearing 6205MA P66 by technical terms TPF 11142-71 is designated as follows:
6205MA P66 TPF 142.

TPFK bearings by special technical terms agreed with customer which have high number of characters stating changes against the basic version. In this case, basic characters are replaced with designation TPFK containing relevant number of technical terms, e.g. bearing NU1015 made by technical terms. TPFK 11137-70 is designated as NU1015 TPFK137.

Bearings by special drawing documentation PLC

Bearings which by some of their dimension do not comply with the dimensional plan or are in line with the next development are marked with PLC by their manufacturer, as well as with other numerical characters. Usually they are single purpose bearings for one customer or a certain application method.

PLC ABC-DE.F (designation structure until 2012)

PLC identification of special roller bearing

A design assembly

0 single row ball bearings

1 double row ball bearings:

2 thrust ball bearings

3 Not completed.

4 single row cylindrical roller, spherical-roller and needle roller bearings

5 double and multirow cylindrical roller, spherical-roller and needle roller bearings

6 single row, double row and four row tapered roller bearings

7 special double row bearings

8 assembly units and separate parts

9 thrust cylindrical roller, spherical roller, tapered roller and needle roller bearings

BC dimensional assembly – two digit characters

DE ordinal number within dimensional assembly – two digit characters

F difference in design - one digit or combination of numerical character and letter

Due to extending the assortment of special bearings, it was decided in 2013 to change the structure of designating special bearings: Upon the establishing of a new system, the designation on already produced bearings will not be changed.

PLC AB-CD-EFG (designation structure since 2013)

PLC identification of special roller bearing

A design assembly

- 1 ball bearings
- 2 thrust ball bearings
- 3 cylindrical roller bearings
- 4 thrust cylindrical roller bearings
- 5 needle roller bearings
- 6 spherical-roller bearings
- 7 spherical roller thrust bearings
- 8 tapered roller bearings
- 9 thrust tapered roller bearings
- 0 other bearings and mounting assemblies
- B number of rolling units or bearings in mounting assemblies
- CD dimensional assembly – two digit characters
- EF ordinal number within dimensional assembly – two digit characters
- G difference in design - one digit or combination of numerical character and letter

7.7 NEW FORCE bearings

In order to satisfy the needs of technically advanced customers, ZKL pays particular attention to technical development of products and investments in new technologies. The outcome of one of the recent key innovations is initiation of successive start up of production of ZKL bearings with higher quality standard with designation NEW FORCE.

The NEW FORCE bearings represent a new generation of ZKL bearings. Launching of bearings brings customers higher durability of bearings, enhanced operational safety, prolonged maintenance intervals and thus substantial reduction of operating costs. NEW FORCE bearings are designed for extreme locations of transmissions, railway vehicles, presses, rolling mills, paper machines, pumps, machine tools, power engineering plants, polygraphic machines, etc.

As the first integrated new generation bearings, the radial spherical-roller bearings were launched on the market, double row self-aligning ball bearings, double row angular-contact ball bearings and thrust ball bearings. The next phase of launching bearings of this standard was the production assortment of bearings with outer diameter over 400 mm.

The achieved parameters of NEW FORCE bearings are the result of ZKL development in the following areas:

- Material of roller bearing components
- Technology of bearing ring flaring
- Optimisation of inner construction
- Surface treatments of bearing components

The achieved results allowed ZKL to offer NEW FORCE roller bearings with high utility properties to their customers:

- high dynamic load capacity
- low friction
- reliability in the extreme operating conditions

High durability of bearings

Increase of dynamic load capacity by 8% to 25% brings increase of durability of bearings by 30% up to 110%, comparing to the up-to-now designs.

Increase of dynamic load capacity allows customer to design construction with smaller dimensions to transfer the same load. Thus ZKL brings to their customer an opportunity to reduce total price of the equipment, and achieve power savings during operation.

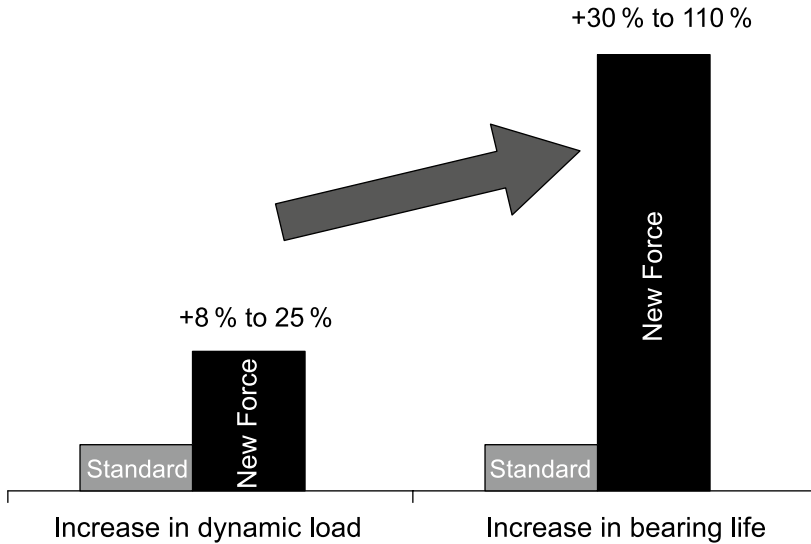

Fig. 7.13

Use of quality bearing material

Steels for production of bearings meet the parameters of international standards defined by ISO 683-17. Production of bearing rings and rolling elements utilised high quality material of selected smelting houses. Long-term cooperation with suppliers ensures continuous process of improving parameters of input material.

Key quality parameters of steel and its processing affect the service properties of bearing, i.e. resistance to fatigue damage, abrasion resistance and dimensional stability. These are:

- chemical composition and heat treatment**

Selection of the type of bearing steel and optimisation of heat treatment conditions is conducted by the dimension of the component. The heat treatment processing technology of NEW FORCE bearings ensures stable hardness values of bearing components in the entire section. Spherical-roller bearing components are heat treated to ideal material structure and hardness that enable using of the bearings at service temperatures to 200 °C. The final material structure ensures dimensional stability of bearing components throughout their service life.

- Content of non-metal intrusions – micropurity**

Reduction of content of non-metal intrusions is the key quality parameter in the bearing steel metallurgy development. In production of bearings, ZKL utilises bearing steel with minimum oxygen content.

- Type of semiproduct**

The quality of bearing and production economics are affected also by selection of the semiproduct type. The level of forming and positive angle of forming fibre contact towards the orbit are the parameters that positively increase resistance of the NEW FORCE bearings against fatigue damage,

Technology of bearing ring rolling

Basic research demonstrated effect of material fibre direction towards the contact surface to the durability of bearings. Most convenient is such layout of fibres when their direction is in parallel with the contact surface. With increasing fibre direction angle towards the contact surface the durability decreases. The technology of cold or semi-heating rolling brought an ideal material structure of the NEW FORCE bearings in order to achieve higher durability of bearings.

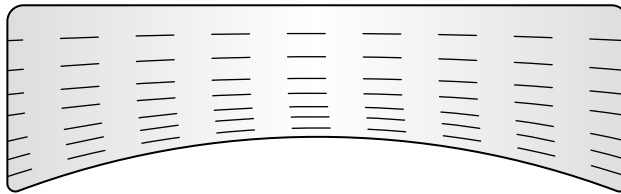

Threads 1 - after rolling (outer ring)

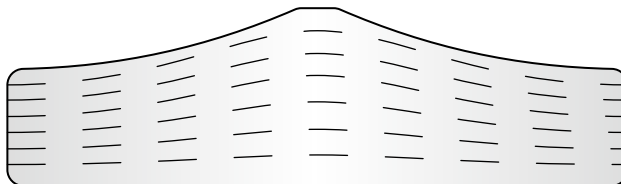

Threads 2 - after rolling (inner ring)

Fig. 7.14

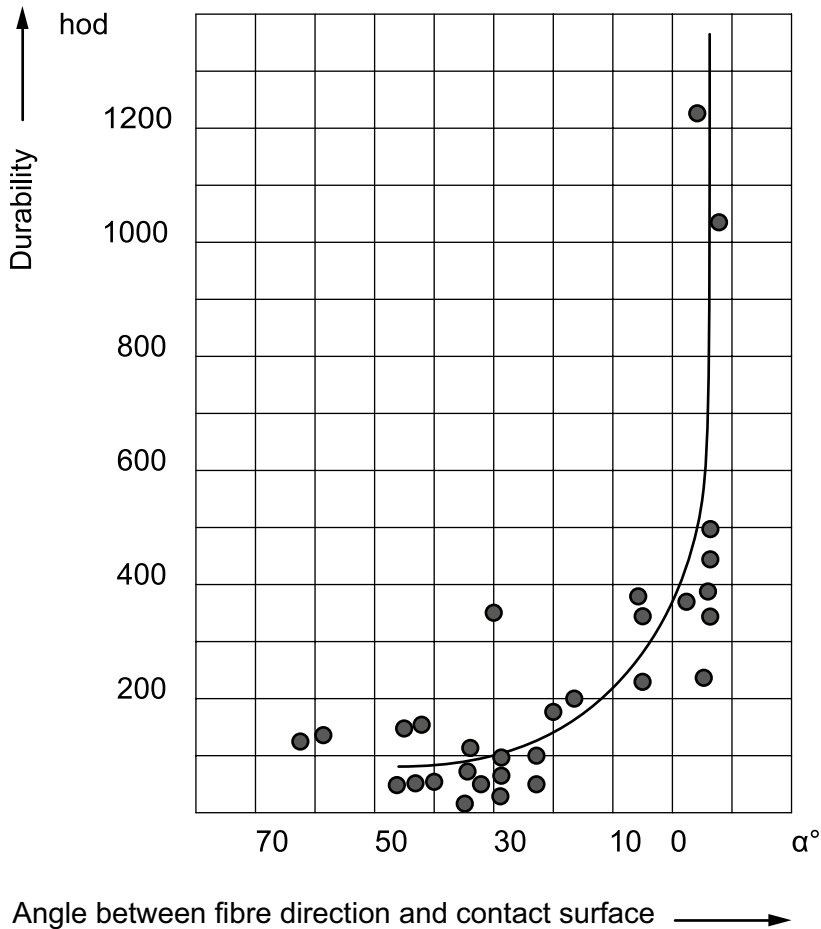

Fig. 7.15

Optimised design and inner geometry

Advanced design and calculation programs, together with new bearing production technologies, enabled optimisation of inner construction of bearings and improved accuracy of functional areas. Thus the NEW FORCE version bearings achieved better quality of functional surfaces and improved course of discharge voltages in bearing component sections, comparing to the standard bearing designs. This brings reduced noise level and higher accuracy of bearing run, as well as extended durability of bearings.

Special surface treatment

Within innovation programs, a new design of sheet cages for radial and thrust spherical-roller bearings was launched in the production. Cages are made of steel plate with surface treatment in order to improve slip properties and reduce wear of cages. The design of cages allows achieving better lubrication and extended service life of bearings. Surface treatments of bearing components represent a well tested way of improving bearing properties for certain locations. The benefit of surface layers lies in better keeping the lubricant in the rolling contact, reduced friction and enhanced resistance to wear and corrosion. We recommend that suitability of surface treatment for special operating condition is discussed with the technical and consultancy services of ZKL.



Bearings NEW FORCE +

ZKL bearings with NEW FORCE+ marking represent a brand new generation of ZKL bearings which is characterised by an innovated modification of the bearing inner structure geometry towards optimum voltage course in the area of rolling contact. This ZKL bearings' innovation is associated with further enhancement of accuracy, comparing to the standardly produced bearing assortment, including the NEW FORCE bearings.

Optimisation of the shape of rolling surfaces brings improved dynamic load capacity of bearings and thus also significant extension of bearings' durability. Development of the NEW FORCE+ generation is associated with the introduction of new calculation methods in the structure of bearings based on FEM and production upgrade by introducing numerically controlled machines that enable achieving final shapes of functional surfaces with modified geometry.

With regard to the fact that the entire design optimisation and production process of modified parts is unique for every bearing application, the NEW FORCE+ bearing generation is not designed to be launched in the standard production program of ZKL. The bearings will be manufactured upon request for extreme locations for selected OEM customers.

7.8 Technical support

ZKL operates as bearing manufacturer and supplier already since 1947. Since the beginning, the company has been cooperating with their customers worldwide. This allows continuous expansion of the ZKL rolling bearing production assortment offered in maximum quality at reasonable price. Experience in operation of bearings obtained in cooperation with customers, along with continuous education of their employees allows ongoing development of technical support to ZKL customers and extension of services for ZKL bearing users.

Proposal verification

The ZKL bearings' structure and their basic parameters are designed by the ZKL's own well tested methodologies that adhere to the international ISO standards. Designing new bearings utilises most sophisticated design and calculation CAD systems. Designs of new bearings are optimised and their rigidity checked by means of FEM based numerical calculations. When creating designs, information obtained in achieved test results and experiences from production and operation of ZKL bearings are utilised.

Verification of quality parameters of ZKL bearings

Parameters of ZKL rolling bearings are verified in tests within development, as well as in periodical quality assessment during series production. Tests are conducted according to the company's own methods in the test stations of the bearing test room. Bearing and input material tests results are analysed and serve as the basis for new design, technological and investment solutions.

Technical support for ZKL bearing users

Customer needs are solved by fully available workers of ZKL technical and consultancy services. Expert workers are ready to solve operatively requests and questions of ZKL bearing users in the area of selection of bearings, design of rolling location and assembly procedures. ZKL technical support provides users with information in the area of roller bearings, accessories and tribology. Upon user's request it also provides professional supervision over assembly and disassembly of bearings directly at customer, and organizes professional training course of user employees. It cooperates with manufacturers in development of rolling location. It draws up expert opinions on broken bearings. It determines causes of accidents and proposes measures to prevent them.



8. Bearing applications

8.1 Arrangement of bearings

To locate rotary shaft you need at least two bearings that are located in certain distance from each other. Depending on the application method, location with axially free and axially guiding bearing is selected; prestressed location or floating arrangement of bearings. See figure 4.12 in chapter Bearing type selection for examples of bearing arrangements.

8.1.1 Location with axially free and axially guiding bearing

Axially guiding bearing on one shaft end brings besides radial load element also axial element in both directions. For the above reason, it has to be secured both in the shaft and in the body. Axially free bearing in location compensates production inaccuracies in location and, first of all, changes in dimensions in operation due to increased temperatures. An ideal axially free bearing is roller bearing in N and NU design the rolling bodies of which can move on the raceway of bearing ring without guide flanges. Bearings of the other types, such as ball bearings and spherical-roller bearings, can be used as axially free only if one of bearing races is push-located.

Axially guide bearing guides shaft in axial direction and besides radial forces captures also axial forces. Selection of bearing type to be used as axially guide bearing depends on the size of axial load and on requirements for accuracy of shaft location. Double row angular-contact ball bearing ensures more accurate axial guidance than e.g. ball or spherical-roller bearing. Accurate axial guidance can be achieved also by a pair of tapered roller bearings which are used as axially guide bearing. At lower axial load even NUP cylindrical roller bearing can be used as axially guide bearing.

8.1.2 Symmetrical arrangement of bearings

This type of location suits mainly short shafts. It features shaft being guided in one direction by one bearing and in other direction by other bearing. Suitable bearings for this type of arrangement are all radial bearings that allow transfer of axial force at least in one direction. In this arrangement, prestressed bearings can be mounted (fig. 8.1).

8.1.3 Prestressed location

Location of prestressed bearing usually consists of symmetrically placed ball bearings with angular contact, or of tapered roller bearings. Prestress is achieved by use of springs. Such design compensates thermal dilatation. It is used in case when idle bearings can be exposed to vibrations. Prestressed bearings can reduce noise level, especially in small electric motors.

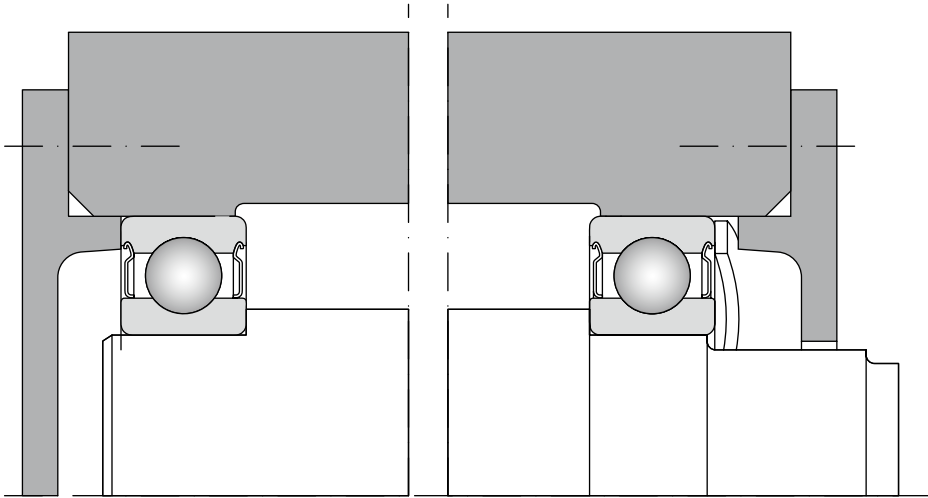

Fig. 8.1

Spring acts on outer race of one of the bearings whilst relevant outer race has to allow axial displacement in the body. Prestress remains practically constant even though the bearing axially moves due to thermal dilatation. Required prestress can be calculated using the below relation:

$$F = k \cdot d$$

F Prestress force [kN]

k coefficient, see next

d bearing hole diameter [mm]

Depending on design of electric motor, the coefficient may reach values of 0.005 up to 0.01.

If prestress is supposed to prevent bearing from getting damaged due to vibrations, it has to be set to higher level.

Then $k = 0.02$ has to be selected.

This method is however not suitable for locations that must feature high rigidity where the direction of acting load changes, or where shock load acts.

If certain optimum prestress value is exceeded, rigidity increases only insignificantly whilst friction and also service temperature in the bearing grow rapidly. This reduces durability of bearing since additional constant load acts on it. Informative relation between durability and prestress – clearance – is indicated in diagram in fig. 8.2.

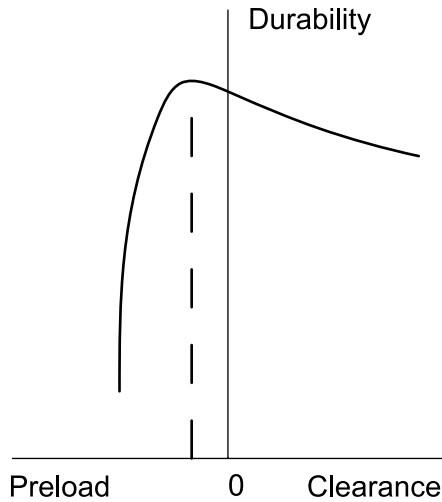

Fig. 8.2

8.2 Location design – General principles

Properties of bearings are fully utilised only when bearing races are supported along the entire circumference and width of raceways. Solid support surface can be of either cylindrical or tapered shape, in thrust bearings the surface is flat. Support surfaces must be manufactured to have adequate accuracy, and must not be provided with grooves, holes, etc. Besides that, bearing races must be reliably secured to prevent them from turning in the body or on the shaft.

Suitable radial security and adequate support can only be achieved if bearing rings are mounted with overlap. If however easy assembly and disassembly are required, alternatively axial transferability of axially free bearing, fixed location of the ring cannot be selected.

Where free location is chose, provisions must be adopted to avoid irrevocable wear during shifting the ring.

Rotating shaft or another component located in roller bearings is guided by them in radial and axial direction so that the principal condition of definiteness of its movement is achieved. If possible, the component should certainly be located, i.e. supported radially on two spots and axially in one spot.

Examples of such location are shown in figures 4.12. Most common location is such where the shaft is located radially in two bearings one of which locks it in axial direction. Guide (fixed) bearing transfers radial load and also axial load in both directions. Radial bearings are mostly used as guide. They are able to transfer combined load, e.g. single row ball bearings, double row angular-contact bearings, double row self-aligning ball bearing, double row spherical-roller bearings or single row angular-contact ball bearings and tapered roller bearings. The lastly mentioned two bearing types must be assembled in pairs. Free bearing only transfers radial load and must allow certain displacement of the shaft in axial direction in order to prevent occurrence of undesired prestress caused by external effects (thermal dilatation, production inaccuracy of connecting location components, etc.).

Axial displacement can be achieved by shifting between one of the body rings and machine components directly associated with the bearing, e.g. between the outer bearing ring and the bore in the body (fig. 4.12a, b), or directly in the bearing (fig. 4.12 c to h).

Locations where higher radial force and axial load in higher revolution frequency act should be solved by the bearings capturing only radial or axial forces, see fig. 8.3.

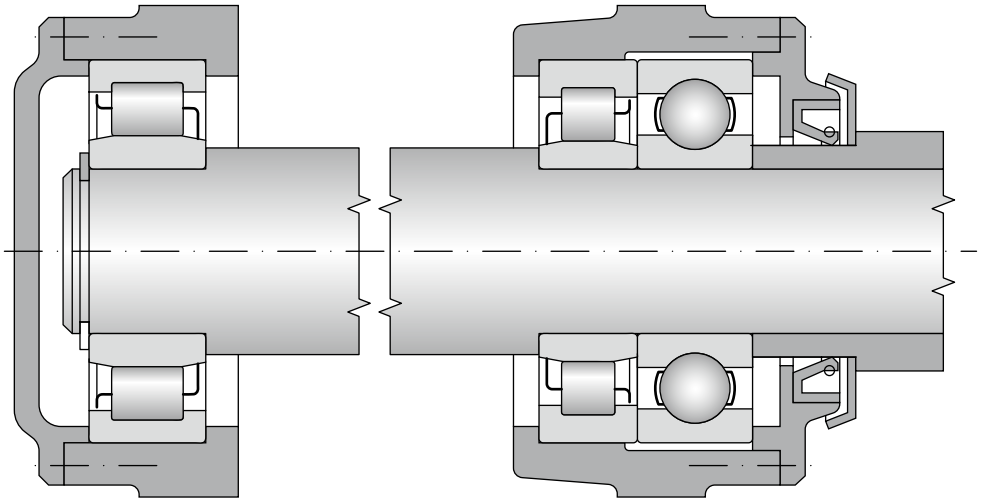

Fig. 8.3

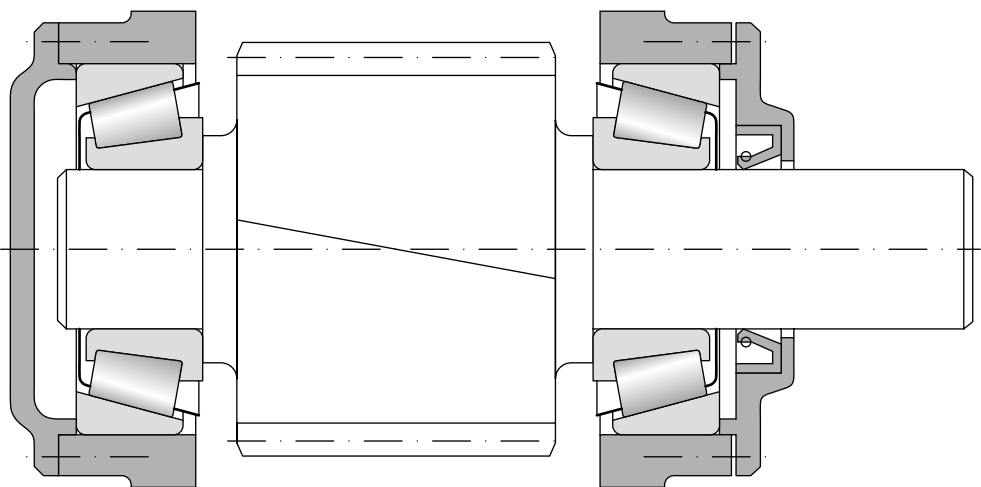

Fig. 8.4

In these cases, any of radial bearings can be used for radial guidance, and those radial bearings for axial guidance that feature the ability to transfer also axial load, alternatively a pair of these bearings or double direction thrust bearings or a pair of single direction thrust bearings. Condition is that axially guide bearings have to be located with radial clearance.

Another frequently used solution is location in two bearings the design of which allows capturing of both radial and axial load in both directions. Axial load is captured in turns by both bearings, always by the direction in which forces act and, at the same time, they transfer also radial load. An example of such location is shown in figure 8.4.

In this case, a pair of single row tapered roller or single row angular-contact ball bearings is used as a well tested construction. Also other types of bearings that are able to transfer load in radial and axial direction at the same time can be used, e.g. single row bearings, alternatively single row cylindrical roller bearings in NJ design, etc.

Radial and axial security of bearing on journal and in body bore or in another part has direct connection with the overall design location arrangement. When selecting the method of fixation, the character and intensity of acting forces has to be considered particularly, as well as service temperature at the point of location and the material of connecting components.

When specifying the dimensions of connecting parts, the designer needs to consider also the assembly and disassembly method and maintenance actions, besides the type and dimensions of the bearing.

8.2.1 Radial security of bearings

Bearing is fixed in radial direction on fitted cylindrical surface on the surface of the journal and bore in the body. In some cases of fixation on journal, adapter or withdrawal sleeve is used; alternatively the bearing can be fixed directly on tapered journal.

Proper radial fixation of bearing on journal and in body is very important for utilisation of its loading capacity and correct location function. In doing so, the following aspects need to be considered:

- a) safe fixation and uniform support of rings
- b) easy assembly and disassembly
- c) displacement of free bearing in axial direction

In principle, both bearing rings should be fixed firmly since only this way their reliable support on the entire circumference and radial fixation against spinning can be achieved. To simplify assembly and disassembly or in order to shift free bearing, one of the rings can be located as sliding.

If proper radial fixation of bearing is selected, one needs to evaluate and consider the effect of the method of rotation and intensity of load.

Circumferential load

Circumferential load occurs when relevant bearing ring turns, and the direction of load does not change, or when the ring does not turn and the load rotates. The bearing ring circumference is loaded successively in one revolution. In this case, loaded ring must be always fixed with necessary overlap.

Spot load

Spot load occurs when the bearing ring stands and outer force is directed still in the same spot of the raceway, or when the ring and force rotate at the same revolution frequency. The ring to which the spot load acts can be located with clearance (mobile), if the conditions require so.

Uncertain way of loading

In case of uncertain way of loading, the ring is acted on by variable external forces the direction and change of load of which cannot be determined (e.g. unbalanced masses, shocks, etc.). Uncertain way of loading requires that both rings are located with overlap (firmly). Under this condition in majority cases of location bearings with increased radial clearance have to be selected.

Load intensity

The load directly affects selection of the size of overlap in location. The bigger the load of the bearing, the bigger overlap in location has to be selected. This particularly applies in cases of shock and vibration load of the bearing. Fixed location on journal or in bore of the body induces deformation of ring, which reduces radial clearance. To ensure the needed radial clearance in cases of fixed location, sometimes bearings with increased radial clearance have to be used. Final clearance after assembly depends on the type and size of the bearing. Therefore the size of needed overlap of fitted ring has to be considered by the type and size of the bearing. For bearings of smaller dimensions smaller overlaps are selected, and vice versa. Relatively smaller overlaps are used e.g. for ball bearings of the same bigness comparing to cylindrical roller, tapered roller or spherical roller bearings.

Material and design of connecting pieces

Designing and determination of tolerances of connecting parts must take into account the materials used, as well as the construction of the connecting pieces. Results of practical experiences reflect in the below stated charts. When bearings are mounted in bodies made of light metal alloys or on journals of hollow shafts, location with higher overlaps has to be selected.

Split bodies are not suitable for locations with big overlaps since they represent a risk of gripping the bearing in the dividing plane of the body.

Heating and warmth

Warmth generated in bearing may lead to release of overlap on the journal which may cause spinning the ring. An opposite case may occur in the body. Heating causes clearance adjustment which will limit up to eliminate axial displacement of the ring of free bearing in the body. Therefore we need to be very attentive to this factor when designing the location.

Accuracy of bearing surfaces

Accuracy of bearing surfaces in terms of tolerances and geometrical shapes is important since it may transfer to raceways of bearing rings. First of all, this has to be reflected in location designs which are highly focused on the running accuracy. Major share of inequality is transferred in thin profiles of bearing rings.

When normal accuracy level bearings are used, usually tolerances within the tolerance level IT6 are selected for the bearing surface on the journal, whilst for the bearing surface in the body the selected tolerance level is IT7.

For ball and cylindrical roller bearings of smaller dimensions, IT5 level can be used for the journal and IT6 for the bore in the body.

For bearings of higher accuracy levels, for locations with high accuracy requirements, e.g. machine tool spindles, the recommended least level is IT5 for the shaft, and at least IT6 for the body.

Table 8.1

Recommended accuracies of the shape of bearing surfaces for bearings			
Accuracy level of bearing	Location place	Admissible deviation of cylindricity	Admissible frontal runout of support surfaces towards the axis
P0, P6	shaft	IT5/2	IT3
	body	IT6/2	IT4
P5, P4	shaft	IT3/2	IT2
	body	IT4/2	IT3

Table 8.2

Basic tolerances IT2 to IT6						
Nominal diameter		Tolerance level				
over	to	IT2	IT3	IT4	IT5	IT6
mm		μm				
6	10	1,5	2,5	4	6	9
10	18	2	3	5	8	11
18	30	2,5	4	6	9	13
30	50	2,5	4	7	11	16
50	80	3	5	8	13	19
80	120	4	6	10	15	22
120	180	5	8	12	18	25
180	250	7	10	14	20	29
250	315	8	12	16	23	32
315	400	9	13	18	25	36
400	500	10	15	20	27	40

Allowed deviation of roundness and cylindricity and allowed frontal runout of bearing and support surfaces for bearings must be smaller against the axis than the scope of tolerance of the diameters of the journal and the bore. With increasing accuracy of the bearings used, also the requirements for the accuracy of bearing surfaces grow. The recommended accuracy values of the bearing surfaces shape for bearings are stated in chart 8.1, and general tolerances IT2 to IT6 in chart 8.2

Assembly and disassembly of bearing

If any of the rings is located with clearance (mobile), the assembly is easy. If the service conditions require that both rings are located with overlap, a suitable type of bearing has to be chosen, e.g. separable bearing (tapered, cylindrical, needle), or a bearing with tapered bore. Shaft journals for location of sleeves for bearing with tapered bore can be within the h9 or h10 tolerance, geometrical shape must be within the accuracy IT5 or IT7, depending on the complexity of location.

Axial displacement of free bearing races

At any service conditions the axial displacement of free bearing has to be ensured. If non-separable bearings are used, displacement of spot-loaded ring will be reached by locating with clearance (mobile location). In bodies made of light metal alloys the bore has to be sleeved with a steel sleeve, if outer ring is to be located with clearance. Reliable sliding ability in axial direction will be achieved if cylindrical roller bearings of N and NU designs or radial needle roller bearings are used in the location.

The recommended tolerances of journal and hole diameters of connecting pieces are for radial and axial bearings stated in charts 8.3 to 8.10.

Table 8.3

Tolerances of journal diameters for radial bearings (applies for full steel shafts)					
Service conditions	Examples of location	Journal diameter [mm]			Tolerance
		Ball bearings	Cylindrical roller, needle roller ¹⁾ , tapered roller bearings	Spherical roller bearings	
Inner ring spot load					
Small and normal load Pr ≤ 0.15 Cr	Free wheel, pulleys, belt pulleys	All diameters			g6 ²⁾
Big impact load Pr > 0.15 Cr	Wheels of conveyance trolleys, tension pulleys				h6
Circumferential load of inner ring or uncertain way of loading					
Small and variable load Pr ≤ 0.07 Cr	Conveyers, fans	(18) to 100 (100) to 200	≤ 40 (40) to 140	-	j6 k6
Normal and big load Pr > 0.07 Cr	General engineering, pumps, combustion engines, transmissions, woodworking machines	≤ 18 (18) to 100 (100) to 140 (140) to 200	- ≤ 40 (40) to 100 (100) to 140 (140) to 200 > 200	- ≤ 40 (40) to 65 (65) to 100 (100) to 140 > 140	j5 k5 (k6) ³⁾ m5 (m6) ³⁾ m6 n6 p6
Extremely big load, shocks heavy service conditions Pr > 0.15 Cr	Axle bearings of rail vehicles, traction motors, rolling mills	- -	(50) to 140 (140) to 500 > 500	(50) to 100 (100) to 500 > 500	n6 ⁴⁾ p6 ⁴⁾ r6 (p6) ⁴⁾
High location accuracy at small load Pr ≤ 0.07 Cr	Machine tools	≤ 18 (18) to 100 (100) to 200	- ≤ 40 (40) to 140 (140) to 200	- - - -	h5 ⁵⁾ j5 ⁵⁾ k5 ⁵⁾ m5 ⁵⁾
Axial load exclusively			all diameters		j6
Bearings with tapered bore and with adapter or withdrawal sleeve or dismantling sleeve					
All ways of loading	General locations, axle bearings of rail vehicles, Unexacting locations		all diameters		h9/IT5 h10/IT7

¹⁾ Does not apply to needle bearings without rings
²⁾ For bearings tolerance f6 can be selected to ensure axial shift
³⁾ Tolerance in brackets is selected usually for single row tapered roller bearings or at low frequency revolutions where clearance diffusion does not have major significance.
⁴⁾ Bearings with increased radial clearance have to be used
⁵⁾ Tolerances for single row ball bearings of accuracy P5 and P4 are stated in chapter 12.2

Table 8.4

Tolerance of diameters of radial bearing body bores (applies to bodies of steel, alloy and cast steel)				
Service conditions	Sliding ability of outer raceway	Body	Examples of location	Tolerance
Circumferential load of outer ring				
Big shock load $Pr > 0.15 Cr$ Thin-walled elements	Does not slide	Single piece	Hubs with roller bearings, crank pin bearings	P7
Normal and big load $Pr > 0.07 Cr$	Does not slide		Hubs with roller bearings travelling wheels of cranes, crank shaft bearings	N7
Small and variable load $Pr \leq 0.07 Cr$	Does not slide		Conveyer rollers, tension pulleys	M7
Uncertain way of loading				
Big shock load $Pr > 0.15 Cr$	Does not slide		Traction motors	M7
Big and normal load $Pr > 0,07 Cr$	Usually does not slide	Single piece	Electromotors, pumps, fans, crank shafts	K7
Small and variable load $Pr \leq 0.07 Cr$	Usually sliding		Electromotors, pumps, fans, crank shafts	J7
Accurate locations				
Small load $Pr \leq 0.07 Cr$	Usually does not slide		Roller bearings for machine tools, ball bearings for machine tools, small electromotors	K6 ¹⁾
	Sliding	Single piece		J6 ²⁾
	Slightly pushing			H6
Spot load of outer ring				
Optional load	Slightly pushing	Single piece or two piece	General engineering axle bearings of rail vehicles	H7 ³⁾
Small and normal load $Pr \leq 0.15 Cr$	Slightly pushing	Single piece or two piece	General engineering less exacting mechanical engineering	H8
			Paper machine drying cylinders, big electromotors	G7 ⁴⁾

¹⁾ For big load, stronger M6 or N6 tolerances are selected. For cylindrical roller bearings with tapered bore, tolerances K5 or M5 are selected.

²⁾ Tolerances for single row ball bearings of accuracy P5 and P4 are stated in chapter 12.2

³⁾ For bearings with outer diameter $D < 250$ mm with thermal difference between outer ring and body above 10 °C, tolerance G7 is selected

⁴⁾ For bearings with outer diameter $D > 250$ mm with thermal difference between outer ring and body above 10 °C, tolerance F7 is selected.

Table 8.5

Tolerance of journal diameters for axial bearings					
Bearing type	Way of loading		Journal diameter	Tolerances	
			[mm]		
Axial ball	Axial load exclusively		All diameters	j6	
Axial spherical-roller				j6	
	Current axial and radial load	Spot load of shaft ring	All diameters	j6	
		Circumferential load of shaft ring or uncertain way of loading		≤ 200	k6
				(200) to 400	m6
		> 400		n6	

Table 8.6

Tolerance of diameters of axial bearing body bores				
Bearing type	Way of loading		Note	Tolerances
Axial ball	Axial load exclusively		In common locations, the casing ring may feature clearance Casing ring is mounted with radial clearance	H8
				-
Axial spherical-roller	Current axial and radial load	Spot load or uncertain way of loading of casing ring		H7
		Circumferential load		M7
		Circumferential load		

Table 8.7

Limit deviations of journal diameter tolerances																	
Nominal diameter of journal		f6		g5		g6		h5		h6		j5		j6(js6)		k5	
		upper	lower	upper	lower	upper	lower	upper	lower	upper	lower	upper	lower	upper	lower	upper	lower
mm		µm															
1	3	-6	-12	-2	-6	-2	-8	0	-4	0	-6	2	-2	4	-2	4	0
3	6	-10	-18	-4	-9	-4	-12	0	-5	0	-8	3	-2	6	-2	6	1
6	10	-13	-22	-5	-11	-5	-14	0	-6	0	-9	4	-2	7	-2	7	1
10	18	-16	-27	-6	-14	-6	-17	0	-8	0	-11	5	-3	8	-3	9	1
18	30	-20	-33	-7	-16	-7	-20	0	-9	0	-13	5	-4	9	-4	11	2
30	50	-25	-41	-9	-20	-9	-25	0	-11	0	-16	6	-5	11	-5	13	2
50	80	-30	-49	-10	-23	-10	-29	0	-13	0	-19	6	-7	12	-7	15	2
80	120	-36	-58	-12	-27	-12	-34	0	-15	0	-22	6	-9	13	-9	18	3
120	180	-43	-68	-14	-32	-14	-39	0	-18	0	-25	7	-11	14	-11	21	3
180	250	-50	-79	-15	-35	-15	-44	0	-20	0	-29	7	-13	16	-13	24	4
250	315	-56	-88	-17	-40	-17	-49	0	-23	0	-32	7	-16	16	-16	27	4
315	400	-62	-98	-18	-43	-18	-54	0	-25	0	-36	7	-18	18	-18	29	4
400	500	-68	-108	-20	-47	-20	-60	0	-27	0	-40	7	-20	20	-20	32	5
500	630	-76	-120	-	-	-22	-66	-	-	0	-44	-	-	22	-22	-	-
630	800	-80	-130	-	-	-24	-74	-	-	0	-50	-	-	25	-25	-	-
800	1000	-86	-142	-	-	-26	-82	-	-	0	-56	-	-	28	-28	-	-
1000	1250	-98	-164	-	-	-28	-94	-	-	0	-66	-	-	33	-33	-	-

Table 8.8

Limit deviations of journal diameter tolerances																			
Nominal diameter of journal		k6		m5		m6		n6		p6		h9 ¹⁾		IT5		h10 ¹⁾		IT7	
		upper	lower	upper	lower	upper	lower	upper	lower	upper	lower	upper	lower	upper	lower	upper	lower	upper	lower
mm		µm																	
1	3	6	0	6	2	8	2	10	4	12	6	0	-25	4	0	-40	10		
3	6	9	1	9	4	12	4	16	8	20	12	0	-30	5	0	-48	12		
6	10	10	1	12	6	15	6	19	10	24	15	0	-36	6	0	-58	15		
10	18	12	1	15	7	18	7	23	12	29	18	0	-43	8	0	-70	18		
18	30	15	2	17	8	21	8	28	15	35	22	0	-52	9	0	-84	21		
30	50	18	2	20	9	25	9	33	17	42	26	0	-62	11	0	-100	25		
50	80	21	2	24	11	30	11	39	20	51	32	0	-74	13	0	-120	30		
80	120	25	3	28	13	35	13	45	23	59	37	0	-87	15	0	-140	35		
120	180	28	3	33	15	40	15	52	27	68	43	0	-100	18	0	-160	40		
180	250	33	4	37	17	46	17	60	31	79	50	0	-115	20	0	-185	46		
250	315	36	4	43	20	52	20	66	34	88	56	0	-130	23	0	-210	52		
315	400	40	4	46	21	57	21	73	37	98	62	0	-140	25	0	-230	57		
400	500	45	5	50	23	63	23	80	40	108	68	0	-155	27	0	-250	63		
500	630	44	0	-	-	70	26	88	44	122	78	0	-175	30	0	-280	70		
630	800	50	0	-	-	80	30	100	50	138	88	0	-200	35	0	-320	80		
800	1000	56	0	-	-	90	34	112	56	156	100	0	-230	40	0	-360	90		
1000	1250	66	0	-	-	106	40	132	66	186	120	0	-260	46	0	-420	105		

¹⁾ In journals manufactured within tolerances h9 and h10 for bearings with adapter or withdrawal sleeve, the circularity and cylindricality deviations must not exceed the basic tolerance IT5 and IT7.

Table 8.9

Limit deviations of bore diameter tolerances																	
Nominal diameter of bore		F7		G6		G7		H6		H7		H8		J6(Js6)			
		upper	lower	upper	lower	upper	lower	upper	lower	upper	lower	upper	lower	upper	lower	upper	lower
mm		µm															
6	10	28	13	14	5	20	5	9	0	15	0	22	0	5	-4		
10	18	34	16	17	6	24	6	11	0	18	0	27	0	6	-5		
18	30	41	20	20	7	28	7	13	0	21	0	33	0	8	-5		
30	50	50	25	25	9	34	9	16	0	25	0	39	0	10	-6		
50	80	60	30	29	10	40	10	19	0	30	0	46	0	13	-6		
80	120	71	36	34	12	47	12	22	0	35	0	54	0	16	-6		
120	180	83	43	39	14	54	14	25	0	40	0	63	0	18	-7		
180	250	96	50	44	15	61	15	29	0	46	0	72	0	22	-7		
250	315	108	56	49	17	69	17	32	0	52	0	81	0	25	-7		
315	400	119	62	54	18	75	18	36	0	57	0	89	0	29	-7		
400	500	131	68	60	20	83	20	40	0	63	0	97	0	33	-7		
500	630	146	76	66	22	92	22	44	0	70	0	110	0	22	-22		
630	800	160	80	74	24	104	24	50	0	80	0	125	0	25	-25		
800	1000	176	86	82	26	116	26	56	0	90	0	140	0	28	-28		
1000	1250	203	98	94	28	133	28	66	0	105	0	165	0	33	-33		
1250	1600	235	110	108	30	155	30	78	0	125	0	195	0	39	-39		

Table 8.10

Limit deviations of bore diameter tolerances															
Nominal diameter of bore		J7(Js7)		K6		K7		M6		M7		N7		P7	
		upper	lower	upper	lower	upper	lower	upper	lower	upper	lower	upper	lower	upper	lower
over	to	μm													
mm	mm	μm													
6	10	8	-7	2	-7	5	-10	-3	-12	0	-15	-4	-19	-9	-24
10	18	10	-8	2	-9	6	-12	-4	-15	0	-18	-5	-23	-11	-29
18	30	12	-9	2	-11	6	-15	-4	-17	0	-21	-7	-28	-14	-35
30	50	14	-11	3	-13	7	-18	-4	-20	0	-25	-8	-33	-17	-42
50	80	18	-12	4	-15	9	-21	-5	-24	0	-30	-9	-39	-21	-51
80	120	22	-13	4	-18	10	-25	-6	-28	0	-35	-10	-45	-24	-59
120	180	25	-14	4	-21	12	-28	-8	-33	0	-40	-12	-52	-28	-68
180	250	30	-16	5	-24	13	-33	-8	-37	0	-46	-14	-60	-33	-79
250	315	36	-16	5	-27	16	-36	-9	-41	0	-52	-14	-66	-36	-88
315	400	39	-18	7	-29	17	-40	-10	-46	0	-57	-16	-73	-41	-98
400	500	43	-20	8	-32	18	-45	-10	-50	0	-63	-17	-80	-45	-108
500	630	35	-35	0	-44	0	-70	-26	-70	-26	-96	-44	-114	-78	-148
630	800	40	-40	0	-50	0	-80	-30	-80	-30	-110	-50	-130	-88	-168
800	1000	45	-45	0	-56	0	-90	-34	-90	-34	-124	-56	-146	-100	-190
1000	1250	52	-52	0	-66	0	-105	-40	-106	-40	-145	-66	-171	-120	-225
1250	1600	62	-62	0	-78	0	-125	-48	-126	-48	-173	-78	-203	-140	-265

8.2.3 Axial security of bearings

Inner bearing ring with cylindrical bore seated on journal with overlap (fixed location) is usually locked in axial direction using a adapter nut, terminal plate or snap ring whilst the other face is usually leaned by the shaft fitting. Adjacent components are used as support faces for inner rings and, if needed, spacer rings are inserted between this component and the inner ring of the bearing. Examples of axial fixation of bearing are shown in figure 8.5.

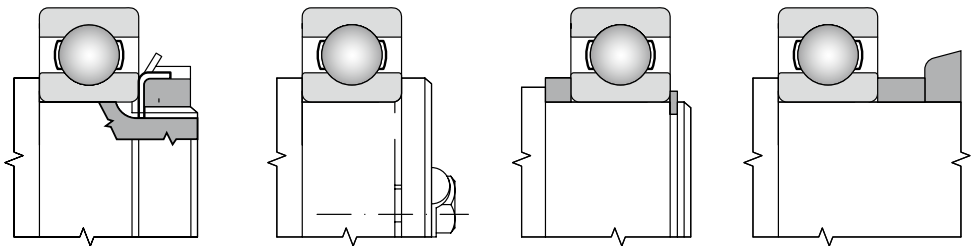

Fig. 8.5

Bearings with tapered bore mounted directly on tapered journal are usually secured with a safety nut screwed onto the thread on the shaft. If bearings are mounted on withdrawal sleeve, the inner ring must be supported, e.g. by a spacer ring. The spacer ring can form a part of labyrinth. The withdrawal sleeve is axially fixed with terminal plate or safety nut.

Examples of axial fixation of bearing with tapered bore directly on tapered journal or by means of adapter or withdrawal sleeve are shown in Fig. 8.6.

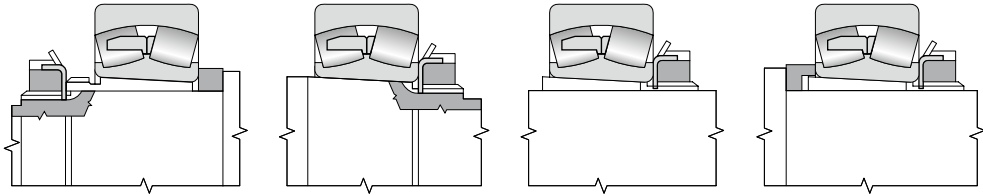

Fig. 8.6

Admissible axial load of bearings fixed by means of adapter sleeve on smooth shafts without the bearing leaning on shaft fitting is calculated by the below equation:

$$F_a = 3B \cdot d \quad [N]$$

F_a admissible axial load of bearing [N]

B bearing width [mm]

d bearing hole diameter [mm]

If axial displacement of outer ring in body is not desirable, we can use a solution utilising the front support surface or seating surface of the bearing lid, nut or snap ring. Bearings with a groove for snap ring (NR) are less demanding in space, and their locking is simple.

Examples of solution are shown in Fig. 8.7.

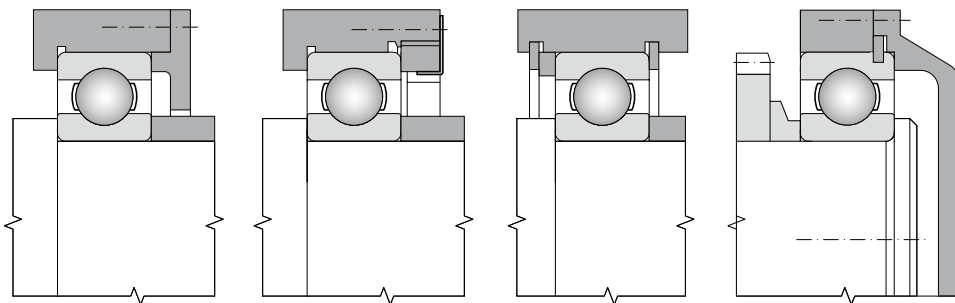

Fig. 8.7

Connecting dimensions for individual bearing types are stated in this publication in the chart section (chapter 12).

8.3 Seal

Sealing the bearing space is very important since harmful substances present in the proximity of the bearing affect it and often even put it out of service. Seal has also an opposite function – it prevents the grease from leaking out of the bearing and from the stowage compartment. For that reason, the seal has always to be designed considering the service conditions of the machine or equipment, lubrication method, maintenance options and economic aspects of production and use.

8.3.1 Contact-free sealing

This type of seal features only a tight gap between the non-rotary and rotary component which is sometimes filled with grease. In this design no wear due to friction occurs, and therefore this seal suits to use for highest circumferential speeds and high service temperatures. Examples of slotted seals are shown in fig. 8.8

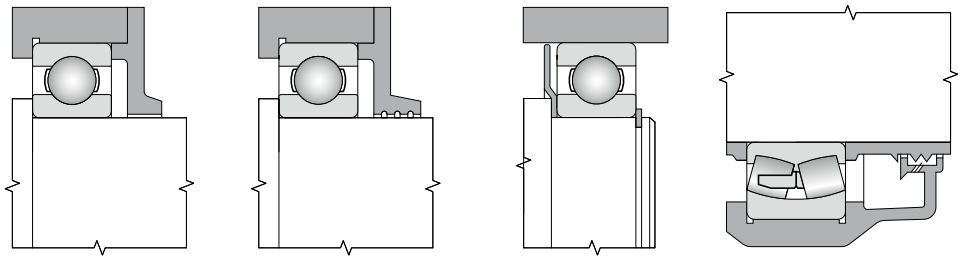

Fig. 8.8

Another very efficient seal is a labyrinth seal which can be used to enhance the packing effect by higher number of labyrinths or extension of sealing slots. See fig. 8.9. for examples of this seal.

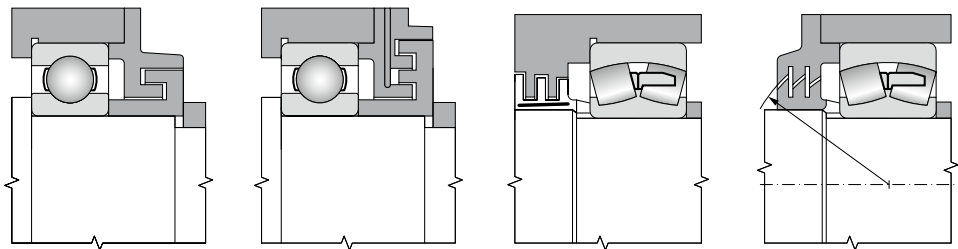

Fig. 8.9

8.3.2 Friction sealing

Friction sealing is made of elastic or soft but sufficiently solid and impermeable material that is inserted between the rotary and fixed component. Such seal is usually cheap and suits to various constructions. Disadvantage is sliding friction touching the surfaces which limits the use of it for high circumferential speeds.

The simplest is seal with a felt ring (fig. 8.10). It suits to service temperatures within $-40\text{ }^{\circ}\text{C}$ and $+80\text{ }^{\circ}\text{C}$ and to circumferential even to $7\text{ m}\cdot\text{s}^{-1}$, whilst the maximum required surface roughness of the sliding surface is $R_a = 0.16$, and minimum hardness 45 HRC or treatment by hard chromium plating. Dimensions of felt rings and grooves are solved by relevant national standards.

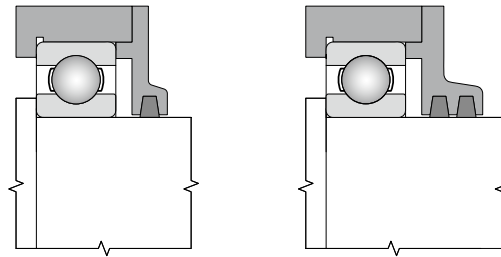

Fig. 8.10

A very frequent sealing method is sealing with shaft rings (fig. 8.11). Shaft rings are made of rubber or other suitable plastics, stiffened by metal stiffener. According by the material used they suit to service temperatures from $-30\text{ }^{\circ}\text{C}$ to $+160\text{ }^{\circ}\text{C}$. Admissible circumferential speed depends on the roughness of the sliding surface roughness.

- to $2\text{ m}\cdot\text{s}^{-1}$ the roughness is $\max R_a = 0.8$,
- to $4\text{ m}\cdot\text{s}^{-1}$ the roughness is $\max R_a = 0.4$,
- to $12\text{ m}\cdot\text{s}^{-1}$ the roughness is $\max R_a = 0.2$.

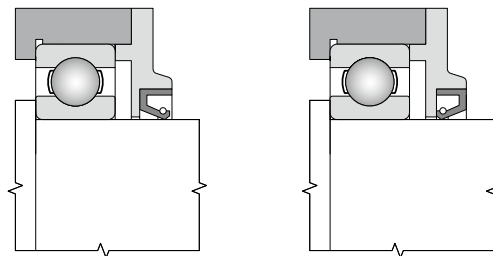

Fig. 8.11

Besides the stated most common sealing rings there are other friction seal designs that utilise specifically shaped sealing rings made of rubber, plastic, etc., or special elastic metal rings. This seal is either selected for locations with high demands on sealing the bearing space (bog contamination of ambient area, high temperature, effect of chemicals), or due to economic reasons in bulk and large lot production. Examples are shown in fig. 8.12.

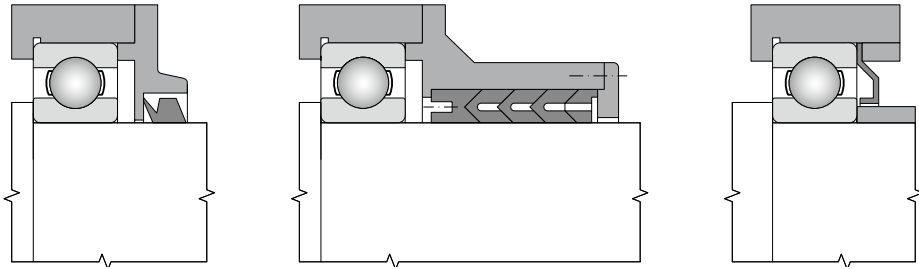

Fig. 8.12

8.3.3 Combined seals

Enhanced sealing effect is achieved by combination of contact-free and friction sealing. Such seals are recommended for humid and contaminated environment. Example is shown in fig. 8.13.

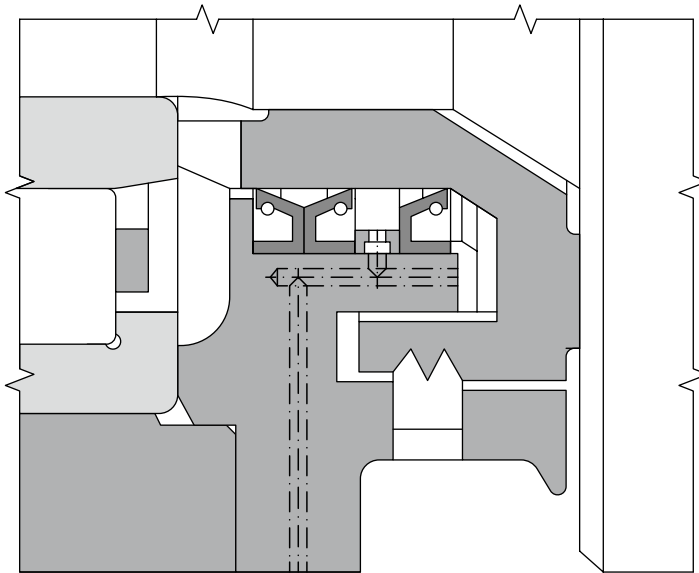

Fig. 8.13

9. BEARING LUBRICATION

The main purpose of lubrication is to reduce friction and wear inside the bearing. Slippage and rolling occur in the contact area between rings and rolling elements. The size of slippage depends on the type of bearing used, the load, and mode of lubrication. Elastohydrodynamic lubrication occurs in roller bearings under operating conditions and is characterized by a significant rise in pressure within the lubricating film inside of the contact area.

Main roles of lubricants:

- Decrease friction and wear – direct metal-to-metal contact between bearing rings, rolling elements, and cages is prevented by the use of lubricating film that decreases friction and wear in the contact areas.
- Extend fatigue life – bearing fatigue life depends, in particular, on the viscosity and film thickness of the lubricant between contact surfaces.
- Heat dissipation – oil circulation can dissipate excess frictional heat or heat from the external environment from the bearing, thereby protecting the bearing against overheating and the oil against degradation.
- Protection of bearing surface against corrosion
- Preventing entry of foreign particles (contaminants) into the bearing, removal of foreign particles from the bearing oil circulation.

9.1 Types of lubrication

Oil or grease are used under normal conditions for bearing lubrication, or in special cases solid lubricant is used, e.g. for extreme temperatures or operation in a vacuum. When deciding on the type and method of lubrication, one must consider the operating conditions, the characteristic properties of applied lubricant, the design of the equipment, and its operating efficiency. Oil lubrication provides better lubrication characteristics, but grease lubricants make for easier use in bearings.

A comparison between oil and grease lubrication is provided in table 9.1.

Table 9.1

grease lubrication	oil lubrication
low temperatures	high and extremely low temperatures
low speeds (65 % to 85 % of revolutions, which can be achieved during oil lubrication)	high rotational speed
protection against entry of contaminants (glands, covers)	oil seals to prevent leakage
long-term maintenance-free operation	bearings are lubricated from a central source, which also serves to lubricate other machine components
weak cooling	heat dissipation via oil circulation
removal of contaminants from grease not possible	easy removal of particles from lubricant using oil filter

9.2 Grease lubrication

Under normal conditions, most of the loadings use grease lubrication. An advantage of grease is that it holds better in the loading, it seals the housing against entry of contaminants, moisture, and water and, in particular, affords easier bearing maintenance.



Fig. 9.1

Bearing grease is most often produced from high-quality mineral or synthetic oils that are thickened using fatty acid metal detergents. Greases need to have good lubricating ability and high chemical, thermal, and mechanical stability. Greases can be enriched with additives that increase the service life of the grease and bearing. When selecting grease, the most important characteristics to consider are the viscosity of the base oil, its consistency, load-bearing ability, and anti-corrosion properties.

9.2.1 Composition of grease lubricants

- Base oil – most frequently a mineral-based or synthetic oil. Lubrication properties of the grease are usually given by the properties of the base oil. Base oil viscosity is the decisive factor when selecting grease. Greases produced from low-viscosity base oil are suitable for high speed and low temperature applications, and lubricants with high-viscosity base oil are preferred for high temperature and heavy load applications.
- Thickening agent – the type of thickening agent, in particular, affects the grease dropping point and determines the application for a particular operating temperature; the higher the dropping point, the higher the temperature resistance of the grease. The maximum operating temperature of grease however is affected by the thermal resistance of the base oil. The water resistance of grease depends solely on the type of thickening agent.

- Additives – greases often contain additives that enhance certain grease characteristics or extend its life. Among the most commonly used are antioxidants (extend life), corrosion inhibitors (improve corrosion resistance), and EP additives (extreme loads).

9.2.2 Basic grease characteristics

- Base oil viscosity – the grease viscosity is given by the base oil; it is the most important factor when selecting a grease and has the most significant effect on the thickness of the lubricating film in the contact area and hence the bearing life. The oil viscosity is defined as the measure of flow resistance during lubricant shear stress. The viscosity increases exponentially proportionally to the pressure and exponentially decreases proportionally to the temperature.
- Characteristics of captured oil – grease assumes all characteristics of the base oil, such as viscosity, freezing point, and flash point; such characteristics significantly influence the behaviour of grease.
- Consistency – greases are divided into several consistency classes according to the NLGI (National Lubricating Grease Institute) classification. The grease consistency should dramatically change within the temperature range and during mechanical loading. If an unsuitable grease consistency is selected for a given loading, then the grease may leak out of the bearing or may increase the rotation resistance and lead to insufficient oil release in the contact area.

9.2.3 Miscibility

Mixing of greases should generally be avoided. Mixing greases with different types of thickening agents can interfere with the composite and physical characteristics, which can lead to leakage of the lubricant from the bearing and potential bearing failure. Greases manufactured using the same thickener base and similar base oil can generally be mixed without any adverse effects.

An overview of roller bearing grease is provided in table 9.2.

9.2.4 Amount of lubricant

The amount of grease depends on the bearing loading design, the amount of free space, the characteristics of the grease applied, and the operating temperature. An abundant use of grease in the loading causes an increase in operating temperature. Generally, the bearing is filled with grease and the free space in the bearing loading is only partially filled. The amount of grease in the free space of the loading can be determined relative to the speed:

- 1/2 to 2/3 free space at speeds below 50% bearing limiting speeds.
- 1/3 up to 1/2 free space at speeds above 50% bearing limiting speeds.

The bearing with grease should be run in, so that the grease can be evenly distributed throughout the bearing and so the excess grease can leak out of the bearing; the bearing can then subsequently operate at maximum speeds. When the bearing is properly run in, the bearing temperature decreases and the operating temperature becomes stable.

Bearings operating at very low speeds, as well as the free loading space, should be fully packed with grease to protect the bearing against corrosion and entry of contaminants.

Table 9.2

Grease characteristics for roller bearings				
Grease type		Characteristics		
Thickening agent	Base oil	Heat range of use [°C]	Water resistance	Application
Lithium soap	mineral	-20 to 130	resistant	multi-purpose lubricant
calcium soap	mineral	-20 to 50	highly resistant	good sealing effect against water
sodium soap	mineral	-20 to 100	non-resistant	emulsifies with water
aluminium soap	mineral	-20 to 70	resistant	good sealing effect against water
lithium complex soap	mineral	-20 to 150	resistant	multi-purpose lubricant
calcium complex soap	mineral	-30 to 130	highly resistant	multi-purpose high temperature, high-load lubricant
sodium complex soap	mineral	-20 to 130	resistant	suitable for high temperatures, high loads
aluminium complex soap	mineral	-20 to 150	resistant	suitable for high temperatures, high loads
barium complex soap	mineral	-30 to 140	resistant	Suitable for high temperatures and loads
bentonite	mineral	-20 to 150	resistant	suitable for high temperatures and low speeds
polycarbamide	mineral	-20 to 160	resistant	suitable for high temperatures and medium speeds
lithium soap	silicone	-40 to 170	highly resistant	suitable for wide temperature ranges and medium rotational speeds
barium complex soap	ester	-60 to 140	resistant	suitable for high temperatures and high speeds

9.2.5 Re-lubrication

Bearings must be re-lubricated if the expected bearing life is longer than the uptime of the applied grease. The re-lubrication interval is significantly influenced by the type and size of the bearing, the operating speed and temperature, and by the type and quality of grease.

The re-lubrication interval is the period during which the grease possesses the required lubricating characteristics. After this period elapses, the bearing must be re-lubricated after thoroughly first removing the old grease from the bearing space. The recommended re-lubrication intervals for individual types of bearings under normal load ($P \leq 0.15 C$) and normal operating conditions is provided in the diagrams on figures 9.2 and 9.3. The diagrams apply for common greases for temperatures up to +70°C. At temperatures above +70°C, the re-lubrication intervals are reduced to one-half their original values for every increase of 15°C. At temperatures below 40°C, the re-lubrication intervals may be increased two-fold.

For small, in particular single-row ball bearings, the re-lubrication intervals are several-fold greater than the expected bearing life; consequently, such bearings are generally not re-lubricated. For the reason specified above, it is preferable to use such bearings designed with shields or with seals on both sides, which are filled with grease at the factory and which never require re-lubrication. After certain speeds, the re-lubrication period falls outside of the curve on the diagram; this means that the permissible grease lubrication threshold has been exceeded. In such cases, we recommend that the loading be designed for oil lubrication.

The grease should be re-filled whenever the re-lubrication interval is longer than 6 months. The re-lubrication intervals may be greater when using extreme performance grease. More information will be provided by the ZKL Technical and Consultation Services Department.

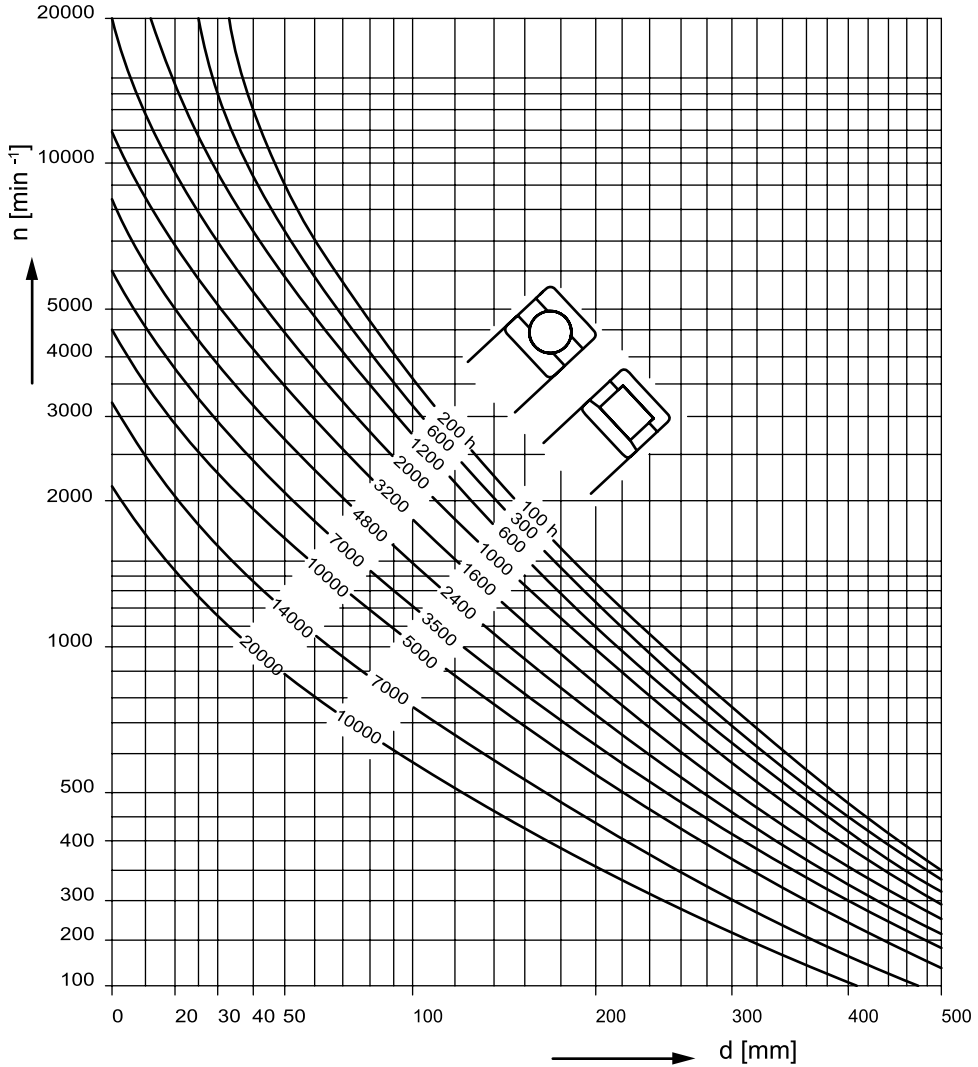

Fig. 9.2

The amount of grease required for re-lubrication can be calculated from the equation

$$Q = 0.005 \cdot D \cdot B \quad [g]$$

Q quantity of grease [g]

D outer bearing diameter [mm]

B bearing width [mm]

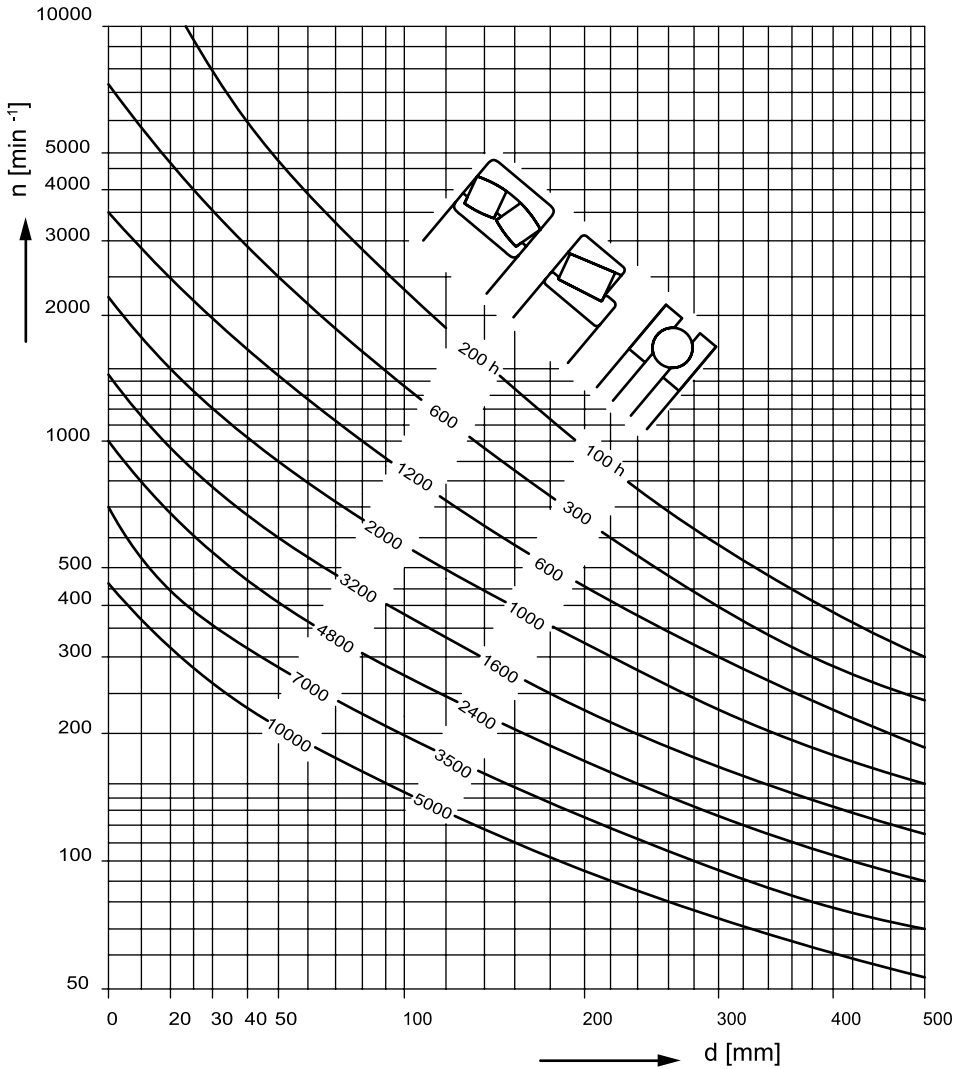

Fig. 9.3

Used grease should first be removed from the bearing space in high-speed bearings, requiring more frequent re-lubrication. This helps to prevent any undesired rise in operating temperatures. A grease slinger can be used to prevent bearing over-lubrication. It comprises a plate, which rotates on a shaft and the centrifugal force pushes out any excess and degraded grease through the slot in the housing out of the bearing (fig. 9.4).

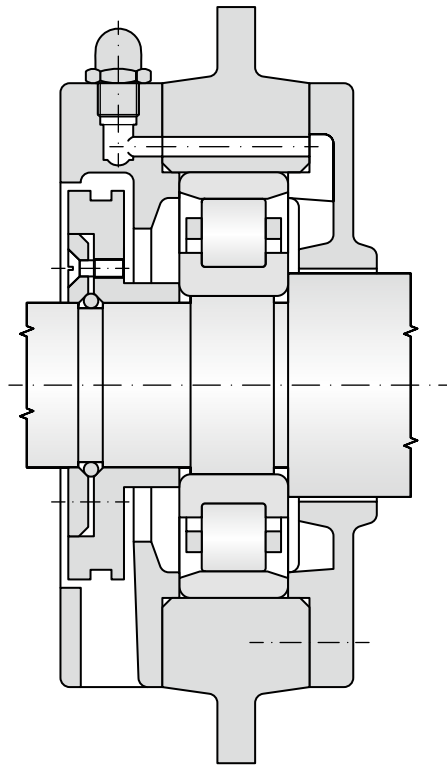

Fig. 9.4

Other factors affecting the re-lubrication interval:

- Vibrations – kneading of grease occurs during large vibrations and shocks, requiring more frequent re-lubrication. If grease becomes soft, grease with higher mechanical stability or stiffer grease must be used.
- Vertical shaft – the re-lubrication interval must be shortened by half and requires the use of glands and covers that prevent the leakage of grease from the loading.
- Contamination of grease – the re-lubrication intervals must be shortened, when the grease contains undesired particles, which can have a negative effect on the bearing life.

9.3 Oil lubrication

Oil lubrication is used when the rotation speeds are so high that the grease re-lubrication periods are too short. Another reason may be the need to dissipate heat from the bearing or when the temperature of the environment is high, which prevents the use of grease or if adjacent components already use an oil lubrication design (e.g. gearbox gears). With the exception of select spherical-roller bearings, such loadings are always lubricated with oil.

The use of oil lubrication necessitates that lubrication during running in and afterwards, during operation, be ensured. Excessive use of oil increases the oil temperature and thus the bearing temperature. The oil supply to the bearing is secured using various design methods:

- Oil bath lubrication – the most popular and simplest method of oil lubrication for low and medium rotational speeds. The oil level extends to the centre of the bottom rolling element and must be maintained at this level. The oil is carried by the rotating components of the bearing and dispersed in the bearing to return to the oil bath.
- Circulating oil lubrication – used most often in high speed applications, where the bearing needs to be cooled and for high temperature applications. Oiling is achieved by a pump. After the oil passes through the bearing, the oil is fed back into the sump, re-filtered, and cooled, as needed.
- Drop lubrication – is widely used for lubrication small ball bearings used in high speed applications.
- Oil splash lubrication – oil is splashed on the bearing by a rotating gear wheel or by a simple rotor adjacent to the bearing. The bearing does not need to be immersed in the oil bath; this method of lubrication is often used in automobile transmissions.
- Oil injection lubrication – generally used for high-speed bearings. Oil is injected under pressure directly into the bearing. The oil jet velocity must be sufficiently high to ensure that the oil penetrates through the swirling air created by the rotating parts of the bearing.
- Oil mist lubrication – injects an oil mist into the bearing. This method of lubrication is often used for lubricating spindle bearings of machining centres.
- Oil-air lubrication system – compressed air is used to supply a very small, precise amount of oil into each bearing to ensure sufficient lubrication and to better achieve lower operating temperatures and higher speeds. This lubrication method is used for lubrication most spindle bearings and for other high-speed applications.

9.3.1 Oil lubricants

Refined oils, with good chemical stability, are generally used for lubricating bearings. Stability can be improved by the use of antioxidant additives. Mineral oil without additives is generally preferred for lubricating roller bearing; additives are used only in special circumstances. Synthetic oils are intended solely for demanding applications at extreme temperatures (high or low).

Certain types of bearings, e.g. spherical-roller bearings, spherical-roller thrust bearings, or tapered roller bearings usually achieve higher operating temperatures than other types such as, e.g. ball bearings or roller bearings under identical operating conditions. This must also be considered when selecting the type of oil.

The decisive characteristic of oil is its kinematic viscosity, which decreases as the temperature increases. We can determine the appropriate oil viscosity from the diagram on fig. 5.4 in relation to the mean bearing diameter $d_s = (d+D)/2$ and the rotating speed.

If the operating temperature is known or can be identified, a suitable oil and viscosity on fig. 5.5 can be determined using the internationally standardized reference temperature of 40 °C, required for calculating the X ratio. Figures can be found in chapter 5 Determining the bearing size.

The use of oil with EP additives is recommended when the X ratio < 1, since they increase the oil film bearing capacity. Oil with EP additives must always be used, whenever the X value falls below 0.4. Improved reliability of the respective loading design is achieved if X > 1.

Example:

- bearing: $d = 180 \text{ mm}$, $D = 320 \text{ mm}$, $d_s = 250 \text{ mm}$
- rotation speed $n = 500 \text{ min}^{-1}$
- expected operating temperature 60 °C

According to the diagram on fig. 5.4, the minimum kinematic viscosity required to meet these conditions is

$$\nu_1 = 17 \text{ mm}^2\text{s}^{-1}$$

Adjusting for an operating temperature of 60 °C, the applied oil, selected according to the diagram on fig. 24 at a standardized temperature of 40 °C, must have a minimum kinematic viscosity of 35 mm²s⁻¹.

The kinematic viscosity of lubricating oil for spherical-roller thrust bearings is estimated according to table 9.3 relative to the product $n \cdot d$, where n is the bearing rotation speed in revolutions per minute and d is the bore diameter in mm. Lower viscosity values apply for low-load bearings, for which the relationship $P_a \leq 0.1 C_a$ applies. Higher values apply for $P_a > 0.1 C_a$.

Table 9.3

Oil viscosity for spherical-roller thrust bearings	
$d \cdot n$	kinematic viscosity of oil [mm ² s ⁻¹ at 40 °C]
1 000	250 to 550
10 000	100 to 250
100 000	45 to 100
200 000	30 to 80

9.3.2 Changing oil

The oil change interval depends on operating conditions and the oil quality used. If the operating temperature is less than 50 °C and the oil works in good operating conditions with and in a low dust environment, the oil is regularly changed once annually. If the oil temperature ranges near 100 °C, the oil must be changed approximately once every three months. The more demanding the operating conditions, the more frequent the oil changes to ensure lubricant purity and adequate state of oxidation. The use of specialized types of oils for specific operating conditions may significantly extend their uptime.

9.4 Lubrication using solid lubricants

Solid lubricants are used for lubricating bearings only in cases, when grease or oil are unable to meet the demands for reliable lubrication under limiting friction conditions or when required to provide adequate resistance against high operating temperatures, chemicals, and similar other effects.

Graphite, MoS_2 , and PTFE, in particular, are used for bearing lubrication. The lubricating mechanism is given by the lattice structure of compounds; the layers of particles easily slide along each other and adhere well to a metal surface, which prevents the displacement of lubricant particles during sliding or rolling motions.

Drawbacks of solid lubricants:

- High coefficient of friction
- Inability to act as a coolant
- Limited uptime
- Low dampening of vibrational instability of rolling elements and cage

10. ASSEMBLY AND DISASSEMBLY OF BEARINGS

10.1 General information

Roller bearings are strongly stressed machine components parts of which feature high accuracy. To be able to utilise fully functional properties of bearings and avoid damaging them before the end of their service life, assembly and potentially disassembly procedures have to be correctly specified. To do so, the structure of location has to be well known, suitable workplace and assembly tools made available to simplify the assembly and disassembly of bearings. It is very important that the assembly is performed by workers who are properly qualified and equipped with protective equipment.

10.2 Assembly worksite

Worksite must be equipped with suitable assembly tools and jigs to make the work comfortable and also safe. Equipment varies by the type and size of bearings to be assembled at the worksite. Very important is to make sure that these tools are clean and the work is performed in a clean working environment. In negative sense, impurities have decisive impact on the run of bearing when it is in service. Depending on the size and origin of impurities they may cause increased noise level of bearing and may also cause a bearing failure. The same conditions of cleanliness have to be applied in the preparation of all lubricating agents and components associated with location. Assembly worksite has to be therefore separated from normal production and only reserved for assembly of bearings. The worksite must be sufficiently spacious, dry and dust-free. No adjustments of components are supposed to be performed there, such as polishing, drilling or welding that could cause impurities to penetrate into the location area, or no air compressing devices shall be used in the proximity. The worksite shall not be exposed to weather effect since bearings are very sensitive to humidity, especially after being washed off preservative agents or old lubricant.

10.3 Work procedures

Prior to the commencement of every assembly the work procedure has to be specified based on drawing documentation to define individual work steps. In special cases that differ from common practice, detailed assembly instructions have to be provided, containing all assembly details, such as specification of needed work tools and equipment for assembly and disassembly, measuring instruments, special tooling, way of heating the bearings up, type and amount of lubrication, etc.

10.4 Preparation of bearings for assembly

Prior to the assembly, the fitter has to make sure whether the designation stated on the bearing corresponds with that on the bearing packaging stated on the drawing. The fitter should have basic knowledge of roller bearing identification system.

ZKL bearings are in original packaging protected with a preservative agent against corrosion for a period of 5 years on condition of proper storage. In order to maintain cleanliness, bearings are taken out of the packaging just before the assembly. Only in exceptional cases the bearing is cleared of preservative agent. Damaged packaging indicated potential contamination of bearings during the storage; so the bearings always have to be washed out prior to the assembly. Various cleaning agents can be used to wash out bearings – organic or inorganic. One can use e.g. benzine with 5 to 10 % addition of oil, petroleum, alcohol or dehydrating fluids. Majority of these agents are flammables – this have to be borne in mind. An alternative are alkaline cleaning agents but these are caustic substances.



Bearings are washed out in a clean suitable tank using a brush or a fibre-free cloth. During the washout one of the bearing rings have to be rotated with. If one bath is not sufficient to wash out the bearing, multiple baths are used depending on the level of contamination. After the washout, the bearing has to be provided with protective oil or grease layer depending on the type of lubrication to be used in run. During preservation, one ring of the bearing is slowly rotated with so that the raceways of both rings as well as the surface of rolling elements come to contact with the preservative agent.

After preservation, the bearing has to be protected from contamination and mounted to respective place as soon as possible. The anticorrosive agent that is used for preservation of ZKL bearings is compatible with majority of commonly used greases and need not be removed before the assembly. It is only recommended to wipe the surface and hole of the bearing to ensure proper location of the bearing.

No additional mechanical adjustment shall be done on roller bearings, such as making bores for supply of lubricant, slots, recesses, etc., since this might release tension in the rings that would cause early damage to the bearing. Besides that, there is a risk that the bearing can be contaminated with splinters or abrasion dust.

When handling bearings one needs to use gloves and lifting equipment to simplify the operation and enhance work safety. If you need to lift bearings in vertical position, we recommend to suspend them on a steel belt or strap on the outer ring circumference and not in one spot only. To lift bearings in horizontal position we recommend that big bearings are, upon a special request, provided with tapped bores for lifting lugs that will simplify subsequent handling. Suspension screws must however be loaded exclusively in the direction of the shank axis.

10.5 Preparation of location components for assembly

Prior to the assembly, all located parts must be thoroughly clean and cleared of burrs caused during their machining. Unmachined surfaces of the inside of rolling location bodies must be perfectly clean and cleared of the moulding sand residues, and provided with a protective coating. Also, all lubrication holes and threads have to be cleared thoroughly. All sharp edges need to be bevelled.

Prior to the assembly itself you need to check that the defined tolerances, geometrical accuracy and quality of bearing saddle surface and that in the body have been met. The accuracy of rolling bearings' dimensions need not checked prior to the assembly.

To ensure reliable operation of bearings, bearings must not be mounted on shafts which do not guarantee the accuracy of geometrical shape, on bended shafts or on shafts with mechanical damage. Therefore the shaft has to be checked carefully prior to the assembly. Depending on the size of the shaft, the accuracy of shape in tips can be checked on the lathe (fig. 10.1) or in supports by means of pointer indicator or micrometer.

Cylindrical journal can be checked using a snap gauge or micrometer in two planes perpendicular towards the journal axis. Two measurements are to be performed in each plane (fig. 10.2).

Additionally, the fitting and fillet of transit on the shaft have to be checked. It is very important that the perpendicularity of fitting the frontals towards to cylindrical seating surface axis for bearings was as accurate as possible. Bearing ring must seat with the entire surface on the front surfaces of the support. Major deviations of frontal surface perpendicularity cause additional tensions in bearings and ring deformation when the rings are pressed on and in axial load. At higher revolution frequencies these strains negatively affect the run of the bearing. The method of measuring the perpendicularity of the fitting forefront is indicated in fig. 10.3.

Tapered journals are checked by taper gauge (mostly taper 1:12) which has to be seated on the entire surface.

Bearing bodies are checked in the same way as journals [fig. 10.4] using an internal micrometer or a gauge. We also check the concentricity of seating surfaces in the body, especially if ball and roller bearings are mounted. Split cases have to be checked for not forming a bore on the body after tightening the connecting screws which would result in undesirable gripping and deformation of the outer ring of the bearing.

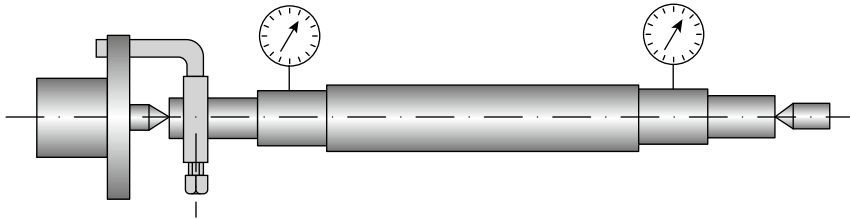

Fig. 10.1

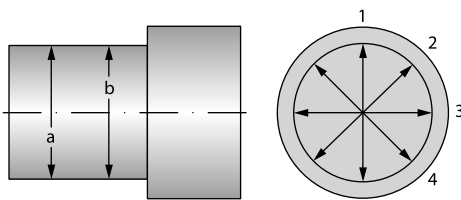

Fig. 10.2

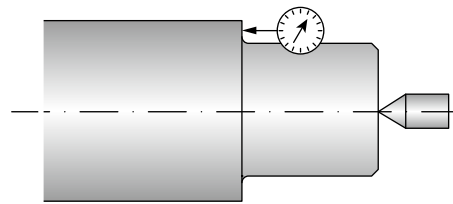

Fig. 10.3

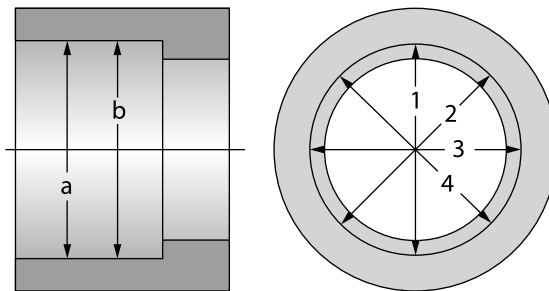

Fig. 10.4

It is recommended to record the results of measuring. During the measuring it has to be made sure that the measured parts and measuring instruments have approximately the same temperature. This is of special importance when big and heavy bearings and related parts are measured.

We also recommend that prior to the assembly the locations of bearings are provided with mounting lubricant. Mounting lubricant can be used for any fixed and sliding locations. It simplifies the assembly itself, prevents occurrence of joint corrosion and makes easier subsequent disassembly of the bearing from location.

10.6 Assembly of bearings with cylindrical bore

Different types and sizes of roller bearings require different assembly procedure. In principle, direct hammer strokes on the ring flanges, on cages or rolling elements have to be avoided during the assembly. When assembling non-separable bearings, the mounting force must act on the ring located with overlap that is mounted as first. In no case shall the mounting force be transferred via the rolling elements of the bearings. Thus the bearing is firstly mounted on journal by loading via the inner ring and then the entire bearing is pushed in the body where the location is usually sliding (fig. 10.5). If a non-separable bearing with overlap on shaft and in body is mounted, the mounting force must act on both rings equally (fig. 10.6). Rings of separable bearings can be assembled separately.

Bearings are mounted in location units either cold or heated.

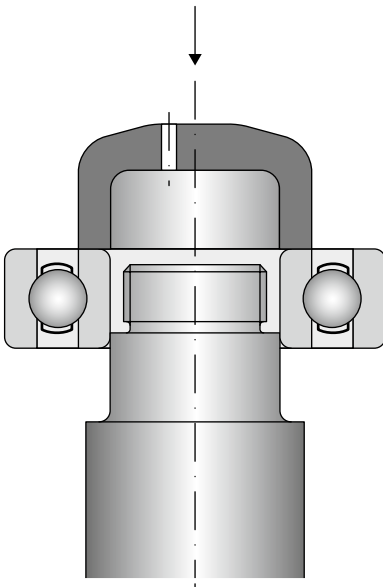

Fig. 10.5

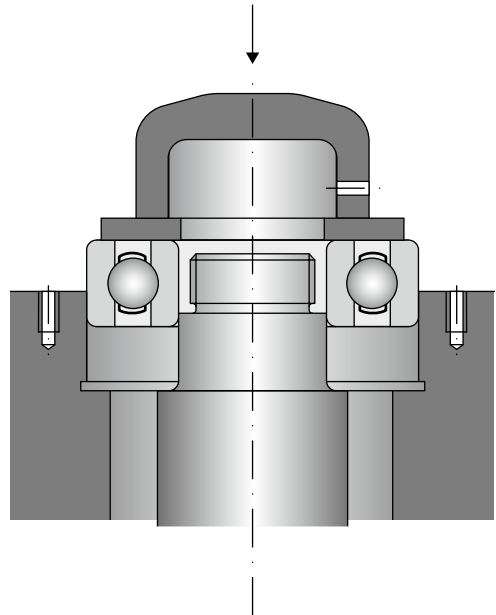

Fig. 10.6

10.6.1 Cold assembly

Bearings with smaller dimensions, up to bore diameter of 80mm can be cold mounted with common overlap. The force needed for assembly is achieved by means of press. Pressing is recommended to be performed using assembly jigs. If no press is available, smaller bearings can be mounted by means of light hammer strokes via the mounting sleeve leaned on the pressed ring. Hydraulic nuts can also be conveniently used in cold assembly.

10.6.2 Hot assembly

Hot assembly is used for bigger bearings rings of which are usually located with higher overlap. During the process, inner rings, alternatively entire bearings and bodies in which the bearings are mounted, are heated up prior to the assembly. We recommend that the assembly procedure with bearing temperature heat-up above 100 °C is discussed with the workers of the ZKL technical and consultancy services.

To ensure fast, safe and clean heat-up of bearings it is recommended to use induction heating equipment to ensure uniform heating of bearings without the risk of local overheating. Individual bearings of smaller dimensions can be heated on electrical hot plate with thermostatic control. Bearings have to be turned several times during the heating. Medium sized bearings can be heated by hot air reheat case with thermostatic control. The time of heating is however relatively long.

Roller bearings of all types and sizes can be heated in oil bath (fig. 10.7). This way of heating does not suit heating of sealed bearings, bearings with plastic lubricant filler and accurate bearings. Oil filler should be provided with thermostatic control (temperature between 80 and 100 °C) but usual heating is 50 to 60 °C above ambient temperature, i.e. oil is heated up to 70 to 80 °C. In the bath, bearings have to be placed on a grid or suspended in the bath to avoid their direct contact with the heated surface which might lead to overheating. Heating in oil bath however has a number of disadvantages, mostly the risk of injury, pollutant load with oil vapours, risk of hot oil inflammation and risk of bearing contamination.

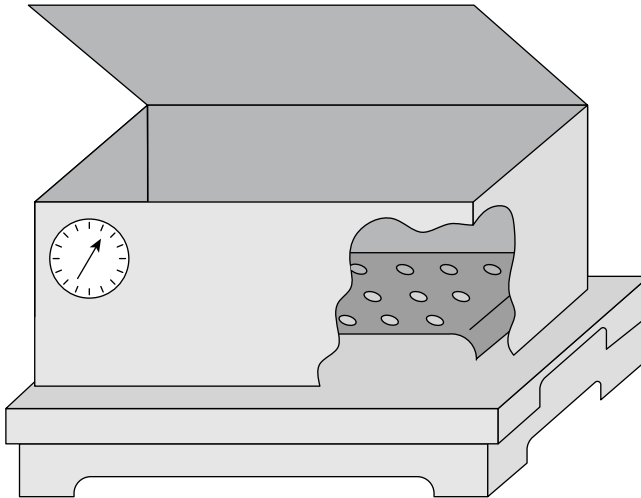

Fig. 10.7

10.7 Assembly of bearings with tapered bore

Bearings with tapered bore are mounted on shaft by means of adapter or withdrawal sleeves, or alternatively directly on tapered journal. Inner ring with tapered bore is always placed on the journal firmer than a ring with cylindrical bore. Fixed location is achieved either by pressing the inner ring on by means of a nut or a tapered sleeve. In both cases the inner ring will expand and cause reduction of radial clearance in the bearing. Therefore a method has to be determined that would correctly specify the overlap. This can be achieved by measuring the radial clearance reduction using a feeler gauge. The clearance before and after assembly must be measured between the inner ring and unloaded rolling element. This method suits to medium size and big spherical-roller bearings. Other methods are e.g. measuring of the lock nut torque angle or measuring of axial displacement of the inner ring on the tapered journal. In the assembly of double row self-aligning ball bearings, the adapter sleeve nut can be tightened to such extent that the inner ring can be smoothly turned and tilted. The assembly method should be consulted with the manufacturer.

Reliability of fixation of spherical-roller bearings can be checked by measuring of axial displacement of the inner ring on the journal or tapered sleeve. The initial position for measuring of this displacement will be achieved when the contact surfaces (of the ring, sleeve, shaft) abut against each other on the entire bearing surface. The values of axial displacement for the assembly of double row spherical-roller bearings with tapered bore are stated in chart 5, chapter Spherical-roller bearings.

Small bearings of bore diameter up to 80 mm can be pressed on a tapered journal, adapted sleeve (fig. 10.8) or the withdrawal sleeve (fig. 10.9) by means of terminal nut that is tightened by a mounting spanner. Prior to the assembly, the contact surfaces have to be coated by oil.

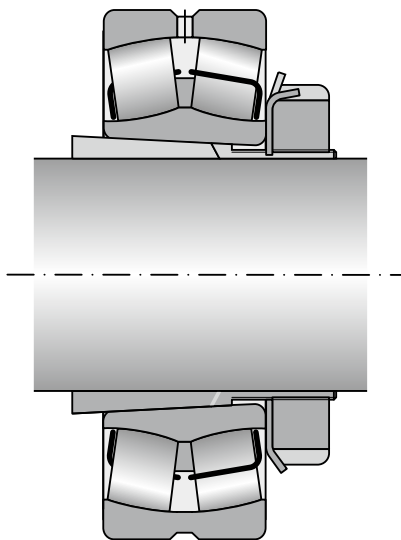

Fig. 10.8

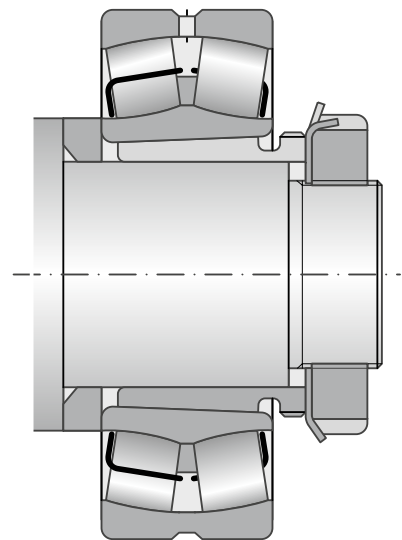

Fig. 10.9

Bigger bearings require much bigger mounting force, and that's why hydraulic nut or pressure oil method should be applied in their assembly, when oil is brought between the contact surfaces of the ring and journal under high pressure (fig. 10.10). This creates an oil film that reduces friction between the bearing surfaces. This method can be used also for the assembly onto adapter sleeves or withdrawal sleeves that are modified to suit this method. Use of oil of 75 mm²/s viscosity at 20 °C is recommended for the assembly (nominal viscosity at 40 °C is 32 mm²/s).

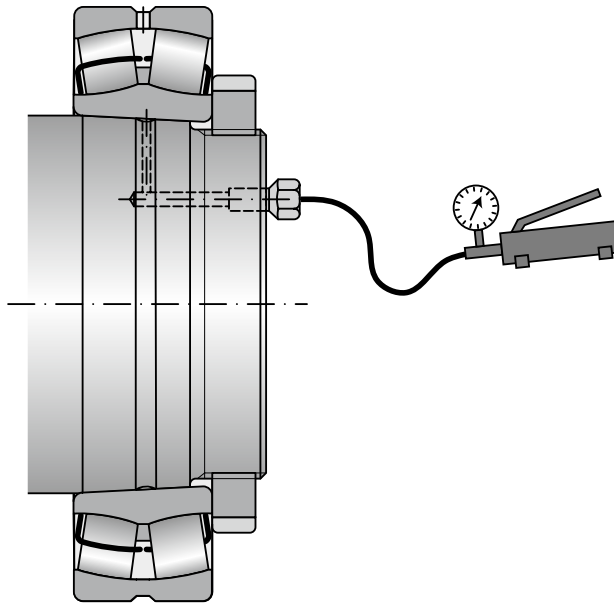

Fig. 10.10

10.8 Disassembly of bearings with cylindrical bore

If bearings and related parts are to be reused, the disassembly has to be paid particular attention. Non-separable bearing is always dismantled by force acting on the ring located with overlap. In separable bearings they are dismantled one by one, analogically with the assembly of these bearings.

For disassembly of smaller bearings mechanical pullers or hydraulic presses (fig. 10.1) should be used. The disassembly can be simplified by means of a groove on the shaft or in the body that will allow engagement of the puller on the ring mounted with overlap. To dismantle inner rings of heat mounted cylindrical roller bearings one should use induction tools.

To dismantle bearings with fixed location on cylindrical journal also the procedure using pressure oil can be applied (fig. 10.12). This method significantly simplifies the disassembly in cases when big pulling force would have to be applied. The use of this method requires provision of a location with canals and distribution grooves for supply of pressure oil in the bearing inner ring location. The supplied oil significantly reduced the force necessary for bearing disassembly that has to be performed with the help of suitable dismantling equipment, even if this method is applied. Once the oil separates the surfaces of the bearing location which becomes obvious when the oil starts infiltrating, we will pull the bearing down rapidly, without an interruption. If the bearing blocks once the oil canal on the shaft gets partially uncovered, we either have to heat it, or pull down applying considerable force by means of hydraulic tooling.

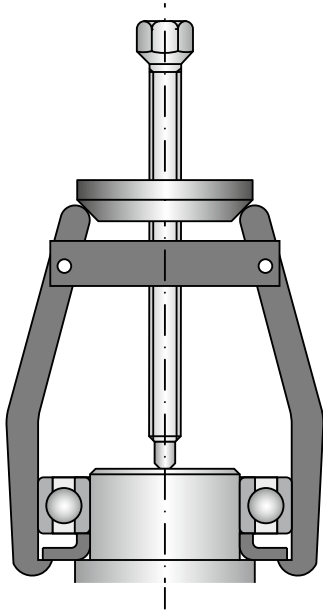

Fig. 10.11

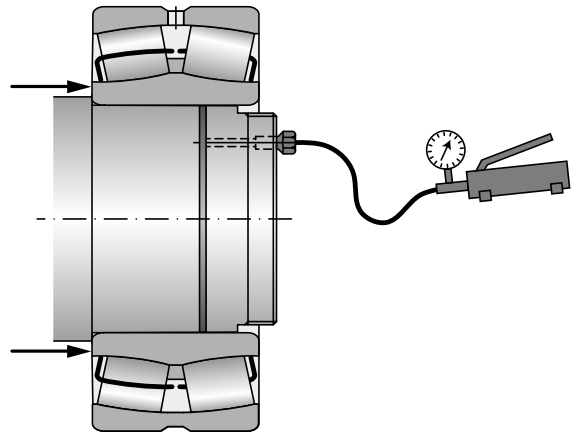

Fig. 10.12

To disassembly inner rings of cylindrical roller bearings without guide flanges or with one guide flange also heating rings can be used (the so-called thermo rings). These are tools made of light alloy, provided with radial grooves (fig. 10.13). This alternative is a cheaper option to induction equipment, mainly for dismantling of bearings with bore diameter exceeding 400 mm, or bearings that are dismantled only sometimes. A thermo ring is heated on an electrical hot place to the temperature of 280 °C approximately, slipped over a dismantled bearing ring and clamped in grips. After pulling the cylindrical roller bearing inner ring off the journal, the ring has to be taken off the thermo ring immediately to prevent it from overheating.

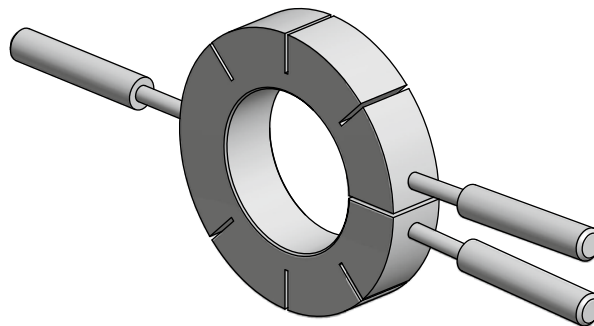

Fig. 10.13

10.9 Disassembly of bearings with tapered bore

If a bearing is mounted on a tapered journal or on an adapter sleeve, first the lock of the terminal nut or the adapter nut has to be removed. The nut is loosened by the distance necessary to release the bearing. Alternatively, another holdback can be used. After pulled down from the tapered journal the bearing will release at a swoop, and without this holdback there is a risk that the bearing will fall down of the shaft.

Disassembly of small and medium size bearings off tapered journal proceeds often by means of pullers that are fastened by the inner ring of the bearing or a support part, such as labyrinth ring. Already when designing the location the layout of suitable bores or grooves for puller arms should be considered. Inner rings of small bearings can be pulled down by means of press or hammer and spine. If press is used, the adapter sleeve has to be leaned and force applied on the inner bearing ring (fig. 10.14).

Bearings that are fastened by means of an adapter sleeve are dismantled by means of terminal nut (fig. 10.15). When big bearings are dismantled and therefore bigger force has to be applied, trust screws guided by nut can be used (fig. 10.16). A washer has to be put between the inner bearing ring and the screws in order to prevent damage of the bearing. Very fast, simple and economic is disassembly of a withdrawal sleeve by means of hydraulic nut. If the bearing is on the edge of the journal, it is recommended that the hydraulic nut is before the disassembly locked with a jig fastened e.g. to the front of the shaft (fig. 10.17).

Big withdrawal sleeves usually have canals and grooves for pressure oil. Oil is thus supplied directly by the pulling nut between the shaft and the sleeve, and between the sleeve and the bearing (fig. 10.18). After pressurised, contact surfaces can be shifted against each other without a risk of damage. Needed pressure is achieved by oil injectors. For the disassembly oil with low viscosity is used, approx. 150 mm²/s at 20 °C is required (nominal viscosity at 40 °C is 46 mm²/s).

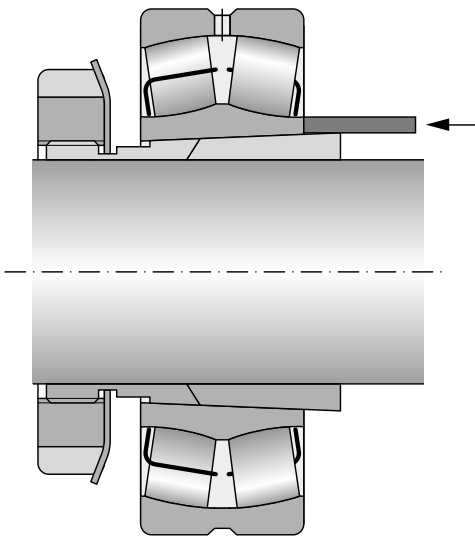

Fig. 10.14

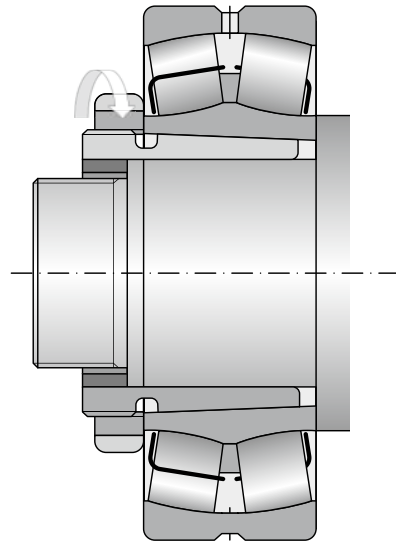

Fig. 10.15

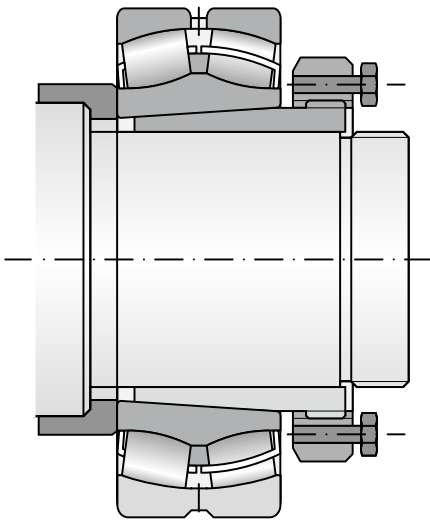

Fig. 10.16

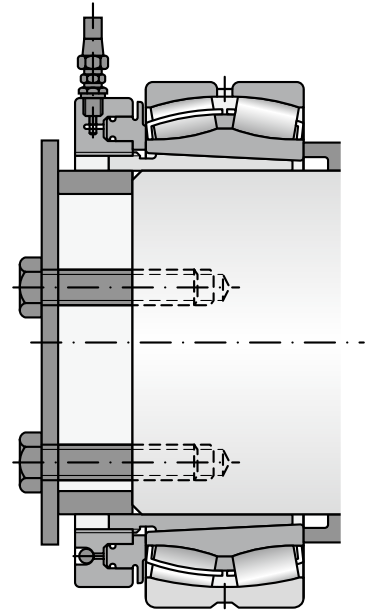

Fig. 10.17

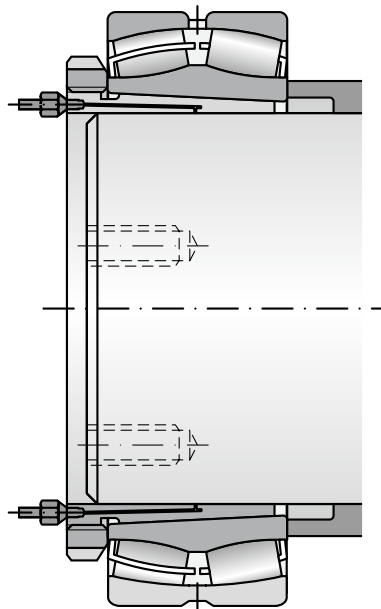

Fig. 10.18

10.10 Storage of bearings

ZKL bearings are stored and packed in a way that maintains the properties of the bearings as long as possible. The prerequisite for achieving these goals is achieving the conditions for storage of bearings and handling them.

Relative air humidity in the storage should not exceed 60%, and there should be no major temperature oscillations. Most convenient temperature range for storage of bearing is between 15 and 25 °C.

Bearings should not be exposed to vibrations and shocks. When stored, bearings must not be exposed to aggressive media, such as gases, fog or aerosols of acids, lyes and salts. Also the effect of direct sunlight has to be prevented since it may cause major temperature oscillations in the container. Big bearings, especially those of light series, must not be stored as standing. They should be placed horizontally to avoid deformation of rings. Bearings must not be stored in racks made of fresh timber or on a stone floor. Bearings must not be placed in the proximity of heating or water piping.

10.10.1 Storage period

If preserved in usual manner, bearings can be stored up to five years as long as the above specified conditions are met. Otherwise shorter storage term has to be counted with.

If the admissible storage terms are exceeded we recommended that bearings are checked in terms of preservation and corrosion.

If possible, both-side shielded (ZZ) or sealed (2RS) bearings should not be stored until the end of the storage term. During the storage, grease filler may get old due to chemical and physical processes. Bearings can be functional but the lubricant may be useless. The recommended time of storage of bearings with grease is two years.



11. BEARING DEFECTS AND DAMAGE

Just as other mechanical components, roller bearings can also undergo premature failure or housing defects for various reasons. One must differentiate bearing durability determined by load fatigue during operating speeds and bearing service life, which determines the bearing uptime, before a bearing is for various reasons decommissioned.

Durability and the systemic approach to calculating fatigue damage is described in chapter 5. Determining bearing size. Bearing durability is affected, e.g. by improper installation, poor selection of bearings, production errors when manufacturing connecting parts, handling of bearings by unqualified personnel, the entry of contaminants into bearings, or improper lubrication. If bearings show signs of damage or other deficiencies, the cause of such damage must be determined to enable the adoption of measures that would prevent their recurrence.

This often involves more than a simple analysis, especially if there are several concomitant factors or if the damage is so extensive that the initial site of damage cannot be ascertained. Incipient damage is usually demonstrated during operation by increased vibration, temperature, or noise. Sophisticated housing designs should thus be monitored during operation with diagnostic systems and the equipment should be shut down in the initial stages of damage.

11.1 Main types of damage

Examples of main types of roller bearing damage are illustrated in the following figures.

Flaking of the surface

Unacceptable tearing off of material due to thermal overloading of the bearing is shown in fig. 11.1 and 11.2.

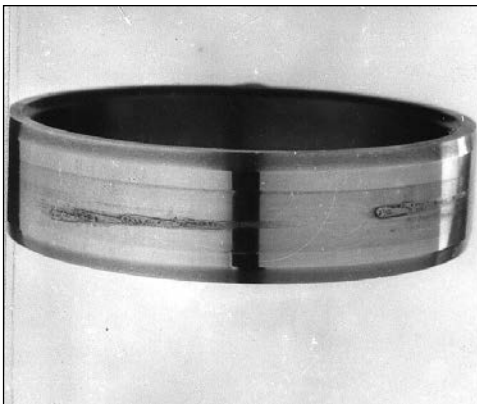

Fig. 11.1

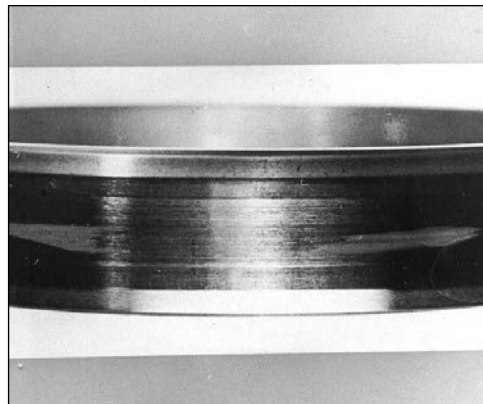

Fig. 11.2

Typical fatigue effect – pitting, which forms on the bearing rings, is shown on fig. 11.3 and 11.4. This damage is the result of cyclical loading of bearing components and is caused by normal fatigue of the material. The first cracks emanate from miniature non-homogeneities in the material at a particular depth below the surface. They are often, however, caused by overloading, insufficient lubrication, or other operating influences. Their timely identification can better help analyse and eliminate the cause. The figures illustrate unacceptable wear.

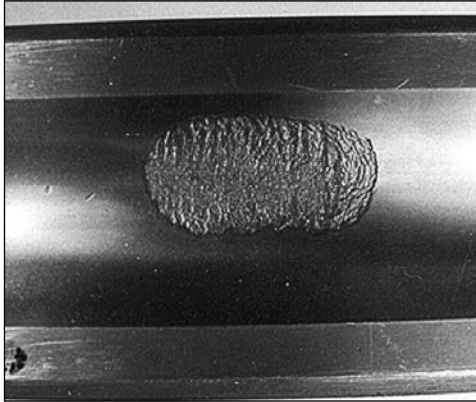

Fig. 11.3



Fig. 11.4

Depressions and pressure damage

Damage to bearing rings caused by indelicate installation (fig. 11.5) and shallow depressions in the raceway caused by beading of solid impurities during bearing operation (fig. 11.6). The extent of damage in both illustrated cases is unacceptable and may form the initial site of progressive fatigue damage – pitting. Damage to raceway caused by improper installation are usually easily discernible because they are located within the pitch of the roller elements. Pressure damage caused by stationary overloading or by equipment vibrations when transporting over long distances, e.g. during shipping, also present a danger.

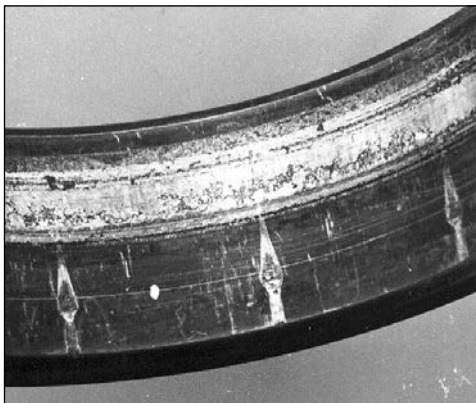

Fig. 11.5

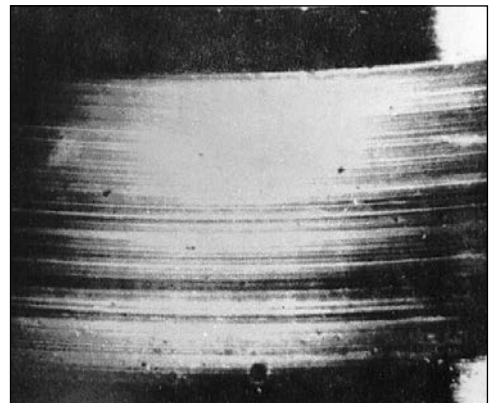

Fig. 11.6

Abrasion

Ball glazing due to overloading and lubrication failures (fig. 11.7) and abrasion of the race due to spinning within the seat (fig. 11.8). The condition in both cases is unacceptable.

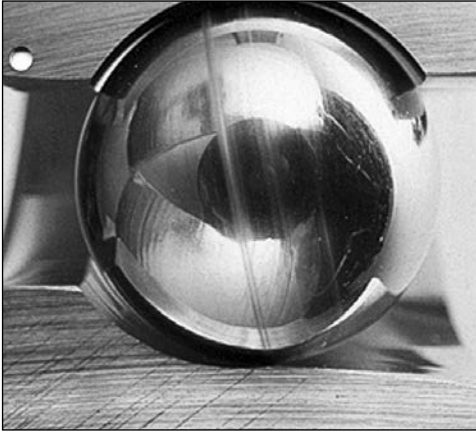

Fig. 11.7



Fig. 11.8

The formation of grooves and craters due to the passage of electric current

Damage to the ball (fig. 11.9) and the raceway (fig. 11.10) by the passage of electric current through the roller contact. This type of damage is unacceptable. This forms when sparking occurs over a thin layer of lubricant. Burned-out cratering forms on such sites and are a source of bearing vibration and increased noise. This type of damage in motor housings and other roller-contact seats of rail vehicles with electrical traction are prevent, for example, by the use of bearings with an insulation layer on one of the rings and by the use of hybrid bearings with ceramic balls.

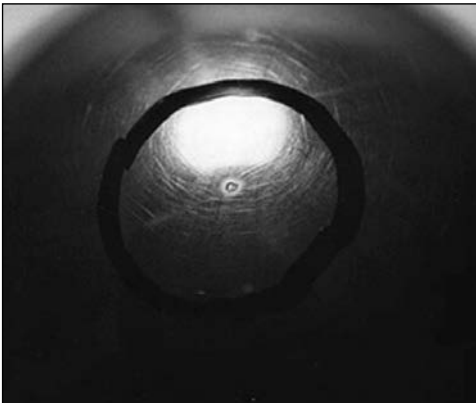

Fig. 11.9

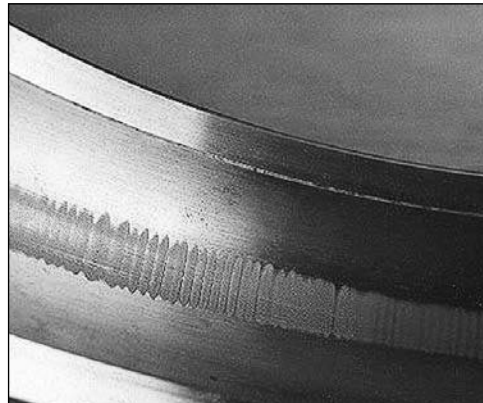

Fig. 11.10

Wear

Wear on the rolling surfaces of cylindrical rollers (fig. 11.11) and races (fig. 11.12) are caused by lubrication failure without flaking of material. Such damage may occur primarily in areas, where maintenance of the lubricating film is hindered, such as bearing ring faces or on roller faces. Undesirable wear may also occur due to slippage of rolling elements towards the bearing rings. Wear is characterized by traces of seizing and slippage, which is often accompanied by brownish spots on the raceway. This is unacceptable wear.

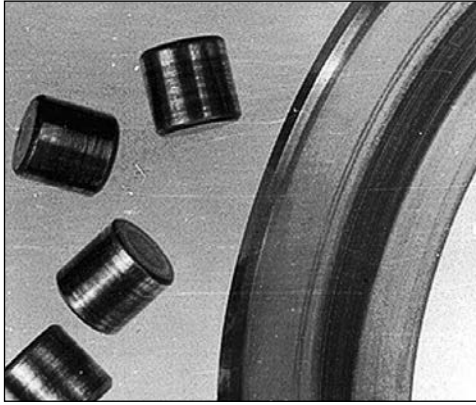

Fig. 11.11

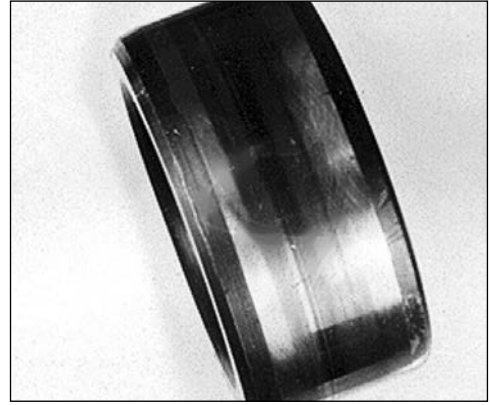

Fig. 11.12

Corrosion

The first picture (fig. 11.13) shows traces of acceptable contact corrosion on the raceway and the second (fig. 11.14) show inner ring corrosion. Corrosion resulting from inadequate protection against moisture or the use of an unsuitable lubricant is always impermissible. Areas affected by rust formation may progressively become initial sites of flaking of operating surfaces, which can lead to deteriorated operating precision and decreased bearing durability. Corrosion occurs when atmospheric moisture condenses, which can occur under improper

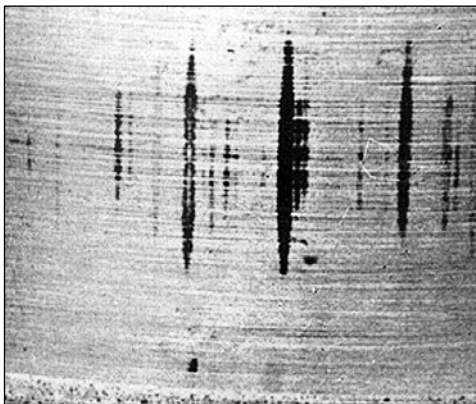

Fig. 11.13

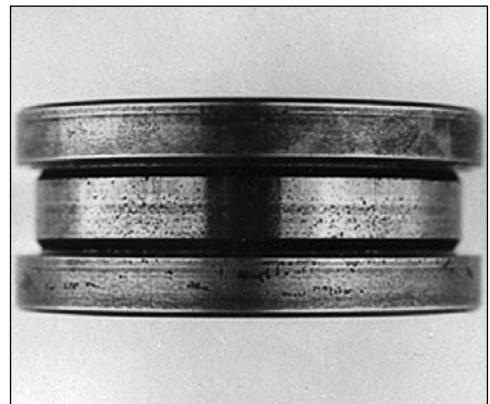

Fig. 11.14

storage conditions. Contact corrosion is caused by very weak oscillations or vibrations of loose components, which can lead to serious bearing damage and thus prevent their further use.

Cage damage

Under normal operating conditions, the roller bearing cage is stressed little. Damage primarily occurs due to poor lubrication. When lubrication is inadequate, cage wear first occurs on the surfaces in contact with rolling elements or with guiding surfaces of bearing rings. The first picture (fig. 11.15) shows deep cage pocket wear from contact with the cylindrical roller with traces of flaked material. This extent of damage is impermissible. The second picture (fig. 11.16) shows permissible glazing of the guide diameter of the solid bronze ball bearing cage.

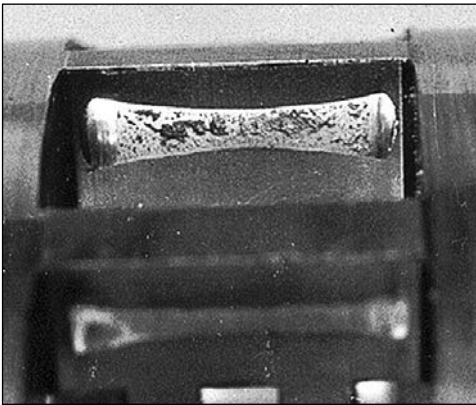

Fig. 11.15



Fig. 11.16



12. PRODUCT DATA – CONTENT

Content

12.	PRODUCT DATA – CONTENT	159
12.1	SINGLE ROW BALL BEARINGS	163
	Single row ball bearings $d = 2$ to 1060 mm	170
	Single Row Ball Bearings with Seals or Shields $d = 3$ to 160 mm	190
	Single row ball bearings with groove for snap ring on outer race $d = 12$ to 120 mm	210
	Separable single row ball bearings $d = 10$ to 20 mm	216
12.2	ANGULAR CONTACT BALL BEARINGS	221
	Single row angular contact ball bearings $d = 10$ to 240 mm	232
	Single row high-speed angular contact ball bearings $d = 7$ to 130 mm	238
	Double row angular contact ball bearings $d = 10$ to 110 mm	252
	Four-point contact bearings $d = 15$ to 200 mm	256
12.3	DOUBLE ROW SELF ALIGNING BALL BEARINGS	263
	Double row self aligning ball bearings $d = 10$ to 150 mm	270
12.4	CYLINDRICAL ROLLER BEARINGS	279
	Single row cylindrical roller bearings $d = 20$ to 1180 mm	290
	Double row cylindrical roller bearings $d = 25$ to 1000 mm	334
	Single row full complement cylindrical roller bearings $d = 20$ to 1000 mm	356
	Double row full complement cylindrical roller bearings $d = 20$ to 400 mm	368
12.5	SPHERICAL ROLLER BEARINGS	381
	Double row spherical roller bearings $d = 25$ to 1120 mm	390
12.6	TAPERED ROLLER BEARINGS	419
	Single row tapered roller bearings in metric dimensions $d = 15$ to 320 mm	426
	Single row tapered roller bearings in inch dimensions $d = 15.875$ to 146.05 mm	440
	Four-row tapered roller bearings $d = 160$ to 630 mm	454
12.7	THRUST BALL BEARINGS	459
	Single direction thrust ball bearings $d = 160$ to 630 mm	464
	Double direction thrust ball bearings $d = 10$ to 140 mm	474
	Thrust ball bearings with sphered housing washer $d = 15$ to 130 mm	478
	Double direction thrust ball bearings with sphered housing washers $d = 25$ to 70 mm	482
12.8	CYLINDRICAL ROLLER THRUST BEARINGS	487
	Cylindrical roller thrust bearings $d = 15$ to 630 mm	494

12.9 SPHERICAL ROLLER THRUST BEARINGS	503
Spherical roller thrust bearings d = 50 to 1120 mm	508
12.10 SPLIT ROLLER BEARINGS	521
Split cylindrical roller bearings d = 150 to 600 mm	528
12.11 BEARINGS FOR RAILWAY APPLICATIONS	537
Single row ball bearings for traction motors d = 65 to 150 mm	542
Single row cylindrical roller bearings for traction motors d = 35 to 150 mm	544
Special single row rolling bearings for railway vehicle axles d = 118 to 130 mm	548
Double row spherical roller bearings for railway vehicle axles d = 100 to 190 mm	550
Tapered bearing units TBU	552
12.12 SPECIAL ROLLER BEARINGS	557
Hybrid ball bearings d = 10 to 120 mm	564
Electrically insulated ball bearings d = 70 to 150 mm	568
Electrically insulated cylindrical roller bearings d = 70 to 150 mm	570
Double row spherical roller bearing PLC 58-11; PLC 58-9-1	574
Double row spherical roller bearing PLC 010-3	574
Single row ball bearing PLC 010-3	575
Double row spherical roller bearings PLC 59-10; PLC 511-14	576
Double row spherical roller bearing PLC 58-2	578
Single row ball bearing KL 761	578
Double row spherical roller bearings PLC 58-6; PLC 59-5; PLC 512-5	580
Double row spherical roller bearings PLC 59-7; PLC 510-9; PLC 510-20	582
Special double row ball bearings PLC 77-1; PLC 14-28; PLC 14-29	584
Single row ball bearings PLC 03-29; PLC 03-33; PLC 03-79	586
Special thrust ball bearings 511Z30; PLC 23-4; PLC 23-5; 511Z35; PLC 24-2; PLC 24-4; PLC 24-5; PLC 24-6; PLC 23-7	588
Special double row angular contact ball bearings PLC 15-2; PLC 14-26; PLC 14-25; PLC 14-24; PLC 15-22; PLC 15-12	590
12.13 BEARING HOUSINGS AND ACCESSORIES	595
Adapter sleeves d = 20 to 150 mm	602
Withdrawal sleeve d = 35 to 180 mm	624
Adapter and withdrawal round nuts	640
Safety mats d = 10 to 200 mm	644
Snap rings for roller bearings with a groove on the outer ring	648
Clamp bearings d = 20 to 40 mm	652
Upright location units with clamp ring d = 25 to 40 mm	654
Four row flanged location units with clamp ring d = 25 to 40 mm	656
Oval shaped flanged location units with clamp ring d = 25 to 40 mm	658
Triangular pressed flanged location units with clamp bearing	660
Round pressed flanged location units with clamp bearing d = 20 to 35 mm	662
Upright sheet metal location units with clamp bearing d = 25 to 35 mm	664



ZKL

GK



12.1 SINGLE ROW BALL BEARINGS

Due to the versatility of applications, single row ball bearings are among the most frequently used types of rolling bearings. They are made as non-separable without a filling slot. Simple design predetermines them for a wide range of operating conditions. They are provided with deep grooves in rings, diameters of which are just a little bigger than those of balls. Due to big ball diameters and high attachment, single row ball bearings feature relatively high dynamic load capacity in both radial and axial directions. Therefore they suit well combined load in both directions. In order to capture axial forces in high revolutions they conveniently substitute axial ball bearings.

ZKL offer single row ball bearings in many designs and sizes. The chart part of the catalogue states the standard assortment of bearings with parameters divided as follows:

- Uncovered bearings in standard version
- Bearings with shields and seals
- Bearings with snap ring groove
- Separable E and BO type bearings.

Main dimensions

With the exception of E and BO type separable single row ball bearings, main dimensions comply with the standard ISO 15. Dimensions of grooves for snap rings comply with the ISO 464 standard.

Uncovered bearings in standard version

The ZKL single row ball bearings in standard version are uncovered and without seals. For manufacturing reasons, also bearings with grooves for shields or seals may get among the standard version of these bearings. Use of these bearings does not require any special provisions.

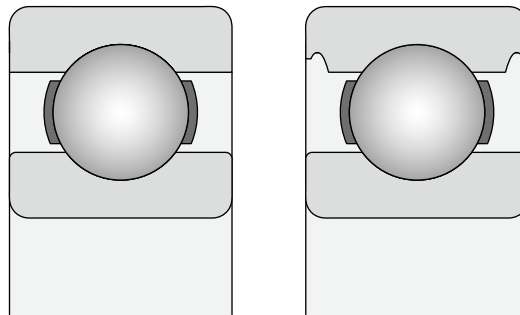

Fig. 12.1.1

Bearings with shields and seals

Part of the ball bearing assortment is produced as non-separable bearings with cover sheets, or with contact seal on one or both sides. Chart No.12.1 shows detail information about the suitability of individual seal types for different conditions. See chapter 7.5 for additional information.

Depending on the design series and size, bearings are supplied filled with standard grease. The standard grease used is not stated in the bearing identification. Grease fills about 25 to 35 % of the free bearing space. Supply of bearings with other than grease has to be agreed with ZKL.

Tab. 12.1.1

instructions for selection of sealing			
Requirement	Shields	Contact seal	
	Z	RS	RSR
Low friction	+++	o	o
High revolutions	+++	o	o
Retention of plastic lubricant	o	+++	++
Against dust penetration	o	+++	+++
Against water penetration			
Static	-	+++	++
dynamic	-	+	+
high pressure	-	+++	o

Symbols: +++ excellent | ++ very good | + good | o sufficient | unsuitable

Bearings with shields

Single row ball bearings with cover sheets have an additional identification Z, ZZ, ZR or ZZR (see fig. 12.1.2). Covered bearings are mostly used to be seated with rotary inner ring. Rotation of outer ring represents a risk of leak of grease in higher revolutions. Cover sheets are made of steel plate. They are seated firmly in outer ring. In Z or ZZ version, cover sheet is embedded in the inner ring recess; ZR or ZZR variants have cover sheet overlapping a bit above the edge of the inner ring.

Bearings with contact seals

Bearings with contact seal (see fig. 12.1.3) are designated by RS, ZRS, RSR or ZRSR identification, depending on the design series and size of the bearing. Seals are pressed in the outer ring recess, and ensure reliable sealing in given position, without outer ring deformation. In extreme conditions, e.g. at high temperatures or revolutions, grease on inner ring might leak. In locations where such lubricant leak is undesirable, different design solution has to be chosen. In these cases we recommend that you contact the ZKL technical and consultancy services.

Bearings versions with additional identification RS or ZRS are provided with a seal the tip of which leans on the recess on the inner ring front. The RSR or ZRSR versions have seals the tip of which leans on the cylindrical surface of the inner ring flange.

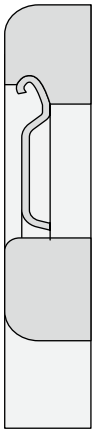
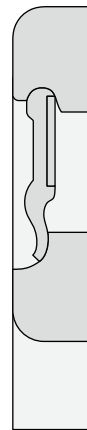
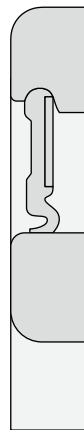

Fig. 12.1.2



Fig. 12.1.3



Bearings with snap ring groove

Single row ball bearings with a groove for snap ring on outer ring serve simple protection against axial displacement in the location element. This design has additional designation N. If bearing is supplied with added snap ring, it is identified with NR. Bearings with snap ring groove can be delivered also in combination with mounted covers.

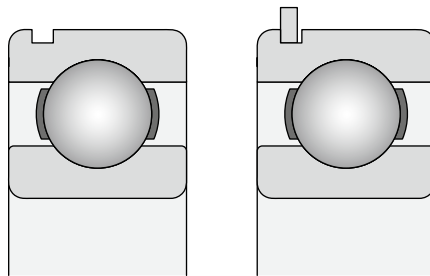

Fig. 12.1.4

Separable bearings

Outer ring of separable single row ball bearings of E and BO type is designed so as to allow separable mounting of inner ring with cage and rolling elements. Bearings are made up to the bore diameter of $d = 20$ mm, and are suitable for lower load and fast running applications.



Accuracy

Single row ball bearings are made in normal accuracy level P0 whilst this symbol is not presented. The accuracy of dimensions and run comply with the standard ISO 492. Exception is only separable single row ball bearings of E and B0 type where the outer diameter has limit deviation of +0.01/0.00 mm. Limit tolerance values are stated in charts 7.2 and 7.3. Limit tolerance values for bearings of higher accuracies are stated in charts 7.4 to 7.8. Limit tolerance values of installation fillet are stated in chart 7.1. These values comply with the standard ISO 582.

Radial clearance

As standard, single row ball bearings are supplied with normal radial clearance. Majority of bearings are also supplied with bigger radial clearance C3. Some bearings can be also offered with a substantially bigger clearance C4 or C5, or with smaller clearance C2. Sizes of radial clearances comply with the standard ISO 5753. The values are stated in chart 7.17a. The stated values apply to non-mounted bearings at zero measuring load. Indicative dependence of radial and axial clearance is stated in Fig. 7.4. See chapter 7.2.3 for additional information.

Vibration level

Commonly made single row ball bearings have normal vibration level checked by the manufacturer. Bearings with P5 and higher accuracy level have reduced vibration level C6. Special cases of location require bearings with specially reduced vibration level C06 and C66.

Tapered bore

For some less demanding locations, some sizes of single row ball bearings of 62 and 63 type with tapered bore and taper ratio 1:12 can be produced. Fixing the bearings onto cylindrical pin is performed using a adapter sleeve or directly on the tapered pin.

Cages

The standard version of single row ball bearings features a cage of steel plate, riveted or pressed, which is guided on balls. Bigger bearing sizes have massive brass cage. Special locations require polyamide cages.

Bearings for locations with high service temperatures

For locations working at service temperature of up to 400 °C we supply single row ball bearings with adequately big radial clearance as per technical conditions agreed between the manufacturer and the customer, and with stabilisation for operation at high temperatures S0 to S5. Stabilisation however reduced the hardness of bearing components and thus also the value of the basic dynamic load capacity, as stated in Tab. 5.9.

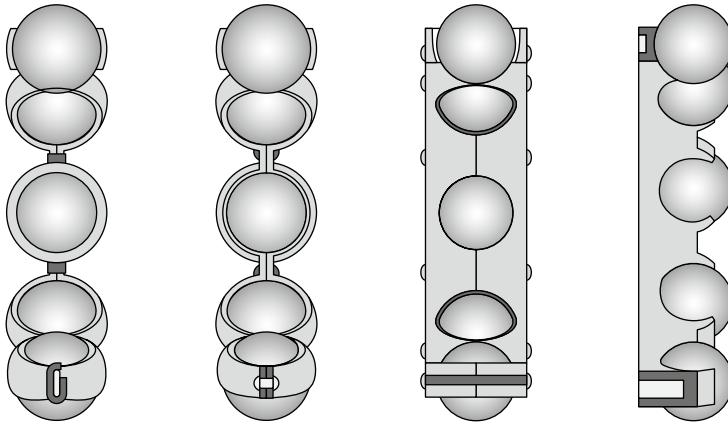

Fig. 12.1.5

Misalignment

Only small mutual tipability of bearing rings is admissible for single row ball bearings, therefore the concentricity deviation of location points can be only very small. The size of it depends on radial clearance in the bearing, its dimensions and load. Misalignment induces additional load of bearing which shortens its service life. Any tilting of bearing rings will also increase the noise level of the bearing.

Tab. 12.1.2

Bearing type	Load	
	low ($F_r < 0,15C_{or}$)	high ($F_r \geq 0,15C_{or}$)
618, 619, 160, 60	2' to 6'	5' to 10'
62, 63, 64	5' to 10'	8' to 16'

Minimum load

Bearings with spot or line contact must be exposed to certain minimum load in order to ensure their proper operation. This applies also to ball bearings working at high revolutions where high acceleration occurs, or in sudden changes of acting load. Insufficient load may cause damage to rolling surfaces and balls due to slip and friction which cause acting of inertial force on the cage and balls. In location with ball bearings axial prestress can be achieved through mutual adjustment of the inner and outer ring against each other, or by means of springs.

The recommended size of minimum load of bearing depending on the dynamic load capacity of it is defined by the below relation:

$$P/C_r > 0.01$$

Axial load capacity

If only axial load acts on ball bearings, it should not exceed $0.5 C_{or}$. Smaller bearings (with bore diameter up to 12 mm) and bearings of light series (diameter of series 8, 9, 0 and 1) should be exposed to axial load of over $0.25 C_{or}$. Excessive axial load may cause substantial shortening of the service life of the bearing.

Equivalent radial load

Single row ball bearings:

$$P_r = F_r \quad \text{for } F_a/F_r \leq e$$

$$P_r = X F_r + Y F_a \quad \text{for } F_a/F_r > e$$

where:

P_r is equivalent radial load [kN]

C_r dynamic load rating of bearing [kN]

C_{or} static load rating of bearing [kN]

F_r radial load

F_a axial load

Values of coefficients e and Y in dependency to the F_a/C_o relation is determined by chart 12.3. Determination of values also depends in the size of radial clearance. Bigger radial clearance allows transferring of bigger axial load. Intermediate values are defined by interpolation.

Tab. 12.1.3

Radial clearance															
F_a/C_{or}	normal					C3					C4				
	$F_a/F_r \leq e$		$F_a/F_r > e$			$F_a/F_r \leq e$		$F_a/F_r > e$			$F_a/F_r \leq e$		$F_a/F_r > e$		
	e	X	Y	X	Y	e	X	Y	X	Y	e	X	Y	X	Y
0,025	0,22	1	0	0,56	2	0,31	1	0	0,46	1,75	0,4	1	0	0,44	1,42
0,04	0,24	1	0	0,56	1,8	0,33	1	0	0,46	1,62	0,42	1	0	0,44	1,36
0,07	0,27	1	0	0,56	1,6	0,36	1	0	0,46	1,46	0,44	1	0	0,44	1,27
0,13	0,31	1	0	0,56	1,4	0,41	1	0	0,46	1,3	0,48	1	0	0,44	1,16
0,25	0,37	1	0	0,56	1,2	0,46	1	0	0,46	1,14	0,53	1	0	0,44	1,05
0,5	0,44	1	0	0,56	1	0,54	1	0	0,46	1	0,56	1	0	0,44	1

Values of coefficients X and Y apply on condition that bearings will be on pin and in body located within the tolerances recommended for low and medium load (Tab. 8.3) and that during the operation no significant decrease of radial clearance occurs due to service temperature (the temperature difference between the inner and outer ring of max 10 °C).

Separable single row ball bearings:

$$P_r = F_r \quad \text{for } F_a/F_r \leq 0.2$$

$$P_r = 0.5 F_r + 2.5 F_a \quad \text{for } F_a/F_r > 0.2$$

Radial equivalent static load

Single row ball bearings:

$$P_{or} = 0.6 F_r + 0.5 F_a \quad [P_{or} \geq F_r]$$

$$P_{or} = F_r \quad [P_{or} < F_r]$$

Separable single row ball bearings:

$$P_{or} = 0.9 F_r + 0.3 F_a \quad [P_{or} \geq F_r]$$

$$P_{or} = F_r \quad [P_{or} < F_r]$$

Single row ball bearings d = 2 to 1060 mm

d = 2 to 10 mm

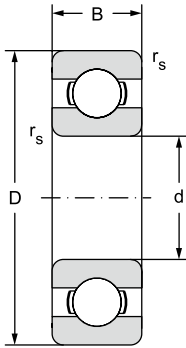

12.1.1

Main dimensions				Basic load rating		Fatigue load limit
d	D	B	r _s	Dynamic C _r	Static C _{or}	P _u
mm				kN		kN
2	6	2,3	0,1	0,279	0,09	0,004
3	10	4	0,15	0,645	0,229	0,01
4	9	2,5	0,2	0,54	0,18	0,007
	11	4	0,2	0,715	0,232	0,01
	12	4	0,2	0,806	0,28	0,012
	13	5	0,2	1,168	0,412	0,019
5	16	5	0,3	1,875	0,677	0,031
	11	3	0,15	0,637	0,255	0,011
	13	4	0,2	1,079	0,432	0,02
	16	5	0,3	1,875	0,677	0,031
6	19	6	0,3	2,838	1,078	0,049
	13	3,5	0,15	0,884	0,345	0,015
	15	5	0,2	1,47	0,599	0,027
7	19	6	0,3	2,838	1,078	0,049
	14	3,5	0,15	0,956	0,4	0,017
	17	5	0,3	1,48	0,56	0,024
8	22	7	0,3	3,282	1,356	0,062
	16	4	0,2	1,55	0,722	0,033
	19	6	0,2	1,9	0,735	0,031
	22	7	0,3	3,282	1,356	0,062
9	24	8	0,3	3,9	1,66	0,071
	17	4	0,2	1,43	0,64	0,027
	20	6	0,3	2,08	0,865	0,036
	24	7	0,3	3,668	1,64	0,075
10	26	8	0,3	4,557	1,955	0,089
	19	5	0,3	1,38	0,585	0,025
	22	6	0,3	2,08	0,85	0,036
	26	8	0,3	4,557	1,955	0,089
	28	8	0,6	4,62	1,96	0,083
30	30	9	0,6	6,047	2,51	0,114
	30	14	0,6	6,047	2,51	0,114
	35	11	0,6	8,072	3,43	0,156
	30	9	0,6	6,047	2,51	0,114

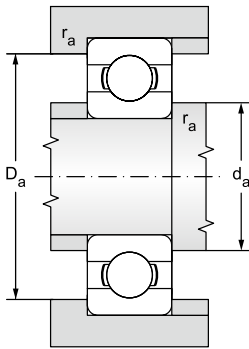

Limiting speed for lubrication with		Bearing designation	Abutment and Fillet Dimensions			Weight
Grease	Oil		d_a	D_a	r_a	~
			min	max	max	
min^{-1}			mm			kg
63000	79000	619/2	3,2	4,8	0,1	0,0004
40000	50000	623	4,2	8,5	0,1	0,0015
63000	75000	618/4	4,6	8,4	0,1	0,0007
60000	71000	619/4	4,8	10,2	0,1	0,0017
53000	63000	604	5,4	10,6	0,2	0,0021
38000	45000	624	5,6	11,2	0,2	0,0032
35000	42000	634	6,2	13,4	0,3	0,0050
53000	63000	618/5	5,8	10,2	0,1	0,0012
47000	56000	619/5	6,6	11,5	0,2	0,0025
35000	42000	625	7	14	0,3	0,0047
35000	42000	635	7,2	15,8	0,3	0,0090
48000	56000	618/6	6,8	12,2	0,1	0,0020
42000	50000	619/6	7,8	13	0,2	0,0040
35000	42000	626	8,2	17	0,3	0,0080
44000	51000	618/7	7,8	13,2	0,1	0,0022
41000	47000	619/7	9	15	0,3	0,0049
35000	42000	607	9	17,2	0,3	0,0090
35000	42000	627	9,2	19	0,3	0,012
35000	42000	618/8TNH	9,8	14	0,2	0,0030
39000	46000	619/8	10	17	0,3	0,0071
35000	42000	608	10	20	0,3	0,015
31000	36000	628	10,4	21,6	0,3	0,017
38000	45000	618/9	10,4	15,6	0,2	0,0034
37000	44000	619/9	11	18	0,3	0,0076
35000	42000	609	11	22	0,3	0,018
35000	42000	629	11	24	0,3	0,020
36000	43000	61800	12	17	0,3	0,0055
34000	40000	61900	12	20	0,3	0,0100
28000	33000	6000	12	24	0,3	0,019
28000	34000	16100	14,2	23,8	0,3	0,022
25000	30000	6200	14	26	0,6	0,031
25000	30000	62200	14	26	0,6	0,040
22000	27000	6300	14	31	0,6	0,054

Single row ball bearings

d = 12 to 20 mm

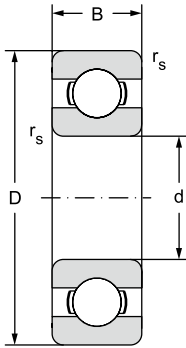

12.1.1	Main dimensions				Basic load rating		Fatigue load limit
	d	D	B	r _s	Dynamic C _r	Static C _{0r}	P _u
	mm				kN		kN
12	21	21	5	0,3	1,43	0,67	0,028
		24	6	0,3	2,25	0,98	0,043
		28	7	0,3	5,094	2,36	0,107
		28	8	0,3	5,094	2,36	0,107
		30	8	0,3	5,07	2,36	0,1
		32	10	0,6	6,905	3,1	0,141
		32	14	0,6	6,905	3,1	0,141
		37	12	1	9,759	4,235	0,193
15	24	24	5	0,3	1,56	0,8	0,034
		28	7	0,3	4,36	2,24	0,095
		32	8	0,3	5,594	2,86	0,13
		32	9	0,3	5,594	2,865	0,13
		35	11	0,6	7,718	3,745	0,17
		35	14	0,6	7,718	3,745	0,17
		42	13	1	11,31	5,33	0,242
17	26	26	5	0,3	1,68	0,93	0,039
		30	7	0,3	4,62	2,55	0,108
		35	8	0,3	5,999	3,265	0,148
		35	10	0,3	6,001	3,267	0,149
		40	12	0,6	9,534	4,734	0,215
		40	16	0,6	9,534	4,734	0,215
		47	14	1	13,565	6,56	0,298
		62	17	1,1	22,9	10,8	0,455
20	32	32	7	0,3	4,03	2,32	0,104
		37	9	0,3	6,37	3,65	0,156
		42	8	0,3	9,371	4,972	0,226
		42	12	0,6	9,371	4,972	0,226
		47	14	1	12,774	6,553	0,298
		47	18	1	12,774	6,553	0,298
		47	20,6	1	12,774	6,553	0,298
		52	15	1,1	15,866	7,811	0,355
		72	19	0,6	30,7	15	0,64
		52	21	1,1	15,866	7,811	0,355

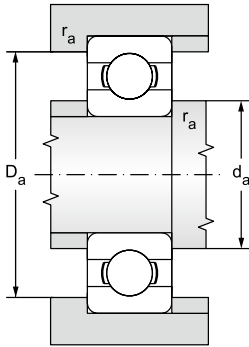

Limiting speed for lubrication with		Bearing designation	Abutment and Fillet Dimensions			Weight
Grease	Oil		d_a	D_a	r_a	~
			min	max	max	
min^{-1}			mm			kg
32000	38000	61801	14	19	0,3	0,0063
30000	36000	61901	14	22	0,3	0,011
25000	30000	16001	14	26	0,3	0,020
25000	30000	6001	14	26	0,3	0,022
26000	32000	16101	14,4	27,6	0,3	0,023
22000	27000	6201	16	28	0,6	0,037
22000	27000	62201	16	28	0,6	0,045
20000	24000	6301	17	32	1	0,061
28000	34000	61802	17	22	0,3	0,0074
24000	30000	61902	17	26	0,3	0,016
21000	25000	16002	17	30	0,3	0,027
21000	25000	6002	17	30	0,3	0,030
20000	24000	6202	19	31	0,6	0,046
20000	24000	62202	19	31	0,6	0,054
18000	21000	6302	20	36	1	0,085
24000	30000	61803	19	24	0,3	0,0082
22000	28000	61903	19	28	0,3	0,018
20000	24000	16003	19	33	0,3	0,032
20000	24000	6003	19	33	0,3	0,040
18000	21000	6203	21	36	0,6	0,073
18000	21000	62203	21	36	0,6	0,083
16000	19000	6303	23	41	1	0,12
12000	15000	6403	23,5	55,5	1	0,27
19000	24000	61804	22	30	0,3	0,018
18000	22000	61904	22	35	0,3	0,038
17000	20000	16004D	22	40	0,3	0,050
17000	20000	6004	24	38	0,6	0,070
15000	18000	6204	25	42	1	0,11
15000	18000	62204	25	42	1	0,13
15000	18000	63204	25	42	1	0,15
14000	17000	6304	26	45	1	0,15
10000	13000	6404	29	63	1	0,40
14000	17000	62304	26	45	1	0,20

Single row ball bearings

d = 25 to 40 mm

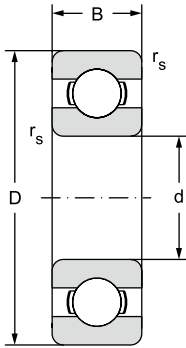

12.1.1

Main dimensions				Basic load rating		Fatigue load limit
d	D	B	r _s	Dynamic C _r	Static C _{or}	P _u
mm				kN		kN
25	37	7	0,3	4,36	2,6	0,125
	42	9	0,3	7,02	4,3	0,193
	47	8	0,3	6,95	4,55	0,207
	47	8	0,3	10,07	5,806	0,264
	47	12	0,6	10,07	5,806	0,264
	52	15	1	14,029	7,94	0,361
	52	18	1	14,029	7,94	0,361
	62	17	1,1	21,123	10,806	0,491
	62	24	1,1	21,123	10,806	0,491
	80	21	1,5	36	19,2	0,873
30	42	7	0,3	4,49	2,9	0,146
	47	9	0,3	7,28	4,55	0,212
	55	9	0,3	11,2	7,36	0,335
	55	13	1	13,243	8,25	0,375
	62	16	1	19,443	11,186	0,508
	62	20	1	19,443	11,186	0,508
	72	19	1,1	29,701	15,678	0,713
	90	23	1,5	43	23,7	1,077
35	47	7	0,3	4,75	3,2	0,17
	55	10	0,6	9,56	6,8	0,29
	62	9	0,3	9,96	7,362	0,335
	62	14	1	15,956	10,328	0,469
	72	17	1,1	25,663	15,227	0,692
	80	21	1,5	33,367	19,23	0,874
	100	25	1,5	55,2	31	1,409
40	52	7	0,3	4,94	3,45	0,19
	62	12	0,6	13,8	10	0,43
	68	9	0,3	12,667	9,617	0,437
	68	15	1	16,824	11,493	0,522
	80	18	1,1	32,633	19,887	0,904
	80	18	1,1	35,8	20,8	0,88
	90	23	1,5	40,76	24,17	1,099
	110	27	2	63,1	36,2	1,645

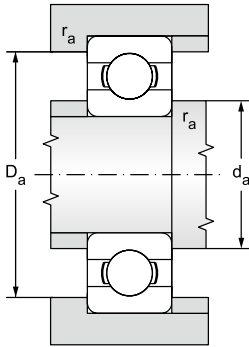

Limiting speed for lubrication with		Bearing designation	Abutment and Fillet Dimensions			Weight
Grease	Oil		d_a	D_a	r_a	
			min	max	max	~
min^{-1}			mm			kg
17000	20000	61805	27	35	0,3	0,022
16000	19000	61905	27	40	0,3	0,045
14000	17000	16005	27	43	0,3	0,053
14000	17000	16005D	27	43	0,3	0,053
14000	17000	6005	28	43	0,6	0,082
12000	15000	6205	30	47	1	0,13
12600	15000	62205	30	47	1	0,15
11000	13000	6305	31	55	1	0,23
11000	13000	62305	31	55	1	0,32
9400	11000	6405	34	70	1,5	0,53
15000	18000	61806	32	40	0,3	0,027
14000	17000	61906	32	45	0,3	0,051
12000	14000	16006	32	53	0,3	0,087
12000	14000	6006	34	50	1	0,12
11000	13000	6206	35	57	1	0,20
11000	13000	62206	35	57	1	0,24
10000	12000	6306	36	65	1	0,33
8400	10000	6406	39	80	1,5	0,73
13000	16000	61807	37	45	0,3	0,030
11000	14000	61907	38,2	51,8	0,6	0,080
10600	12600	16007	37	60	0,3	0,11
10600	12600	6007	39,5	57	1	0,15
9400	11000	6207	42	65	1	0,28
8400	10000	6307	42	71	1,5	0,45
7500	8900	6407	44	90	1,5	0,95
11000	14000	61808	42	50	0,3	0,034
10000	13000	61908	43,2	58,8	0,6	0,12
9400	11000	16008	42	62	0,3	0,13
9400	11000	6008	44	63	1	0,19
8400	10000	6208	47	73	1	0,35
8500	10000	6208	47	73	1	0,34
7900	9400	6308	47	81	1,5	0,63
6700	7900	6408	50	97	2	1,12

Single row ball bearings

d = 45 to 65 mm

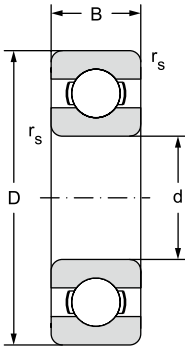

12.1.1

Main dimensions				Basic load rating		Fatigue load limit
d	D	B	r _s	Dynamic C _r	Static C _{or}	P _u
mm				kN		kN
45	58	7	0,3	6,63	6,1	0,26
	68	12	0,6	14	10,8	0,47
	75	10	0,6	15,659	12,172	0,553
	75	16	1	21,1	15,3	0,695
	85	19	1,1	32,678	20,325	0,924
	100	25	1,5	52,804	31,715	1,442
50	120	29	2	76,5	44,7	2,032
	65	7	0,3	6,76	6,8	0,285
	72	12	0,6	14,6	11,8	0,5
	80	10	0,6	16,092	13,147	0,598
	80	16	1	21,72	16,65	0,757
	90	20	1,1	35,066	23,226	1,056
55	110	27	2	61,754	37,754	1,716
	130	31	2,1	87,4	52,1	2,368
	72	9	0,3	9,04	8,8	0,38
	80	13	1	16,5	14	0,6
	90	11	0,6	20,3	14	0,7
	90	18	1,1	28,216	21,318	0,969
60	100	21	1,5	43,35	29,397	1,336
	120	29	2	71	44,7	2,032
	140	33	2,1	100	61,9	2,814
	78	10	0,3	11,9	11,4	0,49
	85	13	1	16,5	14,3	0,6
	95	11	0,6	20,8	15	0,74
65	95	18	1,1	29,343	23,256	1,057
	110	22	1,5	52,846	35,786	1,627
	130	31	2,1	81,5	52,1	2,368
	150	35	2,1	110	69,4	3,079
	85	10	0,6	12,4	12,7	0,54
	90	13	1	17,4	16	0,68
100	100	11	0,6	21,2	19,6	0,891
	100	18	1,1	30,5	25,1	1,141
	120	23	1,5	57,21	40,011	1,819
	140	33	2,1	92,6	59,6	2,676
	160	37	2,1	117,95	78,329	3,357

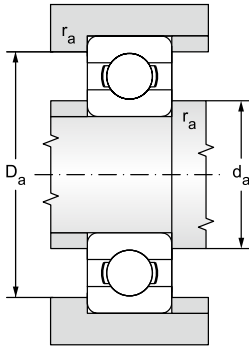

Limiting speed for lubrication with		Bearing designation	Abutment and Fillet Dimensions			Weight
Grease	Oil		d_a	D_a	r_a	
			min	max	max	~
min^{-1}			mm			kg
9500	12000	61809	47	56	0,3	0,040
9000	11000	61909	48,2	64,8	0,6	0,14
8400	10000	16009	49	71	1	0,17
8400	10000	6009	49	70	1	0,24
7900	9400	6209	52	78	1	0,40
7100	8400	6309	52	91	1,5	0,83
6000	7100	6409	55	107	2	1,54
9000	11000	61810	52	63	0,3	0,052
8500	10000	61910	53,2	68,8	0,6	0,14
7900	9400	16010	54	76	0,6	0,19
7900	9400	6010	54	75	1	0,26
7100	8400	6210	57	83	1	0,46
6300	7500	6310	60	100	2	1,06
5600	6700	6410	63	116	2	1,89
8500	10000	61811	57	70	0,3	0,083
8000	9500	61911	59,6	75,4	1	0,19
7500	9000	16011	58,2	86,8	0,6	0,26
7100	8400	6011	60	84	1	0,38
6700	7900	6211	62	91	1,5	0,60
5600	6700	6311	65	110	2	1,38
5300	6300	6411	68	126	2	2,29
7500	9000	61812	62	76	0,3	0,11
7500	9000	61912	64,6	80,4	1	0,20
6700	8000	16012	63,2	91,8	0,6	0,28
6700	7900	6012	65	88	1	0,41
6000	7100	6212	67	101	1,5	0,77
5300	6300	6312	72	118	2	1,72
4700	5600	6412	73	136	2	2,76
7000	8500	61813	68,2	81,8	0,6	0,13
6700	8000	61913	69,6	85,4	1	0,22
6300	7500	16013	69	96	0,6	0,30
6300	7500	6013	70	93	1	0,44
5300	6300	6213	72	111	1,5	1,00
5000	6000	6313	76	128	2	2,10
4500	5300	6413	78	146	2	3,28

Single row ball bearings

d = 70 to 90 mm

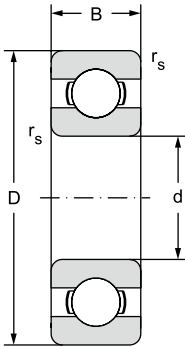

12.1.1	Main dimensions				Basic load rating		Fatigue load limit
	d	D	B	r _s	Dynamic C _r	Static C _{0r}	P _u
	mm				kN		kN
70	90	10	0,6	12,4	13,2	0,56	
	100	16	1	23,8	21,2	0,9	
	110	13	0,6	27,6	25,1	1,141	
	110	20	1,1	37,96	30,959	1,407	
	125	24	1,5	62	43,8	1,991	
	150	35	2,1	104	63,1	2,735	
	180	42	3	144	104	4,228	
75	95	10	0,6	12,7	14,3	0,61	
	105	16	1	24,2	19,3	0,965	
	110	12	0,6	28,6	27	1,14	
	115	13	0,6	28,7	26,6	1,209	
	115	20	1,1	39,747	33,17	1,508	
	130	25	1,5	66,179	49,311	2,214	
	160	37	2,1	114	76,4	3,204	
190	45	3	152,525	112,922	4,459		
80	100	10	0,6	13	15	0,64	
	110	16	1	25,1	20,4	1,02	
	125	14	0,6	32,9	31,6	1,419	
	125	22	1,1	47,5	39,8	1,787	
	140	26	2	72,2	53,1	2,301	
	170	37	2,1	122,85	86,226	3,506	
	200	48	3	163,587	124,984	4,801	
85	110	13	1	19,5	20,8	0,88	
	120	18	1,1	31,9	30	1,25	
	130	14	0,6	34,1	32,9	1,442	
	130	22	1,1	49,794	42,609	1,868	
	150	28	2	83,299	63,675	2,67	
	180	41	3	132,507	96,069	3,794	
	210	52	4	174	136	5,09	
90	115	13	1	19,5	22	0,915	
	125	18	1,1	33,2	31,5	1,23	
	140	16	1	43,6	39	1,56	
	140	24	1,5	58,4	49,2	2,085	
	160	30	2	96,2	70,8	2,878	
	190	43	3	144	108	4,149	
	225	54	4	192	158	5,723	

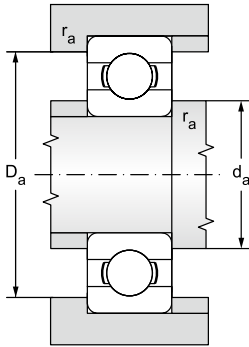

Limiting speed for lubrication with		Bearing designation	Abutment and Fillet Dimensions			Weight
Grease	Oil		d_a	D_a	r_a	
			min	max	max	~
min^{-1}			mm			kg
6700	8000	61814	73,2	86,8	0,6	0,14
6300	7500	61914	74,6	95,4	1	0,35
5600	6700	16014	74	106	0,6	0,43
5600	6700	6014	75	103	1	0,60
5300	6300	6214	77	116	1,5	1,07
4700	5600	6314	81	138	2	2,54
4000	4700	6414	85	164	2,5	4,85
6300	7500	61815	78,2	91,8	0,6	0,15
6000	7000	61915	79,6	100	1	0,37
5500	7800	16115	77	108	0,3	0,38
5300	6300	16015	79	111	0,6	0,46
5300	6300	6015	80	108	1	0,64
5000	6000	6215	82	122	1,5	1,18
4200	5000	6315	86	148	2	3,06
3800	4500	6415	90	174	2,5	5,74
6000	7000	61816	83,2	96,8	0,6	0,15
5600	6700	61916	84,6	105	1	0,40
5000	6000	16016	84	121	0,6	0,60
5000	6000	6016	85	118	1	0,85
4700	5600	6216	90	130	2	1,40
4000	4700	6316	91	158	2	3,63
3500	4200	6416	95	184	2,5	6,72
5300	6300	61817	89,6	105	1	0,27
5300	6300	61917	91	114	1	0,55
4700	5600	16017	89	126	0,6	0,63
4700	5600	6017	90	123	1	0,89
4200	5000	6217	95	140	2	1,80
3800	4500	6317	98	166	2,5	4,20
3300	4000	6417	105	190	3	7,88
5300	6300	61818	94,6	110	1	0,28
5000	6000	61918	96	119	1	0,59
4800	5600	16018	94,6	135	1	0,85
4500	5300	6018	96	132	1,5	1,17
4000	4700	6218	100	150	2	2,16
3500	4200	6318	103	176	2,5	4,95
3200	3800	6418	110	205	3	11,4

Single row ball bearings

d = 95 to 130 mm

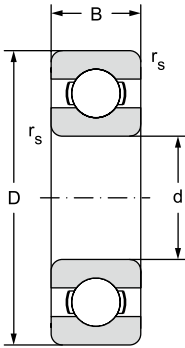

12.1.1

Main dimensions				Basic load rating		Fatigue load limit
d	D	B	r _s	Dynamic C _r	Static C _{0r}	P _u
mm				kN		kN
95	120	13	1	19,9	22,8	0,93
	130	18	1,1	33,8	33,5	1,43
	145	16	1	42,3	41,5	1,722
	145	24	1,5	60,7	54,1	2,245
	170	32	2,1	108	81	3,199
	200	45	3	152,444	117,366	4,393
100	125	13	1	19,9	24	0,95
	140	20	1,1	42,3	41	1,63
	150	16	1	44	43,8	1,781
	150	24	1,5	60,096	54,244	2,205
	180	34	2,1	123	92,6	3,557
	215	47	3	174	141	5,107
105	130	13	1	20,8	19,6	1
	145	20	1,1	44,2	44	1,7
	160	18	1	54	51	1,86
	160	26	2	72,2	65,6	2,59
	190	36	2,1	132,927	104,833	3,924
	225	49	3	185	153	5,414
110	140	16	1	28,1	26	1,25
	150	20	1,1	43,6	45	1,66
	170	19	1	57,6	56,2	2,159
	170	28	2	82,5	72,2	2,774
	200	38	2,1	144	117	4,272
	240	50	3	203	180	6,185
120	150	16	1	29,1	28	1,29
	165	22	1,1	55,3	57	2,04
	180	19	1	61	63,1	2,342
	180	28	2	85	79,4	2,947
	215	40	2,1	144	117	4,109
	260	55	3	208	186	5,7
130	165	18	1,1	37,7	43	1,6
	180	24	1,5	65,503	67,193	2,453
	200	22	1,1	83,2	81,5	2,7
	200	33	2	106,986	99,667	3,527
	230	40	3	153	133	4,506
	280	58	4	229	216	6,3

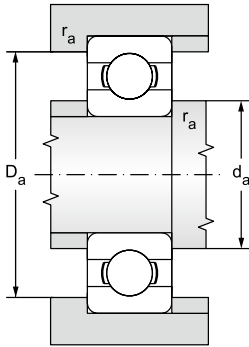

Limiting speed for lubrication with		Bearing designation	Abutment and Fillet Dimensions			Weight
Grease	Oil		d_a	D_a	r_a	~
			min	max	max	
min^{-1}			mm			kg
5000	6000	61819	99,6	115	1	0,30
4800	5600	61919	101	124	1	0,61
4200	5000	16019	100	140	1	0,89
4200	5000	6019	102	137	1,5	1,22
3800	4500	6219	107	158	2	2,60
3300	4000	6319	109	186	2,5	5,72
4800	5600	61820	105	120	1	0,31
4500	5300	61920	106	134	1	0,83
4200	5000	16020	105	145	1	0,91
4200	5000	6020	106	142	1,5	1,27
3500	4200	6220	112	169	2	3,13
3200	3800	6320	113	201	2,5	7,07
4500	5300	61821	110	125	1	0,32
4300	5000	61921	111	139	1	0,87
4000	4800	16021	110	155	1	1,20
4000	4700	6021	113	151	2	1,59
3300	4000	6221	117	178	2	3,74
3000	3500	6321	119	211	2,5	8,00
4300	5000	61822	115	135	1	0,60
4000	4800	61922	116	144	1	0,90
3800	4500	16022	115	165	1	1,46
3800	4500	6022	118	161	2	1,95
3200	3800	6222	122	188	2	4,37
2600	3200	6322	123	227	2,5	9,58
3800	4500	61824	125	145	1	0,65
3600	4300	61924	126	159	1	1,20
3300	4000	16024	125	175	1	1,80
3300	4000	6024	128	171	2	2,10
3000	3500	6224	132	203	2	5,15
2400	3000	6324	134	246	2,5	12,5
3600	4300	61826	136	159	1	0,93
3200	3800	61926	137	172	1	1,86
3200	3800	16026	136	192	1	2,35
3200	3800	6026	138	191	2	3,26
2800	3300	6226	144	216	2,5	6,20
2200	2800	6326M	147	263	3	17,5

Single row ball bearings

d = 140 to 190 mm

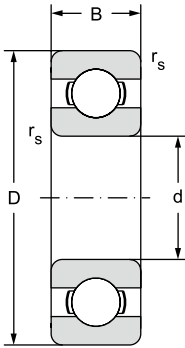

12.1.1

Main dimensions				Basic load rating		Fatigue load limit
d	D	B	r _s	Dynamic C _r	Static C _{or}	P _u
mm				kN		kN
140	175	18	1,1	39	46,5	1,66
	190	24	1,5	66,3	72	2,36
	210	22	1,1	80,6	86,5	2,8
	210	33	2	110	108	3,711
	250	42	3	166	150	4,883
	300	62	4	251	245	7,1
150	190	20	1,1	48,8	61	1,96
	210	28	2	88,4	93	2,9
	225	24	1,1	92,2	98	3,05
	225	35	2,1	126	126	4,183
	270	45	3	190	181	5,677
	320	65	4	276	285	7,8
160	200	20	1,1	49,4	64	2
	220	28	2	92,3	98	3,05
	240	25	1,5	99,5	108	3,25
	240	38	2,1	143	143	4,3
	290	48	3	186	186	5,3
	340	68	4	276	285	7,65
170	215	22	1,1	61,8	78	2,4
	230	28	2	93,6	106	3,15
	260	28	1,5	119	129	3,75
	260	42	2,1	168	171	5,301
	310	52	4	212	224	6,1
	360	72	4	312	340	8,8
180	225	22	1,1	62,4	81,5	2,45
	250	33	2	119	134	3,9
	280	31	2	138	146	4,15
	280	46	2,1	190	200	5,6
	320	52	4	229	240	6,4
	380	75	4	351	405	10,4
190	240	24	1,5	76,1	98	2,8
	260	33	2	117	134	3,8
	290	31	2	148	166	4,55
	290	46	2,1	195	216	5,85
	340	55	4	255	280	7,35
	400	78	5	371	430	10,8

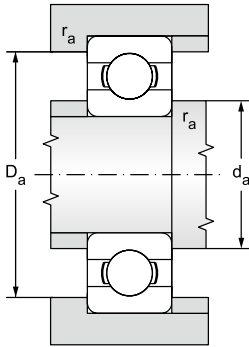

Limiting speed for lubrication with		Bearing designation	Abutment and Fillet Dimensions			Weight
Grease	Oil		d_a	D_a	r_a	
			min	max	max	~
min^{-1}			mm			kg
3400	4000	61828	146	169	1	0,99
3200	3800	61928MA	147	183	1,5	1,70
3000	3600	16028	146	204	1	2,50
3000	3500	6028	148	200	2	3,39
2500	3000	6228	154	236	2,5	7,56
2000	2600	6328M	157	283	3	22,0
3000	3600	61830	156	184	1	1,40
2800	3400	61930MA	159	201	2	3,05
2600	3200	16030	156	219	1	3,15
2700	3200	6030	159	213	2	4,16
2200	2700	6230	164	256	2,5	9,85
1900	2400	6330M	167	303	3	26,0
2800	3400	61832	166	194	1	1,45
2600	3200	61932MA	169	211	2	3,25
2400	3000	16032	167	233	1,5	3,70
2400	3000	6032	169	231	2	5,90
1900	2400	6232	174	276	2,5	14,5
1800	2200	6332M	177	323	3	29,0
2600	3200	61834	176	209	1	1,90
2400	3000	61934MA	179	221	2	3,40
2200	2800	16034	177	253	1,5	5,00
2200	2700	6034	179	248	2	6,91
1900	2400	6234M	187	293	3	17,5
1700	2000	6334M	187	343	3	34,5
2400	3000	61836	186	219	1	2,00
2200	2800	61936MA	189	241	2	5,05
2000	2600	16036	189	271	2	6,60
2000	2600	6036M	190	270	2	10,5
1800	2200	6236M	197	303	3	18,5
1700	2000	6336M	197	363	3	42,5
2200	2800	61838	197	233	1,5	2,60
2200	2800	61938MA	199	251	2	5,25
2000	2600	16038	199	281	2	7,90
2000	2600	6038M	200	280	2	11,0
1700	2000	6238M	207	323	3	23,0
1600	1900	6338M	210	380	4	49,0

Single row ball bearings

d = 200 to 320 mm

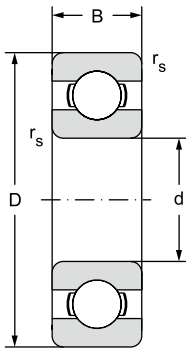

12.1.1

Main dimensions				Basic load rating		Fatigue load limit
d	D	B	r _s	Dynamic C _r	Static C _{0r}	P _u
mm				kN		kN
200	250	24	1,5	76,1	102	2,9
	280	38	2,1	148	166	4,55
	310	34	2	168	190	5,1
	310	51	2,1	216	245	6,4
	360	58	4	270	310	7,8
220	270	24	1,5	78	110	3
	300	38	2,1	151	180	4,75
	340	37	2,12	174	204	5,2
	340	56	3	247	290	7,35
	400	65	4	296	365	8,8
	460	88	5	410	520	12
240	300	28	2	108	150	3,8
	320	38	2,1	159	200	5,1
	360	37	2,1	178	220	5,3
	360	56	3	255	315	7,8
	440	72	4	358	465	10,8
	500	95	5	442	585	12,9
260	320	28	2	111	163	4
	360	46	2,1	212	270	6,55
	400	44	3	238	310	7,2
	400	65	4	291	375	8,8
	480	80	5	390	530	11,8
280	350	33	2	138	200	4,75
	380	46	2,1	216	285	6,7
	420	44	3	242	335	7,5
	420	65	4	302	405	9,3
	500	80	5	423	600	12,9
300	380	38	2,1	172	245	5,6
	420	56	3	270	375	8,3
	460	50	4	286	405	8,8
	460	74	4	358	500	10,8
	540	85	5	462	670	13,7
320	400	38	2,1	172	255	5,7
	440	56	3	276	400	8,65
	480	50	4	281	405	8,65
	480	74	4	371	540	11,4

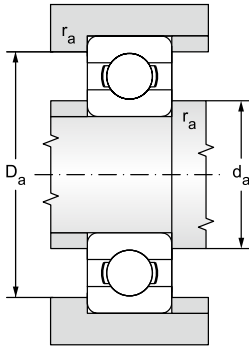

Limiting speed for lubrication with		Bearing designation	Abutment and Fillet Dimensions			Weight	
Grease	Oil		d_a	D_a	r_a		
			min	max	max	~	
min^{-1}			mm			kg	
	2200	2800	61840	207	243	1,5	2,70
	2000	2600	61940MA	210	270	2	7,40
	1900	2400	16040	209	301	2	8,85
	1900	2400	6040M	210	300	2	14,0
	1700	2000	6240M	217	343	3	28,0
	1900	2400	61844	227	263	1,5	3,00
	1900	2400	61944MA	230	290	2	8,00
	1800	2200	16044	230	330	2	11,5
	1800	2200	6044M	233	327	2,5	18,5
	1500	1800	6244M	237	383	3	37,0
	1300	1600	6344M	240	440	4	72,5
	1800	2200	61848	249	291	2	4,50
	1800	2200	61948MA	250	310	2	8,60
	1700	2000	16048MA	250	350	2	14,5
	1700	2000	6048M	253	347	2,5	19,5
	1300	1600	6248M	257	423	3	51,0
	1300	1600	6348M	260	480	4	92,5
	1700	2000	61852	269	311	2	4,80
	1600	1900	61952MA	270	350	2	14,5
	1500	1800	16052MA	273	387	2,5	21,5
	1500	1800	6052M	277	383	3	29,5
	1100	1400	6252M	280	460	4	65,5
	1600	1900	61856	289	341	2	7,40
	1500	1800	61956MA	291	369	2	15,0
	1400	1700	16056MA	293	407	2,5	23,0
	1400	1700	6056M	296	404	3	31,0
	1100	1400	6256M	300	480	4	71,0
	1400	1700	61860MA	309	371	2	10,5
	1300	1600	61960MA	313	407	2,5	24,5
	1200	1500	16060MA	315	445	3	32,0
	1200	1500	6060M	315	445	3	44,0
	1200	1500	6260M	320	520	4	88,5
	1300	1600	61864MA	332	388	2	11,0
	1200	1500	61964MA	333	427	2,5	25,5
	1100	1400	16064MA	335	465	3	34,0
	1100	1400	6064M	335	465	3	46,0

Single row ball bearings

d = 340 to 500 mm

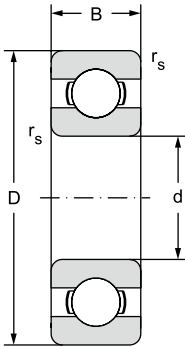

12.1.1

Main dimensions				Basic load rating		Fatigue load limit
d	D	B	r _s	Dynamic C _r	Static C _{0r}	P _u
mm				kN		kN
340	420	38	2,1	178	275	6
	460	56	3	281	425	9
	520	57	4	345	520	10,6
	520	82	5	423	640	13,2
360	440	38	2,1	182	285	6,1
	480	56	3	291	450	9,15
	540	57	4	351	550	11
	540	82	5	462	735	15
380	480	46	2,1	242	390	8
	520	65	4	338	540	10,8
	560	57	4	377	620	12,2
	560	82	5	462	750	14,6
400	500	46	2,1	247	405	8,15
	540	65	4	345	570	11,2
	600	90	5	520	865	16,3
420	520	46	2,1	251	425	8,3
	560	65	4	351	600	11,4
	620	90	5	507	880	16,3
440	540	46	2,1	255	440	8,5
	600	74	4	410	720	13,2
	650	94	6	553	965	17,6
460	580	56	3	319	570	10,6
	620	74	4	423	750	13,7
	680	100	6	582	1060	19
480	600	56	3	325	600	10,8
	650	78	5	449	815	14,6
	700	100	6	618	1140	20
500	620	56	3	332	620	11,2
	670	78	5	462	865	15
	720	100	6	605	1140	19,6

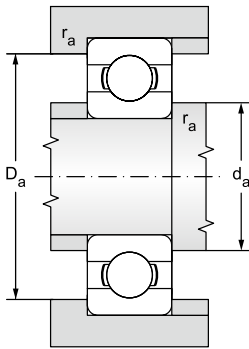

** Bearings in the new standard NEW FORCE

Limiting speed for lubrication with		Bearing designation	Abutment and Fillet Dimensions			Weight
Grease	Oil		d_a	D_a	r_a	
			min	max	max	~
min^{-1}			mm			kg
1200	1500	61868MA	352	408	2	11,5
1100	1400	61968MA	353	447	2,5	26,5
1000	1300	16068MA	355	505	3	45,0
1000	1300	6068M	360	500	4	62,0
1100	1400	61872MA	372	428	2	12,0
1100	1400	61972MA	373	467	2,5	28,0
1000	1300	16072MA	375	525	3	49,0
1000	1300	6072MA	378	522	4	64,5
1000	1300	61876MA	392	468	2	20,0
1000	1300	61976MA	395	505	3	40,0
950	1200	16076MA	395	545	3	51,0
950	1200	6076M	398	542	4	67,5
1000	1300	61880MA**	412	488	2	20,5
950	1200	61980MA**	415	525	3	41,5
900	1100	6080M**	418	582	4	87,5
950	1200	61884MA**	432	508	2	21,5
900	1100	61984MA**	435	545	3	43,0
900	1100	6084M**	438	602	4	91,5
900	1100	61888MA**	452	528	2	22,5
900	1100	61988MA**	455	585	3	60,5
850	1000	6088M**	463	627	5	105
900	1100	61892MA**	473	567	2,5	35,0
850	1000	61992MA**	476	604	3	62,5
800	950	6092MB**	483	657	5	120
850	1000	61896MA**	493	587	2,5	36,5
800	950	61996MA**	498	632	4	74,0
750	900	6096MB**	503	677	5	125
800	950	618/500MA**	513	607	2,5	40,5
750	900	619/500MA**	518	652	4	77,0
750	900	60/500MA**	523	697	5	135

Single row ball bearings

d = 530 to 1060 mm

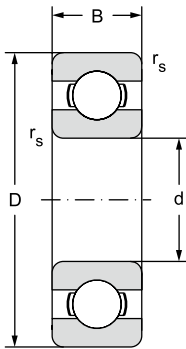

12.1.1

Main dimensions				Basic load rating		Fatigue load limit
d	D	B	r _s	Dynamic C _r	Static C _{0r}	P _u
mm				kN		kN
530	650	56	3	332	655	11,2
	710	82	5	488	930	15,6
	780	112	6	650	1270	20,8
560	680	56	3	345	695	11,8
	750	85	5	494	980	16,3
	820	115	6	663	1470	22
600	730	60	3	364	765	12,5
	800	90	5	585	1220	19,6
630	780	69	4	442	965	15,3
	850	100	6	624	1340	21,2
	920	128	7,5	819	1760	27
670	820	69	4	442	1000	15,6
	900	103	6	676	1500	22,4
	980	136	7,5	904	2040	30
710	870	74	4	475	1100	16,6
	950	106	6	663	1500	22
	1030	140	7,5	956	2200	31,5
750	920	78	5	527	1250	18,3
	1000	112	6	761	1800	25,5
800	980	82	5	559	1370	19,3
	1060	115	6	832	2040	28,5
	1150	155	7,5	1010	2550	34,5
850	1030	82	5	559	1430	19,6
900	1090	85	5	619	1530	22,047
1000	1220	100	6	637	1800	22,8
1060	1280	100	6	728	2120	26,5

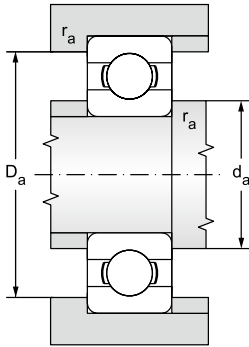

** Bearings in the new standard NEW FORCE

Limiting speed for lubrication with		Bearing designation	Abutment and Fillet Dimensions			Weight ~ kg
Grease	Oil		d_a min	D_a max	r_a max	
min^{-1}			mm			
750	900	618/530MA**	543	637	2,5	39,5
700	850	619/530MA**	548	692	4	90,5
670	800	60/530MA**	553	757	5	185
700	850	618/560MA**	573	667	2,5	42,0
670	800	619/560MA**	578	732	4	105
630	750	60/560MA**	583	797	5	210
670	800	618/600MA**	613	717	2,5	52,0
630	750	619/600MA**	618	782	4	125
630	750	618/630MA**	645	765	3	73,0
600	700	619/630MA**	653	827	5	160
560	670	60/630MB**	658	892	6	285
560	670	618/670MA**	685	805	3	83,5
530	630	619/670MA**	693	877	5	185
500	600	60/670MA**	698	952	6	345
530	630	618/710MA**	725	855	3	93,5
500	600	619/710MA**	733	927	5	220
480	560	60/710MA**	738	1002	6	375
500	600	618/750MA**	768	902	4	110
480	560	619/750MA**	773	977	5	255
450	530	618/800MA**	818	962	4	130
420	500	619/800MA**	823	1037	5	275
400	500	60/800MA**	828	1122	6	535
430	500	618/850MA**	868	1012	4	140
380	450	618/900MA**	920	1070	4	165
340	400	618/1000MA**	1023	1197	5	245
300	360	618/1060MA**	1083	1257	5	260

Single Row Ball Bearings with Seals or Shields $d = 3$ to 160 mm

$d = 3$ to 10 mm

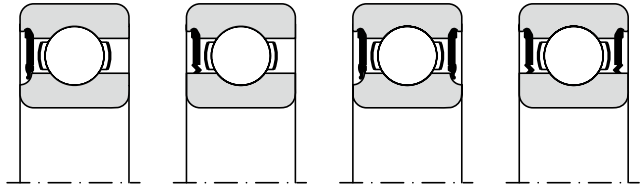
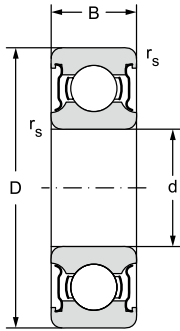

RS

RSR

ZRS

ZRSR

12.1.2

Main dimensions				Basic load rating		Fatigue load limit	Bearing designation	
d	D	B	r_s	Dynamic	Static	P_u	Z, ZR	2Z, 2ZR
			min	C_r	C_{or}			
mm				kN		kN	RS, RSR	2RS, 2RSR
3	10	4	0,15	0,645	0,229	0,01	623-ZR	623-2ZR
4	13	5	0,2	1,17	0,412	0,02	624-ZR	624-2ZR
	16	5	0,3	1,88	0,677	0,03	634-ZR	634-2ZR
5	16	5	0,3	1,88	0,677	0,03	625-ZR	625-2ZR
	19	6	0,3	2,84	1,08	0,05	635-ZR	635-2ZR
6	19	6	0,3	2,84	1,08	0,05	626-ZR	626-2ZR
	7	19	6	0,3	2,84	1,08	0,05	607-RSR
19		6	0,3	2,84	1,08	0,05	607-ZR	607-2ZR
22		7	0,3	3,28	1,36	0,06	627-ZR	627-2ZR
8	22	7	0,3	3,28	1,36	0,06	608-ZR	608-2ZR
	22	7	0,3	3,28	1,36	0,06	608-RSR	608-2RSR
9	24	7	0,3	3,67	1,64	0,07	609-ZR	609-2ZR
	24	7	0,3	3,67	1,64	0,07	609-RSR	609-2RSR
	26	8	0,3	4,56	1,96	0,09	629-ZR	629-2ZR
	26	8	0,3	4,56	1,96	0,09	629-RSR	629-2RSR
10	19	5	0,3	1,38	0,59	0,025	-	61800-2Z
	19	5	0,3	1,38	0,59	0,025	-	61800-2RSR
	22	6	0,3	2,08	0,85	0,036	-	61900-2Z
	22	6	0,3	2,08	0,85	0,036	-	61900-2RSR
	26	8	0,3	4,56	1,96	0,09	6000-ZR	6000-2ZR
	26	8	0,3	4,56	1,96	0,09	6000-RSR	6000-2RSR
	26	12	0,3	4,62	1,96	0,083	-	63000-2RSR
	30	9	0,6	6,05	2,51	0,11	6200-ZR	6200-2ZR
	30	9	0,6	6,05	2,51	0,11	6200-RSR	6200-2RSR
	30	14	0,6	6,05	2,51	0,11	62200-ZR	62200-2ZR
	30	14	0,6	6,05	2,51	0,11	62200-RSR	62200-2RSR
	35	11	0,6	8,07	3,43	0,16	6300-ZR	6300-2ZR
35	11	0,6	8,07	3,43	0,16	6300-RS	6300-2RS	
35	17	0,6	8,06	3,4	0,143	-	62300-2RSR	

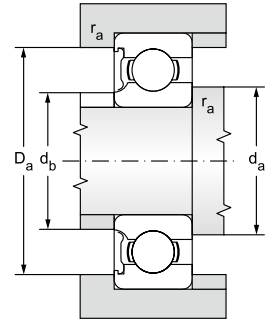
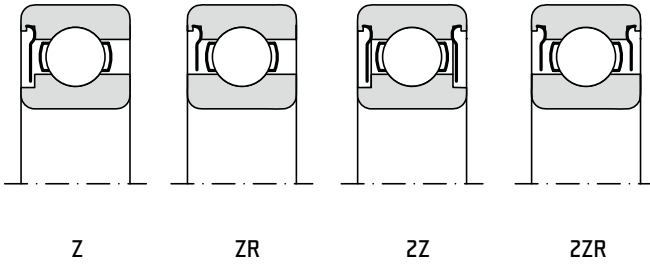

Limiting speed for lubrication with			Abutment and Fillet Dimensions					Weight
Grease		Oil	d	d _a	d _b	D _a	r _a	~
Z, 2Z	RS, 2RS	Z	min	max	max	max		
min ⁻¹			mm					kg
40000	-	50000	3	4,2	4,8	8,5	0,1	0,002
38000	-	45000	4	5,5	5,8	11,2	0,2	0,004
35000	-	42000		6,2	6,5	13,4	0,3	0,005
35000	-	42000	5	7	7	14	0,3	0,006
35000	-	42000		7,2	7,5	15,8	0,3	0,009
35000	-	42000	6	8,2	8,3	17	0,3	0,01
-	24000	42000	7	9	9	17	0,3	0,01
35000	-	42000		9	9	17	0,3	0,01
35000	-	42000		9,2	9,8	19,5	0,3	0,012
35000	-	42000	8	10	10	20	0,3	0,015
-	24000	-		10	10	20	0,3	0,015
35000	-	42000	9	11	12	22	0,3	0,018
-	24000	-		11	12	22	0,3	0,018
35000	-	42000		12	12,5	22,5	0,3	0,02
-	24000	-		12	12,5	22,5	0,3	0,02
36000	-	43000	10	12	12	17	0,3	0,006
-	20000	-		11,8	11,8	17	0,3	0,006
34000	-	40000		12	12	20	0,3	0,01
-	19000	-		12	12	20	0,3	0,01
28000	-	33000		12	12,5	24	0,3	0,02
-	19000	-		12	12,5	24	0,3	0,02
-	19000	-		12	12	24	0,3	0,025
25000	-	30000		14	14,4	26	0,6	0,032
-	17000	-		14	14,4	26	0,6	0,032
25000	-	30000		14	14,4	26	0,6	0,04
-	17000	-		14	14,4	26	0,6	0,04
22000	-	27000		14	15	31	0,6	0,053
-	15000	-		14	15	31	0,6	0,053
-	15000	-		14,2	14,2	30,8	0,6	0,06

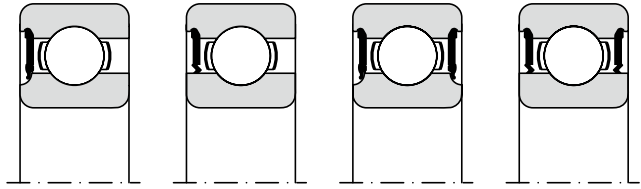
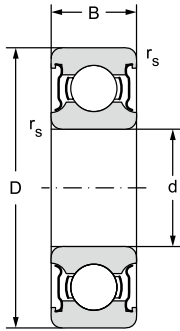

RS

RSR

ZRS

ZRSR

12.1.2	Main dimensions				Basic load rating		Fatigue load limit	Bearing designation	
	d	D	B	r _s	Dynamic	Static	P _u	Z, ZR	2Z, 2ZR
	mm				C _r	C _{or}			
	12	21	5	0,3	1,43	0,67	0,028	-	61801-2Z
		21	5	0,3	1,43	0,67	0,028	-	61801-2RSR
		24	6	0,3	2,25	0,98	0,043	-	61901-2Z
		24	6	0,3	2,25	0,98	0,043	-	61901-2RSR
		28	8	0,3	5,09	2,36	0,11	6001-ZR	6001-2ZR
		28	8	0,3	5,09	2,36	0,11	6001-RSR	6001-2RSR
		28	12	0,3	5,07	2,36	0,1	-	63001-2RSR
		30	8	0,3	5,07	2,36	0,1	-	16101-2RSR
		32	10	0,6	6,91	3,1	0,14	6201-ZR	6201-2ZR
		32	10	0,6	6,91	3,1	0,14	6201-RSR	6201-2RSR
		32	14	0,6	6,91	3,1	0,14	62201-ZR	62201-2ZR
		32	14	0,6	6,91	3,1	0,14	62201-RS	62201-2RS
		37	12	1	9,76	4,24	0,19	6301-ZR	6301-2ZR
		37	12	1	9,76	4,24	0,19	6301-RS	6301-2RS
		37	17	1	9,75	4,15	0,176	-	62301-2RSR
	15	24	5	0,3	1,56	0,8	0,034	-	61802-2Z
		24	5	0,3	1,56	0,8	0,034	-	61802-2RSR
		28	7	0,3	4,36	2,24	0,095	-	61902-2Z
		28	7	0,3	4,36	2,24	0,095	-	61902-2ZR
		28	7	0,3	4,36	2,24	0,095	-	61902-2RSR
		32	9	0,3	5,59	2,86	0,13	6002-ZR	6002-2ZR
		32	9	0,3	5,59	2,86	0,13	6002-RS	6002-2RS
		32	13	0,3	5,59	2,85	0,12	--	63002-2RSR
		35	11	0,6	7,72	3,75	0,17	6202-Z	6202-2Z
		35	11	0,6	7,72	3,75	0,17	6202-RS	6202-2RS
		35	14	0,6	7,72	3,75	0,17	62202-ZR	62202-2ZR
		35	14	0,6	7,72	3,75	0,17	62202-RS	62202-2RS
		42	13	1	11,3	5,34	0,24	6302-ZR	6302-2ZR
		42	13	1	11,3	5,34	0,24	6302-RS	6302-2RS
		42	17	1	11,4	5,4	0,228	-	62302-2RSR

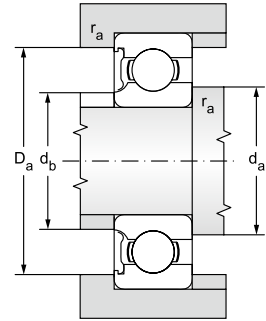
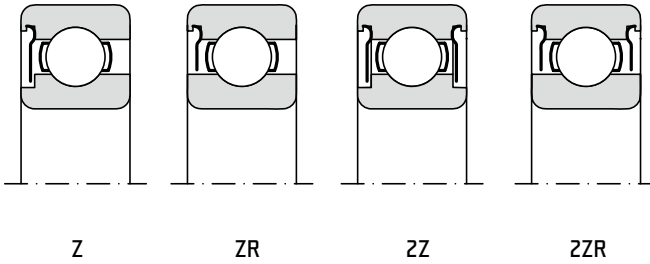

Limiting speed for lubrication with			Abutment and Fillet Dimensions					Weight
Grease		Oil	d	d _a	d _b	D _a	r _a	~
Z, 2Z	RS, 2RS	Z	min	max	max	max		
min ⁻¹			mm					kg
32000	-	38000	12	14	14	19	0,3	0,006
-	19000	-		14	14	19	0,3	0,006
30000	-	36000		14	14	22	0,3	0,011
-	18000	-		14	14	22	0,3	0,011
25000	-	30000		14	14,5	26	0,3	0,022
-	17000	-		14	14,5	26	0,3	0,022
-	17000	-		14	14	26	0,3	0,029
-	16000	-		14,4	14,4	27,6	0,3	0,023
22000	-	27000		16	16,5	28	0,6	0,037
-	15000	-		16	16,5	28	0,6	0,037
22000	-	27000		16	16,5	28	0,6	0,045
-	15000	-		16	16,5	28	0,6	0,045
20000	-	24000		17	17	32	1	0,06
-	13000	-		17	17	32	1	0,06
-	14000	-		17,6	17,6	31,4	1	0,07
28000	-	34000	15	17	17	22	0,3	0,007
-	17000	-		17	17	22	0,3	0,007
24000	-	30000		17	17	26	0,3	0,016
24000	-	30000		17	17	26	0,3	0,016
-	16000	-		17	17	26	0,3	0,016
21000	-	25000		17	18	30	0,3	0,031
-	14000	-		17	18	30	0,3	0,031
-	14000	-		17	17	30	0,3	0,039
20000	-	24000		19	19,5	31	0,6	0,045
-	13000	-		19	19,5	31	0,6	0,045
20000	-	24000		19	19,5	31	0,6	0,054
-	13000	-		19	19,5	31	0,6	0,054
18000	-	21000		20	20,5	36	1	0,082
-	12000	-		20	20,5	36	1	0,082
-	12000	-		20,6	20,6	36,4	1	0,11

Single Row Ball Bearings with Seals or Shields

d = 17 to 22 mm

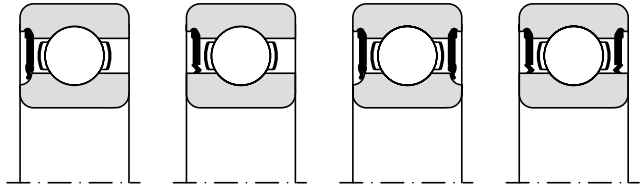
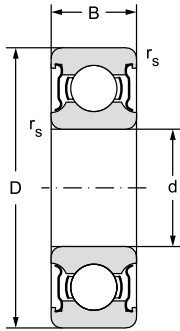

RS

RSR

ZRS

ZRSR

12.1.2

Main dimensions				Basic load rating		Fatigue load limit	Bearing designation	
d	D	B	r _s	Dynamic C _r	Static C _{or}	P _u	Z, ZR	2Z, 2ZR
mm				kN		kN	RS, RSR	2RS, 2RSR
17	26	5	0,3	1,68	0,93	0,039	-	61803-2Z
	26	5	0,3	1,68	0,93	0,039	-	61803-2ZR
	26	5	0,3	1,68	0,93	0,039	-	61803-2RSR
	30	7	0,3	4,62	2,55	0,108	-	61903-2Z
	30	7	0,3	4,62	2,55	0,108	-	61903-2ZR
	30	7	0,3	4,62	2,55	0,108	-	61903-2RSR
	35	10	0,3	6	3,27	0,15	6003-ZR	6003-2ZR
	35	10	0,3	6	3,27	0,15	6003-RS	6003-2RS
	35	14	0,3	6,05	3,25	0,137	-	63003-2RSR
	40	12	0,6	9,53	4,73	0,22	6203-Z	6203-2Z
	40	12	0,6	9,53	4,73	0,22	6203-RS	6203-2RS
	40	16	0,6	9,53	4,73	0,22	62203-Z	62203-2Z
40	16	0,6	9,53	4,73	0,22	62203-RS	62203-2RS	
47	14	1	13,6	6,56	0,3	6303-ZR	6303-2ZR	
47	14	1	13,6	6,56	0,3	6303-RS	6303-2RS	
47	19	1	13,5	6,55	0,275	-	62303-2RSR	
20	32	7	0,3	4,03	2,32	0,104	-	61804-2ZR
	32	7	0,3	4,03	2,32	0,104	-	61804-2RSR
	37	9	0,3	6,37	3,65	0,156	-	61904-2ZR
	37	9	0,3	6,37	3,65	0,156	-	61904-2RSR
	42	12	0,6	9,37	4,97	0,23	6004-ZR	6004-2ZR
	42	12	0,6	9,37	4,97	0,23	6004-RS	6004-2RS
	42	16	0,6	9,36	5	0,212	-	63004-2RSR
	47	14	1	12,8	6,55	0,3	6204-Z	6204-2Z
	47	14	1	12,8	6,55	0,3	6204-RS	6204-2RS
	47	18	1	12,8	6,55	0,3	62204-Z	62204-2Z
	47	18	1	12,8	6,55	0,3	62204-RS	62204-2RS
	47	20,6	1	12,8	6,55	0,3	63204-Z	63204-2Z
47	20,6	1	12,8	6,55	0,3	63204-RS	63204-2RS	
52	15	1,1	15,9	7,81	0,36	6304-Z	6304-2Z	
52	15	1,1	15,9	7,81	0,36	6304-RS	6304-2RS	
52	21	1,1	15,9	7,81	0,36	62304-Z	62304-2Z	
52	21	1,1	15,9	7,81	0,36	62304-RS	62304-2RS	
22	50	14	1	14	7,65	0,325	-	62/22-2RSR

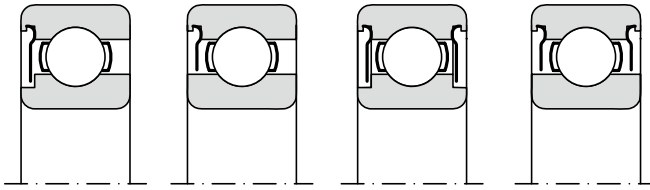

Z

ZR

ZZ

ZZR

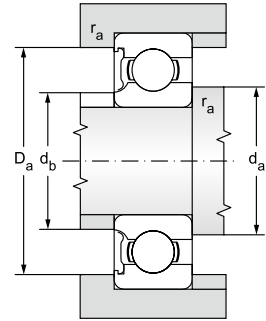

Limiting speed for lubrication with			Abutment and Fillet Dimensions					Weight
Grease		Oil	d	d _a	d _b	D _a	r _a	~
Z, ZZ	RS, 2RS	Z	min	max	max	max		
min ⁻¹			mm					kg
24000	-	30000	17	19	19	24	0,3	0,008
24000	-	30000		19	19	24	0,3	0,008
-	16000	-		19	19	24	0,3	0,008
22000	-	28000		19	19	28	0,3	0,018
22000	-	28000		19	19	28	0,3	0,018
-	14000	-		19	19	28	0,3	0,018
20000	-	24000		19	20	33	0,3	0,04
-	13000	-		19	20	33	0,3	0,04
-	13000	-		19	19	33	0,3	0,052
18000	-	21000		21	21,4	36	0,6	0,065
-	12000	-		21	21,4	36	0,6	0,065
18000	-	21000		21	21,4	36	0,6	0,083
-	12000	-		21	21,4	36	0,6	0,083
16000	-	19000		23	23	41	1	0,12
-	10600	-		23	23	41	1	0,12
-	11000	-		22,6	22,6	41,4	1	0,15
19000	-	24000	20	22	22	30	0,3	0,018
-	13000	-		22	22	30	0,3	0,018
18000	-	22000		22	22	35	0,3	0,038
-	12000	-		22	22	35	0,3	0,038
17000	-	20000		24	24,5	38	0,3	0,07
-	11000	-		24	24,5	38	0,3	0,07
-	11000	-		23,2	23,2	38,8	0,6	0,086
15000	-	18000		25	25,5	42	0,6	0,11
-	10000	-		25	25,5	42	0,6	0,11
15000	-	18000		25	25,5	42	0,6	0,13
-	10000	-		25	25,5	42	0,6	0,13
15000	-	18000		25	25,5	42	0,6	0,15
-	10000	-		25	25,5	42	0,6	0,15
14000	-	17000		26	26,6	45	1	0,14
-	9400	-		26	26,6	45	1	0,14
14000	-	17000		26	26,6	45	1	0,2
-	9400	-		26	26,6	45	1	0,2
-	9500	-	22	27,6	27,6	44,4	1	0,12

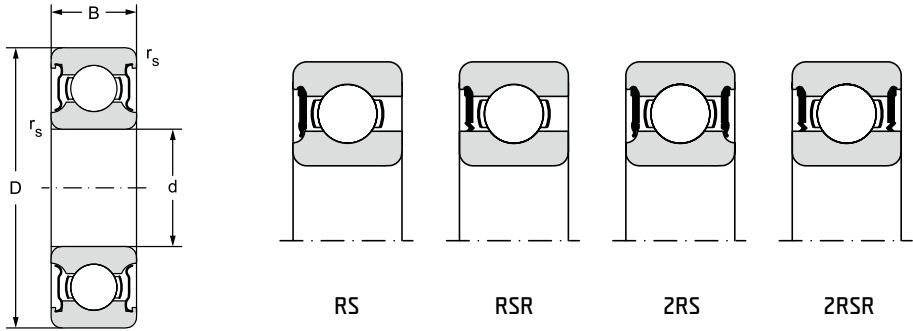

12.1.2

Main dimensions				Basic load rating		Fatigue load limit	Bearing designation		
d	D	B	r _s	Dynamic C _r	Static C _{0r}	P _u	Z, ZR	2Z, 2ZR	
mm				kN		kN	RS, RSR	2RS, 2RSR	
25	37	7	0,3	4,36	2,6	0,125	-	61805-2ZR	
	37	7	0,3	4,36	2,6	0,125	-	61805-2RSR	
	42	9	0,3	7,02	4,3	0,193	-	61905-2ZR	
	42	9	0,3	7,02	4,3	0,193	-	61905-2RSR	
	47	12	0,6	10,1	5,81	0,26	6005-ZR	6005-2ZR	
	47	12	0,6	10,1	5,81	0,26	6005-RS	6005-2RS	
	47	16	0,6	11,2	6,55	0,275	-	63005-2RSR	
	52	15	1	14	7,94	0,36	6205-Z	6205-2Z	
	52	15	1	14	7,94	0,36	6205-RS	6205-2RS	
	52	18	1	14	7,94	0,36	62205-Z	62205-2Z	
	52	18	1	14	7,94	0,36	62205-RS	62205-2RS	
	30	62	17	1,1	21,1	10,8	0,49	6305-Z	6305-2Z
62		17	1,1	21,1	10,8	0,49	6305-RS	6305-2RS	
62		24	1,1	21,1	10,8	0,49	62305-Z	62305-2Z	
62		24	1,1	21,1	10,8	0,49	62305-RS	62305-2RS	
30		42	7	0,3	4,49	2,9	0,146	-	61806-2ZR
		42	7	0,3	4,49	2,9	0,146	-	61806-2RSR
		47	9	0,3	7,28	4,55	0,212	-	61906-2ZR
		47	9	0,3	7,28	4,55	0,212	-	61906-2RSR
		55	13	1	13,2	8,25	0,38	6006-Z	6006-2Z
		55	13	1	13,2	8,25	0,38	6006-RS	6006-2RS
		55	19	1	13,3	8,3	0,355	-	63006-2RSR
		62	16	1	19,4	11,2	0,51	6206-Z	6206-2Z
	62	16	1	19,4	11,2	0,51	6206-RS	6206-2RS	
	62	20	1	19,4	11,2	0,51	62206-Z	62206-2Z	
	62	20	1	19,4	11,2	0,51	62206-RS	62206-2RS	
	72	19	1,1	29,7	15,7	0,71	6306-Z	6306-2Z	
72	19	1,1	29,7	15,7	0,71	6306-RS	6306-2RS		
72	27	1,1	28,1	16	0,67	-	62306-2RSR		

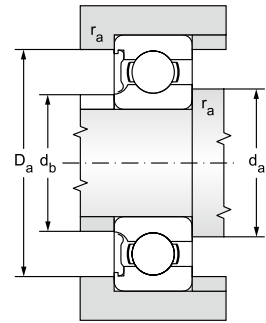
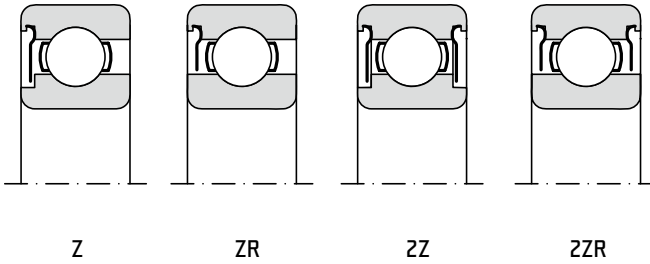

Limiting speed for lubrication with			Abutment and Fillet Dimensions					Weight
Grease		Oil	d	d _a	d _b	D _a	r _a	~
Z, 2Z	RS, 2RS	Z	min	max	max	max		
min ⁻¹			mm					kg
17000	-	20000	25	27	27	35	0,3	0,022
-	11000	-		27	27	35	0,3	0,022
16000	-	19000		27	27	40	0,3	0,045
-	10000	-		27	27	40	0,3	0,045
14000	-	17000		28	29	43	0,6	0,081
-	9400	-		28	29	43	0,6	0,081
-	9500	-		29,2	29,2	43,8	0,6	0,1
12600	-	15000		30	30,5	47	1	0,13
-	8400	-		30	30,5	47	1	0,13
12600	-	15000		30	30,5	47	1	0,15
-	8400	-		30	30,5	47	1	0,15
11000	-	13000		31	33	55	1	0,23
-	7500	-		31	33	55	1	0,23
11000	-	13000		31	33	55	1	0,32
-	7500	-		31	33	55	1	0,32
15000	-	18000	30	32	32	40	0,3	0,027
-	9500	-		32	32	40	0,3	0,027
14000	-	17000		32	32	45	0,3	0,051
-	8500	-		32	32	45	0,3	0,051
12000	-	14000		34	35	50	1	0,12
-	7900	-		34	35	50	1	0,12
-	8000	-		34,6	34,6	50,4	1	0,16
11000	-	13000		35	36,7	57	1	0,2
-	7500	-		35	36,7	57	1	0,2
11000	-	13000		35	36,7	57	1	0,24
-	7500	-		35	36,7	57	1	0,24
10000	-	12000		36	38,9	65	1	0,35
-	6700	-		36	38,9	65	1	0,35
-	6300	-		37	37	65	1	0,48

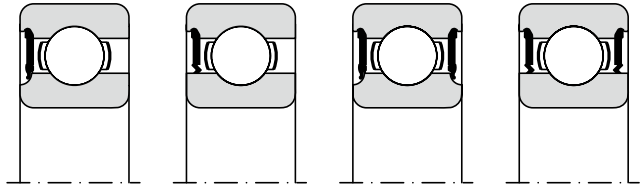
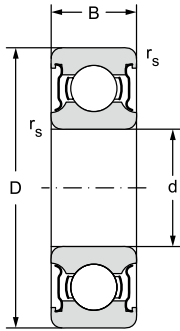

RS

RSR

ZRS

ZRSR

12.1.2

Main dimensions				Basic load rating		Fatigue load limit	Bearing designation	
d	D	B	r _s	Dynamic C _r	Static C _{0r}	P _u	Z, ZR	2Z, 2ZR
mm				kN		kN	RS, RSR	2RS, 2RSR
35	47	7	0,3	4,75	3,2	0,166	-	61807-2ZR
	47	7	0,3	4,75	3,2	0,166	-	61807-2RSR
	55	10	0,6	9,56	6,8	0,29	-	61907-2ZR
	55	10	0,6	9,56	6,8	0,29	-	61907-2RSR
	62	14	1	16	10,3	0,47	6007-Z	6007-2Z
	62	14	1	16	10,3	0,47	6007-RS	6007-2RS
	62	20	1	15,9	10,2	0,44	-	63007-2RSR
	72	17	1,1	25,7	15,2	0,69	6207-Z	6207-2Z
	72	17	1,1	25,7	15,2	0,69	6207-RS	6207-2RS
	72	23	1,1	25,5	15,3	0,655	-	62207-2RSR
	80	21	1,5	33,4	19,2	0,87	6307-Z	6307-2Z
	80	21	1,5	33,4	19,2	0,87	6307-RS	6307-2RS
80	31	1,5	33,2	19	0,815	-	62307-2RSR	
40	52	7	0,3	4,94	3,45	0,186	-	61808-2ZR
	52	7	0,3	4,94	3,45	0,186	-	61808-2RSR
	62	12	0,6	13,8	10	0,425	-	61908-2ZR
	62	12	0,6	13,8	10	0,425	-	61908-2RSR
	68	15	1	16,8	11,5	0,52	6008-Z	6008-2Z
	68	15	1	16,8	11,5	0,52	6008-RS	6008-2RS
	68	21	1	16,8	11,6	0,49	-	63008-2RSR
	80	18	1,1	32,6	19,9	0,9	6208-Z	6208-2Z
	80	18	1,1	32,6	19,9	0,9	6208-RS	6208-2RS
	80	23	1,1	30,7	19	0,8	-	62208-2RSR
	90	23	1,5	40,8	24	1,09	6308-Z	6308-2Z
	90	23	1,5	40,8	24	1,09	6308-RS	6308-2RS
90	33	1,5	41	24	1,02	-	62308-2RSR	
45	58	7	0,3	6,63	6,1	0,26	-	61809-2ZR
	58	7	0,3	6,63	6,1	0,26	-	61809-2RSR
	68	12	0,6	14	10,8	0,465	-	61909-2ZR
	68	12	0,6	14	10,8	0,465	-	61909-2RSR
	75	16	1	21,1	15,3	0,7	6009-Z	6009-2Z
	75	16	1	21,1	15,3	0,7	6009-RS	6009-2RS
	75	23	1	20,8	14,6	0,64	-	63009-2RSR
	85	19	1,1	32,7	20,3	0,92	6209-Z	6209-2Z
	85	19	1,1	32,7	20,3	0,92	6209-RS	6209-2RS
	85	23	1,1	33,2	21,6	0,915	-	62209-2RSR
	100	25	1,5	52,8	31,7	1,44	6309-Z	6309-2Z
	100	25	1,5	52,8	31,7	1,44	6309-RS	6309-2RS
100	36	1,5	52,7	31,5	1,34	-	62309-2RSR	

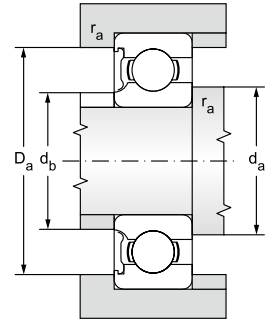
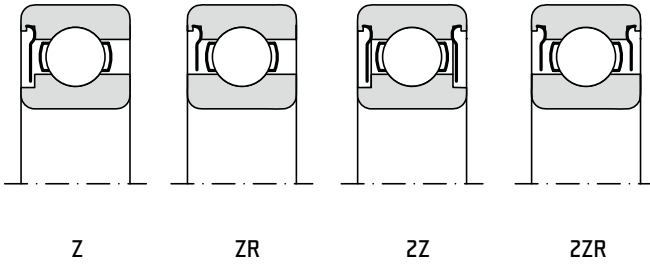

Limiting speed for lubrication with			Abutment and Fillet Dimensions					Weight
Grease		Oil	d	d _a	d _b	D _a	r _a	~
Z, 2Z	RS, 2RS	Z	min	max	max	max		
min ⁻¹			mm					kg
13000	-	16000	35	37	37	45	0,3	0,03
-	8000	-		37	37	45	0,3	0,03
11000	-	14000		38,2	38,2	51,8	0,6	0,08
-	7500	-		38,2	38,2	51,8	0,6	0,08
10600	-	12600		39,5	39,5	57	1	0,16
-	7100	-		39,5	39,5	57	1	0,16
-	7000	-		39,6	39,6	57,4	1	0,21
9400	-	11000		42	42	65	1	0,29
-	6300	-		42	42	65	1	0,29
-	6300	-		42	42	65	1	0,37
8400	-	10000		42	44	71	1,5	0,46
-	5600	-		42	44	71	1,5	0,46
-	6000	-		44	44	71	1,5	0,66
11000	-	14000	40	42	42	50	0,3	0,034
-	7500	-		42	42	50	0,3	0,034
10000	-	13000		43,2	43,2	58,8	0,6	0,12
-	6700	-		43,2	43,2	58,8	0,6	0,12
9400	-	11000		44	46	63	1	0,2
-	6300	-		44	46	63	1	0,2
-	6300	-		44,6	44,6	63,4	1	0,26
8400	-	10000		47	48	73	1	0,37
-	5600	-		47	48	73	1	0,37
-	5600	-		47	47	73	1	0,44
7900	-	9400		47	50,6	81	1,5	0,64
-	5300	-		47	50,6	81	1,5	0,64
-	5000	-		49	49	81	1,5	0,89
9500	-	12000	45	47	47	56	0,3	0,04
-	6700	-		47	47	56	0,3	0,04
9000	-	11000		48,2	48,2	64,8	0,6	0,14
-	6000	-		48,2	48,2	64,8	0,6	0,14
8400	-	10000		49	51,5	70	1	0,25
-	5600	-		49	51,5	70	1	0,25
-	5600	-		50,8	50,8	69,2	1	0,34
7900	-	9400		52	52,5	78	1	0,41
-	5300	-		52	52,5	78	1	0,41
-	5000	-		52	52	78	1	0,48
7100	-	8400		52	56	91	1,5	0,83
-	4700	-		52	56	91	1,5	0,83
-	4500	-		54	54	91	1,5	1,15

Single Row Ball Bearings with Seals or Shields

d = 50 to 60 mm

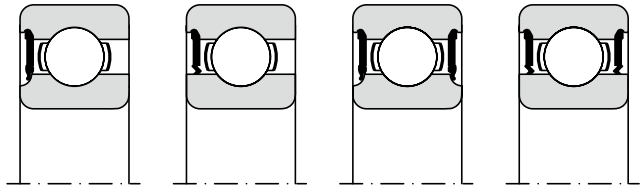
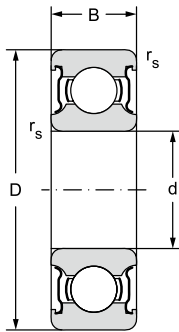

RS

RSR

ZRS

ZRSR

12.1.2

Main dimensions				Basic load rating		Fatigue load limit	Bearing designation	
d	D	B	r _s	Dynamic C _r	Static C _{or}	P _u	Z, ZR	2Z, 2ZR
mm				kN		kN	RS, RSR	2RS, 2RSR
50	65	7	0,3	6,76	6,8	0,285	-	61810-2ZR
	65	7	0,3	6,76	6,8	0,285	-	61810-2RSR
	72	12	0,6	14,6	11,8	0,5	-	61910-2ZR
	72	12	0,6	14,6	11,8	0,5	-	61910-2RSR
	80	16	1	21,7	16,7	0,76	6010-Z	6010-2Z
	80	16	1	21,7	16,7	0,76	6010-RS	6010-2RS
	80	23	1	21,6	16	0,71	-	63010-2RSR
	90	20	1,1	35,1	23,3	1,06	6210-Z	6210-2Z
	90	20	1,1	35,1	23,3	1,06	6210-RS	6210-2RS
	90	23	1,1	35,1	23,2	0,98	-	62210-2RSR
	110	27	2	61,8	37,7	1,72	6310-Z	6310-2Z
110	27	2	61,8	37,7	1,72	6310-RS	6310-2RS	
110	40	2	61,8	38	1,6	-	62310-2RSR	
55	72	9	0,3	9,04	8,8	0,375	-	61811-2ZR
	72	9	0,3	9,04	8,8	0,375	-	61811-2RSR
	80	13	1	16,5	14	0,6	-	61911-2ZR
	80	13	1	16,5	14	0,6	-	61911-2RSR
	90	18	1,1	28,2	21,3	0,97	6011-Z	6011-2Z
	90	18	1,1	28,2	21,3	0,97	6011-RS	6011-2RS
	100	21	1,5	43,4	29,4	1,34	6211-Z	6211-2Z
	100	21	1,5	43,4	29,4	1,34	6211-RS	6211-2RS
	100	25	1,5	43,6	29	1,25	-	62211-2RSR
	120	29	2	71	44,7	2,03	6311-Z	6311-2Z
	120	29	2	71	44,7	2,03	6311-RS	6311-2RS
120	43	2	71,5	45	1,9	-	62311-2RSR	
60	78	10	0,3	11,9	11,4	0,49	-	61812-2ZR
	78	10	0,3	11,9	11,4	0,49	-	61812-2RSR
	85	13	1	16,5	14,3	0,6	-	61912-2ZR
	85	13	1	16,5	14,3	0,6	-	61912-2RSR
	95	18	1,1	29,3	23,3	1,06	6012-Z	6012-2Z
	95	18	1,1	29,3	23,3	1,06	6012-RS	6012-2RS
	110	22	1,5	52,5	35,8	1,63	6212-Z	6212-2Z
	110	22	1,5	52,5	35,8	1,63	6212-RS	6212-2RS
	110	28	1,5	52,7	36	1,53	-	62212-2RSR
	130	31	2,1	81,5	52,1	2,37	6312-Z	6312-2Z
	130	31	2,1	81,5	52,1	2,37	6312-RS	6312-2RS
130	46	2,1	81,9	52	2,2	-	62312-2RSR	

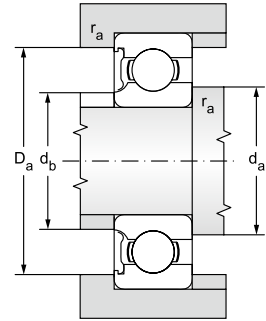
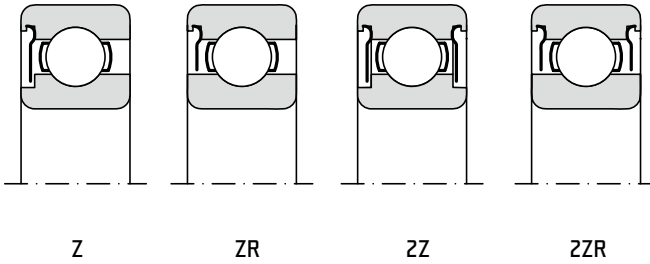

Limiting speed for lubrication with			Abutment and Fillet Dimensions					Weight
Grease		Oil	d	d _a	d _b	D _a	r _a	~
Z, 2Z	RS, 2RS	Z	min	max	max	max		
min ⁻¹			mm					kg
9000	-	11000	50	52	52	63	0,3	0,052
-	6000	-		52	52	63	0,3	0,052
8500	-	10000		53,2	53,2	68,8	0,6	0,14
-	5600	-		53,2	53,2	68,8	0,6	0,14
7900	-	9400		54	56,5	75	1	0,26
-	5300	-		54	56,5	75	1	0,26
-	5000	-		54,6	54,6	75,4	1	0,37
7100	-	8400		57	58	83	1	0,46
-	4700	-		57	58	83	1	0,46
-	4800	-		57	57	83	1	0,52
6300	-	7500		60	61,8	100	2	1,08
-	4200	-		60	61,8	100	2	1,08
-	4300	-		61	61	99	2	1,55
8500	-	10000	55	57	57	70	0,3	0,083
-	5300	-		57	57	70	0,3	0,083
8000	-	9500		59,6	59,6	75,4	1	0,19
-	5000	-		59,6	59,6	75,4	1	0,19
7100	-	8400		60	62,5	84	1	0,39
-	4700	-		60	62,5	84	1	0,39
6700	-	7900		62	65	91	1,5	0,61
-	4500	-		62	65	91	1,5	0,61
-	4300	-		64	64	91	1,5	0,7
5600	-	6700		65	67	110	2	1,38
-	3800	-		65	67	110	2	1,38
-	3800	-		66	66	109	2	1,95
7500	-	9000	60	62	62	76	0,3	0,11
-	4800	-		62	62	76	0,3	0,11
7500	-	9000		64,6	64,6	80,4	1	0,2
-	4500	-		64,6	64,6	80,4	1	0,2
6700	-	7900		65	68	88	1	0,42
-	4500	-		65	68	88	1	0,42
6000	-	7100		67	70,2	101	1,5	0,79
-	4000	-		67	70,2	101	1,5	0,79
-	4000	-		69	69	101	1,5	0,97
5300	-	6300		72	75	118	2	1,72
-	3500	-		72	75	118	2	1,72
-	3400	-		72	72	118	2	2,5

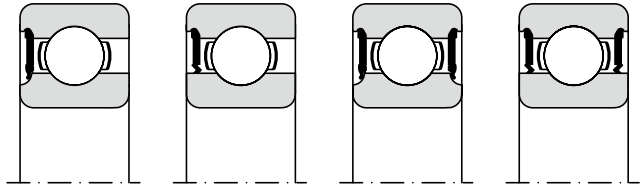
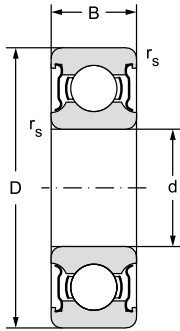

RS

RSR

ZRS

ZRSR

12.1.2

Main dimensions				Basic load rating		Fatigue load limit	Bearing designation	
d	D	B	r _s	Dynamic C _r	Static C _{0r}	P _u	Z, ZR	2Z, 2ZR
mm				kN		kN	RS, RSR	2RS, 2RSR
65	85	10	0,6	12,4	12,7	0,54	-	61813-2ZR
	85	10	0,6	12,4	12,7	0,54	-	61813-2RSR
	90	13	1	17,4	16	0,68	-	61913-2ZR
	90	13	1	17,4	16	0,68	-	61913-2RSR
	100	18	1,1	30,5	25,1	1,14	6013-Z	6013-2Z
	100	18	1,1	30,5	25,1	1,14	6013-RS	6013-2RS
	120	23	1,5	57,2	40	1,82	6213-Z	6213-2Z
	120	23	1,5	57,2	40	1,82	6213-RS	6213-2RS
	120	31	1,5	55,9	40,5	1,73	-	62213-2RSR
	140	33	2,1	92,6	59,6	2,68	6313-Z	6313-2Z
140	33	2,1	92,6	59,6	2,68	6313-RS	6313-2RS	
140	48	2,1	92,3	60	2,5	-	62313-2RSR	
70	90	10	0,6	12,4	13,2	0,56	-	61814-2ZR
	90	10	0,6	12,4	13,2	0,56	-	61814-2RSR
	100	16	1	23,8	21,2	0,9	-	61914-2ZR
	100	16	1	23,8	21,2	0,9	-	61914-2RSR
	110	20	1,1	38	31	1,41	6014-Z	6014-2Z
	110	20	1,1	38	31	1,41	6014-RS	6014-2RS
	125	24	1,5	62	43,8	1,99	6214-Z	6214-2Z
	125	24	1,5	62	43,8	1,99	6214-RS	6214-2RS
	125	31	1,5	60,5	45	1,9	-	62214-2RSR
	150	35	2,1	104	68,1	2,95	6314-Z	6314-2Z
150	35	2,1	104	68,1	2,95	6314-RS	6314-2RS	
150	51	2,1	104	68	2,75	-	62314-2RSR	
75	95	10	0,6	12,7	14,3	0,61	-	61815-2ZR
	95	10	0,6	12,7	14,3	0,61	-	61815-2RSR
	105	16	1	24,2	19,3	0,965	-	61915-2ZR
	105	16	1	24,2	19,3	0,965	-	61915-2RSR
	115	20	1,1	39,7	33,2	1,51	6015-Z	6015-2Z
	115	20	1,1	39,7	33,2	1,51	6015-RS	6015-2RS
	130	25	1,5	66,2	49,3	2,21	6215-Z	6215-2Z
	130	25	1,5	66,2	49,3	2,21	6215-RS	6215-2RS
	160	37	2,1	114	76,4	3,2	6315-Z	6315-2Z
	160	37	2,1	114	76,4	3,2	6315-RS	6315-2RS

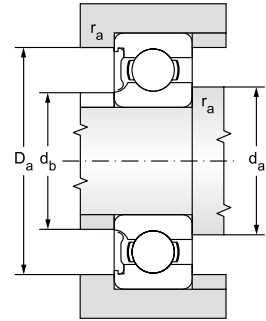
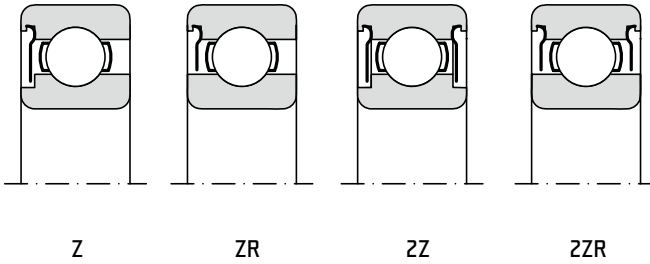

Limiting speed for lubrication with			Abutment and Fillet Dimensions					Weight
Grease		Oil	d	d _a	d _b	D _a	r _a	~
Z, 2Z	RS, 2RS	Z	min	max	max	max		
min ⁻¹			mm					kg
7000	-	8500	65	68,2	68,2	81,8	0,6	0,13
-	4500	-		68,2	68,2	81,8	0,6	0,13
6700	-	8000		69,6	69,6	85,4	1	0,22
-	4300	-		69,6	69,6	85,4	1	0,22
6300	-	7500		70	73	93	1	0,44
-	4200	-		70	73	93	1	0,44
5300	-	6300		72	77	111	1,5	1
-	3500	-		72	77	111	1,5	1
-	3600	-		74	74	111	1,5	1,25
5000	-	6000		76	78	128	2	2,1
-	3300	-		76	78	128	2	2,1
-	3200	-		77	77	128	2	3
6700	-	8000	70	73,2	73,2	86,8	0,6	0,14
-	4300	-		73,2	73,2	86,8	0,6	0,14
6300	-	7500		74,6	74,6	95,4	1	0,35
-	4000	-		74,6	74,6	95,4	1	0,35
5600	-	6700		75	78	103	1	0,62
-	3800	-		75	78	103	1	0,62
5300	-	6300		77	82	116	1,5	1,09
-	3500	-		77	82	116	1,5	1,09
-	3400	-		79	79	116	1,5	1,3
4700	-	5600		81	85	138	2	2,53
-	3200	-		81	85	138	2	2,53
-	3000	-		82	82	138	2	3,55
6300	-	7500	75	78,2	78,2	91,8	0,6	0,15
-	4000	-		78,2	78,2	91,8	0,6	0,15
6000	-	7000		79,6	79,6	100	1	0,37
-	3600	-		79,6	79,6	100	1	0,37
5300	-	6300		80	83	108	1	0,64
-	3500	-		80	83	108	1	0,64
5000	-	6000		82	85	121	1,5	1,19
-	3300	-		82	85	121	1,5	1,19
4200	-	5000		86	93	148	2	3,03
-	2800	-		86	93	148	2	3,03

Single Row Ball Bearings with Seals or Shields

d = 80 to 95 mm

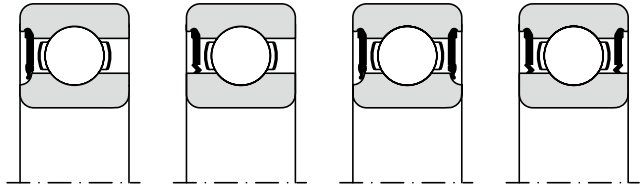
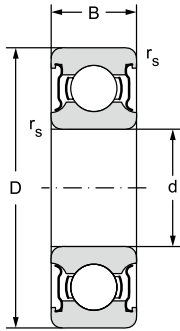

RS

RSR

ZRS

ZRSR

12.1.2

Main dimensions				Basic load rating		Fatigue load limit	Bearing designation	
d	D	B	r _s	Dynamic C _r	Static C _{0r}	P ₀	Z, ZR	2Z, 2ZR
mm				kN		kN	RS, RSR	2RS, 2RSR
80	100	10	0,6	13	15	0,64	-	61816-2ZR
	100	10	0,6	13	15	0,64	-	61816-2RSR
	110	16	1	25,1	20,4	1,02	-	61916-2ZR
	110	16	1	25,1	20,4	1,02	-	61916-2RSR
	125	22	1,1	47,5	39,8	1,79	6016-Z	6016-2Z
	125	22	1,1	47,5	39,8	1,79	6016-RS	6016-2RS
	140	26	2	72,2	53,1	2,3	6216-Z	6216-2Z
	140	26	2	72,2	53,1	2,3	6216-RS	6216-2RS
	170	39	2,1	123	86,2	3,51	6316-Z	6316-2Z
	170	39	2,1	130	86,5	3,25	6316-RSR	6316-2RSR
85	110	13	1	19,5	20,8	0,88	-	61817-2ZR
	110	13	1	19,5	20,8	0,88	-	61817-2RSR
	130	22	1,1	49,8	42,6	1,87	6017-Z	6017-2Z
	130	22	1,1	52	43	1,76	6017-RSR	6017-2RSR
	150	28	2	83,3	63,7	2,67	6217-Z	6217-2Z
	150	28	2	83,3	63,7	2,67	6217-RS	6217-2RS
	180	41	3	133	96,1	3,79	6317-Z	6317-2Z
	180	41	3	140	96,5	3,55	6317-RSR	6317-2RSR
90	115	13	1	19,5	22	0,915	-	61818-2ZR
	115	13	1	19,5	22	0,915	-	61818-2RSR
	140	24	1,5	60,5	50	1,96	6018-Z	6018-2Z
	140	24	1,5	60,5	50	1,96	6018-RSR	6018-2RSR
	160	30	2	96,2	70,8	2,88	6218-Z	6218-2Z
	160	30	2	101	73,5	2,8	6218-RSR	6218-2RSR
	190	43	3	143	104	4	6318-Z	6318-2Z
	190	43	3	151	108	3,8	6318-RSR	6318-2RSR
95	120	13	1	19,9	22,8	0,93	-	61819-2ZR
	120	13	1	19,9	22,8	0,93	-	61819-2RSR
	130	18	1,1	33,8	33,5	1,43	-	61919-2RSR
	145	24	1,5	63,7	54	2,08	6019-Z	6019-2Z
	145	24	1,5	63,7	54	2,08	6019-RSR	6019-2RSR
	170	32	2,1	114	81,5	3	6219-Z	6219-2Z
	170	32	2,1	114	81,5	3	6219-RSR	6219-2RSR
	200	45	3	159	118	4,15	6319-Z	6319-2Z
	200	45	3	159	118	4,15	6319-RSR	6319-2RSR

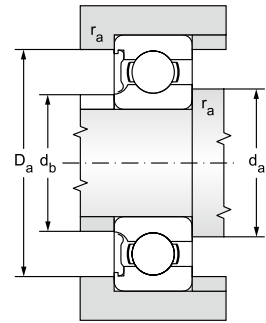
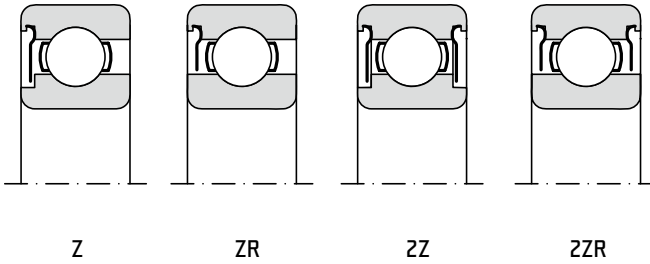

Limiting speed for lubrication with			Abutment and Fillet Dimensions					Weight
Grease		Oil	d	d _a	d _b	D _a	r _a	~
Z, 2Z	RS, 2RS	Z	min	max	max	max		
min ⁻¹			mm					kg
6000	-	7000	80	83,2	83,2	96,8	0,6	0,15
-	3600	-		83,2	83,2	96,8	0,6	0,15
5600	-	6700		84,6	84,6	105	1	0,4
-	3400	-		84,6	84,6	105	1	0,4
5000	-	6000		85	90	118	1	0,86
-	3300	-		85	90	118	1	0,86
4700	-	5600		90	92	130	2	1,41
-	3200	-		90	92	130	2	1,41
4000	-	4700		91	99	158	2	3,62
-	2600	-		92	92	158	2	3,6
5300	-	6300	85	89,6	89,6	105	1	0,27
-	3400	-		89,6	89,6	105	1	0,27
4700	-	5600		90	95	123	1	0,89
-	3000	-		92	92	123	1	0,89
4200	-	5000		95	99	140	2	1,79
-	2800	-		95	99	140	2	1,79
3800	-	4500		98	103	166	2,5	4,26
-	2400	-		99	99	166	2,5	4,25
5300	-	6300	90	94,6	94,6	110	1	0,28
-	3200	-		94,6	94,6	110	1	0,28
4800	-	5600		97	97	133	1,5	1,15
-	2800	-		97	97	133	1,5	1,15
4000	-	4700		100	105	150	2	2,16
-	2600	-		101	101	149	2	2,15
3400	-	4200		103	108	176	2,5	5,15
-	2400	-		104	104	176	2,5	4,9
5000	-	6000	95	99,6	99,6	115	1	0,3
-	3000	-		99,6	99,6	115	1	0,3
-	2800	-		101	101	124	1	0,61
4500	-	5300		102	102	138	1,5	1,2
-	2800	-		102	102	138	1,5	1,2
3600	-	4300		107	107	158	2	2,6
-	3000	-		107	107	158	2	2,6
3200	-	3800		109	109	186	2,5	5,65
-	2800	-		109	109	186	2,5	5,65

Single Row Ball Bearings with Seals or Shields

d = 100 to 130 mm

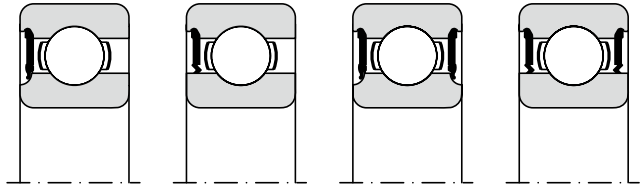
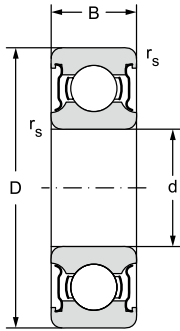

RS

RSR

ZRS

ZRSR

12.1.2

Main dimensions				Basic load rating		Fatigue load limit	Bearing designation	
d	D	B	r _s	Dynamic C _r	Static C _{0r}	P ₀	Z, ZR	2Z, 2ZR
mm				kN		kN	RS, RSR	2RS, 2RSR
100	125	13	1	19,9	24	0,95	-	61820-2ZR
	125	13	1	19,9	24	0,95	-	61820-2RSR
	150	24	1,5	60	54	2,2	6020-Z	6020-2Z
	150	24	1,5	63,7	54	2,04	6020-RSR	6020-2RSR
	180	34	2,1	127	93	3,35	6220-Z	6220-2Z
	180	34	2,1	127	93	3,35	6220-RSR	6220-2RSR
215	47	3	174	140	4,75	6320-Z	6320-2Z	
105	130	13	1	20,8	19,6	1	-	61821-2ZR
	130	13	1	20,8	19,6	1	-	61821-2RSR
	160	26	2	76,1	65,5	2,4	6021-Z	6021-2Z
	160	26	2	76,1	65,5	2,4	6021-RSR	6021-2RSR
	190	36	2,1	140	104	3,65	6221-Z	6221-2Z
	190	36	2,1	140	104	3,65	6221-RSR	6221-2RSR
225	49	3	182	153	5,1	6321-Z	6321-2Z	
110	140	16	1	28,1	26	1,25	-	61822-2ZR
	140	16	1	28,1	26	1,25	-	61822-2RSR
	170	28	2	85,2	73,5	2,4	6022-Z	6022-2Z
	170	28	2	85,2	73,5	2,4	6022-RSR	6022-2RSR
	200	38	2,1	151	118	4	6222-Z	6222-2Z
120	150	16	1	29,1	28	1,29	-	61824-2ZR
	150	16	1	29,1	28	1,29	-	61824-2RSR
	180	28	2	88,4	80	2,75	6024-Z	6024-2Z
	180	28	2	88,4	80	2,75	6024-RSR	6024-2RSR
	215	40	2,1	146	118	3,9	6224-Z	6224-2Z
130	165	18	1,1	37,7	43	1,6	-	61826-2ZR
	165	18	1,1	37,7	43	1,6	-	61826-2RSR
	200	33	2	112	100	3,35	6026-Z	6026-2Z
	200	33	2	112	100	3,35	6026-RSR	6026-2RSR
	230	40	3	156	132	4,15	6226-Z	6226-2Z

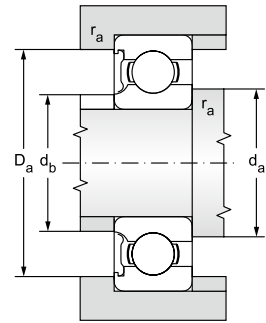
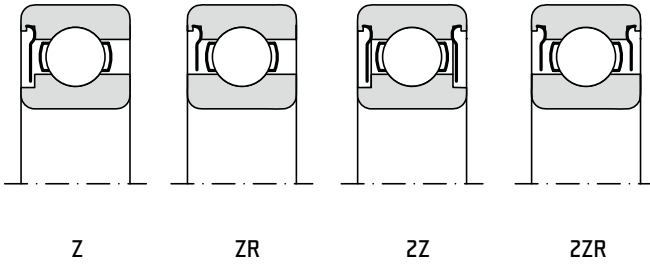

Limiting speed for lubrication with			Abutment and Fillet Dimensions					Weight
Grease		Oil	d	d _a	d _b	D _a	r _a	~
Z, 2Z	RS, 2RS	Z	min	max	max	max		
min ⁻¹			mm					kg
4800	-	5600	100	105	105	120	1	0,31
-	3000	-		105	105	120	1	0,31
4200	-	5000		106	110	142	1,5	1,27
-	2600	-		107	107	143	1,5	1,25
4300	-	5000		112	112	168	2	3,15
-	2400	-		112	112	168	2	3,15
3000	-	3600		114	114	201	2,5	7
4500	-	5300	105	110	110	125	1	0,32
-	2800	-		110	110	125	1	0,32
4000	-	4800		116	116	149	2	1,6
-	2400	-		116	116	149	2	1,6
3200	-	3800		117	117	178	2	3,7
-	2200	-		117	117	178	2	3,7
2800	-	3400		119	119	211	2,5	8,25
4300	-	5000	110	115	115	135	1	0,6
-	2600	-		115	115	135	1	0,6
3800	-	4500		119	119	161	2	1,95
-	2400	-		119	119	161	2	1,95
3000	-	3600		122	122	188	2	4,35
3800	-	4500	120	125	125	145	1	0,65
-	2400	-		125	125	145	1	0,65
3400	-	4000		129	129	171	2	2,05
-	2200	-		129	129	171	2	2,05
2800	-	3400		132	132	203	2	5,15
3600	-	4300	130	136	136	159	1	0,93
-	2200	-		136	136	159	1	0,93
3200	-	3800		139	139	191	2	3,15
-	2000	-		139	139	191	2	3,15
2600	-	3200		144	144	216	2,5	5,8

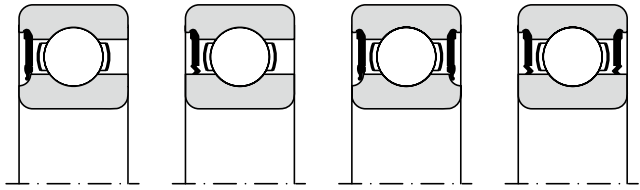
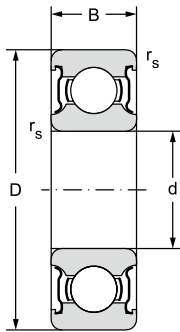

RS

RSR

ZRS

ZRSR

12.1.2

Main dimensions				Basic load rating		Fatigue load limit	Bearing designation	
d	D	B	r _s	Dynamic C _r	Static C _{st}	P _u	Z, ZR	2Z, 2ZR
mm				kN		kN	RS, RSR	2RS, 2RSR
140	175	18	1,1	39	46,5	1,66	-	61828-2ZR
	175	18	1,1	39	46,5	1,66	-	61828-2RSR
	210	33	2	111	108	3,45	6028-Z	6028-2Z
	210	33	2	111	108	3,45	6028-RSR	6028-2RSR
150	225	35	2,1	125	125	3,9	6030-Z	6030-2Z
	225	35	2,1	125	125	3,9	6030-RSR	6030-2RSR
160	240	38	2,1	143	143	4,3	6032-Z	6032-2Z
	240	38	2,1	143	143	4,3	6032-RSR	6032-2RSR

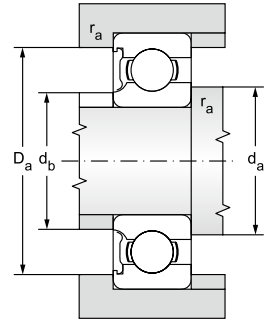
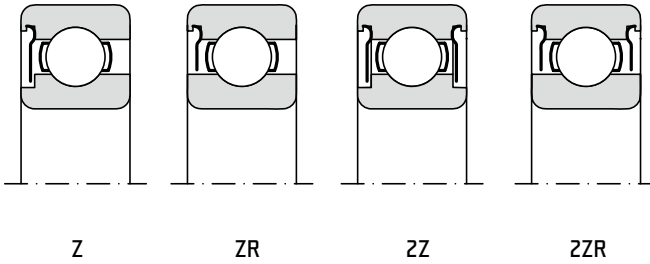

Limiting speed for lubrication with			Abutment and Fillet Dimensions					Weight
Grease		Oil	d	d _a	d _b	D _a	r _a	~
Z, 2Z	RS, 2RS	Z	min	max	max	max		
min ⁻¹			mm					kg
3400	-	4000	140	146	146	169	1	0,99
-	2000	-		146	146	169	1	0,99
3000	-	3600		149	149	201	2	3,35
-	1800	-		149	149	201	2	3,35
2600	-	3200	150	160	160	215	2	4,8
-	1700	-		160	160	215	2	4,8
2400	-	3000	160	169	169	231	2	5,9
-	1600	-		169	169	231	2	5,9

Single row ball bearings with groove for snap ring on outer race $d = 12$ to 120 mm

$d = 12$ to 45 mm

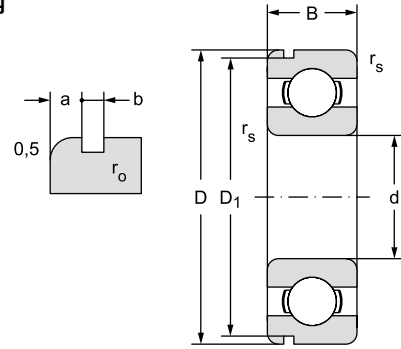

12.1.3

Main dimensions								Basic load rating		Fatigue load limit
d	D	B	r_s		a	b	r_o	Dynamic	Static	P_u
			min	max				C_r	C_{er}	
mm								kN		kN
12	32	10	0,66	30,15	2,06	1,35	0,4	6,905	3,100	0,141
	32	14	0,66	30,15	2,06	1,35	0,4	6,905	3,100	0,141
15	35	11	0,60	33,17	2,06	1,35	0,4	7,718	3,745	0,170
	35	14	0,60	33,17	2,06	1,35	0,4	7,718	3,745	0,170
17	40	12	0,60	38,10	2,06	1,35	0,4	9,534	4,734	0,215
	40	16	0,60	38,10	2,06	1,35	0,4	9,534	4,734	0,215
	47	14	1,00	44,60	2,46	1,35	0,4	13,565	6,563	0,298
20	42	12	0,60	39,75	2,06	1,35	0,4	9,371	4,972	0,226
	47	14	1,00	44,60	2,46	1,35	0,4	12,774	6,553	0,298
	52	15	1,10	49,73	2,46	1,35	0,4	15,866	7,811	0,355
	52	21	1,10	49,73	2,46	1,35	0,4	15,866	7,811	0,355
25	47	12	0,60	44,60	2,06	1,35	0,4	10,070	5,806	0,264
	52	15	1,00	49,73	2,46	1,35	0,4	14,029	7,940	0,361
	52	18	1,00	49,73	2,46	1,35	0,4	14,029	7,940	0,361
	62	17	1,10	59,61	3,28	1,90	0,6	21,123	10,806	0,491
	62	24	1,10	59,61	3,28	1,90	0,6	21,123	10,806	0,491
	80	21	1,50	76,81	3,28	1,90	0,6	36,000	19,200	0,873
30	55	13	1,00	52,60	2,08	1,90	0,4	13,243	8,253	0,375
	62	16	2,00	59,61	3,28	1,90	0,6	19,443	11,186	0,508
	62	20	2,00	59,61	3,28	1,90	0,6	19,443	11,186	0,508
	72	19	1,10	68,81	3,28	1,90	0,6	29,701	15,678	0,713
	90	23	1,50	86,79	3,28	2,70	0,6	43,000	23,700	1,077
35	62	14	1,00	59,61	2,06	1,90	0,6	15,956	10,328	0,469
	72	17	1,10	68,81	3,28	1,90	0,6	25,663	15,277	0,694
	80	21	1,50	78,81	3,28	1,90	0,6	33,367	19,230	0,874
	100	25	1,50	96,80	3,28	2,70	0,6	55,200	31,000	1,409
40	68	15	1,00	64,82	2,49	1,90	0,6	16,824	11,493	0,522
	80	18	1,10	76,81	3,28	1,90	0,6	32,633	19,887	0,904
	90	23	1,50	86,79	3,28	2,70	0,6	40,760	24,017	1,092
	110	27	2,00	106,81	3,28	2,70	0,6	63,100	36,200	1,645
45	75	16	1,00	71,83	2,49	1,90	0,6	21,100	15,300	0,695
	85	19	1,10	81,81	3,28	1,90	0,6	32,687	20,325	0,924
	100	25	1,50	96,80	3,28	2,70	0,6	52,804	31,715	1,442
	120	29	2,00	115,21	4,06	3,10	0,6	76,500	44,700	2,032

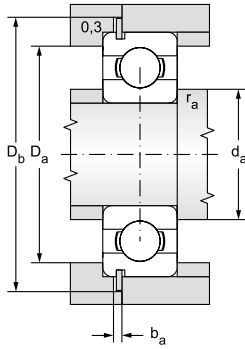

Limiting speed for lubrication with		Bearing designation	Abutment and Fillet Dimensions						Weight	Suitable snap ring
Grease	Oil		d	d _a	D _a	D _b	b _a	r _a		
		min ⁻¹		min	min	max	min	min	max	kg
mm										
22000	27000	6201N	12	16,0	28,0	39,0	1,4	0,6	0,037	R32
22000	27000	62201N		16,0	28,0	39,0	1,4	0,6	0,045	R32
20000	24000	6202N	15	19,0	31,0	41,0	1,4	0,6	0,030	R35
20000	24000	62202N		19,0	31,0	41,0	1,4	0,6	0,054	R35
18000	21000	6203N	17	21,0	36,0	46,0	1,5	0,6	0,073	R40
18000	21000	62203N		21,0	36,0	46,0	1,5	0,6	0,083	R40
16000	19000	6303N		23,0	41,0	54,0	1,5	1,0	0,12	R47
17000	20000	6004N	20	24,0	38,0	47,5	1,5	0,6	0,070	R42
15000	18000	6204N		25,0	42,0	54,0	1,5	1,0	0,11	R47
14000	17000	6304N		26,0	45,0	59,0	1,5	1,0	0,15	R52
14000	17000	62304N		26,0	45,0	59,0	1,5	1,0	0,20	R52
14000	17000	6005N	25	28,0	43,0	54,0	1,5	0,6	0,082	R47
12600	15000	6205N		30,0	47,0	59,0	1,5	1,0	0,13	R52
12600	15000	62205N		30,0	47,0	59,0	1,5	1,0	0,15	R52
11000	13000	6305N		31,0	55,0	69,0	2,2	1,0	0,23	R62
11000	13000	62305N		31,0	55,0	69,0	2,2	1,0	0,32	R62
9400	11000	6405N		34,0	70,0	88,0	2,2	1,5	0,53	R80
12000	14000	6006N	30	34,0	50,0	62,0	1,5	1,0	0,12	R55
11000	13000	6206N		35,0	57,0	69,0	2,2	1,0	0,20	R62
11000	13000	62206N		35,0	57,0	69,0	2,2	1,0	0,24	R62
10000	12000	6306N		36,0	65,0	80,0	2,2	1,0	0,33	R72
8400	10000	6406N		39,0	80,0	98,0	3,0	1,5	0,73	R90
10600	12600	6007N	35	39,5	57,0	69,0	2,2	1,0	0,15	R62
9400	11000	6207N		42,0	65,0	80,0	2,2	1,0	0,28	R72
8400	10000	6307N		42,0	71,0	88,0	2,2	1,5	0,45	R80
7500	8900	6407N		44,0	90,0	108,0	3,0	1,5	0,95	R100
9400	11000	6008N	40	44,0	63,0	76,0	2,2	1,0	0,19	R68
8400	10000	6208N		47,0	73,0	88,0	2,2	1,0	0,35	R80
7900	9400	6308N		47,0	81,0	98,0	3,0	1,5	0,63	R90
6700	7900	6408N		50,0	97,0	118,0	3,0	3,0	1,23	R110
8400	10000	6009N	45	49,0	70,0	83,0	2,2	1,0	0,24	R75
7900	9400	6209N		52,0	78,0	93,0	2,2	1,0	0,40	R85
7100	8400	6309N		52,0	91,0	108,0	3,0	1,5	0,83	R100
6000	7100	6409N		55,0	107,0	131,0	3,5	2,0	1,54	R120

Single row ball bearings with groove
for snap ring on outer race

d = 50 to 85 mm

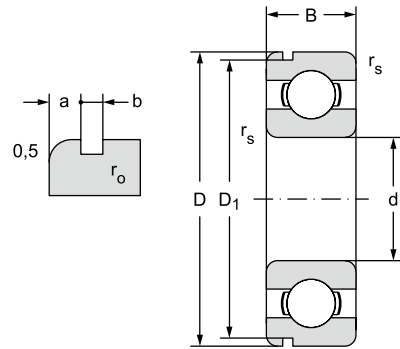

12.1.3

Main dimensions								Basic load rating		Fatigue load limit
d	D	B	r _s	D ₁	a	b	r ₀	Dynamic	Static	P _u
			min	max	max	min	max	C _r	C _{st}	P _u
mm								kN		kN
50	80	16	1,00	76,81	2,49	1,90	0,6	21,720	16,650	0,757
	90	20	1,10	86,79	3,28	2,70	0,6	35,066	23,226	1,056
	110	27	2,00	106,81	3,28	2,70	0,6	61,900	37,600	1,709
55	90	18	1,10	86,79	2,87	2,70	0,6	28,200	21,318	0,969
	100	21	1,50	96,80	3,28	2,70	0,6	43,350	29,397	1,336
	120	29	2,00	115,21	4,06	3,10	0,6	71,000	44,700	2,032
	140	33	2,10	135,23	4,90	3,10	0,6	100,000	61,900	2,814
60	95	18	1,10	91,82	2,87	2,70	0,6	29,343	23,256	1,057
	110	22	1,50	106,81	3,82	2,70	0,6	52,486	35,786	1,627
	130	31	2,10	125,22	4,06	3,10	0,6	81,500	52,100	2,368
	150	35	2,10	145,24	4,90	3,10	0,6	110,000	69,400	3,079
65	100	18	1,10	96,80	2,87	2,70	0,6	30,500	25,100	1,141
	120	23	1,50	115,21	4,06	3,10	0,6	57,210	40,011	1,819
	140	33	2,10	135,23	4,90	3,10	0,6	92,600	59,600	2,676
	160	37	2,10	155,22	4,90	3,10	0,6	117,950	78,329	3,357
70	110	20	1,10	106,81	2,87	2,70	0,6	37,960	30,959	1,407
	125	24	1,50	120,22	4,06	3,10	0,6	62,000	43,800	1,991
	150	35	2,10	145,24	4,90	3,10	0,6	104,000	68,100	2,951
	180	42	3,00	173,66	5,69	3,50	0,6	114,000	104,000	4,228
75	115	20	1,10	111,81	2,87	2,70	0,6	39,747	33,170	1,508
	130	25	1,50	125,22	4,06	3,10	0,6	66,170	49,311	2,214
	160	37	2,10	155,22	4,90	3,10	0,6	114,000	76,400	3,204
	190	45	3,00	183,64	5,69	3,50	0,6	152,529	112,922	4,459
80	125	22	1,10	120,22	2,87	3,10	0,6	47,500	39,800	1,787
	140	26	2,00	135,23	4,90	3,10	0,6	72,200	53,100	2,301
	170	39	2,10	163,65	5,69	3,50	0,6	122,850	86,226	3,506
	200	48	3,00	193,65	5,69	3,50	0,6	163,587	124,984	4,801
85	130	22	1,10	125,22	2,87	3,10	0,6	49,794	42,609	1,868
	150	28	2,00	145,24	4,90	3,10	0,6	83,299	63,675	2,670
	180	41	3,00	173,66	5,69	3,50	0,6	132,507	96,069	3,794

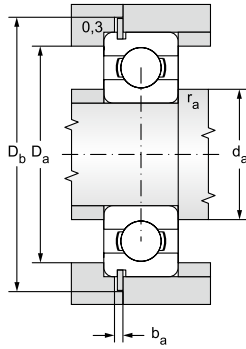

Limiting speed for lubrication with		Bearing designation	Abutment and Fillet Dimensions						Weight	Suitable snap ring
Grease	Oil		d	d _a	D _a	D _b	b _a	r _a		
		min ⁻¹		min	min	max	min	min	max	kg
mm										
7900	9400	6010N	50	54,0	75,0	88,0	2,2	1,0	0,26	R80
7100	8400	6210N		57,0	83,0	98,0	3,0	1,0	0,46	R90
6300	7500	6310N		60,0	100,0	118,0	3,0	2,0	1,06	R110
7100	8400	6011N	55	60,0	84,0	98,0	3,0	1,0	0,38	R90
6700	7900	6211N		62,0	91,0	108,0	3,0	1,5	0,60	R100
5600	6700	6311N		65,0	110,0	131,0	3,5	2,0	1,38	R120
5300	6300	6411N		68,0	126,0	151,0	3,5	2,0	2,29	R140
6700	7900	6012N	60	65,0	88,0	103,0	3,0	1,0	0,41	R95
6000	7100	6212N		67,0	101,0	110,0	3,0	1,5	0,77	R110
5300	6300	6312N		72,0	118,0	141,0	3,5	2,0	1,72	R130
4700	5600	6412N		73,0	136,0	162,0	3,5	2,0	2,76	R150
6300	7500	6013N	65	70,0	93,0	108,0	3,0	1,0	0,44	R100
5300	6300	6213N		72,0	111,0	131,0	3,5	1,5	1,00	R120
5000	6000	6313N		76,0	128,0	148,0	3,5	2,0	2,10	R140
4500	5300	6413N		78,0	146,0	172,0	3,5	2,0	3,28	R160
5600	6700	6014N	70	75,0	103,0	118,0	3,0	1,0	0,60	R110
5300	6300	6214N		77,0	116,0	136,0	3,5	1,5	1,07	R125
4700	5600	6314N		81,0	138,0	162,0	3,5	2,0	2,54	R150
4000	4700	6414N		85,0	164,0	195,0	4,5	2,5	4,85	R180
5300	6300	6015N	75	80,0	108,0	123,0	3,0	1,0	0,64	R115
5000	6000	6215N		82,0	121,0	141,0	3,5	1,5	1,18	R130
4200	5000	6315N		86,0	148,0	172,0	3,5	2,0	3,06	R160
3800	4500	6415N		90,0	174,0	205,0	4,5	2,5	5,74	R190
5000	6000	6016N	80	85,0	118,0	136,0	3,5	1,0	0,85	R125
4700	5600	6216N		90,0	130,0	151,0	3,5	2,0	1,40	R140
4000	4700	6316N		91,0	158,0	185,0	3,5	2,0	3,63	R170
3500	4200	6416N		95,0	184,0	215,0	4,5	2,5	6,72	R200
4700	5600	6017N	85	91,5	123,5	141,0	3,5	1,0	0,89	R130
4200	5000	6217N		95,0	140,0	162,0	3,5	2,0	1,80	R150
3800	4500	6317N		98,0	166,0	195,0	4,5	2,5	4,20	R180

Single row ball bearings with groove
for snap ring on outer race

d = 90 to 120 mm

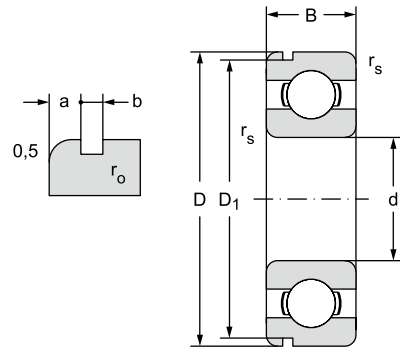

Main dimensions								Basic load rating		Fatigue load limit
d	D	B	r _s	D ₁	a	b	r _o	Dynamic C _r	Static C _{cr}	P _u
mm								kN		kN
90	140	24	1,50	135,23	3,71	3,10	0,6	58,400	49,200	2,085
	160	30	2,00	155,22	4,90	3,10	0,6	96,200	70,800	2,878
95	200	45	3,00	193,65	5,69	3,50	0,6	152,444	117,366	4,393
100	150	24	1,50	145,24	3,71	3,10	0,6	60,096	54,244	2,205
105	190	36	2,10	183,64	5,96	3,50	0,6	132,297	104,833	3,924
120	180	28	2,00	173,66	3,71	3,50	0,6	85,000	79,400	2,947

12.1.3

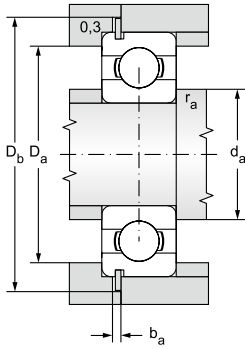

Limiting speed for lubrication with		Bearing designation	Abutment and Fillet Dimensions						Weight	Suitable snap ring
Grease	Oil		d	d _a	D _a	D _b	b _a	r _a		
		min ⁻¹		min	min	max	min	min	max	kg
4500	5300	6018N	90	96,0	132,0	151,0	3,5	1,5	1,17	R140
4000	4700	6218N		100,0	150,0	172,0	3,5	2,0	2,16	R160
3300	4000	6319N	95	109,0	186,0	215,0	4,5	2,5	5,72	R200
4200	5000	6020N	100	106,0	142,0	162,0	3,5	1,5	1,27	R150
3300	4000	6221N	105	117,0	178,0	205,0	4,5	2,0	3,74	R190
3300	4000	6024N	120	188,0	171,0	195,0	4,5	2,0	2,10	R180

Separable single row ball bearings d = 10 to 20 mm

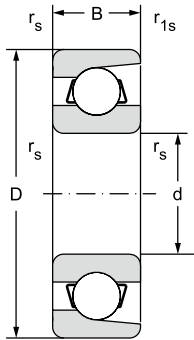

12.1.4

Main dimensions					Basic load rating		Fatigue load limit
d	D	B	r_s	r_{1s}	Dynamic	Static	
			min	min	C_r	C_{or}	P_u
mm					kN		kN
10	28	8	0,3	0,15	6,448	2,914	0,13
12	32	7	0,3	0,15	6,363	3,369	0,15
15	35	8	0,3	0,15	8,395	4,584	0,21
	35	8	0,3	0,15	8,395	4,584	0,21
17	44	11	0,6	0,30	10,713	6,077	0,28
	44	11	0,6	0,30	14,723	8,066	0,37
20	47	12	1,0	0,60	15,876	9,149	0,42

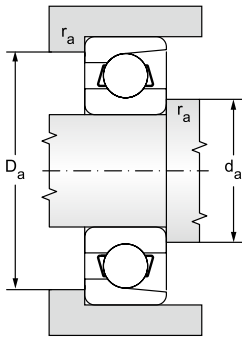

Limiting speed for lubrication with		Bearing designation	Abutment and Fillet Dimensions				Weight
Grease	Oil		d	d _a min	D _a max	r _a max	
min ⁻¹			mm				kg
25000	31000	E10Y	10	12,0	25,5	0,3	0,022
22000	28000	E12TNG	12	14,0	29,0	0,3	0,029
20000	24000	E15	15	17,2	31,8	0,3	0,034
20000	24000	E15Y		17,2	31,8	0,3	0,034
16000	19000	E17	17	22,0	39,0	0,6	0,079
14000	17000	B017		22,0	39,0	0,6	0,075
14000	17000	E20	20	26,0	42,0	1,0	0,089





12.2 ANGULAR CONTACT BALL BEARINGS



Angular contact ball bearings have raceways of bearing rings designed so that the joins of their contact points and balls contain sharp angle, the so-called contact angle, with the vertical line towards the axis. The bearings are non separable. Separable are some special bearings, or bearings with multipoint contact of QJ type. These bearings are suitable for transfer of combined loads, the so-called simultaneously acting radial and axial loads. With increasing contact angle the axial load bearing capacity grows whilst the radial load bearing capacity slowly reduced.

ZKL manufacture angular contact ball bearings in many versions and dimensions for use in general engineering. The chart section of the catalogue states the standard assortment of ZKL bearings with main dimensions and parameters divided as follows:

- Single row angular contact ball bearings
- Single row angular contact ball bearings for high revolution frequency
- Double row angular contact ball bearings
- Four Point Contact Ball Bearings

Single row angular contact ball bearings

Single row angular contact ball bearings are capable of transferring axial force only in one direction, and are not separable. B and BE design bearings have contact angle 40° . This design allows the bearing to capture radial load acting simultaneously with relatively big axial load in one direction. In order capture axial load in both direction bearings are mounted in pairs opposite each other. BE version bearings have modified inner design in order to transfer bigger load.

The production program includes bearings with contact angle 25° which have additional designation A, alternatively with 26° identified AA. These bearings are made in P5 and P4 accuracy levels, and are designed for location of machine tool and similar machine spindles with relatively higher axial load.

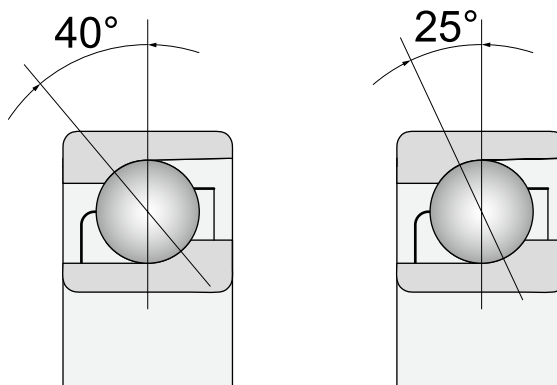

Fig. 12.2.1

SINGLE ROW ANGULAR CONTACT BALL BEARINGS FOR HIGH REVOLUTION FREQUENCY

Single row angular contact ball bearings of A70 and A72 type with symmetrical outer ring, or B70 and B72 with symmetrical inner ring are designed for high revolution frequencies. They differ from common bearings of this design group not only in the inner design of bearing raceways but also in the size of the contact angle, design of cage and high accuracy level.

C design bearings have contact angle 15° and are made in the P5, P5A and P4, P4A accuracy classes. They are used mostly for location of spindles of machine tools and similar equipment. CA design bearings have contact angle 12° . CB version bearings have contact angle 10° . They are usually made in the P4 and P4A accuracy level and are designed for very accurate locations with high revolution frequency, e.g. for electric grinding spindles and instruments.

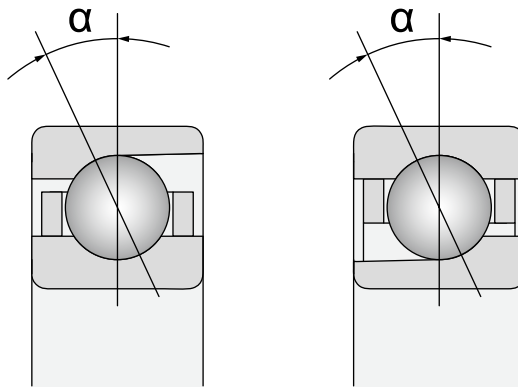

Fig. 12.2.2

Main dimensions

Main dimensions comply with the international standard ISO 15 and are stated in the table section.

Designation

The system of designating the bearings in basic version forms a part of the data stated in the table section. Difference from the basic design is identified with additional characters as advised in chapter 7.6. The characteristics of individual design variants are described below.

Cages

The 72 and 73 type bearings in B, BE and A versions are supplied with massive brass cage guided on rolling elements (M). Bearings can be also supplied with a sheet-metal cage that is not identified, or with a massive polyamide cage reinforced by glass fibres (TNG).

Bearings intended for high revolution frequencies are supplied with a massive cage of reinforced fabric – textit – guided on the outer ring (TA), or guided on the inner ring (TB). These bearings can be supplied even with a massive brass cage (M).



Accuracy

Single row 72 and 73 type angular contact ball bearings are usually made in normal accuracy level P0 whilst this symbol is not presented. For more exacting locations bearings are supplied in higher accuracy level P6 or P5.

Bearings intended for high revolutions are supplied in higher accuracy levels P5 and P4, alternatively P4A

The limit values of bearing dimension and run accuracy deviations comply with the standard ISO 492, and are stated in charts 7.2 and 7.3. Limit tolerance values for bearings of higher accuracies are stated in charts 7.4 to 7.8. Limit tolerance values of installation fillet are stated in chart 7.1. These values comply with the standard ISO 582.

Misalignment

Single row angular contact ball bearings can only balance misalignment to certain limited extent. The allowed misalignment of shaft against the element which does not cause inadmissibly high additional load depends on the service clearance in the bearing, size of bearings, inner design and forces and torques acting on the bearing. Considering unusually complex relations between individual factors, no generally applicable values can be stated. If bearings are mounted in pairs, especially in the arrangement with backs opposite one another (in the “O” layout) with small axial inner clearance, the misalignment can only be compensated by increased load of the balls that will cause higher stress of the cage and reduce the service durability of the bearings. More suitable for locations with small misalignment is the layout of bearings with fronts to each other (in the „X” layout) which has smaller rigidity in tilting. Any misalignment also causes increased noise level during the bearing run.

Association of bearings

The A70, A72, B70 and B72 version bearings designed for high revolution frequencies are supplied by the manufacturer associated in pairs, triplets or quaternions. Bearing can also be supplied as universally coupled.

Various arrangements of bearings are shown in the figure 12.2.3.

Associated pair “O”

Pair features high rigidity against misalignment and transfers axial forces in both directions through one bearing only. It is used to capture overturning torque.

Associated pair “X”

Pair has the same abilities in terms of transfer of axial forces as the “O” arrangement, but lower rigidity in capturing overturning torque.

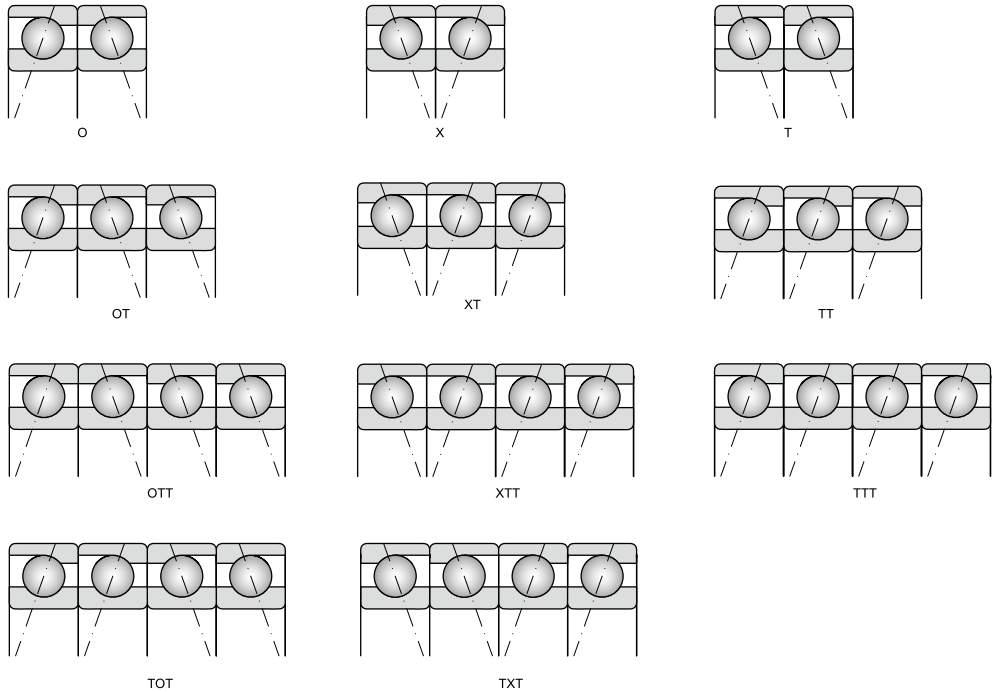

Fig. 12.2.3

Associated pair "T"

Pair features high rigidity in capturing overturning torque but is able to transfer axial load in one direction only.

Association of bearings in triplets and quaternions

For special locations that require high accuracy, rigidity, load bearing capacity and high revolution frequency, bearings of A70, A72, B70 and B72 type are supplied, combined in triplets and quaternions. The scheme of such arrangement is indicated in par. 2.2.

Considering the specifics of such cases, any use of the arrangement in triplets and quaternions should be discussed with the supplier.

Associated pair is supplied in a joint packaging in order to prevent confusion and the place of the biggest radial runout is for the assembly purposes marked with a punch mark on the face of rings. Mutual position of rings opposite each other is marked with concurring lines in "V" shape on the outer cylindrical surface of the associated pair. Bearings are mounted in location so that the punch marks identifying the place of the biggest radial runout are situated on the line that runs in parallel to the shaft axis.

Universal association of bearings



Bearings for universal pairing are produced in such tolerances that allow in any arrangement achieving of required prestress or tolerance without additional re-grinding of rings, or use of spacing washers. Additional identification of universal bearings contain the U symbol in combination with character that defines the final clearance or prestress range (UA2, UA, UA3, U0, UL, UM, US). Bearings can be arranged in location only in pairs of the same version. Thus, bearings can be mounted in tandems to capture bigger forces where one bearing is not enough; with the fronts or backs opposite each other.

Internal clearance and prestress

Usual method of use of single row angular contact ball bearings is in a pair where suitable service clearance or prestress are set during the assembly and depends on the construction of location and service conditions.

ZKL bearings intended for pairing are made for association with three clearance values, without clearance and three prestress values.

- A association of bearings with normal clearance
- A2 association of bearings with clearance smaller than normal
- A3 association of bearings with clearance bigger than normal
- 0 association of bearings without clearance
- L association of bearings with small prestress
- M association of bearings with medium prestress
- S association of bearings with big prestress

Size of internal clearance and prestress

Indicative values of axial prestress can be determined upon the below relation:

$$F_p = k C_r 10^{-2}$$

where:

- F_p axial prestress
- k coefficient of axial prestress according to table 12.2.1
- C_r radial dynamic load rating

Values of axial clearance of universally pairable bearings in pair with backs or front opposite each other are available in table 12.2.2

Table 12.2.1

Axial prestress		Coefficient K			
Size	Designation	Contact angle α			
		10°	12°	15°	26°
		Bearing design			
		CB	CA	C	AA
Small	L	0,4	0,5	0,7	1,2
Big	M	1,4	1,6	2	3,5
Big	S	2,8	3,2	4	7

Table 12.2.2

Bore diameter		Axial Internal clearance, Class					
d		A2		A		A3	
over	including	min	max	min	max	min	max
mm		μm					
10	18	5	13	15	23	24	32
18	30	7	15	18	26	32	40
30	50	9	17	22	30	40	48
50	80	11	23	26	38	48	60
80	120	14	26	32	44	55	67
120	180	17	29	35	47	62	74
180	250	21	37	45	61	74	90

Load rating of bearings mounted in pairs

The load bearing capacity values stated in tables apply to individual bearings. The following values apply to the use in pairs:

Dynamic load rating of pair in O or X arrangement: $C_{r2} = 1.62 C_{r1}$ (of individual bearing)

Dynamic load rating of pair in T arrangement: $C_{r2} = 2 C_{r1}$ (of individual bearing)

Static load capacity of pair $C_{or2} = 2 C_{or1}$ (of individual bearing)

Equivalent radial dynamic load

Bearings with contact angle of 40°



Individual bearings:

$$P_r = F_r \quad \text{for } F_a/F_r \leq 1.14$$

$$P_r = 0.35 F_r + 0.57 F_a \quad \text{for } F_a/F_r > 1.14$$

Bearings with contact angle of 25°

Individual bearings and associated bearings in T arrangement:

$$P_r = F_r \quad \text{for } F_a/F_r \leq 0.68$$

$$P_r = 0.41 F_r + 0.87 F_a \quad \text{for } F_a/F_r > 0.68$$

Associated pairs in O or X arrangement:

$$P_r = F_r + 0.92 F_a \quad \text{for } F_a/F_r \leq 0.68$$

$$P_r = 0.67 F_r + 1.14 F_a \quad \text{for } F_a/F_r > 0.68$$

Bearings with contact angle of 15°

Individual bearings and associated bearings in T arrangement:

$$P_r = F_r \quad \text{for } F_a/F_r \leq e$$

$$P_r = 0.44 F_r + Y F_a \quad \text{for } F_a/F_r > e$$

Associated pairs in O or X arrangement:

$$P_r = F_r + Y_1 F_a \quad \text{for } F_a/F_r \leq e$$

$$P_r = 0.72 F_r + Y_2 F_a \quad \text{for } F_a/F_r > e$$

F_r and F_a are forces acting on a pair of bearings. If the shaft is located in two single row angular contact ball bearings, the acting radial clearance will distribute to radial and axial component. Axial load of one bearing depends on the load and size of the contact angle of the second bearing. These additional inner forces must be considered in calculation of bearing.

Table 12.2.3

F_a/iC_{or}	e	Y
0,015	0,38	1,47
0,029	0,40	1,40
0,058	0,43	1,30
0,087	0,46	1,23
0,12	0,47	1,19
0,17	0,50	1,12
0,29	0,55	1,02
0,44	0,56	1,00
0,58	0,56	1,00

Table 12.2.4

F_a/iC_{or}	e	Y_1	Y_2
0,015	0,38	1,65	2,39
0,029	0,40	1,57	2,28
0,058	0,43	1,46	2,11
0,087	0,46	1,38	2,00
0,12	0,47	1,34	1,93
0,17	0,50	1,26	1,82
0,29	0,55	1,14	1,66
0,44	0,56	1,12	1,63
0,58	0,56	1,12	1,63

The below table states relations for different arrangements of bearings during acting of external axial force K_a , radial force F_{ra} or – more precisely – F_{rb} . Radial forces act in the point of intersection of joint line with the shaft axis. (Dimension “a” is in the table section.) The calculation considers the force intensity in absolute values only. The calculated force F_a is instituted in the calculation of equivalent radial dynamic load P_r .

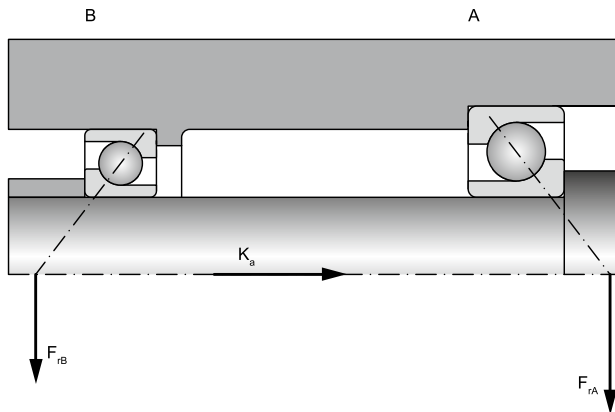

Fig. 12.2.7

Table 12.2.5

Arrangement of bearings	Force ratios	Axial load of bearings	
		Bearing A	Bearing B
See fig. 12.2.7 and 12.2.8	$F_{rA}/Y_A \leq F_{rB}/Y_B$ $K_a \geq 0$	$F_{aA} = F_{aB} + K_a$	$F_{aB} = e F_{rB}$
	$F_{rA}/Y_A > F_{rB}/Y_B$ $K_a \geq e (F_{rA} - F_{rB})$	$F_{aA} = F_{aB} + K_a$	$F_{aB} = e F_{rB}$
	$F_{rA}/Y_A > F_{rB}/Y_B$ $K_a < e (F_{rA} - F_{rB})^{1)}$	$F_{aA} = e F_{rA}$	$F_{aB} = F_{aA} - K_a$
See fig. 12.2.9 and 12.2.10	$F_{rA}/Y_A \geq F_{rB}/Y_B$ $K_a \geq 0$	$F_{aA} = e F_{rA}$	$F_{aB} = F_{aA} + K_a$
	$F_{rA}/Y_A < F_{rB}/Y_B$ $K_a < e (F_{rB} - F_{rA})$	$F_{aA} = e F_{rA}$	$F_{aB} = F_{aA} + K_a$
	$F_{rA}/Y_A < F_{rB}/Y_B$ $K_a < e (F_{rB} - F_{rA})^{1)}$	$F_{aA} = F_{aB} - K_a$	$F_{aB} = e F_{rB}$

¹⁾ Applies to $K_a = 0$
 For bearings with contact angle $\alpha = 40^\circ$ (BE a B) $e = 1,14$; $Y = 0,57$
 For bearings with contact angle $\alpha = 25^\circ$ (A) $e = 0,68$; $Y = 0,87$
 For other bearings e and Y accord. to tables 12.2.3 and 12.2.4

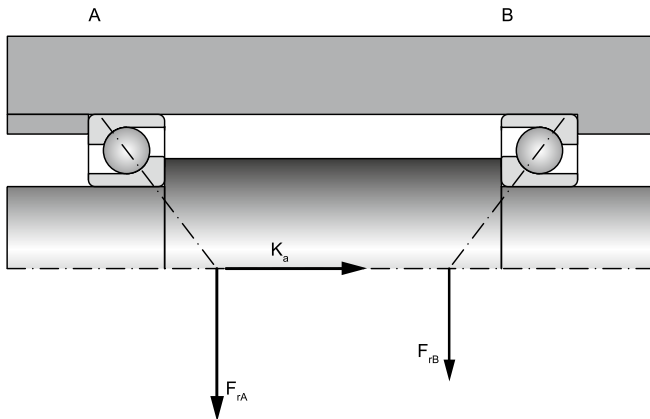

Fig. 12.2.8

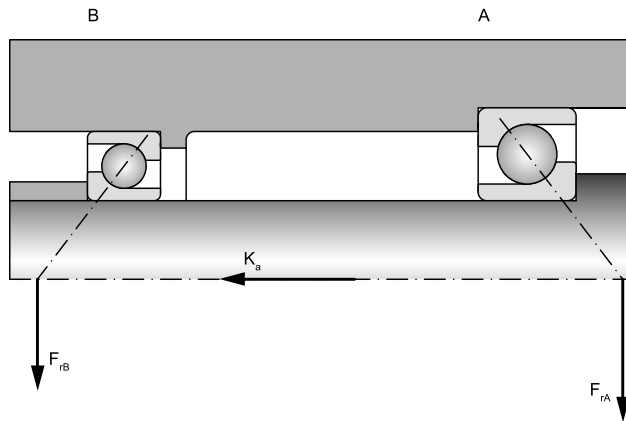

Fig. 12.2.9

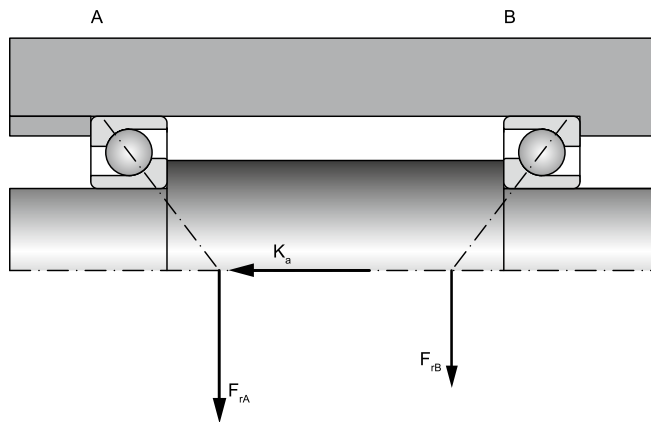

Fig. 12.2.10

Equivalent radial static load

The following applies to individual bearings and bearings mounted in tandem:

$$P_{0r} = 0.5 F_r + 0.26 F_a \quad \text{for } P_{0r} \geq F_r$$

$$P_{0r} = F_r \quad \text{for } P_{0r} < F_r$$

The following applies to bearings mounted in O or X arrangement:

$$P_{0r} = F_r + 0.52 F_a \quad \text{for } P_{0r} \geq F_r$$

$$P_{0r} = F_r \quad \text{for } P_{0r} < F_r$$

Location structure

Designing locations with single row angular contact ball bearings has to consider that these bearings must be used either with another bearing, or in pair. If single row angular contact ball bearings are used, they have to be arranged against each other to achieve the required prestress or clearance. If locations use bearings with universal pairing in contact next to each other, they need not be adjusted. Required prestress or clearance will be achieved by selecting a bearing of corresponding prestress or clearance class and proper location on the shaft and in the body. Proper adjustment and selection of prestress or clearance are essential for correct function of the bearing and reliability of location. If the service clearance is e.g. too big, then the bearing's load bearing capacity will not be fully utilised, whilst excessive prestress will cause high friction and higher service temperature which will lead to shorter service durability of the bearing. It however has to be emphasized that proper rolling of single row ball bearings of 72B and 73B series (with contact angle 40°) is only ensured in case that $F_a/F_r \geq 1$.

Special attention has to be paid to a pair of bearings mounted with their backs opposite each other (in the "O" arrangement), or with their fronts opposite each other (in the "X" arrangement), when axial load prevails in one direction. Incorrect rolling of unloaded bearing balls in these conditions might cause noise, interruption of grease film and increased stress of the cage. Under such conditions it is advisable to have zero service clearance which can be achieved e.g. by the use of thrust springs, or by pairing of bearings with adequate prestress sizes.



Single row angular contact ball bearings d = 10 to 240 mm

d = 10 to 45 mm

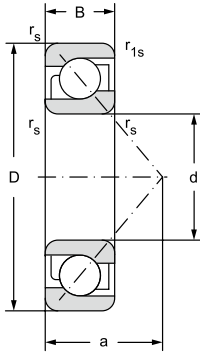

12.2.1

Main dimensions						Basic load rating		Fatigue load limit
d	D	B	r _s	r _{1s}	a	dynamic	static	P _u
			min	min		C _r	C _{or}	
mm						kN		kN
10	30	9	0,6	0,3	13,0	7,420	3,290	0,150
	30	9	0,6	0,3	13,0	7,020	3,350	0,140
12	32	10	0,6	0,3	14,0	8,030	3,780	0,172
	32	10	0,6	0,3	14,4	7,610	3,800	0,160
	37	12	1,0	0,6	16,3	10,600	5,000	0,208
15	35	11	0,6	0,3	12,0	9,580	4,880	0,222
	35	11	0,6	0,3	16,0	8,590	4,370	0,199
	42	13	1,0	0,6	18,0	13,900	6,580	0,299
	35	11	0,6	0,3	16,0	8,840	4,800	0,204
17	42	13	1,0	0,6	18,6	13,000	6,700	0,280
	47	14	1,0	0,6	15,0	16,600	7,890	0,359
	47	14	1,0	0,6	20,0	15,200	7,200	0,327
	47	14	1,0	0,6	20,0	16,300	8,000	0,364
20	47	14	1,0	0,6	15,0	16,400	8,540	0,388
	47	14	1,0	0,6	21,0	14,700	7,650	0,348
	47	14	1,0	0,6	21,0	16,700	8,650	0,393
	52	15	1,1	0,6	22,8	19,000	10,000	0,425
25	52	15	1,0	0,6	23,7	15,600	10,000	0,430
	62	17	1,1	0,6	27,0	26,800	14,600	0,664
	62	17	1,1	0,6	27,0	26,800	14,600	0,664
30	62	16	1,0	0,6	27,3	24,000	15,600	0,655
	72	19	1,1	0,6	31,0	35,500	21,200	0,900
35	72	17	1,1	0,6	31,0	31,000	20,800	0,880
	80	21	1,5	1,0	35,0	40,400	24,100	1,100
40	80	18	1,1	0,6	34,0	36,500	26,000	1,100
	90	23	1,5	1,0	39,0	50,000	32,500	1,370
45	85	19	1,1	0,6	37,0	38,000	28,500	1,220
	100	25	1,5	1,0	43,0	64,300	40,400	1,840
50	90	20	1,1	0,6	39,0	40,000	31,000	1,320
	110	27	2,0	1,0	47,0	75,000	51,000	2,160

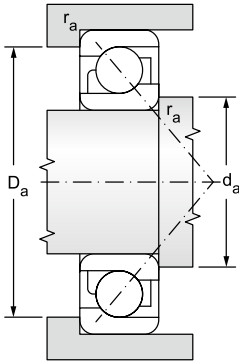

Limiting speed for lubrication with		Bearing designation	Abutment and Fillet Dimensions				Weight
Grease	Oil		d	d ₂	D _a	r _a	
min ⁻¹			mm				kg
21000	28000	7200BETNG	10	14,5	25,5	0,6	0,0
19000	28000	7200B		14,5	25,8	0,6	0,0
19000	26000	7201BETNG	12	16,5	27,5	0,6	0,0
18000	26000	7201B		16,2	27,8	0,6	0,0
17000	24000	7301B		17,6	31,4	1,0	0,1
17000	20000	7202AA	15	19,0	31,0	0,6	0,1
17000	20000	7202B		19,0	31,0	0,6	0,1
14000	17000	7302BETNG		21,0	36,0	1,0	0,1
15000	20000	7302B		20,6	36,4	1,0	0,1
15000	20000	7203B	17	21,2	35,8	0,6	0,1
12600	15000	7303AA		23,0	41,0	1,0	0,1
12600	15000	7303B		23,0	41,0	1,0	0,1
12600	15000	7303BTNG		23,0	41,0	1,0	0,1
12600	15000	7204AA	20	25,0	42,0	1,0	0,1
12600	15000	7204B		25,0	42,0	1,0	0,1
12600	15000	7204BTNG		25,0	42,0	1,0	0,1
11000	16000	7304B		27,0	45,0	1,0	0,1
10000	15000	7205B	25	30,6	46,4	1,0	0,1
9400	11000	7305B		31,0	55,0	1,0	0,2
10000	12500	7305BTNG		31,0	55,0	1,0	0,2
8500	12000	7206B	30	35,6	56,4	1,0	0,2
8000	11000	7306B		37,0	65,0	1,0	0,3
8000	11000	7207B	35	42,0	65,0	1,0	0,3
7100	8400	7307B		42,0	71,0	1,5	0,5
7000	9500	7208B	40	47,0	73,0	1,0	0,4
6700	9000	7308B		49,0	81,0	1,5	0,6
6700	9000	7209B	45	52,0	78,0	1,0	0,4
5600	6700	7309B		52,0	91,0	1,5	0,9
6000	8000	7210B	50	57,0	83,0	1,0	0,5
5300	7000	7310B		61,0	99,0	2,0	1,0

Single row angular contact ball bearings

d = 50 to 110 mm

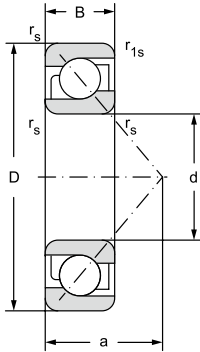

12.2.1

Main dimensions						Basic load rating		Fatigue load limit
d	D	B	r _s	r _{1s}	a	dynamic C _r	static C _{0r}	P _u
mm						kN		kN
55	100	21	1,5	1,0	29,5	58,100	40,500	1,840
	100	21	1,5	1,0	43,0	49,000	40,000	1,660
	120	29	2,0	1,0	51,0	87,000	56,400	2,560
60	110	22	1,5	1,0	32,0	70,100	50,600	2,300
	110	22	1,5	1,0	47,0	61,000	50,000	2,120
	130	31	2,1	1,0	55,0	104,000	76,500	3,200
65	120	23	1,5	1,0	50,0	66,300	54,000	2,280
	140	33	2,1	1,0	60,0	116,000	86,500	3,650
70	125	24	1,5	1,0	53,0	75,000	64,000	2,700
	150	35	2,1	1,0	64,0	127,000	98,000	3,900
75	130	25	1,5	1,0	56,0	72,800	64,000	2,650
	160	37	2,1	1,0	68,0	132,000	104,000	4,150
80	140	26	2,0	1,0	59,0	85,000	75,000	3,050
	170	39	2,1	1,0	72,0	143,000	118,000	4,500
85	150	28	2,0	1,0	63,0	102,000	90,000	3,550
	180	41	3,0	1,0	76,0	156,000	132,000	4,900
90	160	30	2,0	1,0	67,0	116,000	104,000	4,000
	190	43	3,0	1,0	80,0	166,000	146,000	5,300
95	170	32	2,1	1,0	72,0	129,000	118,000	4,400
	200	45	3,0	1,0	84,0	180,000	163,000	5,700
100	180	34	2,1	1,0	76,0	143,000	134,000	4,750
	215	47	3,0	1,0	90,0	216,000	208,000	6,950
105	190	36	2,1	1,0	80,0	156,000	150,000	5,200
	225	49	3,0	1,0	94,0	228,000	228,000	7,500
110	200	38	2,1	1,0	84,0	170,000	166,000	4,700
	240	50	3,0	1,0	99,0	240,000	245,000	7,800
120	215	40	2,1	1,0	90,0	165,000	163,000	5,300
	260	55	3,0	1,0	107,0	238,000	250,000	7,650

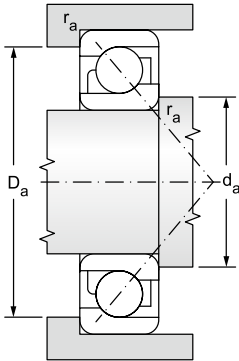

Limiting speed for lubrication with		Bearing designation	Abutment and Fillet Dimensions				Weight
Grease	Oil		d	d ₂	D _a	r _a	
min ⁻¹			mm				kg
5300	6300	7211AA	55	62,0	91,0	1,5	0,6
5600	7500	7211B		64,0	91,0	1,5	0,6
4700	5600	7311B		65,0	110,0	2,0	1,5
5000	6000	7212AA	60	67,0	101,0	1,5	0,8
5000	6700	7212B		69,0	101,0	1,5	0,8
4500	6000	7312B		72,0	118,0	2,0	1,7
4500	6000	7213B	65	74,0	111,0	1,5	1,0
4300	5600	7313B		77,0	128,0	2,0	2,1
4300	5600	7214B	70	79,0	116,0	1,5	1,1
3800	5000	7314B		82,0	138,0	2,0	2,6
4300	5600	7215B	75	84,0	121,0	1,5	1,2
3600	4800	7315B		87,0	148,0	2,0	3,1
3800	5000	7216B	80	91,0	129,0	2,0	1,4
3400	4500	7316B		92,0	158,0	2,0	3,6
3600	4800	7217B	85	96,0	139,0	2,0	1,8
3200	4300	7317B		99,0	166,0	2,5	4,3
3400	4500	7218B	90	101,0	149,0	2,0	2,1
3000	4000	7318B		104,0	176,0	2,5	5,0
3200	4300	7219B	95	107,0	158,0	2,0	2,7
2800	3800	7319B		109,0	186,0	2,5	5,8
3000	4000	7220B	100	112,0	168,0	2,0	3,3
2600	3600	7320B		114,0	201,0	2,5	7,2
2800	3800	7221B	105	117,0	178,0	2,0	3,8
2400	3400	7321B		119,0	211,0	2,5	8,5
2600	3600	7222B	110	122,0	188,0	2,0	4,6
2200	3200	7322B		124,0	226,0	2,5	9,7
2200	3200	7224B	120	132,0	203,0	2,0	5,9
1900	2800	7324BM		134,0	246,0	2,5	13,8

Single row angular contact ball bearings

d = 120 to 240 mm

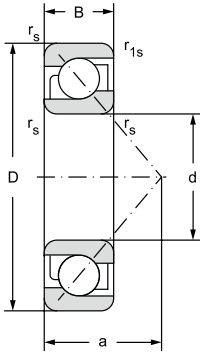

12.2.1

Main dimensions						Basic load rating		Fatigue load limit
d	D	B	r _s	r _{1s}	a	dynamic C _r	static C _{0r}	P _u
mm						kN		kN
130	230	40	3,0	1,0	96,0	186,000	193,000	6,100
	280	58	4,0	1,5	115,0	276,000	305,000	9,000
140	250	42	3,0	1,0	103,0	199,000	212,000	6,400
	300	62	4,0	1,5	123,0	302,000	345,000	9,800
150	270	45	3,0	1,0	111,0	216,000	240,000	6,950
	320	65	4,0	1,5	131,0	332,000	390,000	10,800
160	290	48	3,0	1,0	118,0	255,000	300,000	8,500
	360	72	4,0	1,5	147,0	390,000	490,000	12,700
170	310	52	4,0	1,5	127,0	281,000	345,000	9,500
	380	75	4,0	2,0	156,0	410,000	540,000	13,700
180	320	52	4,0	1,5	131,0	291,000	375,000	10,000
	400	78	5,0	2,0	164,0	442,000	600,000	14,600
190	340	55	4,0	1,5	139,0	307,000	405,000	10,400
	420	80	5,0	2,0	170,0	462,000	655,000	15,600
200	360	58	4,0	1,5	146,0	325,000	430,000	11,000
	440	72	4,0	1,5	180,0	364,000	540,000	12,500
220	400	65	4,0	1,5	164,0	390,000	560,000	13,400
	440	72	4,0	1,5	180,0	364,000	540,000	12,500

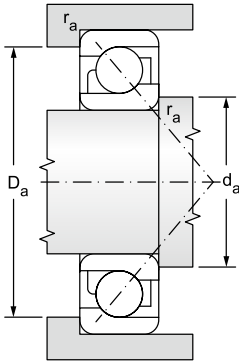

Limiting speed for lubrication with		Bearing designation	Abutment and Fillet Dimensions				Weight
Grease	Oil		d	d _a	D _a	r _a	
			min	max	max	~	
min ⁻¹			mm				kg
1900	2800	7226BM	130	144,0	216,0	2,5	6,8
1800	2600	7326BM		147,0	263,0	3,0	17,1
1800	2600	7228BM	140	154,0	236,0	2,5	8,6
1700	2400	7328BM		157,0	283,0	3,0	21,3
1700	2400	7230BM	150	164,0	256,0	2,5	10,8
1600	2200	7330BM		167,0	303,0	3,0	25,0
1600	2200	7232BM	160	174,0	276,0	2,5	13,6
1600	2200	7234BM	170	187,0	293,0	3,0	16,7
1400	1900	7334BM		187,0	343,0	3,0	34,6
1500	2000	7236BM	180	197,0	303,0	3,0	17,6
1300	1800	7336BM		197,0	363,0	3,0	40,0
1400	1900	7238BM	190	207,0	323,0	3,0	21,9
1200	1700	7338BM		210,0	380,0	4,0	48,3
1200	1700	7240BM	200	217,0	343,0	3,0	25,0
1100	1600	7340BM		220,0	400,0	4,0	52,8
1100	1600	7244BM	220	237,0	383,0	3,0	35,2
1000	1500	7248BM	240	257,0	423,0	3,0	49,0

Single row high-speed angular contact ball bearings d = 7 to 130 mm

d = 7 to 17 mm

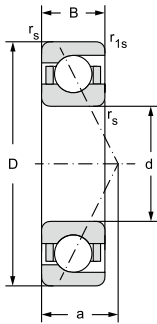

12.2.2

Main dimensions						Basic load rating		Fatigue load limit
d	D	B	r _s	r _{1s}	a	dynamic	static	P _u
			min	min		C _r	C _{or}	
mm						kN		kN
7	22	7	0,3	0,15	5,000	2,364	0,90	0,041
9	26	8	0,6	0,30	5,500	3,891	1,64	0,075
10	30	9	0,6	0,30	6,000	5,335	2,29	0,104
	30	9	0,6	0,30	6,500	7,124	2,90	0,132
	30	9	0,6	0,30	7,000	7,729	3,28	0,149
	30	9	0,6	0,30	7,180	4,387	2,10	0,095
	30	9	0,6	0,30	9,000	7,529	3,20	0,145
	30	9	0,6	0,30	9,160	4,181	2,00	0,091
12	32	10	0,6	0,30	7,000	5,880	2,65	0,120
	32	10	0,6	0,30	7,500	7,980	3,46	0,157
	32	10	0,6	0,30	8,000	8,622	3,89	0,177
	32	10	0,6	0,30	10,000	8,275	3,78	0,172
	32	10	0,6	0,30	10,500	7,505	3,21	0,146
15	32	9	0,3	0,15	7,648	4,695	2,30	0,105
	32	9	0,3	0,15	9,980	6,622	3,20	0,145
	32	9	0,3	0,15	9,980	4,490	2,20	0,100
	32	9	0,3	0,30	7,648	6,955	3,50	0,159
	35	11	0,6	0,30	7,500	6,940	3,45	0,157
	35	11	0,6	0,30	8,000	8,855	4,18	0,190
	35	11	0,6	0,30	11,000	9,078	4,44	0,202
	35	11	0,6	0,60	9,000	9,483	4,59	0,209
17	35	10	0,3	0,15	8,480	6,235	3,40	0,155
	35	10	0,3	0,15	16,780	7,562	4,25	0,193
	35	10	0,3	0,15	16,780	5,916	3,00	0,136
	35	10	0,3	0,30	8,480	7,896	4,45	0,202
	40	12	0,6	0,30	8,500	8,362	4,25	0,193
	40	12	0,6	0,30	9,000	10,904	5,29	0,240
	40	12	0,6	0,30	13,000	11,182	5,62	0,255
	40	12	0,6	0,60	10,000	11,631	5,82	0,265

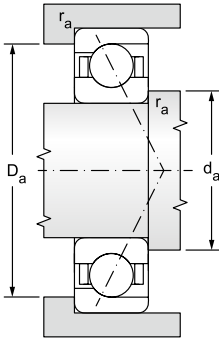

** Bearings in the new standard NEW FORCE
 *** Separable bearing dedicated to separable arrangements of textile spindles parts

Limiting speed for lubrication with		Axial prestress of associated bearings			Bearing designation	Weight
Grease	Oil	L	M	S		
min ⁻¹		N				kg
94000	140000				A727CBTA**	0,013
71000	106000				A729CBTA**	0,020
60000	89000	20	70	140	B7200CBTB**	0,027
42000	63000	33	105	213	B7200CATB**	0,028
56000	85000	45	140	280	B7200CTA**	0,030
65000	100000	15	60	130	CB7200CTA**	0,028
50000	75000	65	240	450	B7200ATA**	0,030
55000	85000	22	80	195	CB7200ATA**	0,028
56000	84000	22	77	154	B7201CBTB**	0,035
38000	56000	37	118	235	B7201CATB**	0,036
50000	75000	50	160	320	B7201CTA**	0,037
45000	67000	75	270	540	B7201ATA**	0,037
33000	50000				AC7201ATA***	0,036
55000	85000	11	52	115	CB7002CTA**	0,043
40000	65000	37	155	355	B7002ATA**	0,043
50000	72000	18	68	170	CB7002ATA**	0,043
45000	70000	30	110	225	B7002CTA**	0,043
50000	75000	25	90	180	B7202CBTB**	0,042
33000	50000	41	132	264	B7202CATB**	0,043
40000	60000	80	290	590	B7202ATA**	0,045
45000	67000	55	170	350	B7202CTA**	0,045
55000	80000	18	75	165	CB7003CTA**	0,039
38000	56000	50	190	420	B7003ATA**	0,039
45000	65000	30	100	230	CB7003ATA**	0,039
44000	67500	40	150	260	B7003CTA**	0,039
45000	67000	31	109	219	B7203CBTB**	0,060
28000	42000	51	163	326	B7203CATB**	0,061
36000	53000	100	360	730	B7203ATA**	0,064
38000	56000	70	210	430	B7203CTA**	0,064

Single row high-speed angular contact ball bearings

d = 20 to 35 mm

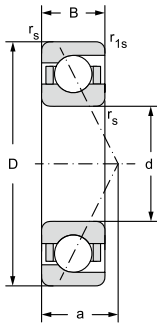

12.2.2

Main dimensions						Basic load rating		Fatigue load limit
d	D	B	r _s	r _{1s}	a	dynamic	static	P _u
			min	min		C _r	C _{or}	
mm						kN		kN
20	42	12	0,6	0,30	9,150	11,899	6,20	0,282
	42	12	0,6	0,30	9,150	7,940	4,20	0,191
	42	12	0,6	0,30	12,220	11,707	6,00	0,273
	42	12	0,6	0,30	12,220	7,740	4,00	0,182
	47	14	1,0	0,60	10,000	10,224	5,54	0,252
	47	14	1,0	0,60	10,500	14,572	7,32	0,333
	47	14	1,0	0,60	12,000	15,685	8,06	0,366
	47	14	1,0	0,60	14,000	14,952	7,77	0,353
	47	14	1,0	0,60	15,000	13,897	6,99	0,318
	25	47	12	0,6	0,30	10,320	13,750	8,60
47		12	0,6	0,30	10,320	9,532	5,70	0,259
47		12	0,6	0,30	13,890	13,186	8,20	0,373
47		12	0,6	0,30	13,890	9,121	5,60	0,255
52		15	1,0	0,60	11,000	14,091	7,96	0,362
52		15	1,0	0,60	11,500	15,921	8,63	0,392
52		15	1,0	0,60	13,000	17,679	10,28	0,467
52		15	1,0	0,60	16,000	16,917	9,81	0,446
52		15	1,0	0,60	17,000	14,895	8,15	0,370
30		55	13	1,0	0,60	12,200	16,234	10,30
	55	13	1,0	0,60	12,200	11,331	7,20	0,327
	55	13	1,0	0,60	25,850	15,515	10,10	0,459
	55	13	1,0	0,60	25,850	10,817	6,90	0,314
	62	16	1,0	0,60	12,000	18,020	10,72	0,487
	62	16	1,0	0,60	13,000	22,072	12,42	0,565
	62	16	1,0	0,60	14,000	24,734	14,72	0,669
	62	16	1,0	0,60	19,000	20,877	11,58	0,526
	62	16	1,0	0,60	19,000	23,483	14,07	0,640
	35	62	14	1,0	0,60	13,490	20,680	14,40
62		14	1,0	0,60	13,490	14,298	10,00	0,455
62		14	1,0	0,60	18,500	18,476	12,05	0,548
62		14	1,0	0,60	28,980	20,097	13,25	0,602
62		14	1,0	0,60	28,980	13,910	9,40	0,427
72		17	1,1	0,60	10,000	29,131	17,40	0,791
72		17	1,1	0,60	13,000	22,523	14,34	0,652
72		17	1,1	0,60	14,000	31,042	18,60	0,845
72		17	1,1	0,60	15,000	32,929	20,29	0,922
72		17	1,1	0,60	16,000	32,669	20,04	0,911
72		17	1,1	0,60	21,000	31,002	19,10	0,868

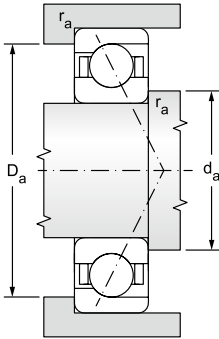

** Bearings in the new standard NEW FORCE

Limiting speed for lubrication with		Axial prestress of associated bearings			Bearing designation	Weight
Grease	Oil	L	M	S		
min ⁻¹		N				kg
39000	57000	55	180	400	B7004CTA**	0,066
45000	65000	25	100	200	CB7004CTA**	0,066
35000	50000	75	290	645	B7004ATA**	0,066
35000	55000	30	120	300	CB7004ATA**	0,066
40000	60000	38	134	268	B7204CBTB**	0,098
25000	38000	68	218	437	B7204CATB**	0,100
32000	48000	90	290	580	B7204CTA**	0,10
30000	45000	140	490	950	B7204ATA**	0,10
22000	33000	156	455	910	B7204AATB**	0,10
35000	50000	65	220	470	B7005CTA**	0,080
40000	55000	30	120	250	CB7005CTA**	0,080
30000	45000	100	360	740	B7005ATA**	0,080
35000	50000	35	180	410	CB7005ATA**	0,080
33000	50000	53	183	367	B7205CBTB**	0,12
22000	33000	74	237	474	B7205CATB**	0,12
28000	43000	100	330	650	B7205CTA**	0,13
26000	40000	155	550	1100	B7205ATA**	0,13
20000	30000	167	488	977	B7205AATB**	0,12
26000	40000	75	260	555	B7006CTA**	0,12
30000	45000	37	140	300	CB7006CTA**	0,12
24000	38000	105	405	885	B7006ATA**	0,12
28000	43000	40	200	450	CB7006ATA**	0,12
28000	42000	67	235	470	B7206CBTB**	0,18
20000	30000	102	325	655	B7206CATB**	0,19
24000	38000	140	450	910	B7206CTA**	0,19
17000	25000	233	679	1740	B7206AATB**	0,19
22000	36000	220	770	1530	B7206ATA**	0,19
22000	36000	100	330	710	B7007CTA**	0,16
30000	45000	48	180	380	CB7007CTA**	0,16
9400	11000	207	605	1210	B7007AATB**	0,15
20000	32000	140	530	1150	B7007ATA**	0,16
25000	40000	60	270	600	CB7007ATA**	0,16
13000	20000	326	952	1900	B7207AATB**	0,28
25000	38000	84	280	588	B7207CBTB**	0,27
16000	24000	144	462	925	B7207CATB**	0,28
16000	24000	153	490	981	B7207CAMB**	0,32
20000	34000	185	600	1200	B7207CTA**	0,28
19000	32000	290	1010	2010	B7207ATA**	0,28

Single row high-speed angular contact ball bearings

d = 40 to 55 mm

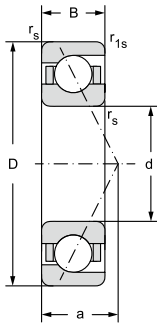

12.2.2

Main dimensions						Basic load rating		Fatigue load limit
d	D	B	r _s	r _{1s}	a	dynamic	static	P _u
			min	min		C _r	C _{or}	
mm						kN		kN
40	68	15	1,0	0,60	14,730	21,960	16,10	0,732
	68	15	1,0	0,60	14,730	15,151	11,00	0,500
	68	15	1,0	0,60	20,100	20,933	15,20	0,691
	68	15	1,0	0,60	20,100	14,111	10,60	0,482
	68	15	1,0	0,60	20,500	19,859	14,13	0,642
	80	18	1,1	0,60	14,000	26,240	17,30	0,786
	80	18	1,1	0,60	15,500	39,375	23,77	1,080
	80	18	1,1	0,60	17,000	41,450	26,02	1,183
	80	18	1,1	0,60	23,000	39,759	24,90	1,132
	45	68	12	0,6	0,30	13,000	16,018	12,60
68		12	0,6	0,30	13,000	11,502	9,10	0,414
68		12	0,6	0,30	18,190	15,137	12,00	0,545
68		12	0,6	0,30	18,190	10,777	8,80	0,400
75		16	1,0	0,60	0,030	27,020	20,40	0,927
75		16	1,0	0,60	16,030	18,921	14,30	0,650
75		16	1,0	0,60	21,980	25,680	19,30	0,877
75		16	1,0	0,60	21,980	17,993	13,50	0,614
85		19	1,1	0,60	15,000	30,327	20,31	0,923
85		19	1,1	0,60	16,500	39,540	24,61	1,119
50	80	16	1,0	0,60	15,800	24,133	18,52	0,842
	80	16	1,0	0,60	19,730	27,716	21,80	0,991
	80	16	1,0	0,60	19,730	19,740	15,30	0,695
	80	16	1,0	0,60	23,150	26,273	20,80	0,945
	80	16	1,0	0,60	23,150	18,708	14,60	0,664
	90	20	1,1	0,60	16,000	34,593	23,56	1,071
	90	20	1,1	0,60	17,500	41,758	27,26	1,239
	90	20	1,1	0,60	19,000	45,871	31,73	1,442
	90	20	1,1	0,60	26,000	39,229	25,92	1,178
	90	20	1,1	0,60	26,000	43,970	30,08	1,367
55	90	18	1,1	0,60	26,500	33,314	25,38	1,154
	100	21	1,5	1,00	17,000	41,229	29,12	1,324
	100	21	1,5	1,00	18,500	51,719	34,50	1,568
	100	21	1,5	1,00	21,000	56,847	39,92	1,815
	100	21	1,5	1,00	29,000	54,288	38,23	1,738

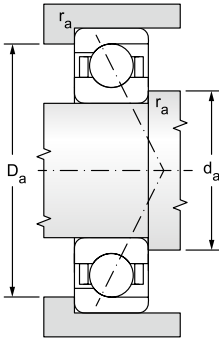

** Bearings in the new standard NEW FORCE

Limiting speed for lubrication with		Axial prestress of associated bearings			Bearing designation	Weight
Grease	Oil	L	M	S		
min ⁻¹		N				kg
20000	34000	105	350	755	B7008CTA**	0,19
26000	40000	50	190	410	CB7008CTA**	0,19
19000	30000	150	560	1200	B7008ATA**	0,19
22000	35000	60	280	630	CB7008ATA**	0,19
8400	10000	222	645	1290	B7008AATB**	0,19
22000	33000	98	343	686	B7208CBTB**	0,34
13000	20000	180	587	1170	B7208CATB**	0,35
18000	30000	235	770	1540	B7208CTA**	0,35
17000	28000	370	1100	2500	B7208ATA**	0,35
20000	32000	90	320	535	B71909CTA**	0,13
25000	38000	35	140	310	CB71909CTA**	0,11
18000	30000	100	390	840	B71909ATA**	0,13
22000	35000	70	200	450	CB71909ATA**	0,11
18000	30000	140	470	935	B7009CTA**	0,26
23000	37000	70	250	530	CB7009CTA**	0,23
17000	28000	195	750	1500	B7009ATA**	0,26
21000	33000	85	370	840	CB7009ATA**	0,23
20000	30000	113	396	792	B7209CBTB**	0,38
12600	19000	184	590	1175	B7209CATB**	0,38
17000	28000	250	810	1630	B7209CTA**	0,39
15000	24000	390	1200	2710	B7209ATA**	0,39
9500	11000	270	793	1580	B7010AATB**	0,25
17000	28000	150	510	965	B7010CTA**	0,25
22000	35000	75	280	580	CB7010CTA**	0,21
15000	24000	210	750	1550	B7010ATA**	0,25
18000	30000	90	400	880	CB7010ATA**	0,21
18000	27000	129	450	905	B7210CBTB**	0,43
12000	18000	195	623	1245	B7210CATB**	0,44
16000	26000	260	850	1710	B7210CTA**	0,45
10600	16000	438	1275	2550	B7210AATB**	0,45
14000	20000	400	1400	2810	B7210ATA**	0,45
6300	7500	371	1080	2160	B7011AATB**	0,40
17000	25000	153	538	1075	B7211CBTB**	0,57
11000	17000	241	771	1540	B7211CATB**	0,58
14000	22000	320	1010	2100	B7211CTA**	0,59
13000	20000	500	1710	3500	B7211ATA**	0,59

Single row high-speed angular contact ball bearings

d = 60 to 80 mm

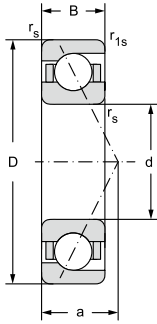

12.2.2

Main dimensions						Basic load rating		Fatigue load limit
d	D	B	r _s	r _{1s}	a	dynamic	static	P _u
			min	min		C _r	C _{or}	
mm						kN		kN
60	95	18	1,1	1,00	21,660	38,610	32,00	1,455
	95	18	1,1	1,00	21,660	27,085	22,40	1,018
	95	18	1,1	1,00	27,100	36,807	30,40	1,382
	95	18	1,1	1,00	27,100	25,810	21,30	0,968
	110	22	1,5	1,00	18,000	47,450	33,80	1,536
	110	22	1,5	1,00	20,000	64,377	42,60	1,936
	110	22	1,5	1,00	22,000	70,784	49,07	2,230
	110	22	1,5	1,00	31,000	67,627	47,07	2,140
	110	22	1,5	1,00	32,000	60,741	39,96	1,816
	65	120	23	1,5	1,00	21,500	78,185	54,78
120		23	1,5	1,00	24,000	81,130	58,70	2,668
120		23	1,5	1,00	33,000	76,670	56,06	2,548
70	110	20	1,1	0,60	22,060	53,288	45,00	2,045
	110	20	1,1	0,60	22,060	36,807	31,20	1,418
	110	20	1,1	0,60	30,990	50,628	42,90	1,950
	110	20	1,1	0,60	32,000	45,430	36,46	1,657
	125	24	1,5	1,00	20,500	64,709	47,66	2,166
	125	24	1,5	1,00	22,500	84,775	60,13	2,733
	125	24	1,5	1,00	25,000	87,597	64,55	2,934
	125	24	1,5	1,00	30,990	35,567	21,80	0,991
	125	24	1,5	1,00	35,000	83,397	61,56	2,798
75	130	25	1,5	1,00	23,500	84,948	61,39	2,756
	130	25	1,5	1,00	26,000	87,285	65,44	2,938
	130	25	1,5	1,00	36,000	83,103	62,52	2,807
	130	25	1,5	1,00	37,500	82,540	62,49	2,806
	130	25	1,5	1,00	37,500	78,887	58,32	2,618
80	125	22	1,1	0,60	22,000	61,117	50,01	2,245
	125	22	1,1	0,60	24,730	66,963	57,50	2,582
	125	22	1,1	0,60	24,730	46,894	40,20	1,805
	125	22	1,1	0,60	34,900	64,095	55,10	2,474
	125	22	1,1	0,60	34,900	44,874	38,60	1,733
	125	22	1,1	0,60	36,000	59,265	49,44	2,220
	140	26	2,0	1,00	24,500	99,345	73,05	3,166
	140	26	2,0	1,00	28,000	102,080	77,56	3,361
	140	26	2,0	1,00	39,000	97,328	73,95	3,205
	140	26	2,0	1,00	40,000	92,645	68,04	2,949

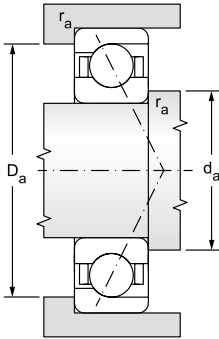

** Bearings in the new standard NEW FORCE

Limiting speed for lubrication with		Axial prestress of associated bearings			Bearing designation	Weight
Grease	Oil	L	M	S		
min ⁻¹		N				kg
14000	22000	210	700	1305	B7012CTA**	0,41
18000	30000	100	360	780	CB7012CTA**	0,35
13000	20000	290	1000	2100	B7012ATA**	0,41
15000	25000	130	540	1150	CB7012ATA**	0,35
15000	22000	172	602	1200	B7212CBTB**	0,74
10000	15000	291	932	1860	B7212CATB**	0,75
13000	20000	380	1200	2500	B7212CTA**	0,75
12000	19000	610	2130	4200	B7212ATA**	0,75
8900	13000	657	1915	3830	B7212AATB**	0,76
8900	13000	352	1128	2250	B7213CATB**	0,99
12000	19000	440	1400	2900	B7213CTA**	1,00
11000	18000	700	2410	4810	B7213ATA**	1,00
13000	19000	280	930	1825	B7014CTA**	0,60
15000	25000	140	500	1020	CB7014CTA**	0,50
11000	17000	390	1390	2910	B7014ATA**	0,60
7900	12000	493	1140	2050	B7014AATB**	0,60
12600	19000	234	820	1640	B7214CBTB**	1,04
7900	12000	373	1190	2350	B7214CATB**	1,07
11000	18000	480	1540	3170	B7214CTA**	1,09
14000	20000	180	720	1600	CB7014ATA**	0,50
10000	17000	760	2620	5300	B7214ATA**	1,09
7500	11000	383	1250	2450	B7215CATB**	1,16
11000	18000	480	1560	3170	B7215CTA**	1,17
9500	16000	760	2640	5210	B7215ATA**	1,17
4200	5000	898	2620	5240	B7215AAMB**	1,39
6700	10000	858	2500	500	B7215AATB**	1,26
7500	11000	276	885	1770	B7016CATB**	0,84
10000	18000	350	1140	2290	B7016CTA**	0,85
14000	22000	180	620	1350	CB7016CTA**	0,71
9000	15000	500	1800	3700	B7016ATA**	0,85
13000	20000	250	950	1950	CB7016ATA**	0,71
6700	10000	267	855	1710	B7016AATB**	0,85
6700	10000	447	1432	2860	B7216CATB**	1,41
10000	17000	560	1840	3700	B7216CTA**	1,43
9000	15000	880	3050	6110	B7216ATA**	1,43
6300	9400	1008	2940	5880	B7216AATB**	1,42

Single row high-speed angular contact ball bearings

d = 85 to 130 mm

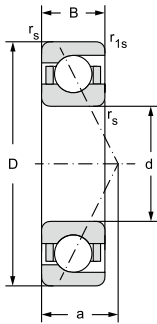

12.2.2

Main dimensions						Basic load rating		Fatigue load limit
d	D	B	r _s	r _{1s}	a	dynamic	static	P _u
			min	min		C _r	C _{or}	
mm						kN		kN
85	130	22	1,1	0,60	25,400	68,386	58,70	2,573
	130	22	1,1	0,60	25,400	47,914	41,40	1,815
	130	22	1,1	0,60	30,060	67,847	58,20	2,552
	130	22	1,1	0,60	30,060	47,558	40,70	1,784
	130	22	1,1	0,60	37,000	60,265	52,69	2,310
	130	28	1,1	0,60	37,000	62,314	55,33	2,426
	150	28	2,0	1,00	26,500	111,477	86,08	3,610
	150	28	2,0	1,00	30,000	115,662	88,55	3,713
90	140	24	1,5	1,00	24,000	74,528	62,47	2,648
	140	24	1,5	1,00	27,410	81,622	72,40	3,069
	140	24	1,5	1,00	27,410	57,187	57,90	2,454
	140	24	1,5	1,00	38,810	77,461	69,00	2,925
	140	24	1,5	1,00	38,810	54,305	40,50	1,717
	140	24	1,5	1,00	40,000	72,276	61,75	2,617
	180	34	2,1	1,10	51,000	156,339	120,96	4,732
	100	150	24	1,5	0,60	28,750	89,607	80,80
150		24	1,5	0,60	28,750	61,827	55,70	2,265
150		24	1,5	0,60	41,150	84,040	76,40	3,106
150		24	1,5	0,60	41,150	58,023	52,70	2,143
180		34	2,1	1,10	35,760	105,682	86,00	3,304
180		34	2,1	1,10	36,000	171,671	136,01	5,225
180		34	2,1	1,10	49,770	98,808	83,00	3,189
180		34	2,1	1,10	50,000	164,214	129,98	4,993
110	140	16	1,0	0,60	24,700	44,428	49,60	2,017
	140	16	1,0	0,60	34,000	42,287	46,30	1,882
120	180	28	2,0	1,00	30,000	112,019	103,66	3,847
	180	28	2,0	1,00	34,100	114,338	107,80	4,001
	180	28	2,0	1,00	34,100	78,921	75,40	2,798
	180	28	2,0	1,00	48,980	107,543	102,10	3,789
	180	28	2,0	1,00	48,980	74,299	71,50	2,654
	180	28	2,0	1,00	50,500	106,191	101,28	3,759
130	165	11	1,0	0,50	41,500	14,903	19,10	0,715

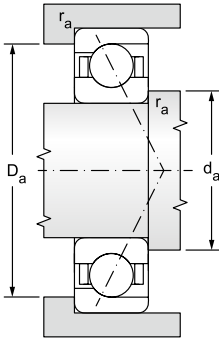

** Bearings in the new standard NEW FORCE

Limiting speed for lubrication with		Axial prestress of associated bearings			Bearing designation	Weight
Grease	Oil	L	M	S		
min ⁻¹		N				kg
10000	17000	380	1240	2350	B7017CTA**	0,91
12000	19000	190	640	1400	CB7017CTA**	0,77
9000	15000	540	1870	3900	B7017ATA**	0,91
10000	18000	260	1000	2100	CB7017ATA**	0,77
4200	5000	653	1900	3800	B7017AATA**	0,91
6300	9400	675	1970	3940	B7017AAMB**	1,06
6300	9400	502	1608	3210	B7217CATB**	1,80
9000	15000	630	2010	4150	B7217CTA**	1,82
8000	13000	1000	3450	6910	B7217ATA**	1,82
6000	8900	1310	3290	6590	B7217AATB**	1,82
6300	9400	338	1080	2160	B7018CATB**	1,15
10000	16000	450	1450	2800	B7018CTA**	1,15
12000	19000	230	760	1590	CB7018CTA**	0,97
9000	15000	620	2200	4580	B7018ATA**	1,15
10000	17000	315	1150	2550	CB7018ATA**	0,97
4000	4700	783	2280	4570	B7018AATB**	1,16
5300	7900	1690	4930	9870	B7220AATB**	3,32
8000	14000	470	1520	3070	B7020CTA**	1,29
11000	18000	235	815	1700	CB7020CTA**	1,10
7000	12000	680	2340	4950	B7020ATA**	1,29
9000	15000	335	1265	2710	CB7020ATA**	1,10
10000	15000	450	1460	2950	CB7220CTA**	2,89
7500	12000	940	3100	6220	B7220CTA**	3,32
8000	13000	640	2200	5580	CB7220ATA**	2,89
6700	10000	1480	5200	10100	B7220ATA**	3,32
8000	13000	200	700	1500	B71822CTA**	0,50
7000	11000	350	900	2000	B71822ATA**	0,50
5000	7500	505	1617	3230	B7024CATB**	2,10
7000	10000	670	2000	4100	B7024CTA**	2,10
9000	14000	320	1100	2220	CB7024CTA**	1,85
6000	9000	950	3200	6550	B7024ATA**	2,10
8000	12000	450	1680	3550	CB7024ATA**	1,85
3000	3500	1153	3363	6727	B7024AATB**	2,09
3200	3800				B70826AAMB**	0,64

DOUBLE ROW ANGULAR CONTACT BALL BEARINGS

Design

Double row angular contact ball bearings in fact correspond with associated pair of single row angular contact ball bearings in configuration "0". At the same size (d and D), associated pair has total width smaller.

They can transfer radial load and also double direction axial loads. Bearings allow design of rigid location and transfer also overturning torques. Standard offer of ZKL double row angular contact ball bearings (fig. 12.2.4) includes:

- Bearings in standard version
- Bearings with seals

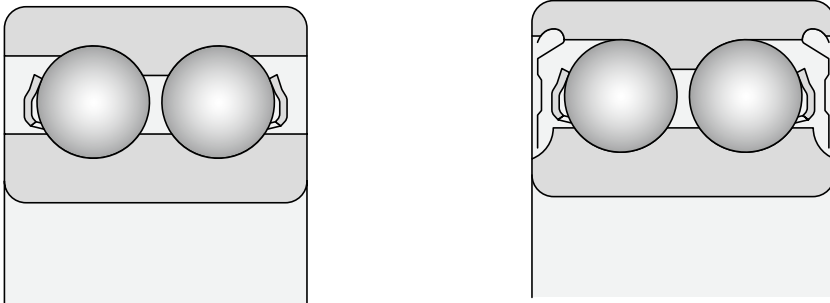

Fig. 12.2.4

Bearings in standard version

ZKL double row angular contact ball bearings in fact of 32 and 33 series produced in the NEW FORCE standard are marked with ** in the table section. The bearings feature optimised inner design. They have a filling slot on one side. If axial forces acting in one direction prevail, the bearing should be mounted so that these forces do not act against the filling slot.

The bearings have contact angle of 32° . Due to this design they are able to transfer axial load and higher overturning torques in axial plane so if there is a lack of space, only one bearing is enough for location of the rotary part.

Bearings with seals

The bearings have a design with contact angle of 25°. The 32 and 33 series bearings with sealing 2RS are filled with high quality lithium grease Shell Gadus F2V100-3. This grease features good anticorrosive properties, and can be therefore used in temperature ranging between -30 and 20 °C. The viscosity of basic oil compound is 100 mm²/s at 40 °C or 10. mm²/s at 100 °C.

Main dimensions

The main dimensions of the bearings comply with the ISO 15 standard, with the exception of the width of bearing 3200X. Dimensions of individual bearings are stated in the table section of the publication.

Designation

The system of designating the bearings in basic version is stated in the table section of the publication. Difference from the basic design is identified with additional characters as advised in chapter 7.6.

Cages

Double row angular contact ball bearings have cages pressed of steel plate (fig. 12.2.5). The design not identified. Bearings can be also supplied with polyamide cage PA6 or PA66, designated TNG (fig. 12.2.6)

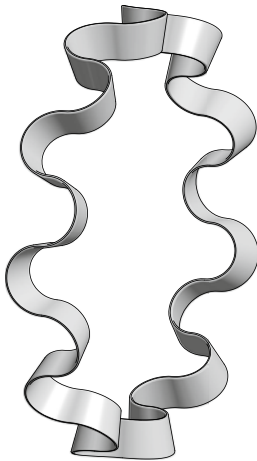

Fig. 12.2.5

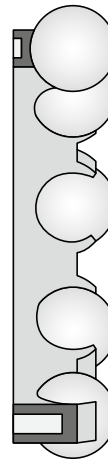

Fig. 12.2.6

Accuracy

Bearings are usually made in normal accuracy level P0 whilst this symbol is not presented. For more exacting locations bearings in higher accuracy level P6 are made.

The limit values of bearing dimension and run accuracy are stated in charts 7.2 to 7.4, and comply with the standard ISO 492.

Axial clearance

Commonly produced bearings feature normal axial clearance that is not identified. Special locations require bearings with reduced C2 and increased axial clearance C3 and C4. Axial clearance values are stated in chart 7.17b.

Misalignment

Bearings form very rigid locations and are extremely sensitive to misalignment of rings caused by assembly inaccuracies. Any misalignment of bearing rings in operation will also increase significantly the noise level and shorten the service life of the bearing.

Minimum load

Bearings with point or line contact must be exposed to certain minimum load in order to ensure their proper operation. This applies also to double row ball bearings working at high revolutions where high acceleration or sudden changes of acting load occur. Under such conditions the inertial forces of balls and cages as well as the friction in the lubricant may have negative impact on the conditions of rolling, which might cause damage to the rolling elements and raceways due to slipping. The required minimum radial load for double row angular contact ball bearings can be estimated by the below relation:

$$F_{rm} = k_r \cdot \left(\frac{vn}{1000} \right)^{\frac{2}{3}} \cdot \left(\frac{d_m}{100} \right)^2$$

F_{rm} is minimum radial load [kN]

k_r is coefficient of minimum radial load

..... 0.06 for bearings of series 32

..... 0.07 for bearings of series 33

v oil viscosity at service temperature [mm²/s]

n revolutions [min⁻¹]

d_m mean diameter of bearing, i.e. 0.5 (d + D), [mm]



At start-up in low temperatures, or in use of grease with high viscosity even higher minimum load may be necessary. The weight of components captured by bearing, along with external forces is often higher than the minimum load required. If this is not the case, an additional radial load must act on double row angular contact ball bearing.



Equivalent radial dynamic load

$$P_r = F_r + 0.73F_a \quad \text{for } F_a / F_r \leq 0.86$$

$$P_r = 0.62F_r + 1.17F_a \quad \text{for } F_a / F_r > 0.86$$

Equivalent radial static load

$$P_{or} = F_r + 0.63F_a$$

Double row angular contact ball bearings d = 10 to 110 mm

d = 10 to 70 mm

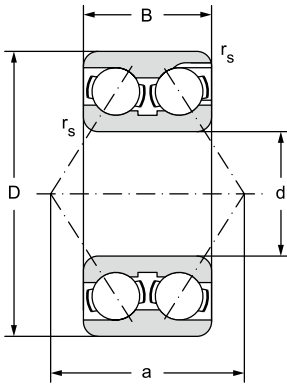

12.2.3

Main dimensions					Basic load rating		Fatigue load limit
d	D	B	r _s	a	dynamic (C _r)	static (C _{0r})	P _u
mm					kN		kN
10	30	14,0	0,6	20,0	9,253	5,840	0,265
	30	14,3	0,6	20,0	9,253	5,840	0,265
12	32	15,9	0,6	22,0	11,050	7,080	0,322
15	35	15,9	0,6	23,0	10,381	7,500	0,341
	42	19,0	1,0	27,0	17,369	11,900	0,541
17	40	17,5	0,6	27,0	14,418	10,600	0,482
	47	22,2	1,0	31,0	23,649	16,200	0,736
20	47	20,6	1,0	31,0	19,905	15,000	0,682
	52	22,2	1,1	34,0	23,656	18,500	0,841
25	52	20,6	1,0	35,0	21,539	18,100	0,823
	62	25,4	1,1	40,0	32,881	26,600	1,209
30	62	23,8	1,0	41,0	30,998	27,100	1,232
	72	30,2	1,1	47,0	43,688	36,200	1,645
35	72	27,0	1,1	47,0	42,125	37,600	1,709
	80	34,9	1,5	54,0	56,219	47,300	2,150
40	80	30,2	1,1	52,0	48,186	43,800	1,991
	90	36,5	1,5	58,0	59,431	59,600	2,709
45	85	30,2	1,1	56,0	51,994	51,100	2,323
	100	39,7	1,5	64,0	82,479	73,600	3,345
50	90	30,2	1,1	59,0	59,553	58,400	2,655
	110	44,4	2,0	73,0	99,898	96,200	4,373
55	100	33,3	1,5	64,0	74,481	66,800	3,036
	120	49,2	2,0	80,0	110,379	108,000	4,909
60	110	36,5	1,5	71,0	82,491	85,800	3,900
	130	54,0	2,1	86,0	128,709	128,000	5,818
65	120	38,1	1,5	76,0	90,746	94,400	4,291
	140	58,7	2,1	94,0	146,328	147,000	6,600
70	125	39,7	1,5	81,0	87,349	98,100	4,459

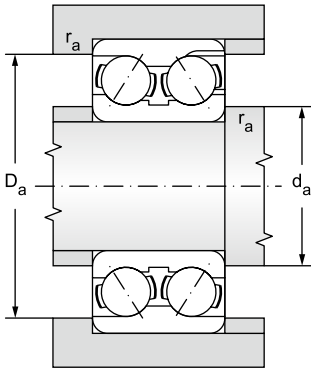

** Bearings in the new standard NEW FORCE

Limiting speed for lubrication with		Bearing designation	Abutment and Fillet Dimensions				Weight
Grease	Oil		d	d _a	D _a	r _a	
min ⁻¹				min	max	max	kg
16 000	19 000	3200X**	10	14	25	0,6	0,05
16 000	19 000	3200**	10	14	25	0,6	0,05
14 000	17 000	3201**	12	16	27	0,6	0,05
13 000	16 000	3202**	15	19	30	0,6	0,07
10 600	12 600	3302**	15	21	26	1	0,13
11 000	13 000	3203**	17	21	35	0,6	0,1
9 400	11 000	3303**	17	23	41	1	0,19
9 400	11 000	3204**	20	25	42	1	0,17
8 400	10 000	3304**	20	27	45	1	0,23
8 400	10 000	3205**	25	30	46	1	0,19
7 100	8 400	3305**	25	32	55	1	0,37
7 100	8 400	3206**	30	35	56	1	0,31
6 000	7 100	3306**	30	37	65	1	0,58
6 000	7 100	3207**	35	41	65	1	0,48
5 300	6 300	3307**	35	44	71	1,5	0,78
5 300	6 300	3208**	40	46	73	1	0,65
4 700	5 600	3308**	40	49	81	1,5	1,05
5 000	6 000	3209**	45	51	78	1	0,7
4 200	5 000	3309**	45	54	91	1,5	1,41
4 500	5 300	3210**	50	56	83	1	0,74
3 800	4 500	3310**	50	60	100	2	1,9
4 200	5 000	3211**	55	62	91	1,5	1,05
3 300	4 000	3311**	55	65	110	2	2,48
3 800	4 500	3212**	60	67	101	1,5	1,36
3 200	3 800	3312**	60	72	118	2	3,17
3 500	4 200	3213**	65	72	111	1,5	1,76
3 000	3 500	3313**	65	77	128	2	4,01
3 200	3 800	3214**	70	77	116	1,5	1,93

Double row angular contact ball bearings

d = 75 to 110 mm

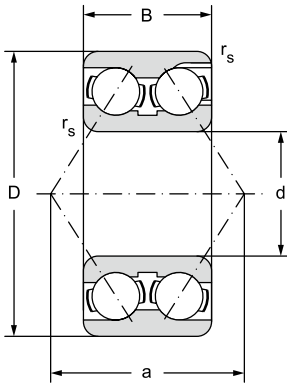

12.2.3

Main dimensions					Basic load rating		Fatigue load limit
d	D	B	r _s	a	dynamic (C _r)	static (C _{0r})	P _u
mm					kN		kN
75	130	41,3	1,5	84,0	96,151	110,000	4,939
80	140	44,4	2,0	82,0	95,000	106,000	3,900
	170	68,3	2,1	101,0	156,000	182,000	6,000
85	150	49,2	2,0	88,0	110,000	124,000	4,400
	180	73,0	3,0	107,0	176,000	195,000	6,550
90	160	52,4	2,0	94,0	120,000	130,000	4,550
	190	73,0	3,0	112,0	180,000	195,000	6,400
95	170	55,6	2,1	101,0	146,000	159,000	5,400
	200	77,8	3,0	118,0	216,000	225,000	7,500
100	180	60,3	2,1	107,0	166,000	178,000	6,000
	215	82,6	3,0	127,0	255,000	255,000	8,650
110	200	69,8	2,1	119,0	212,000	212,000	7,200
	240	92,1	3,0	142,0	305,000	291,000	9,800

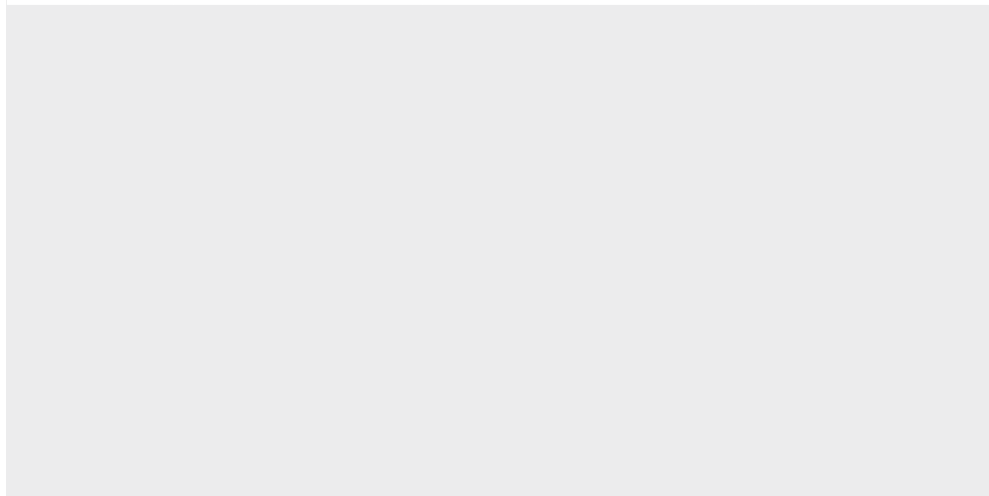

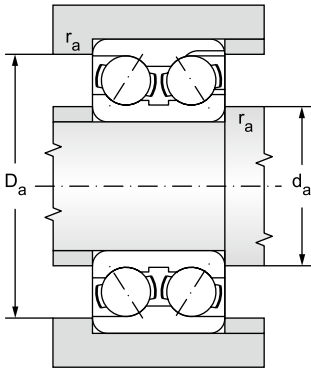

** Bearings in the new standard NEW FORCE

Limiting speed for lubrication with		Bearing designation	Abutment and Fillet Dimensions				Weight
Grease	Oil		d	d _a	D _a	r _a	
min ⁻¹				min	max	max	kg
3 200	3 800	3215**	75	82	121	1,5	2,08
2 800	3 800	3216	80	91	129	2	2,65
2 400	3 400	3316		92	158	2	6,8
2 600	3 600	3217	85	96	139	2	3,4
2 200	3 200	3317		99	166	2,5	8,3
2 400	3 400	3218	90	101	149	2	4,15
2 000	3 000	3318		104	176	2,5	9,25
2 200	3 200	3219	95	107	158	2	5
1 900	2 800	3319		109	186	2,5	11
2 000	3 000	3220	100	112	168	2	6,1
1 800	2 600	3320		114	201	2,5	13,5
1 900	2 800	3222	110	122	188	2	8,8
1 700	2 400	3322		124	226	2,5	19

Four-point contact bearings d = 15 to 200 mm

d = 15 to 75 mm

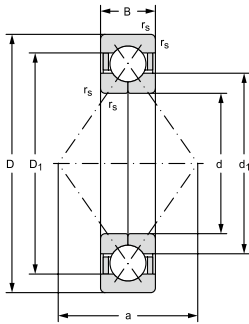

12.2.4

Main dimensions					Basic load rating		Fatigue load limit	Limiting speed for lubrication with		Weight
d	D	B	r _{fs} min	a	dynamic	static	P _u	Grease	Oil	
					C _r	C _{or}				
mm					kN		kN	m ⁻¹		kg
15	35	11	0,6	18	12,7	8,3	0,36	15000	20000	0,062
17	40	12	0,6	20	15,9	10,6	0,45	14000	19000	0,082
	47	14	1	22	23,4	15	0,64	12000	17000	0,14
20	52	15	1,1	25	29,6	20	0,85	10000	15000	0,18
25	52	15	1	25	25,1	20	0,83	9500	14000	0,16
	62	17	1,1	30	39,1	28	1,18	9000	14000	0,29
30	62	16	1	32	35,1	28,5	1,2	8500	12000	0,24
	72	19	1,1	36	49,4	39	1,63	7500	10000	0,42
35	72	17	1,1	37	46,2	39	1,63	7500	10000	0,36
	80	21	1,5	40	59,2	46,5	1,96	7000	9500	0,57
40	80	18	1,1	42	52,7	45	1,9	6700	9000	0,45
	90	23	1,5	46	71,5	58,5	2,45	6300	8500	0,78
45	85	19	1,1	46	58,5	51	2,16	6300	8500	0,52
	100	25	1,5	51	93,6	76,5	3,25	5600	7500	1,05
50	90	20	1,1	49	61,8	56	2,4	5600	7500	0,59
	110	27	2	56	111	91,5	3,9	5000	6700	1,35
	110	27	2	56	111	91,5	3,9	5000	6700	1,35
55	100	21	1,5	54	79,3	76,5	3,2	5300	7000	0,77
	120	29	2	61	127	108	4,55	4500	6000	1,75
60	110	22	1,5	60	92,3	86,5	3,65	4800	6300	0,99
	130	31	2,1	67	146	125	5,3	4300	5600	2,15
65	120	23	1,5	65	104	104	4,4	4300	5600	1,2
	140	33	2,1	72	165	146	6,1	4000	5300	2,7
70	125	24	1,5	68	114	114	4,8	4300	5600	1,32
	150	35	2,1	77	186	166	6,7	3600	4800	3,15
75	130	25	1,5	72	117	122	5,2	4000	5300	1,45
	160	37	2,1	82	199	186	7,35	3400	4500	3,9

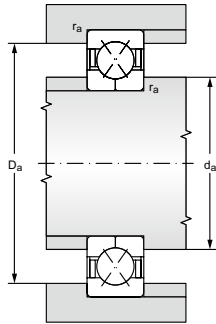

Bearing designation		Dimensions			Dimensions of grooves			Abutment and Fillet Dimensions		
Bearing with safety grooves	Bearing without safety grooves	d	d _i	D _i	b	h	r _o	d _a min	D _a max	r _a max
mm										
QJ202N2MA	-	15	22	28,1	3	2,2	0,5	19,2	30,8	0,6
QJ203N2MA	-	17	23,5	32,5	3,5	2,5	0,5	21,2	35,8	0,6
QJ303N2MA	-	27,7	36,3	45	4,5	3,5	0,5	22,6	41,4	1
QJ304N2MA	QJ304MA	20	27,5	40,8	4,5	3,5	0,5	27	45	1
QJ205N2MA	QJ205MA	25	31,5	43	4,5	3	0,5	30,6	46,4	1
QJ305N2MA	QJ305MA		34	49	4,5	3,5	0,5	32	55	1
QJ206N2MA	QJ206MA	30	37,5	50,8	4,5	3,5	0,5	35,6	56,4	1
QJ306N2MA	QJ306MA		40,5	58,2	4,5	3,5	0,5	37	65	1
QJ207N2MA	-	35	44	59	4,5	3,5	0,5	42	65	1
QJ307N2MA	QJ307MA		46,2	64,3	5,5	4	0,5	44	71	1,5
QJ208N2MA	QJ208MA	40	49,5	66	5,5	4	0,5	47	73	1
QJ308N2MA	QJ308MA		52	72,5	5,5	4	0,5	49	81	1,5
-	QJ209MA	45	54,5	72	-	-	-	52	78	1
QJ309N2MA	QJ309MA		58	81,2	6,5	5	0,5	54	91	1,5
-	QJ210MA	50	59,5	76,5	5,5	4	0,5	57	83	1
-	QJ310MA		65	90	-	-	-	61	99	2
-	QJ310PHAS		65	90	-	-	-	61	99	2
QJ211N2MA	QJ211MA	55	66	84,7	6,5	5	0,5	64	91	1,5
QJ311N2MA	QJ311MA		70,5	97,8	6,5	8,1	0,5	66	109	2
QJ212N2MA	QJ212MA	60	72	93	6,5	5	0,5	69	101	1,5
QJ312N2MA	QJ312MA		77	106	6,5	8,1	0,5	72	118	2
QJ213N2MA	QJ213MA	65	78,5	101	6,5	6,5	0,5	74	111	1,5
-	QJ313MA		82,5	115	-	-	-	77	128	2
QJ214N2MA	QJ214MA	70	83,5	106	6,5	6,5	0,5	79	116	1,5
QJ314N2MA	QJ314MA		89	123	8,5	10,1	2	82	138	2
QJ215N2MA	QJ215MA	75	88,5	112	6,5	6,5	0,5	84	121	1,5
QJ315N2MA	-		104	131	8,5	10,1	2	87	148	2

Four-point contact bearings

d = 80 to 200 mm

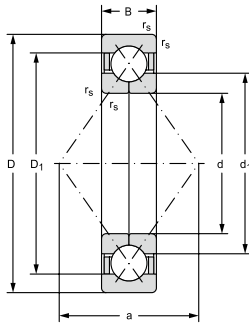

12.2.4

Main dimensions					Basic load rating		Fatigue load limit	Limiting speed for lubrication with		Weight
d	D	B	r _{fs} min	a	dynamic	static	P _u	Grease	Oil	
					C _r	C _{or}				
mm					kN		kN	m ⁻¹		kg
80	140	26	2	77	138	146	5,85	3600	4800	1,85
	170	39	2,1	88	216	208	8	3200	4300	4,6
85	150	28	2	83	148	160	6,2	3400	4500	2,25
	180	41	3	93	234	236	8,65	3000	4000	5,45
90	160	30	2	88	174	186	6,95	3200	4300	2,75
	190	43	3	98	265	285	10,2	2800	3800	6,45
95	170	32	2,1	93	199	212	7,8	3000	4000	3,35
	200	45	3	103	286	315	11	2600	3600	7,45
100	180	34	2,1	98	225	240	8,65	2800	3800	4,05
	215	47	3	110	307	340	11,6	2400	3400	9,3
110	200	38	2,1	109	265	305	10,4	2400	3400	5,6
	240	50	3	123	390	475	15	2000	3000	12,5
120	215	40	2,1	117	286	340	11,2	2200	3200	6,95
	260	55	3	133	390	490	15	1900	2800	16
130	230	40	3	126	296	365	11,6	1900	2800	7,75
	280	58	4	144	423	560	16,6	1800	2600	19,5
140	250	42	3	137	325	440	13,2	1800	2600	9,85
	300	62	4	154	468	640	18,6	1800	2600	24
150	270	45	3	147	338	465	15,3	1700	2400	12,5
	320	65	4	165	494	710	19,6	1600	2200	29
160	290	48	3	158	390	570	17,6	1600	2200	15,5
	340	68	4	175	540	815	21,6	1500	2000	34,5
170	310	52	4	168	397	600	18,3	1600	2200	19,5
	360	72	4	186	618	965	25	1400	1900	41,5
180	320	52	4	175	436	680	19	1500	2000	20,5
	380	75	4	196	637	1020	26	1300	1800	47,5
190	400	78	5	207	690	1100	28,5	1200	1600	49
200	360	58	4	196	507	850	23,2	1300	1800	28,5

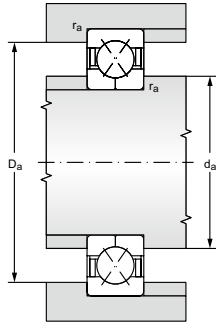

Bearing designation		Dimensions			Dimensions of grooves			Abutment and Fillet Dimensions		
Bearing with safety grooves	Bearing without safety grooves	d	d _i	D _i	b	h	r _o	d _a min	D _a max	r _a max
mm										
QJ216N2MA	QJ216MA	80	95,3	120	6,5	8,1	1	91	129	2
QJ316N2MA	-		111	139	8,5	10,1	2	92	158	2
QJ217N2MA	QJ217MA	85	100	128	6,5	8,1	1	96	139	2
QJ317N2MA	-		117	148	10,5	11,7	2	99	166	2,5
QJ218N2MA	-	90	114	136	6,5	8,1	1	101	149	2
QJ318N2MA	-		124	156	10,5	11,7	2	104	176	2,5
QJ219N2MA	-	95	120	145	6,5	8,1	1	107	158	2
QJ319N2MA	-		131	165	10,5	11,7	2	109	186	2,5
QJ220N2MA	-	100	127	153	8,5	10,1	2	112	168	2
QJ320N2MA	-		139	176	10,5	11,7	2	114	201	2,5
QJ222N2MA	-	110	141	169	8,5	10,1	2	122	188	2
QJ322N2MA	-		154	196	10,5	11,7	2	124	226	2,5
QJ224N2MA	-	120	152	183	10,5	11,7	2	132	203	2
QJ324N2MA	-		169	211	10,5	11,7	2	134	246	2,5
QJ226N2MA	-	130	165	195	10,5	11,7	2	144	216	2,5
QJ326N2MA	-		182	227	10,5	12,7	2	147	263	3
QJ228N2MA	-	140	179	211	10,5	11,7	2	154	236	2,5
QJ328N2MA	-		196	244	10,5	12,7	2	157	283	3
QJ230N2MA	-	150	194	226	10,5	11,7	2	164	256	2,5
QJ330N2MA	-		211	259	10,5	12,7	2	167	303	3
QJ232N2MA	-	160	206	243	10,5	12,7	2	174	276	2,5
QJ332N2MA	-		224	276	10,5	12,7	2	177	323	3
QJ234N2MA	-	170	221	258	10,5	12,7	2	187	293	3
QJ334N2MA	-		237	293	10,5	12,7	2	187	343	3
QJ236N2MA	-	180	231	269	10,5	12,7	2	197	303	3
QJ336N2MA	-		252	309	10,5	12,7	2	197	363	3
QJ338N2MA	-	190	263	326	10,5	12,7	2	210	380	4
QJ240N2MA	-	200	258	302	10,5	12,7	2	217	363	3





12.3 DOUBLE ROW SELF ALIGNING BALL BEARINGS



Design

Bearings are designed with two rows of balls and round raceway on the outer ring, which enables certain tilting of the inner ring towards the outer ring around the bearing centre without impeding bearing function (fig. 12.3.1). Bearings are made with a cylindrical (a) or tapered (b) bore and are non-detachable. The self-aligning ability, while maintaining functionality, determines the bearing application in cases, where certain misalignment of bores in the bearing hubs or deflection and oscillation of the shaft are expected. Due to the small contact angle and imperfect adherence of the balls to the raceways, they are unsuitable for capturing greater axial forces.

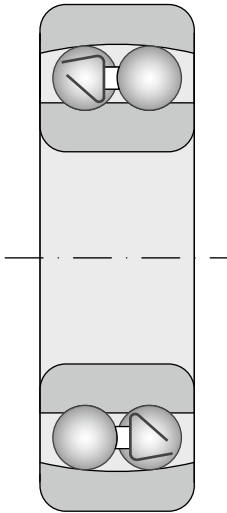

Fig. 12.3.1a

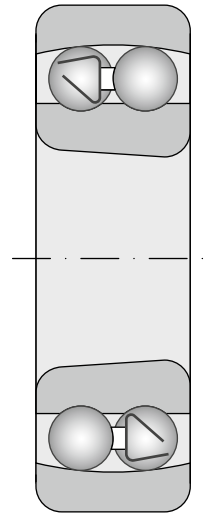

Fig. 12.3.1b

Due to the small adherence of balls on the outer ring spherical surface, self-aligning ball bearings elicit little friction in comparison to other types of bearings and the heat generated is thus also less. The ZKL product line includes only standard uncovered bearings.

Standard design

ZKL double row self-aligning ball bearings, manufactured to NEW FORCE standards, are designated as ** in the tables. Standard self-aligning ball bearings are designed with a cylindrical bore. They are also alternatively



designed with a tapered bore [with a 1:12 taper ratio].

Certain series 12 and 13 bearings contain overlapping balls even in the basic non-tilted ring position of the face of both rings. The size of the overlap is specified in the catalogue tables.

Accessories

Adapter sleeves are a basic accessory to self-aligning ball bearings. They serve to fasten bearings with a tapered bore onto the cylindrical shaft. Adapter sleeves are described in the chapter "Bearing accessories." The assignment of adapter sleeves is specified in the catalogue tables.

Main dimensions

The main dimensions of bearings are consistent with standard ISO 15 and are listed for individual bearings in the tables of the publication.

Precision

Bearings are currently produced at a normal degree of precision P0, which is not marked. Bearings for more demanding loadings and higher degree of precision P6 are also supplied.

The dimensional and operational precision tolerances are listed in tables 7.2 to 7.4b and are consistent with standard ISO 492.

Self-alignment ability

Table 12.3.1

Bearing type	Permissible tilt α
d<10mm; series 126; series 13; series 23	$\pm 3^\circ$
series 12; series 22	$\pm 2^\circ 30'$

Self-aligning ball bearings enable, within certain limits, the mutual alignment of rings without negatively affecting the bearing function (fig. 4.9a)

Permissible alignment values of bearing rings, while maintaining functionality, are listed in table 12.3.1.

Internal clearance

Commonly manufactured bearings have a normal internal radial clearance, which is not labelled. Bearings with a reduced clearance C2 or increased radial clearance C3 are supplied for special conditions. The supplier must be consulted for delivery of bearings with C4 and C5 clearance.

Clearance values that conform to standard ISO 5753 are listed in table 7.18. Values apply to bearings prior to installation and without the use of a measuring load.

Table 12.3.2

Bearings with steel sheet or brass cage	Bearings with massive brass or steel cage
d < 10 mm; series 126	-
1200 to 1222	1224 až 1230
2200 to 2222	-
1300 to 1322	1324
2304 to 2320 ¹⁾	2322

¹⁾ Bearing 2305 is manufactured with a massive plastic cage with filler (TNGN)



Cages

Bearings, in their standard design, general have cages as listed in table 12.3.2 (the symbol characterizing the material and cage design is usually not specified).

Note:

TNGN cages can work in bearings for normal operating conditions, i.e. up to +120 °C.

Axial loading capacity

The ability of self aligning ball bearings, installed on adapter sleeves on a shaft without shoulder, to carry axial loads depends on the friction between the sleeve and the shaft. The permissible axial loading capacity can be roughly determined by the relationship

$$F_{ap} = 0.003 \cdot B \cdot d$$

F_{ap} maximum permissible axial loading capacity [kN]

B bearing width [mm]

d bearing bore diameter [mm]

Minimal load

A certain minimal load must act on all single-point contact or line contact bearings to ensure their satisfactory operation. This also applies for self aligning ball bearings, especially when they must operate at high speeds, with high acceleration, or when the direction of the acting load suddenly changes. Under such conditions, the inertial forces of balls, cages, and friction in the lubricant can have a negative effect on the rolling conditions and can cause harmful slippage between the balls and the raceways.

The requisite minimal load for self aligning ball bearings can be estimated using the relationship

$$P_m = 0.01 \cdot C_o$$



P_m minimal equivalent load [kN]

C_0 static load capacity [kN]

A higher minimum load may be required when starting under low temperatures or when using a high viscosity lubricant. The weight of components associated with the bearing together with external forces is often greater than the requisite minimal load. If not, then an auxiliary axial load may act on the bearing, which is elicited e.g. by increased tension of a belt, etc.

Equivalent dynamic radial load of bearing

$$P_r = F_r + Y_1 F_a \quad \text{for } F_a/F_r \leq e \quad [\text{kN}]$$

$$P_r = 0.65F_r + Y_2 F_a \quad \text{for } F_a/F_r > e \quad [\text{kN}]$$

The values of coefficients e , Y_1 and Y_2 for individual bearings are listed in the tables of the publication.

Equivalent static radial load of bearing

$$P_{or} = F_r + Y_0 F_a \quad [\text{kN}]$$

The values of coefficients Y_0 for individual bearings are listed in the tables of the publication.

Additional markings

Markings of standard bearings and of bearings with a tapered bore are listed in the tables of the publication. Divergence from the standard design is marked by the additional characters provided below:

C2Radial internal clearance less than Normal

C3Radial internal clearance greater than Normal

KTapered bore with 1:12 taper ratio

TNGN.Injected open cage from fibreglass reinforced polyamide 6.6, ball-guided

Installation of bearings with tapered bore

Bearings with a tapered bore have a taper size of 1:12. Bearings with a tapered bore are fastened on a cylindrical shaft using adapter sleeves. Sleeve designations belonging to individual bearings are listed in the tables of the publication.

Self-aligning ball bearings with tapered bore are always installed with an overlap on the conical journal or on the adapter or withdrawal sleeve. A decrease in the internal radial bearing clearance or in the axial shift of the internal ring on the conical journal can be used to measure the overlap size. Suitable methods for checking correct installation of self-aligning ball bearings with a tapered bore are provided below:



- Measuring the decrease of clearance.
- Measuring the lock nut tightening angle.
- Measuring the axial displacement.

Measuring the decrease of clearance

When installing self-aligning ball bearings in standard design with a relatively small Normal radial internal clearance, it generally suffices to check the decrease in clearance during installation by turning and tilting the outer bearing ring. If the bearing is properly installed, then the outer ring can easily be turned; however, you must feel slight resistance when tilting the bearing outer ring. In such a case, the bearing is installed with a correct overlap.

In certain cases, however, the resulting internal clearance for the give application may be too small. Consequently, a bearing with an internal radial clearance of C3 should be used.

Measuring the torque of lock nuts

Measuring the tightening angle of the lock nut presents an easy method of installing self-aligning ball bearings with a tapered bore. Recommended tightening angles and lock nut torques are specified in table 12.3.3.

The bearing must be pushed onto the conical journal or sleeve prior to final nut tightening so that it touches the contact surfaces along its entire perimeter (i.e. so it cannot be turned). By tightening the nut by the given angle α , move the bearing on the tapered surface the correct distance. The resulting clearance in the bearing must be checked by turning and tilting the outer bearing ring.

Then unscrew the nut and carefully install the lock washer and re-tighten the nut. Secure the nut by bending the lock washer tab so the tab fits into the slot on the lock nut.

Measuring axial displacement

Installation of bearings with a tapered bore can also be based on measuring the axial displacement of the inner ring on the tapered contact surface. The recommended values of requisite axial displacement "s" are listed in the following table.

Table 12.3.3

Bore diameter	Tightening angle	Axial displacement
d	α	s
mm	degrees	mm
20	80	0,22
25	55	0,22
30	55	0,22
35	70	0,3
40	70	0,3
45	80	0,35
50	80	0,35
55	75	0,4
60	75	0,4
65	80	0,4
70	80	0,4
75	85	0,45
80	85	0,45
85	110	0,6
90	110	0,6
95	110	0,6
100	110	0,6
110	125	0,7
120	125	0,7

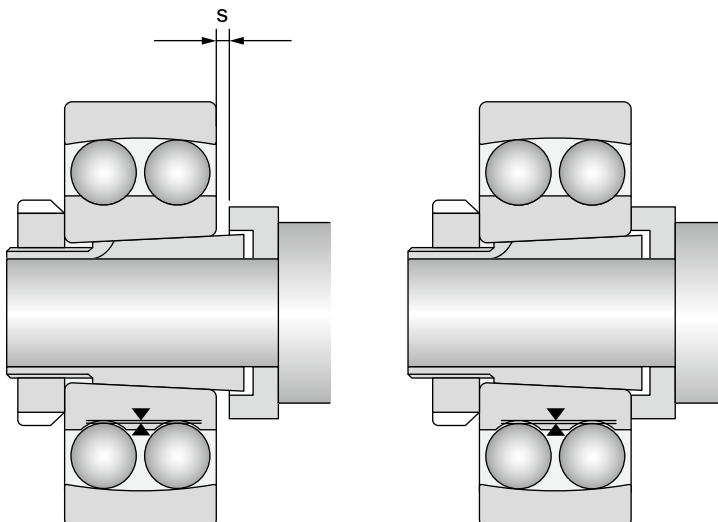
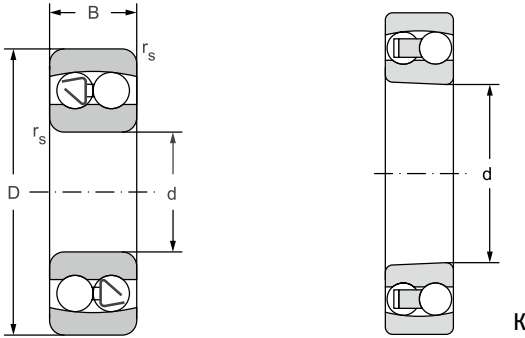

Fig. 12.3.2



Double row self aligning ball bearings d = 10 to 150 mm

d = 10 to 50 mm



12.3.1

Main dimensions					Basic load rating		Fatigue load limit	Limiting speed for lubrication with		Bearing designation	
d	D	B	B ₁ ¹⁾	r _s	dynamic	static				with cylindrical bore	with tapered bore
mm					C _r	C _{or}	P _u	Grease	Oil		
					kN		kN	min ⁻¹			
10	30	14	-	0,6	7,28	1,58	0,07	25 000	30 000	2200	-
12	32	10	-	0,6	5,59	1,26	0,06	24 000	28 000	1201	-
15	35	11	-	0,6	7,41	1,74	0,08	21 000	25 000	1202	-
	35	14	-	0,6	7,61	1,81	0,08	21 000	25 000	2202	-
17	40	12	-	0,6	8,14	2,03	0,09	17 000	20 000	1203**	1203K**
20	47	14	-	1,0	10,20	2,66	0,12	14 000	17 000	1204**	1204K**
25	52	15	-	1,0	12,50	3,35	0,15	12 600	15 000	1205**	1205K**
	52	18	-	1,0	12,90	3,48	0,16	12 600	15 000	2205**	2205K**
	62	17	-	1,1	18,50	5,01	0,23	10 000	13 000	1305**	1305K**
	62	24	-	1,1	25,20	6,56	0,30	10 000	12 000	2305TNGN**	2305KTNGN**
30	62	16	-	1,0	16,70	4,73	0,22	11 000	13 000	1206**	1206K**
	62	20	-	1,0	15,80	4,55	0,21	11 000	13 000	2206**	2206K**
	72	19	-	1,1	22,00	6,31	0,29	9 400	11 000	1306**	1306K**
	72	27	-	1,1	32,30	8,74	0,40	8 400	10 000	2306**	2306K**
35	72	17	-	1,1	16,30	5,11	0,23	9 400	11 000	1207**	1207K**
	72	23	-	1,1	22,40	6,68	0,30	9 400	11 000	2207**	2207K**
	80	31	-	1,5	39,50	11,20	0,51	7 200	8 800	2307	2307K
40	80	18	-	1,1	19,90	6,56	0,30	7 900	9 400	1208**	1208K**
	90	23	-	1,5	29,90	9,81	0,45	7 100	8 400	1308**	1308K**
	90	33	-	1,5	46,10	13,30	0,60	6 700	7 900	2308**	2308K**
45	85	19	-	1,1	22,60	7,36	0,33	7 500	8 900	1209**	1209K**
	85	23	-	1,1	24,00	8,10	0,37	7 500	8 900	2209**	2209K**
	100	25	-	1,5	39,10	12,80	0,58	6 300	7 500	1309**	1309K**
	100	36	-	1,5	55,40	16,50	0,75	6 000	7 100	2309**	2309K**
50	90	20	-	1,1	23,40	8,10	0,37	7 100	8 400	1210**	1210K**
	90	23	-	1,1	24,00	8,41	0,38	7 100	8 400	2210**	2210K**
	110	27	-	2,0	44,60	14,10	0,64	5 600	6 700	1310**	1310K**
	110	40	-	2,0	64,50	19,80	0,90	5 300	6 300	2310	2310K

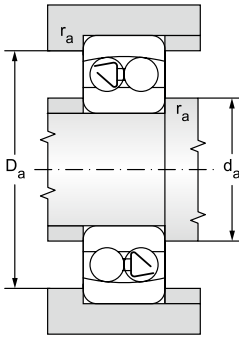

** Bearings in the new standard NEW FORCE
¹⁾ The dimension B1 indicates the bearing width measured over balls if they protrude from the bearing side faces

Abutment and Fillet Dimensions				Weight		Respective adapter sleeve	Coefficients			
d	d _s min	D _s max	r _a max	-	K		e	Y ₁	Y ₂	Y ₀
mm				kg						
10	14	26	0,6	0,0	-	-	0,65	1,0	1,5	1
12	16	18	0,6	0,0	-	-	0,34	1,9	2,9	2,0
15	19	31	0,6	0,0	-	-	0,33	1,9	2,9	2,0
	19	31	0,6	0,1	-	-	0,49	1,3	2,0	1,3
17	21	36	0,6	0,1	0,1	H203	0,31	2,1	3,2	2,2
20	25	42	1,0	0,1	0,1	H204	0,27	2,3	3,6	2,4
25	30	47	1,0	0,1	0,1	H205	0,27	2,3	3,6	2,4
	30	47	1,0	0,2	0,2	H305	0,43	1,5	2,3	1,5
	32	55	1,0	0,3	0,3	H305	0,28	2,3	3,5	2,4
	31	55	1,0	0,3	0,3	H2305	0,47	1,3	2,1	1,4
30	35	57	1,0	0,2	0,2	H206	0,25	2,6	4,0	2,7
	35	57	1,0	0,3	0,3	H306	0,40	1,6	2,5	1,7
	36	65	1,0	0,4	0,4	H306	0,26	2,5	3,8	2,6
	36	65	1,0	0,5	0,5	H2306	0,44	1,4	2,2	1,5
35	42	65	1,0	0,3	0,3	H207	0,23	2,7	4,2	2,9
	42	65	1,0	0,4	0,4	H307	0,37	1,7	2,6	1,8
	44	71	1,5	0,7	0,7	H2307	0,46	1,4	2,1	1,4
40	47	73	1,0	0,4	0,4	H208	0,22	2,9	4,4	3,0
	47	81	1,5	0,7	0,7	H308	0,24	2,6	4,1	2,7
	47	81	1,5	0,9	0,9	H2308	0,43	1,5	2,3	1,5
45	52	78	1,0	0,5	0,5	H209	0,21	3,0	4,6	3,1
	52	78	1,0	0,6	0,5	H309	0,31	2,1	3,2	2,2
	52	91	1,5	1,0	0,9	H309	0,25	2,5	3,9	2,7
	52	91	1,5	1,2	1,2	H2309	0,42	1,5	2,3	1,6
50	57	83	1,0	0,5	0,5	H210	0,20	3,1	4,9	3,3
	57	83	1,0	0,6	0,6	H310	0,29	2,2	3,4	2,3
	60	100	2,0	1,2	1,2	H310	0,24	2,7	4,1	2,8
	61	99	2,0	1,7	1,7	H2310	0,43	1,5	2,3	1,6

Double row self aligning ball bearings

d = 55 to 100 mm

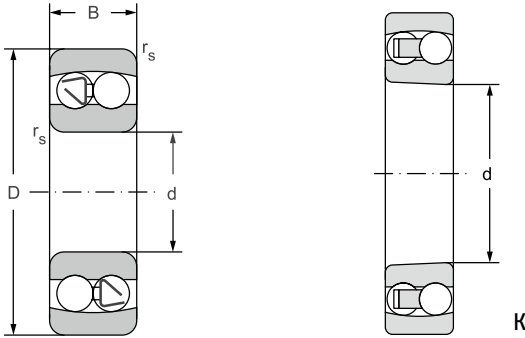

12.3.1

Main dimensions					Basic load rating		Fatigue load limit	Limiting speed for lubrication with		Bearing designation	
d	D	B	B ₁ ¹⁾	r _s	dynamic	static				with cylindrical bore	with tapered bore
mm					C _r	C _{or}	P _u	Grease	Oil		
					kN		kN	min ⁻¹			
55	100	21	-	1,5	27,60	10,00	0,45	6 300	7 500	1211**	1211K**
	100	25	-	1,5	27,30	10,00	0,45	6 300	7 500	2211**	2211K**
	120	29	-	2,0	51,50	18,20	0,82	5 300	6 300	1311	1311K
60	110	22	-	1,5	31,00	11,70	0,53	5 600	6 700	1212**	1212K**
	110	28	-	1,5	35,20	12,60	0,57	5 600	6 700	2212**	2212K**
	130	31	-	2,0	58,80	20,70	0,94	4 700	5 600	1312**	1312K**
65	120	23	-	1,5	31,90	12,30	0,56	5 300	6 300	1213**	1213K**
	120	31	-	1,5	44,90	16,50	0,75	5 300	6 300	2213**	2213K**
	140	48	-	2,1	98,90	32,40	1,47	4 000	4 800	2313**	2313K**
70	125	31	-	1,5	45,20	17,10	0,78	5 000	6 000	2214**	2214K**
	150	35	-	2,0	74,50	27,50	1,20	4 200	5 000	1314M	1314KM
	150	51	-	2,1	112,00	37,60	1,63	3 800	4 500	2314**	2314K**
75	130	25	-	1,5	40,10	15,50	0,70	4 700	5 600	1215**	1215K**
	130	31	-	1,5	45,50	17,80	0,80	4 700	5 600	2215**	2215K**
	160	37	-	2,1	81,70	29,90	1,25	3 800	4 500	1315**	1315K**
	160	55	-	2,1	127,00	43,00	1,80	3 500	4 200	2315**	2315K**
80	140	26	-	2,0	41,00	16,80	0,73	4 500	5 300	1216**	1216K**
	140	33	-	2,0	50,50	20,00	0,87	4 500	5 300	2216**	2216K**
85	150	28	-	2,0	50,60	20,30	0,85	4 000	4 700	1217**	1217K**
	180	41	-	3,0	101,00	37,60	1,48	3 300	4 000	1317**	1317K**
	180	60	-	3,0	144,00	51,10	2,02	3 200	3 800	2317**	2317K**
90	160	30	-	2,0	58,60	23,30	0,95	3 800	4 500	1218**	1218K**
	160	40	-	2,0	72,40	28,70	1,17	3 800	4 500	2218**	2218K**
	190	64	-	3,0	158,00	57,30	2,20	3 000	3 500	2318**	2318K**
95	170	32	-	2,1	65,60	27,10	1,07	3 500	4 200	1219**	1219K**
	170	43	-	2,1	85,70	34,10	1,35	3 500	4 200	2219**	2219K**
	200	45	48	3,0	136,00	51,10	1,91	3 000	3 500	1319**	1319K**
	200	67	-	3,0	170,00	64,30	2,41	2 800	3 300	2319**	2319K**

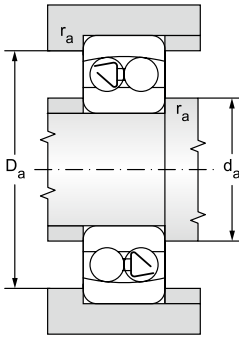

** Bearings in the new standard NEW FORCE
¹⁾ The dimension B_1 indicates the bearing width measured over balls if they protrude from the bearing side faces

Abutment and Fillet Dimensions				Weight		Respective adapter sleeve	Coefficients			
d	d _s min	D _s max	r _s max	-	K		e	Y ₁	Y ₂	Y ₀
mm				kg						
55	62	91	1,5	0,7	0,7	H211	0,20	3,2	5,0	3,4
	62	91	1,5	0,8	0,8	H311	0,28	2,3	3,5	2,4
	66	109	2,0	1,0	1,0	H311	0,23	2,7	4,3	2,9
60	67	101	1,5	0,9	0,9	H212	0,19	3,4	5,3	3,6
	67	101	1,5	1,1	1,1	H312	0,28	2,3	3,5	2,4
	72	118	2,0	2,0	1,9	H312	0,23	2,8	4,3	2,9
65	72	111	1,5	1,2	1,1	H213	0,17	3,7	5,7	3,9
	72	111	1,5	1,5	1,4	H313	0,28	2,2	3,5	2,3
	76	128	2,0	3,3	3,2	H2313	0,38	1,6	2,5	1,7
70	77	116	1,5	1,5	1,5	H314	0,27	2,4	3,7	2,5
	82	138	2,0	3,0	3,0	H314	0,22	2,8	4,4	3,0
	82	138	2,0	3,9	3,8	H2314	0,38	1,7	2,6	1,8
75	82	121	1,5	1,4	1,3	H215	0,18	3,6	5,6	3,8
	82	121	1,5	1,6	1,6	H315	0,25	2,5	3,9	2,6
	86	148	2,0	3,6	3,5	H315	0,22	2,8	4,4	3,0
	86	148	2,0	4,7	4,6	H2315	0,38	1,7	2,6	1,7
80	90	130	2,0	1,7	1,6	H216	0,16	3,9	6,1	4,1
	90	130	2,0	2,0	2,0	H316	0,25	2,5	3,9	2,6
85	95	140	2,0	2,1	2,0	H217	0,17	3,7	5,7	3,9
	98	166	2,5	5,0	4,9	H317	0,22	2,9	4,5	3,0
	98	166	2,5	6,7	6,6	H2317	0,37	1,7	2,7	1,8
90	100	150	2,0	2,5	2,5	H218	0,17	3,8	5,8	3,9
	100	150	2,0	3,2	3,1	H318	0,27	2,4	3,6	2,5
	103	176	2,5	8,0	7,8	H2318	0,38	1,7	2,6	1,8
95	107	158	2,0	3,1	3,1	H219	0,17	3,6	5,7	3,9
	107	158	2,0	4,0	3,9	H319	0,27	2,4	3,6	2,5
	109	186	2,5	6,7	6,6	H319	0,23	2,7	4,3	2,9
	109	186	2,5	9,2	9,0	H2319	0,38	1,7	2,6	1,8

Double row self aligning ball bearings

d = 110 to 150 mm

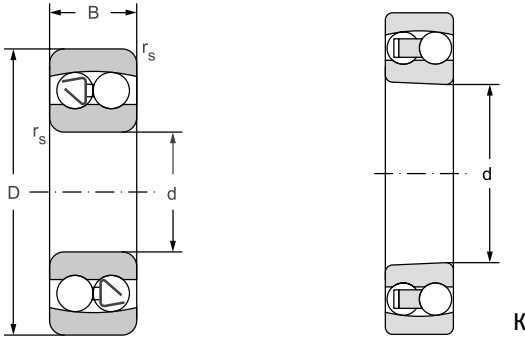

12.3.1

Main dimensions					Basic load rating		Fatigue load limit	Limiting speed for lubrication with		Bearing designation	
d	D	B	B ₁ ¹⁾	r _s	dynamic	static				with cylindrical bore	with tapered bore
mm					C _r	C _{or}	P _u	Grease	Oil		
					kN		kN	min ⁻¹			
100	180	34	-	2,1	71,10	29,30	1,13	3 300	4 000	1220**	1220K**
	180	46	-	2,1	96,90	40,60	1,56	3 300	4 000	2220**	2220K**
	215	47	52	3,0	147,00	58,40	2,12	2 800	3 300	1320**	1320K**
	215	73	-	3,0	198,00	77,90	2,82	2 700	3 200	2320**	2320K**
110	200	38	-	2,1	90,50	38,30	1,40	3 000	3 500	1222**	1222K**
	200	53	-	2,1	124,00	52,10	1,90	3 000	3 500	2222**	2222K**
	240	50	55	3,0	168,00	70,80	2,43	2 700	3 200	1322**	1322K**
	240	80	-	3,0	224,00	94,40	3,24	2 500	3 000	2322**	2322K**
120	215	42	45	2,1	119,00	52,10	1,83	2 800	3 300	1224	-
	260	55	62	3,0	196,00	90,90	3,00	2 500	3 000	1324	-
130	230	46	48	3,0	130,00	59,60	2,02	2 700	3 200	1226**	1226K**
140	250	50	54	3,0	164,00	72,20	2,35	2 500	3 000	1228**	1228K**
150	270	54	56	3,0	176,00	85,80	2,69	2 400	2 800	1230**	1230K**

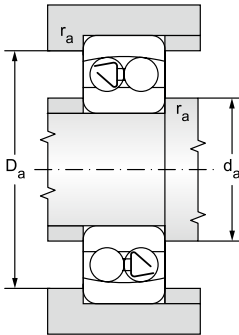

** Bearings in the new standard NEW FORCE
¹⁾ The dimension B_1 indicates the bearing width measured over balls if they protrude from the bearing side faces

Abutment and Fillet Dimensions				Weight		Respective adapter sleeve	Coefficients			
d	d _a min	D _a max	r _a max	-	K		e	Y ₁	Y ₂	Y ₀
mm				kg						
100	112	168	2,0	3,7	3,6	H220	0,17	3,6	5,6	3,8
	112	168	2,0	4,7	4,6	H320	0,27	2,4	3,6	2,5
	113	201	2,5	8,3	8,2	H320	0,24	2,7	4,1	2,8
	113	201	2,5	11,7	11,4	H2320	0,38	1,7	2,6	1,7
110	122	188	2,0	5,2	5,1	H222	0,17	3,6	5,6	3,8
	122	188	2,0	6,8	6,7	H322	0,28	2,3	3,5	2,4
	124	226	2,5	11,8	11,7	H322	0,22	2,8	4,4	3,0
	124	226	2,5	17,3	16,9	H2322	0,37	1,7	2,7	1,8
120	132	203	2,0	6,8	-	-	0,19	3,3	5,1	3,4
	134	246	2,5	15,5	-	-	0,24	2,7	4,1	2,8
130	144	216	2,5	8,3	8,1	-	0,2	3,3	5,0	3,4
140	154	236	2,5	10,9	10,6	-	0,20	3,1	4,8	3,3
150	164	256	2,5	13,8	13,5	-	0,2	3,2	5,0	3,4





12.4 CYLINDRICAL ROLLER BEARINGS

Cylindrical roller bearings are manufactured in many designs, dimensions and sizes. The most common designs are single row cylindrical roller bearings with cage. Single row cylindrical roller bearings are capable of transferring big radial loads and, in some design cases, they are capable of capturing even axial load. Cylindrical roller bearings can operate at high revolutions. The full complement design is capable of transferring big radial loads but at lower rpm.

Majority of design versions is separable which allows easier assembly and disassembly in location. In majority of cases the mutual axial displacement of the outer and inner ring is used when the axial shift of the shaft against the body is aligned inside the bearing without reducing the service life of the bearing. Axial displacement is mostly caused by thermal expansion of the shaft.



Use of cylindrical roller bearings requires good alignment of both rings. Modification of raceways of rings and cylindrical rollers allow only small tilting in case of misalignment without reducing the service life of the bearing. Multirow cylindrical roller bearings have to comply with even more stringent alignment requirements.

ZKL manufactures the following types of cylindrical roller bearings:

- single row cylindrical roller bearings
- double row cylindrical roller bearings
- single row full complement cylindrical roller bearings
- double row full complement cylindrical roller bearings
- multi row cylindrical roller bearings

ZKL further offers special cylindrical roller bearings that are described in more details in chapter Special cylindrical roller bearings:

- single row cylindrical roller bearings and bearing units for railway applications
- electrically insulated cylindrical roller bearings
- single row and multirow bearings for heavy industry
- split cylindrical roller bearings.

Where the space for bearing is limited significantly, cylindrical roller bearing can be used without the inner or outer ring. Rolling elements are guided directly on the shaft or in the body. This location requires that the contact shaft or body surfaces correspond with the structural design of the bearing ring.

SINGLE ROW CYLINDRICAL ROLLER BEARINGS

Design

Single row cylindrical roller bearings with cage are among the mostly used cylindrical roller bearings. These bearings are made in several design versions that are either axially free (do not transfer axial load), or able to capture axial loads in one or both directions.

Single row cylindrical roller bearings are made in dimensional rows same as those of ball bearings, transfer significantly higher radial load than cylindrical roller bearings and are able to work even at extremely high revolution frequencies. Out of the line contact bearings they achieve the highest limit revolution frequencies which are given by minimum slippage of rolling elements.

Ring with guide flanges along with cage and cylindrical rollers can be separated from the other ring which simplifies the assembly and disassembly of the bearing mostly in locations where the inner and outer ring of the bearing has to be pressed at loading conditions.

Bearings in E version have basic dynamic load rating 30% higher in average than bearings in basic version. This is allowed due to the optimised inner design of the bearing.

Basic version

Single row cylindrical roller bearings are made in several design versions that differ in the number and location of guide flanges.

NU design

Inner bearing ring has guide flanges on both sides; the inner ring is without flanges (fig. 12.4.1). NU version bearing is axially free; it allows axial displacement of shaft against body in both directions.

N design

Inner bearing ring has guide flanges on both sides; the outer ring is without flanges (fig. 12.4.2). N version bearing is axially free; it allows axial displacement of shaft against body in both directions.

NJ design

Outer bearing ring has guide flanges on both sides; the inner ring has one guide flange (fig. 12.4.3). NJ design bearing is axially guiding in one direction; in one direction the bearing captures axial load whilst in the other direction it allows axial displacement of shaft against body.

NUP design

Outer bearing ring has guide flanges on both sides; the inner ring has one fixed guide flange and one free flange which consists of free angle ring (fig. 12.4.4). NUP bearing is axially guiding in both directions, it captures axial load in both directions.

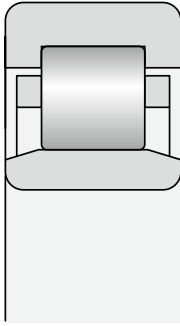

Fig. 12.4.1

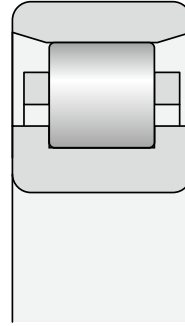

Fig. 12.4.2

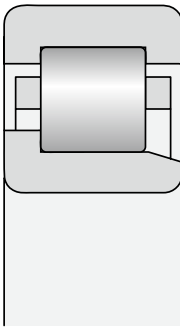

Fig. 12.4.3

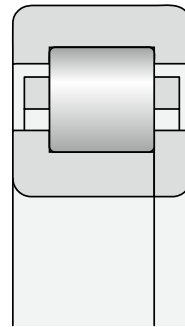

Fig. 12.4.4

Angle rings

NJ and NU version bearings can be used in combinations with HJ angle rings. This enables transfer of double direction axial load in NJ bearings and single direction axial load in NU bearings.

NUP version bearing with shortened inner ring bearing surface should be in case of big radial load interchanged with NJ + HJ bearing. This arrangement has standard width of inner ring that ensures more stable support. Angle rings are made of the same steel as the bearing rings.

The designation and dimensions of angle rings are stated in the table section of the catalogue. Designation of ZKL bearing assembly pair consists of the designation of the bearing and the angle ring as follows: NJ214 + HJ214.

Also associated designation of assemblies that consist of the below examples can be encountered:

$$\text{NJ214} + \text{HJ214} = \text{NH214}$$

$$\text{NU208} + \text{HJ208} = \text{NUJ208}$$

Bearing NJ + HJ (NH)

It is a bearing in NJ version along with angle ring HJ (fig. 12.4.5). NH bearing is axially guiding in both directions; the bearing captures axial load in both directions.

NU + HJ (NUJ) design

It is a bearing in NU version along with angle ring HJ (fig. 12.4.6). NUJ bearing is axially guiding in one direction; in one direction the bearing captures axial load whilst in the other direction it allows axial displacement of shaft against body.

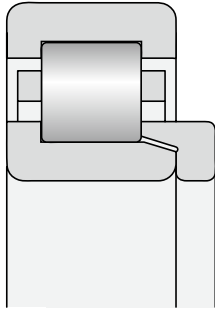

Fig. 12.4.5

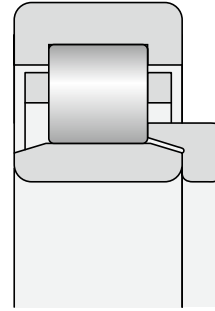

Fig. 12.4.6

Special design

Availability of special design bearings shall be consulted with ZKL.

Bearings without inner or outer ring

Where the space for bearing location is limited, ZKL supplies NU single row cylindrical roller bearings without inner ring marked R NU (fig. 12.4.7), or N single row cylindrical roller bearings without outer ring marked R N (fig. 12.4.8). The raceway is formed directly with hardened and ground surface of shaft or body; these surfaces must comply with stringent requirements, similarly as the raceways of bearing rings. Therefore use of through-hardening steels, cementation steels or steels for high-frequency hardening is recommended in these cases, accordingly with ISO 683-17.

Tolerance of journal dimension is usually „g6“ for normal radial clearance, „f6“ for increased radial clearance and „h5“ for reduced radial clearance. Journal raceway roundness and cylindricity deviations in this case must not exceed those of deviations applicable to the IT3 accuracy level. Maximum surface roughness for this surface should be $R_a = 0.2 \mu\text{m}$ and $R_a = 0.4 \mu\text{m}$ for less exacting locations. Similar tolerances apply to raceway that forms a part of the body.

Basic bearing capacity values C_r , C_{or} , stated in the table section apply to the R NU and R N bearings provided that the hardness on the raceway surface will range within 58 to 64 HRC. With reducing hardness values also the load bearing capacity values C_r drop. For instance, bearings with 48 HRC ring hardness have half the

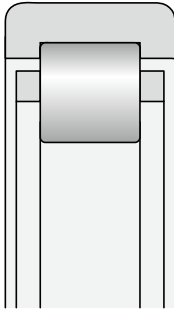

Fig. 12.4.7

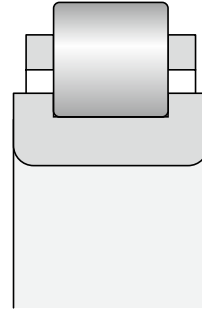

Fig. 12.4.8



value of dynamic load bearing rating. The minimum depth of through hardening of the raceway after abrasion depends on the diameter of rollers and load size, and should be 1 to 3 mm. In big static loading, through hardening to the depth of 0.1 of the roller diameter is recommended. The above stated requirements apply to recommended bearing materials. If other materials are used, the resistance to fatigue damage will reduce.

Bearings with snap ring groove

To ensure simple protection against axial displacement in the location element single row cylindrical roller bearings with a groove for snap ring on outer ring are made. Bearings with snap ring groove have additional designation N (fig. 12.4.9)

Dimensions of the groove for snap ring comply with the standard ISO 464. The standard also states dimensions of relevant snap rings.

Bearings with snap ring grooves

If assembly of outer ring with clearance is required and spinning of outer ring in body has to be prevented, bearing with snap ring grooves on one face of outer ring can be supplies. Bearing provided with one snap ring groove is identified with additional designation N1; bearing with two grooves by 180° is identified with additional designation N2. fig. 12.4.10]

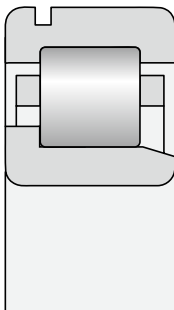

Fig. 12.4.9

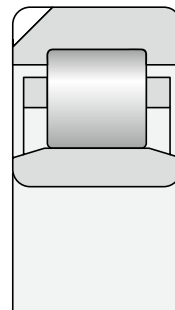

Fig. 12.4.10

General information

Main dimensions

Main dimensions comply with the standard ISO 15 and are stated for individual bearings in the table section of the publication. Main dimensions of angle rings HJ comply with the standard ISO 246 and are also stated in the table section of the catalogue.

Tolerances

Bearings are usually made in normal accuracy level P0 which is not presented. Also bearings in higher accuracy level P6, P5 and P4 are supplied.

The limit values of bearing dimension and run accuracy are stated in tables 7.2 to 7.8, and comply with the standard ISO 492. Tolerances of higher accuracy bearings SP and UP are stated in tables 7.9 to 7.11.

Radial clearance

Commonly produced single row cylindrical roller bearings feature normal axial clearance that is not identified. Special locations require bearings with reduced C2 radial clearance, or with increased radial clearance C3, C4 and C5. Values of radial clearances comply with the standard ISO 5753 and are stated in chart 7.19. The values in the table apply to bearing in non-assembled state and without load.

In some cases bearings with non-standard radial clearance range can be supplied. We recommend that these supplies are discussed with the technical and consultancy services of ZKL.

Misalignment

Mutual misalignment of rings of single row roller bearings is very small. Admissible values of misalignment are stated in table 12.4.1.

Table 12.4.1

Bearing type	Load	
	small ($F_r < 0,1 C_{or}$)	big ($F_r \geq 0,1 C_{or}$)
NU10, NU2, NU3, NU4	2' to 3'	5' to 7'
NU29, NU22, NU23	1' to 3'	3' to 4'
Version NJ, NUP, N ¹⁾	1' to 2'	3' to 4'

¹⁾ lower values of pair of digits apply for bearings of width series 2 and higher

The stated values apply to axially free bearings. At the same time it has to apply that the shaft axis and body axis position do not change. Bigger misalignment than is that stated in the table leads to significant reduction of service life and increased noise level of the bearing. The misalignment values recommended for axially guiding bearings are even lower to avoid unequal loading of guiding flanges which would lead to more significant wear or damage to the flange. Also bearings axially guiding in both direction are very inclinable to

misalignment. In case of bigger misalignment axial clearance in bearing can get defined and rollers gripped by flanges which may cause occurrence of axial stress.

If there is a risk of bigger misalignment angles in roller bearing locations, we recommend that the ZKL technical and consultancy services are contacted.

Sliding axial movement

Axially free (NU, N) and single direction axially guiding (NJ) roller bearings are to certain extent capable of alignment of the shaft axial displacement against the body without reducing the service life of the bearing, Axial displacement is mostly caused by thermal expansion of the shaft. The values of maximum axial shift „s“ of one ring towards the other as shown in the figure 12.4.11 are stated in the table section hereof.

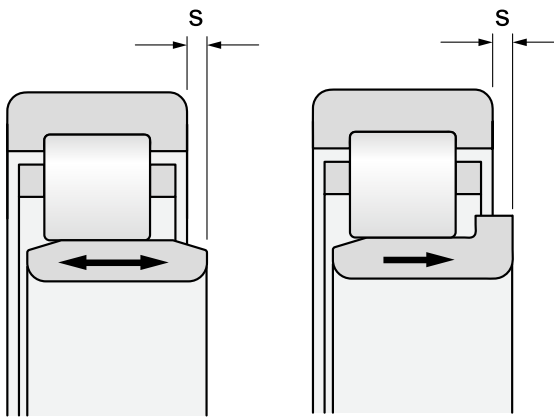

Fig. 12.4.11

Running temperatures

As standard, roller bearings rings are made for use in environment with temperature up to 120°C. Upon request, cylindrical roller bearings with dimension stabilisation for operation at higher temperatures can be supplied.

Cages

Design of cylindrical roller bearing cages:

- Cage pressed from steel plate, guided on rolling elements, additional designation J (is not presented)
- Two-piece massive steel cage guided on rolling elements, additional designation F
- Two-piece massive brass cage on rolling elements, additional designation M, guided on outer ring has additional designation MA, and the one guided on inner ring has additional designation MB
- Massive cage of polyamide or similar plastic, stiffened by glass fibres, guided on rolling elements, additional designation TNG

Special locations require bearings with cages provided with surface treatment, delivery of which must be discussed in advance with the supplier.

Minimum load

Cylindrical roller bearings must be exposed to certain minimum load, especially when operated at high revolutions and rapid load changes. In these cases, inertial effects of cage with rolling elements become mostly apparent which are indicated mainly by slippage or the rolling elements in the bearing.

Minimum radial load recommended for ZKL cylindrical roller bearings is such that equals to 2% of the dynamic load bearing capacity of the bearing.

Axial dynamic load rating

Bearings with flanges on both sides can, besides radial load, transfer also limited axial load. Considering the fact that the allowed load of bearings in axial direction depends on a number of factors that cannot be captured in a single calculation, the following relations have indicative character only.

In this case, axial load bearing capacity is not limited by material fatigue but by the load bearing capacity of the grease film in the contact surface between the roller face and guide flange, lubrication conditions, service temperature and possibilities of cooling of the bearing. In usual service conditions when the temperature difference between the bearing and ambient area does not exceed 60 °C at specific heat passage of 0.5 mWmm⁻²°C⁻¹, at minimum value of viscosity rate Z, the maximum admissible axial load can be calculated with sufficient accuracy from the below equation:

for lubrication with oil

$$F_{a \max} = \frac{0.5 C_{or} \cdot 10^4}{n (d + D)} - 0.05 F_r \quad [\text{kN}]$$

for lubrication with grease

$$F_{a \max} = \frac{0.35 C_{or} \cdot 10^4}{n (d + D)} - 0.03 F_r \quad [\text{kN}]$$

$F_{a \max}$ maximum admissible axial load [kN]

C_{or} basic radial static load rating [kN]

F_r radial load of bearings [kN]

n rotational frequency [min⁻¹]

d bearing bore diameter [mm]

D outer diameter of bearing [mm]

The $F_{a\max}$ values calculated according to the above stated equations apply on condition of acting of constant axial force. In case of interrupted load or impact load the admissible axial load can grow by two or three times towards the calculated value.

At acting axial load cylindrical roller bearings operate reliably only if the bearings are loaded radially at the same time. The relation $F_a/F_r \leq 0.5$ has to be maintained.

Equivalent dynamic load of bearing

Axially free N and NU type bearings are capable of transferring radial load only; the following applies to these bearings:



$$P = F_r$$

Axially guiding NJ, NUP, NH and NUJ type bearings are capable of transferring both radial and axial load; the following applies to these bearings:

$$P = F_r \quad \text{pro } F_a/F_r \leq e$$

$$P = 0.92 F_r + Y F_a \quad \text{pro } F_a/F_r > e$$

the arithmetic coefficient e = 0.2 for bearings of series 10, 18, 19, 2, 3 and 4

..... = 0.3 for bearings of other series

and axial load coefficient Y = 0.6 for bearings of series 10, 18, 19, 2, 3 and 4

..... = 0.4 for bearings of other series

Equivalent static load of bearing

$$P_0 = F_r$$

Additional designations

Supplementary characters before basic designation

L separate detachable ring of bearing

R Separable bearing without detachable ring

K Cage with rolling elements

T Case hardening steel

X Stainless steel



Supplementary characters behind the basic designation:

Radial clearance: Normal radial clearance is usually not presented in the bearing's designation.

- C2** Radial clearance smaller than normal
- C3** Radial clearance bigger than normal
- C4** Radial clearance bigger than C3
- C5** Radial clearance bigger than C4
- R** Radial clearance in non-standardised range (range in μm)

Construction design:

- E** Optimised inner design with higher load rating
- N** Snap ring groove on the outer ring
- NR** Snap ring groove on the outer ring and inserted snap ring
- N1** One snap ring groove on the outer ring face
- N2** Two snap ring grooves by 180° on one outer ring face

Material of the cage:

- J** Cage pressed from steel plate, guided on rolling elements
- F** Massive steel cage guided on rolling elements
- M** Massive brass cage guided on rolling elements
- L** Massive light metal cage guided on rolling elements
- TN** Massive cage of polyamide or similar plastic guided on rolling elements
- TNG** Massive cage of polyamide or similar plastic, reinforced by glass fibres, guided on rolling elements

Cage design (stated characters are always used in combination with cage material characters).

- A Cage guided on outer ring
- B Cage guided on inner ring
- P Compact window cage
- S Cage with lubrication slots
- R Silver-plated cage

Dimension stabilisation:

- S0 For service temperature to 150 °C
- S1 For service temperature to 200 °C
- S2 For service temperature to 250 °C



Single row cylindrical roller bearings d = 20 to 1180 mm

d = 20 to 25 mm

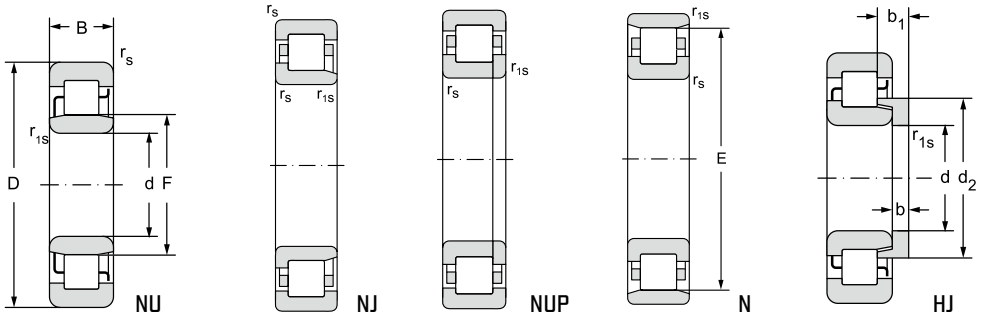

12.4.1

Main dimensions											Bearing designation	Other cages	Angle ring designation	Basic load rating	
d	D	B	r _s	r _{1s}	F	E	d ₂	b	b ₁	s ₁₎				C _r	C _{or}
			min	min				max				kN			
20	47	14,00	1,0	0,6	27		30,0	3,0	6,75	1,4	NU204		HJ204	13,9	10,2
	47	14,00	1,0	0,6	27		30,0	3,0	6,75	1,4	NJ204		HJ204	13,9	10,2
	47	14,00	1,0	0,6	27					1,4	NUP204			13,9	10,2
	47	14,00	1,0	0,6		40,0				1,4	N204			13,9	10,2
25	52	15,00	1,0	0,6	32		35,0	3,0	7,25	1,5	NU205		HJ205	15,8	12,6
	52	15,00	1,0	0,6	32		35,0	3,0	7,25	1,5	NJ205		HJ205	15,8	12,6
	52	15,00	1,0	0,6	32					1,5	NUP205			15,8	12,6
	52	15,00	1,0	0,6		45,0				1,5	N205			15,8	12,6
	52	15,00	1,0	0,6	31,5		34,9	3,0	6,00	1,4	NU205E	TNG	HJ205E	29,3	25,6
	52	15,00	1,0	0,6	31,5		34,9	3,0	6,00	1,4	NJ205E	TNG	HJ205E	29,3	25,6
	52	15,00	1,0	0,6	31,5					1,4	NUP205E	TNG		29,3	25,6
	52	15,00	1,0	0,6		46,5				1,4	N205ETNG			29,3	25,6
	52	18,00	1,0	0,6	32					1,6	NU2205			22,4	19,6
	52	18,00	1,0	0,6	32					1,6	NJ2205			22,4	19,6
	52	18,00	1,0	0,6	32					1,6	NUP2205			22,4	19,6
	62	17,00	1,1	1,1	35		39,3	4,0	8,00	1,4	NU305		HJ305	27,6	21,5
	62	17,00	1,1	1,1	35		39,3	4,0	8,00	1,4	NJ305		HJ305	27,6	21,5
	62	17,00	1,1	1,1	35					1,4	NUP305			27,6	21,5
	62	17,00	1,1	1,1		53,0				1,4	N305			27,6	21,5
	62	17,00	1,1	1,1	34		38,3	4,0	7,00	1,4	NU305EMAS	TNG	HJ305E	43,0	36,2
	62	17,00	1,1	1,1	34		38,3	4,0	7,00	1,4	NJ305EMAS	TNG	HJ305E	43,0	36,2
	62	17,00	1,1	1,1	34					1,4	NUP305EMAS	TNG		43,0	36,2
	62	17,00	1,1	1,1	34	54,0				1,4	N305ETNG			43,0	36,2
	80	21,00	1,5	1,5	38,8					1,4	NU405			43,8	34,1
	80	21,00	1,5	1,5	38,8					1,4	NJ405			43,8	34,1

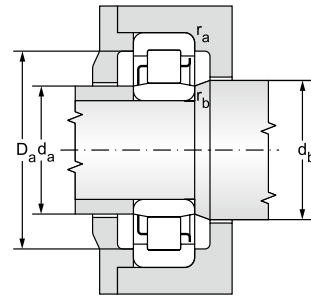
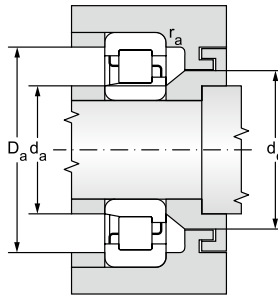
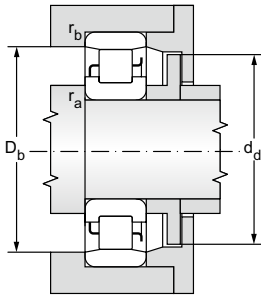

¹⁾ Admissible axial movement

Fatigue load limit	Limiting speed for lubrication with		Abutment and fillet dimensions										Weight		
	P_u	grease	oil	d	d_a	d_a	d_b	d_c	d_d	D_a	D_b	r_a	r_b	~	Ang.r.
kN	min^{-1}			min	max	min	min	max	max	min	max	max	of bearing	kg	
1,24	14000	17000	20	25	25,5	29,0	32	-	42	-	1,0	0,6	0,11	0,0100	
1,24	14000	17000		25	25,5	29,0	32	-	42	-	1,0	0,6	0,11	0,0100	
1,24	14000	17000		25	25,5	29,0	32	-	42	-	1,0	0,6	0,11		
1,24	14000	17000		25	25,5	29,0	32	39	42	42	1,0	0,6	0,11		
1,54	12600	15000	25	30	30,5	34,0	37	-	47	-	1,0	0,6	0,13	0,020	
1,54	12600	15000		30	30,5	34,0	37	-	47	-	1,0	0,6	0,13	0,020	
1,54	12600	15000		30	30,5	34,0	37	-	47	-	1,0	0,6	0,13		
1,54	12600	15000		30	30,5	34,0	37	43	47	47	1,0	0,6	0,13		
3,12	12600	15000		30	30,0	34,0	37	-	47	-	1,0	0,6	0,13	0,020	
3,12	12600	15000		30	30,0	34,0	37	-	47	-	1,0	0,6	0,13	0,020	
3,12	12600	15000		30	30,0	34,0	37	-	47	-	1,0	0,6	0,13		
3,12	12600	15000		30	30,0	34,0	37	44	47	47	1,0	0,6	0,13		
2,39	12600	15000		30	30,5	34,0	37	-	47	-	1,0	0,6	0,16		
2,39	12600	15000		30	30,5	34,0	37	-	47	-	1,0	0,6	0,16		
2,39	12600	15000		30	30,5	34,0	37	-	47	-	1,0	0,6	0,16		
2,62	10000	12000		31	33,0	37,0	40	-	55	-	1,0	1,0	0,24	0,030	
2,62	10000	12000		31	33,0	37,0	40	-	55	-	1,0	1,0	0,24	0,030	
2,62	10000	12000		31	33,0	37,0	40	-	55	-	1,0	1,0	0,24		
2,62	10000	12000		31	33,0	37,0	40	51	55	55	1,0	1,0	0,24		
4,41	10000	12000		31	32,0	37,0	40	-	55	-	1,0	1,0	0,26	0,030	
4,41	10000	12000		31	32,0	37,0	40	-	55	-	1,0	1,0	0,26	0,030	
4,41	10000	12000		31	32,0	37,0	40	-	55	-	1,0	1,0	0,26		
4,41	10000	12000		31	32,0	36,0	39	52	55	55	1,0	1,0	0,24		
4,16	8400	10000		32	38,0	39,0	40	-	73	-	1,0	1,0	0,57		
4,16	8400	10000		32	38,0	39,0	40	-	73	-	1,0	1,0	0,57		

Single row cylindrical roller bearings

d = 30 to 32 mm

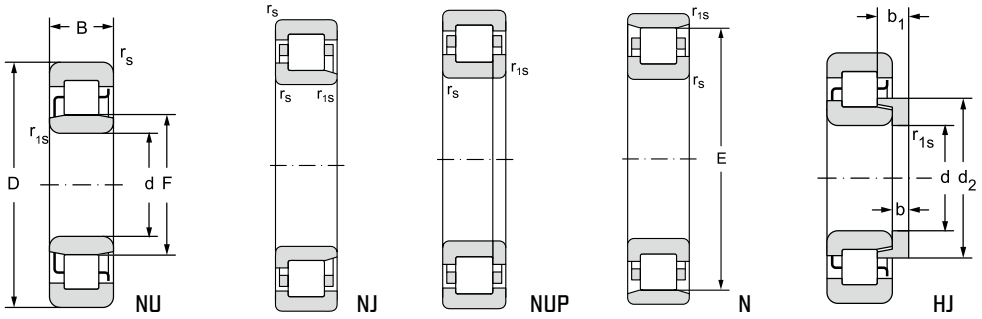

Main dimensions											Bearing designation	Other cages	Angle ring designation	Basic load rating			
d	D	B	r _s	r _{1s}	F	E	d ₂	b	b ₁	s ₁				C _r	C _{or}		
			min	min			max				kN						
12.4.1	30	62	16,00	1,0	0,6	38,5		42,2	4,0	8,25	1,5		NU206		HJ206	21,5	17,8
		62	16,00	1,0	0,6	38,5		42,2	4,0	8,25	1,5		NJ206		HJ206	21,5	17,8
		62	16,00	1,0	0,6	38,5					1,5		NUP206			21,5	17,8
		62	16,00	1,0	0,6		53,5				1,5		N206			21,5	17,8
		62	16,00	1,0	0,6	37,5		41,4	4,0	7,00	1,4		NU206ETNG		HJ206E	39,1	35,5
		62	16,00	1,0	0,6	37,5		41,4	4,0	7,00	1,4		NJ206ETNG		HJ206E	39,1	35,5
		62	16,00	1,0	0,6	37,5					1,4		NUP206ETNG			39,1	35,5
		62	16,00	1,0	0,6		55,5				1,4		N206ETNG			39,1	35,5
		62	20,00	1,0	0,6	38,5					1,6		NU2206			31,6	29,3
		62	20,00	1,0	0,6	38,5					1,6		NJ2206			31,6	29,3
		62	20,00	1,0	0,6	38,5					1,6		NUP2206			31,6	29,3
		72	19,00	1,1	1,1	42		46,6	5,0	9,50	1,4		NU306		HJ306	36,2	31,0
		72	19,00	1,1	1,1	42		46,6	5,0	9,50	1,4		NJ306		HJ306	36,2	31,0
		72	19,00	1,1	1,1	42					1,4		NUP306			36,2	31,0
		72	19,00	1,1	1,1		62,0				1,4		N306			36,2	31,0
		72	19,00	1,1	1,1	40,5		45,1	5,0	8,50	1,4		NU306E	TNG	HJ306E	53,1	46,4
	72	19,00	1,1	1,1	40,5		45,1	5,0	8,50	1,4		NJ306E	TNG	HJ306E	53,1	46,4	
	72	19,00	1,1	1,1	40,5					1,4		NUP306E	TNG		53,1	46,4	
	72	19,00	1,1	1,1		62,5				1,4		N306ETNG			53,1	46,4	
	90	23,00	1,5	1,5	45		51,4	7,0	11,50	1,5		NU406		HJ406	59,6	48,2	
	90	23,00	1,5	1,5	45		51,4	7,0	11,50	1,5		NJ406		HJ406	59,6	48,2	
	90	23,00	1,5	1,5	45					1,5		NUP406			59,6	48,2	
	32	65	21,00	1,0	0,6	38,5					1,6		NU22/32ETNG			51,1	50,1

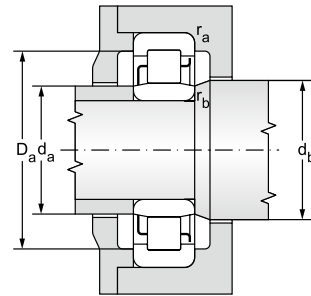
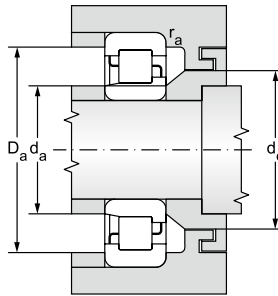
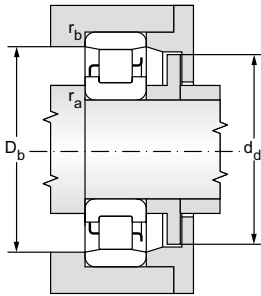

¹⁾ Admissible axial movement

Fatigue load limit	Limiting speed for lubrication with		Abutment and fillet dimensions										Weight		
	P_u	grease	oil	d	d_a	d_a	d_b	d_c	d_d	D_a	D_b	r_a	r_b	~	Ang.r.
kN	min^{-1}			min	max	min	min	max	max	min	max	max	max	of bearing	kg
2,17	10600	12600	30	35	37,0	40,0	44	-	57	-	1,0	0,6		0,20	0,030
2,17	10600	12600		35	37,0	40,0	44	-	57	-	1,0	0,6		0,20	0,030
2,17	10600	12600		35	37,0	40,0	44	-	57	-	1,0	0,6		0,20	
2,17	10600	12600		35	37,0	40,0	44	52	57	56	1,0	0,6		0,20	
4,33	10600	12600		35	37,0	40,0	43	-	57	-	1,0	0,6		0,20	0,030
4,33	10600	12600		35	37,0	40,0	43	-	57	-	1,0	0,6		0,20	0,030
4,33	10600	12600		35	37,0	40,0	43	-	57	-	1,0	0,6		0,20	
4,33	10600	12600		35	37,0	40,0	43	54	57	57	1,0	0,6		0,20	
3,57	10600	12600		35	37,0	40,0	44	-	57	-	1,0	0,6		0,26	
3,57	10600	12600		35	37,0	40,0	44	-	57	-	1,0	0,6		0,26	
3,57	10600	12600		35	37,0	40,0	44	-	57	-	1,0	0,6		0,26	
3,78	8900	10600		36	39,0	44,0	48	-	65	-	1,0	1,0		0,36	0,040
3,78	8900	10600		36	39,0	44,0	48	-	65	-	1,0	1,0		0,36	0,040
3,78	8900	10600		36	39,0	44,0	48	-	65	-	1,0	1,0		0,36	
3,78	8900	10600		36	39,0	44,0	48	60	65	64	1,0	1,0		0,36	
5,66	8400	10000		36	37,5	43,0	47	-	65	-	1,0	1,0		0,36	0,040
5,66	8400	10000		36	37,5	43,0	47	-	65	-	1,0	1,0		0,36	0,040
5,66	8400	10000		36	37,5	43,0	47	-	65	-	1,0	1,0		0,36	
5,66	8400	10000		36	37,5	43,0	47	60	65	64	1,0	1,0		0,36	
5,88	7100	8400		39	41,0	47,0	53	-	80	-	1,5	1,5		0,75	0,080
5,88	7100	8400		39	41,0	47,0	53	-	80	-	1,5	1,5		0,75	0,080
5,88	7100	8400		39	41,0	47,0	53	-	80	-	1,5	1,5		0,75	
6,11	10000	12000	32	35	37,0	39,0	43	-	60	-	1,0	1,0		0,31	

Single row cylindrical roller bearings

d = 35 mm

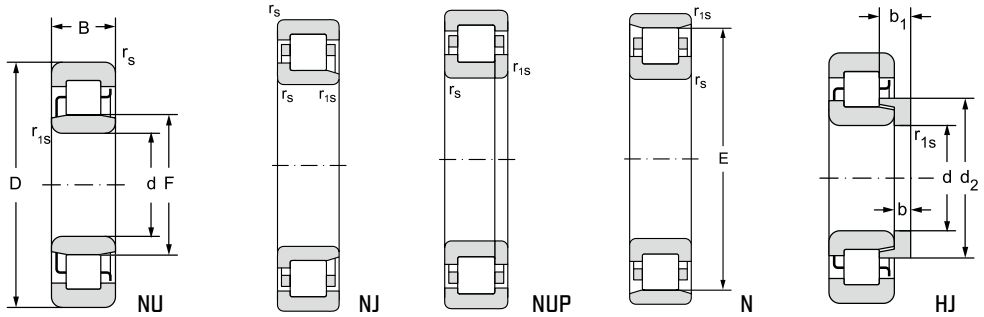

Main dimensions											Bearing designation	Other cages	Angle ring designation	Basic load rating			
d	D	B	r _s	r _{1s}	F	E	d ₂	b	b ₁	s ₁				C _r	C _{or}		
			min	min				max				kN					
12.4.1	35	72	17,00	1,1	0,6	43,8		48,1	4,0	8,00	1,5		NU207		HJ207	31,6	27,1
		72	17,00	1,1	0,6	43,8		48,1	4,0	8,00	1,5		NJ207		HJ207	31,6	27,1
	72	17,00	1,1	0,6	43,8						1,5		NUP207			31,6	27,1
	72	17,00	1,1	0,6		61,8					1,5		N207			31,6	27,1
	72	17,00	1,1	0,6	44		48,3	4,0	7,00	1,4			NU207E	TNG	HJ207E	51,1	48,2
	72	17,00	1,1	0,6	44		48,3	4,0	7,00	1,4			NJ207E	TNG	HJ207E	51,1	48,2
	72	17,00	1,1	0,6	44					1,4			NUP207E	TNG		51,1	48,2
	72	17,00	1,1	0,6		64,0				1,4			N207ETNG			51,1	48,2
	72	23,00	1,1	0,6	43,8					1,6			NU2207			48,2	47,3
	72	23,00	1,1	0,6	43,8					1,6			NJ2207			48,2	47,3
	72	23,00	1,1	0,6	43,8					1,6			NUP2207			48,2	47,3
	72	23,00	1,1	0,6	44					1,6			NU2207ETNG			64,3	64,3
	72	23,00	1,1	0,6	44					1,6			NJ2207ETNG			64,3	64,3
	72	23,00	1,1	0,6	44					1,6			NUP2207ETNG			64,3	64,3
	80	21,00	1,5	1,1	46,2		51,2	6,0	11,00	1,4			NU307		HJ307	43,0	36,2
	80	21,00	1,5	1,1	46,2		51,2	6,0	11,00	1,4			NJ307		HJ307	43,0	36,2
	80	21,00	1,5	1,1	46,2					1,4			NUP307			43,0	36,2
	80	21,00	1,5	1,1		68,2				1,4			N307			43,0	36,2
	80	21,00	1,5	1,1	46,2		51,2	6,0	9,50	1,4			NU307E		HJ307E	66,8	61,9
	80	21,00	1,5	1,1	46,2		51,2	6,0	9,50	1,4			NJ307E		HJ307E	66,8	61,9
	80	21,00	1,5	1,1	46,2					1,4			NUP307E			66,8	61,9
	80	31,00	1,5	1,1	46,2					2,7			NU2307EMAS			92,6	92,6
	80	31,00	1,5	1,1	46,2					2,7			NJ2307EMAS			92,6	92,6
	80	31,00	1,5	1,1	46,2					2,7			NUP2307EMAS			92,6	92,6
	100	25,00	1,5	1,5	53		59,9	8,0	13,00	1,5			NU407		HJ407	75,0	64,3
	100	25,00	1,5	1,5	53		59,9	8,0	13,00	1,5			NJ407		HJ407	75,0	64,3
	100	25,00	1,5	1,5	53					1,5			NUP407			75,0	64,3
	100	25,00	1,5	1,5		83,0				1,5			N407			75,0	64,3

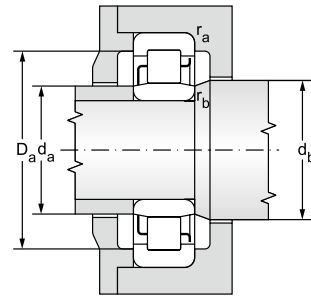
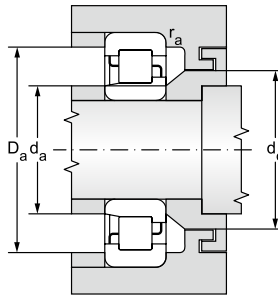
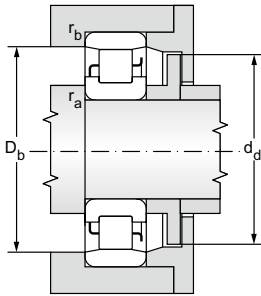

¹⁾ Admissible axial movement

Fatigue load limit	Limiting speed for lubrication with		Abutment and fillet dimensions										Weight		
	P_u	grease	oil	d	d_a	d_a	d_b	d_c	d_d	D_a	D_b	r_a	r_b	~	Ang.r.
kN	min^{-1}			min	max	min	min	max	max	min	max	max	max	of bearing	
				mm											
3,30	9400	11000	35	42	42,0	46,0	50	-	65	-	1,0	0,6		0,29	0,040
3,30	9400	11000		42	42,0	46,0	50	-	65	-	1,0	0,6		0,29	0,040
3,30	9400	11000		42	42,0	46,0	50	-	65	-	1,0	0,6		0,29	0,040
3,30	9400	11000		42	42,0	46,0	50	60	65	64	1,0	0,6		0,29	0,040
5,88	8900	10600		42	42,0	46,0	50	-	65	-	1,0	0,6		0,29	0,040
5,88	8900	10600		42	42,0	46,0	50	-	65	-	1,0	0,6		0,29	0,040
5,88	8900	10600		42	42,0	46,0	50	-	65	-	1,0	0,6		0,29	0,040
5,88	8900	10600		42	42,0	46,0	50	62	65	65	1,0	0,6		0,29	0,040
5,77	9400	11000		42	42,0	46,0	50	-	65	-	1,0	0,6		0,40	0,040
5,77	9400	11000		42	42,0	46,0	50	-	65	-	1,0	0,6		0,40	0,040
5,77	9400	11000		42	42,0	46,0	50	-	65	-	1,0	0,6		0,40	0,040
7,84	8900	10600		42	42,0	46,0	50	-	65	-	1,0	0,6		0,39	0,040
7,84	8900	10600		42	42,0	46,0	50	-	65	-	1,0	0,6		0,39	0,040
7,84	8900	10600		42	42,0	46,0	50	-	65	-	1,0	0,6		0,39	0,040
4,41	7900	9400		42	44,0	48,0	53	-	71	-	1,5	1,0		0,48	0,060
4,41	7900	9400		42	44,0	48,0	53	-	71	-	1,5	1,0		0,48	0,060
4,41	7900	9400		42	44,0	48,0	53	-	71	-	1,5	1,0		0,48	0,060
4,41	7900	9400		42	44,0	48,0	53	66	71	71	1,5	1,0		0,48	0,060
7,55	7500	8900		42	44,0	48,0	53	-	71	-	1,5	1,0		0,47	0,060
7,55	7500	8900		42	44,0	48,0	53	-	71	-	1,5	1,0		0,47	0,060
7,55	7500	8900		42	44,0	48,0	53	-	71	-	1,5	1,0		0,47	0,060
11,29	7100	8400		42	44,0	48,0	53	-	71	-	1,5	1,0		0,75	0,060
11,29	7100	8400		42	44,0	48,0	53	-	71	-	1,5	1,0		0,75	0,060
11,29	7100	8400		42	44,0	48,0	53	-	71	-	1,5	1,0		0,75	0,060
7,84	6300	7500		44	52,0	55,0	62	-	90	-	1,5	1,5		1,00	0,13
7,84	6300	7500		44	52,0	55,0	62	-	90	-	1,5	1,5		1,00	0,13
7,84	6300	7500		44	52,0	55,0	62	-	90	-	1,5	1,5		1,00	0,13
7,84	6300	7500		44	52,0	55,0	62	81	90	86	1,5	1,5		1,00	0,13

Single row cylindrical roller bearings

d = 40 mm

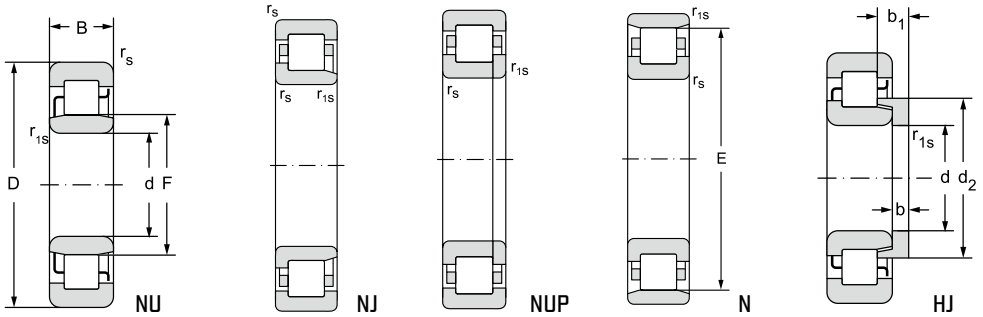

12.4.1

Main dimensions											Bearing designation	Other cages	Angle ring designation	Basic load rating			
d	D	B	r _s	r _{1s}	F	E	d ₂	b	b ₁	s ₁)				C _r	C _{or}		
			min	min				max				kN					
40	80	18,00	1,1	1,1	50		54,6	5,0	9,00	1,5			NU208		HJ208	42,2	37,6
	80	18,00	1,1	1,1	50		54,6	5,0	9,00	1,5			NJ208		HJ208	42,2	37,6
	80	18,00	1,1	1,1	50					1,5			NUP208			42,2	37,6
	80	18,00	1,1	1,1		70,0				1,5			N208			42,2	37,6
	80	18,00	1,1	1,1	49,5		54,1	5,0	8,50	1,4			NU208E		HJ208E	54,1	50,1
	80	18,00	1,1	1,1	49,5		54,1	5,0	8,50	1,4			NJ208E		HJ208E	54,1	50,1
	80	18,00	1,1	1,1	49,5					1,4			NUP208E			54,1	50,1
	80	23,00	1,1	1,1	50					1,6			NU2208			57,3	56,2
	80	23,00	1,1	1,1	50					1,6			NJ2208			57,3	56,2
	80	23,00	1,1	1,1	50					1,6			NUP2208			57,3	56,2
	80	30,16	1,0	1,5	49,3					3,0			NU5208M			57,0	98,1
	90	23,00	1,5	1,5	53,5		59,0	7,0	12,50	1,4			NU308		HJ308	55,2	48,2
	90	23,00	1,5	1,5	53,5		59,0	7,0	12,50	1,4			NJ308		HJ308	55,2	48,2
	90	23,00	1,5	1,5	53,5					1,4			NUP308			55,2	48,2
	90	23,00	1,5	1,5		77,5				1,4			N308			55,2	48,2
	90	23,00	1,5	1,5	52		57,7	7,0	11,00	1,4			NU308E	TNG	HJ308E	84,1	77,9
	90	23,00	1,5	1,5	52		57,7	7,0	11,00	1,4			NJ308E	TNG	HJ308E	84,1	77,9
	90	23,00	1,5	1,5	52					1,4			NUP308E	TNG		84,1	77,9
	90	23,00	1,5	1,5		80,0				1,4			N308ETNG			84,1	77,9
	90	33,00	1,5	1,5	52					2,9			NU2308EMAS			119,0	123,0
	90	33,00	1,5	1,5	52					2,9			NJ2308EMAS			119,0	123,0
	90	33,00	1,5	1,5	52					2,9			NUP2308EMAS			119,0	123,0
	110	27,00	2,0	2,0	58		65,8	8,0	13,00	1,5			NU408		HJ408	92,6	79,4
	110	27,00	2,0	2,0	58		65,8	8,0	13,00	1,5			NJ408		HJ408	92,6	79,4
	110	27,00	2,0	2,0	58					1,5			NUP408			92,6	79,4
	110	27,00	2,0	2,0		92,0				1,5			N408			92,6	79,4

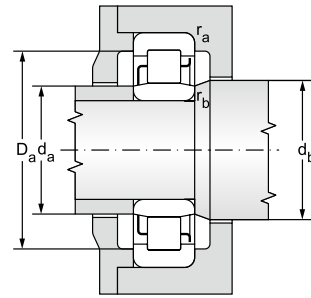
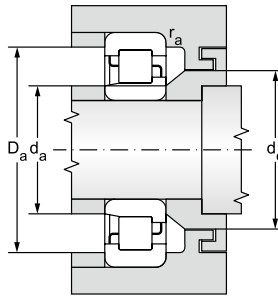
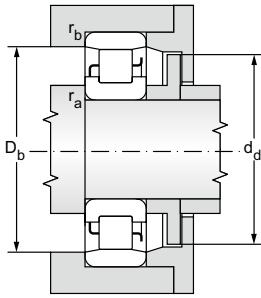

¹⁾ Admissible axial movement

Fatigue load limit	Limiting speed for lubrication with		Abutment and fillet dimensions										Weight			
	P_u	grease	oil	d	d_a	d_a	d_b	d_c	d_d	D_a	D_b	r_a	r_b	~	of bearing	Ang.r.
kN	min^{-1}			mm										kg		
				min	max	min	min	max	max	min	max	max	max			
4,59	7900	9400	40	47	48,0	52,0	56	-	73	-	1,0	1,0	0,37	0,050		
4,59	7900	9400		47	48,0	52,0	56	-	73	-	1,0	1,0	0,37	0,050		
4,59	7900	9400		47	48,0	52,0	56	-	73	-	1,0	1,0	0,0000			
4,59	7900	9400		47	48,0	52,0	56	68	73	72	1,0	1,0	0,0000			
6,11	7900	9400		47	47,0	51,0	56	-	73	-	1,0	1,0	0,38	0,050		
6,11	7900	9400		47	47,0	51,0	56	-	73	-	1,0	1,0	0,38	0,050		
6,11	7900	9400		47	47,0	51,0	56	-	73	-	1,0	1,0	0,38			
6,85	7900	9400		47	48,0	52,0	56	-	73	-	1,0	1,0	0,74			
6,85	7900	9400		47	48,0	52,0	56	-	73	-	1,0	1,0	0,74			
6,85	7900	9400		47	48,0	52,0	56	-	73	-	1,0	1,0	0,74			
11,96	7500	8900		48	-	51,5		-	72	-	1,5	1,5	0,74			
5,88	7100	8400		47	51,0	55,0	61	-	81	-	1,5	1,5	0,66	0,090		
5,88	7100	8400		47	51,0	55,0	61	-	81	-	1,5	1,5	0,66	0,090		
5,88	7100	8400		47	51,0	55,0	61	-	81	-	1,5	1,5	0,66			
5,88	7100	8400		47	51,0	55,0	61	75	81	81	1,5	1,5	0,66			
9,50	6700	7900		47	50,0	54,0	60	-	81	-	1,5	1,5	0,67	0,080		
9,50	6700	7900		47	50,0	54,0	60	-	81	-	1,5	1,5	0,67	0,080		
9,50	6700	7900		47	50,0	54,0	60	-	81	-	1,5	1,5	0,67			
9,50	6700	7900		47	50,0	54,0	60	77	81	81	1,5	1,5	0,83			
15,00	6300	7500		47	50,0	54,0	60	-	81	-	1,5	1,5	1,00			
15,00	6300	7500		47	50,0	54,0	60	-	81	-	1,5	1,5	1,00			
15,00	6300	7500		47	50,0	54,0	60	-	81	-	1,5	1,5	1,00			
9,68	5600	6700		50	55,0	60,0	68	-	97	-	2,0	2,0	1,30	0,14		
9,68	5600	6700		50	55,0	60,0	68	-	97	-	2,0	2,0	1,30	0,14		
9,68	5600	6700		50	55,0	60,0	68	-	97	-	2,0	2,0	1,30			
9,68	5600	6700		50	55,0	60,0	68	90	97	95	2,0	2,0	1,30			

Single row cylindrical roller bearings

d = 45 mm

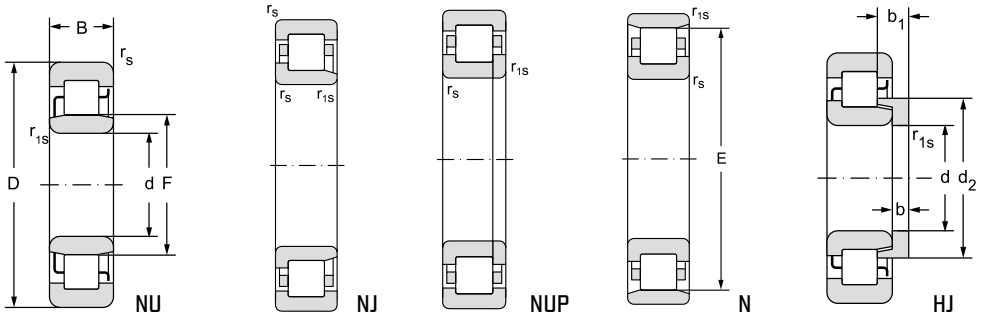

12.4.1

Main dimensions											Bearing designation	Other cages	Angle ring designation	Basic load rating		
d	D	B	r _s	r _{1s}	F	E	d ₂	b	b ₁	s ₁				C _r	C _{or}	
			min	min			max				kN					
45	85	19,00	1,1	1,1	55		59,6	5,0	9,50	1,5		NU209		HJ209	43,8	41,1
	85	19,00	1,1	1,1	55		59,6	5,0	9,50	1,5		NJ209		HJ209	43,8	41,1
	85	19,00	1,1	1,1	55					1,5		NUP209			43,8	41,1
	85	19,00	1,1	1,1		75,0				1,5		N209			43,8	41,1
	85	19,00	1,1	1,1	54,5		59,1	5,0	8,50	1,4		NU209E	TNG	HJ209E	61,9	60,7
	85	19,00	1,1	1,1	54,5		59,1	5,0	8,50	1,4		NJ209E	TNG	HJ209E	61,9	60,7
	85	19,00	1,1	1,1	54,5					1,4		NUP209E	TNG		61,9	60,7
	85	19,00	1,1	1,1		76,5				1,4		N209ETNG			61,9	60,7
	85	23,00	1,1	1,1	54,5					1,6		NU2209E	TNG		76,4	79,4
	85	23,00	1,1	1,1	54,5					1,6		NJ2209E	TNG		76,4	79,4
	85	23,00	1,1	1,1	54,5					1,6		NUP2209E	TNG		76,4	79,4
	85	30,16	1,0	1,5	55,52					4,0		NU5209M			89,1	117,7
	100	25,00	1,5	1,5	58,5		65,0	7,0	12,50	1,4		NU309		HJ309	70,8	61,9
	100	25,00	1,5	1,5	58,5		65,0	7,0	12,50	1,4		NJ309		HJ309	70,8	61,9
	100	25,00	1,5	1,5	58,5					1,4		NUP309			70,8	61,9
	100	25,00	1,5	1,5		86,5				1,4		N309			70,8	61,9
	100	25,00	1,5	1,5	58,5		64,6	7,0	11,50	1,4		NU309E		HJ309E	102,0	98,0
	100	25,00	1,5	1,5	58,5		64,6	7,0	11,50	1,4		NJ309E		HJ309E	102,0	98,0
	100	25,00	1,5	1,5	58,5					1,4		NUP309E			102,0	98,0
	100	36,00	1,5	1,5	58,5					2,9		NU2309E			139,0	147,0
	100	36,00	1,5	1,5	58,5					2,9		NJ2309E			139,0	147,0
	100	36,00	1,5	1,5	58,5					2,9		NUP2309E			139,0	147,0
	120	29,00	2,0	2,0	64,5		72,8	8,0	13,50	1,5		NU409		HJ409	104,0	90,9
	120	29,00	2,0	2,0	64,5		72,8	8,0	13,50	1,5		NJ409		HJ409	104,0	90,9
	120	29,00	2,0	2,0	64,5					1,5		NUP409			104,0	90,9
	120	29,00	2,0	2,0		100,5				1,5		N409			104,0	90,9

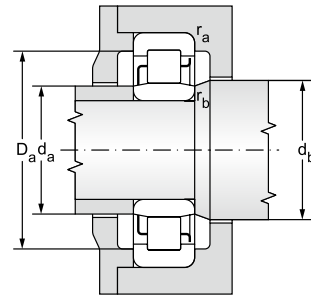
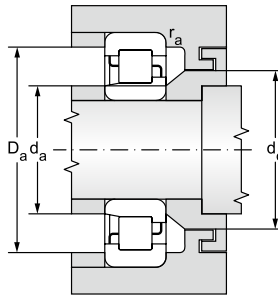
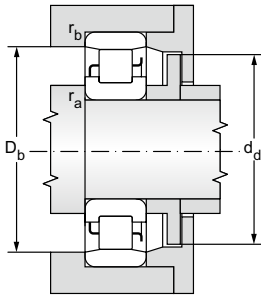

¹⁾ Admissible axial movement

Fatigue load limit	Limiting speed for lubrication with		Abutment and fillet dimensions										Weight		
	P_u	grease	oil	d	d_a	d_a	d_b	d_c	d_d	D_a	D_b	r_a	r_b	~	Ang.r.
kN	min^{-1}			min	max	min	min	max	max	min	max	max	of bearing		
				mm										kg	
5,01	7500	8900	45	52	53,0	57,0	61	-	78	-	1,0	1,0	0,43	0,050	
5,01	7500	8900		52	53,0	57,0	61	-	78	-	1,0	1,0	0,43	0,050	
5,01	7500	8900		52	53,0	57,0	61	74	78	78	1,0	1,0	0,43		
7,40	7500	8900		52	53,0	57,0	61	-	78	-	1,0	1,0	0,45	0,050	
7,40	7500	8900		52	53,0	57,0	61	-	78	-	1,0	1,0	0,45	0,050	
7,40	7500	8900		52	53,0	57,0	61	-	78	-	1,0	1,0	0,45		
7,40	7500	8900		52	53,0	57,0	61	74	78	78	1,0	1,0	0,43		
9,68	7100	8400		52	53,0	57,0	61	-	78	-	1,0	1,0	0,55		
9,68	7100	8400		52	53,0	57,0	61	-	78	-	1,0	1,0	0,55		
9,68	7100	8400		53	53,0	57,0	61	-	76	-	1,5	1,0	0,55		
14,35	6700	7900		53	-	57,0	-	-	76	-	1,5	1,0	0,80		
7,55	6300	7500		52	56,0	60,0	66	-	91	-	1,5	1,5	0,87	0,100	
7,55	6300	7500		52	56,0	60,0	66	-	91	-	1,5	1,5	0,87	0,100	
7,55	6300	7500		52	56,0	60,0	66	-	91	-	1,5	1,5	0,87		
7,55	6300	7500		52	56,0	60,0	66	84	91	90	1,5	1,5	0,87		
11,95	6000	7100		52	56,0	60,0	66	-	91	-	1,5	1,5	0,89	0,100	
11,95	6000	7100		52	56,0	60,0	66	-	91	-	1,5	1,5	0,89	0,100	
11,95	6000	7100		52	56,0	60,0	66	-	91	-	1,5	1,5	0,89		
17,93	5600	6700		52	56,0	60,0	66	-	91	-	1,5	1,5	1,36		
17,93	5600	6700		52	56,0	60,0	66	-	91	-	1,5	1,5	1,36		
17,93	5600	6700		52	56,0	60,0	66	-	91	-	1,5	1,5	1,36		
11,09	5300	6300		55	62,7	66,0	75	-	107	-	2,0	2,0	1,65	0,18	
11,09	5300	6300		55	62,7	66,0	75	-	107	-	2,0	2,0	1,65	0,18	
11,09	5300	6300		55	62,7	66,0	75	-	107	-	2,0	2,0	1,65		
11,09	5300	6300		55	62,7	66,0	75	99	107	103	2,0	2,0	1,65		

Single row cylindrical roller bearings

d = 50 mm

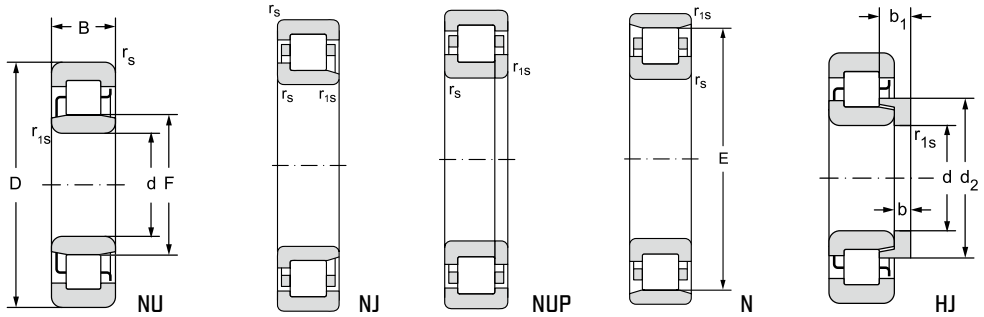

Main dimensions											Bearing designation	Other cages	Angle ring designation	Basic load rating				
d	D	B	r _s	r _{1s}	F	E	d ₂	b	b ₁	s ₁₎				C _r	C _{or}			
			min	min				max				kN						
12.4.1	50	90	20,00	1,1	1,1	59,5		64,6	5,0	9,00	1,6		NU210E		HJ210E	64,3	65,6	
		90	20,00	1,1	1,1	59,5		64,6	5,0	9,00	1,6		NJ210E		HJ210E	64,3	65,6	
		90	20,00	1,1	1,1	59,5							NUP210E			64,3	65,6	
		90	23,00	1,1	1,1	60,4							NU2210			63,1	66,8	
		90	23,00	1,1	1,1	60,4							NJ2210			63,1	66,8	
		90	23,00	1,1	1,1	60,4							NUP2210			63,1	66,8	
		90	23,00	1,1	1,1	59,5							NU2210E			84,1	90,9	
		90	23,00	1,1	1,1	59,5							NJ2210E			84,1	90,9	
		90	23,00	1,1	1,1	59,5							NUP2210E			84,1	90,9	
		90	30,16	1,0	1,5	60,46							NU5210M			92,6	128,0	
		110	27,00	2,0	2,0	65		71,9	8,0	14,00	1,5			NU310		HJ310	87,4	79,4
		110	27,00	2,0	2,0	65		71,9	8,0	14,00	1,5			NJ310		HJ310	87,4	79,4
		110	27,00	2,0	2,0	65								NUP310			87,4	79,4
		110	27,00	2,0	2,0	65	95,0							N310			87,4	79,4
		110	27,00	2,0	2,0	65		71,4	8,0	13,00	1,5			NU310ETNG		HJ310E	117,0	114,0
		110	27,00	2,0	2,0	65		71,4	8,0	13,00	1,5			NJ310ETNG		HJ310E	117,0	114,0
		110	27,00	2,0	2,0	65								NUP310ETNG			117,0	114,0
		110	27,00	2,0	2,0	65	97,0							N310ETNG			117,0	114,0
		110	40,00	2,0	2,0	65								NU2310			123,0	126,0
		110	40,00	2,0	2,0	65								NJ2310			123,0	126,0
	110	40,00	2,0	2,0	65								NUP2310			123,0	126,0	
	110	40,00	2,0	2,0	65								NU2310EMAS			168,0	178,0	
	110	40,00	2,0	2,0	65								NJ2310EMAS			168,0	178,0	
	110	40,00	2,0	2,0	65								NUP2310EMAS			168,0	178,0	
	130	31,00	2,1	2,1	70,8		80,0	9,0	14,50	2,0			NU410		HJ410	139,0	114,0	
	130	31,00	2,1	2,1	70,8		80,0	9,0	14,50	2,0			NJ410		HJ410	139,0	114,0	
	130	31,00	2,1	2,1	70,8								NUP410			139,0	114,0	
	130	31,00	2,1	2,1	110,8								N410			139,0	114,0	

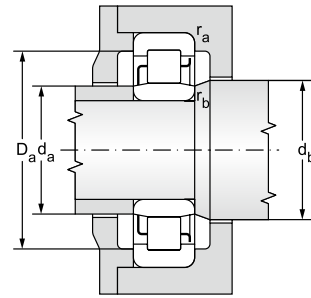
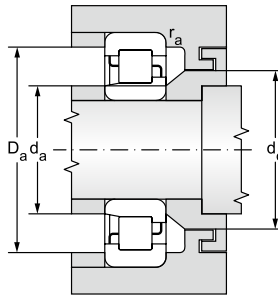
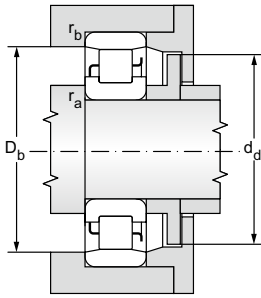

¹⁾ Admissible axial movement

Fatigue load limit	Limiting speed for lubrication with		Abutment and fillet dimensions										Weight		
	P_u	grease	oil	d	d_a	d_a	d_b	d_c	d_d	D_a	D_b	r_a	r_b	~	Ang.r.
kN	min^{-1}			min	max	min	min	max	max	min	max	max	max	of bearing	kg
8,00	6700	7900	50	57	57,0	61,0	66	-	83	-	1,0	1,0		0,49	0,060
8,00	6700	7900		57	57,0	61,0	66	-	83	-	1,0	1,0		0,49	0,060
8,00	6700	7900		57	57,0	61,0	66	-	83	-	1,0	1,0		0,49	
8,15	7100	8400		57	58,0	62,0	66	-	83	-	1,0	1,0		0,58	
8,15	7100	8400		57	58,0	62,0	66	-	83	-	1,0	1,0		0,58	
8,15	7100	8400		57	58,0	62,0	66	-	83	-	1,0	1,0		0,58	
11,09	6700	7900		57	57,0	61,0	66	-	83	-	1,0	1,0		0,59	
11,09	6700	7900		57	57,0	61,0	66	-	83	-	1,0	1,0		0,59	
11,09	6700	7900		57	57,0	61,0	66	-	83	-	1,0	1,0		0,59	
15,61	6300	7500		58	-	62,0	-	-	81	-	1,5	1,0		0,88	
9,68	5600	6700		60	63,0	67,0	74	-	100	-	2,0	2,0		1,15	0,15
9,68	5600	6700		60	63,0	67,0	74	-	100	-	2,0	2,0		1,15	0,15
9,68	5600	6700		60	63,0	67,0	74	-	100	-	2,0	2,0		1,15	
9,68	5600	6700		60	63,0	67,0	74	93	100	99	2,0	2,0		1,15	
13,90	5300	6300		60	63,0	67,0	74	-	100	-	2,0	2,0		1,13	0,14
13,90	5300	6300		60	63,0	67,0	74	-	100	-	2,0	2,0		1,13	0,14
13,90	5300	6300		60	63,0	67,0	74	-	100	-	2,0	2,0		1,13	
13,90	5300	6300		60	63,0	67,0	74	95	100	100	2,0	2,0		1,13	
15,37	5600	6700		60	63,0	67,0	74	-	100	-	2,0	2,0		0,17	
15,37	5600	6700		60	63,0	67,0	74	-	100	-	2,0	2,0		0,17	
15,37	5600	6700		60	63,0	67,0	74	-	100	-	2,0	2,0		0,17	
21,71	5000	6000		60	63,0	67,0	74	-	100	-	2,0	2,0		1,83	
21,71	5000	6000		60	63,0	67,0	74	-	100	-	2,0	2,0		1,83	
21,71	5000	6000		60	63,0	67,0	74	-	100	-	2,0	2,0		1,83	
13,90	4700	5600		63	68,0	73,0	82	-	116	-	2,0	2,0		2,00	0,23
13,90	4700	5600		63	68,0	73,0	82	-	116	-	2,0	2,0		2,00	0,23
13,90	4700	5600		63	68,0	73,0	82	-	116	-	2,0	2,0		2,00	
13,90	4700	5600		63	68,0	73,0	82	109	116	114	2,0	2,0		2,00	

Single row cylindrical roller bearings

d = 55 mm

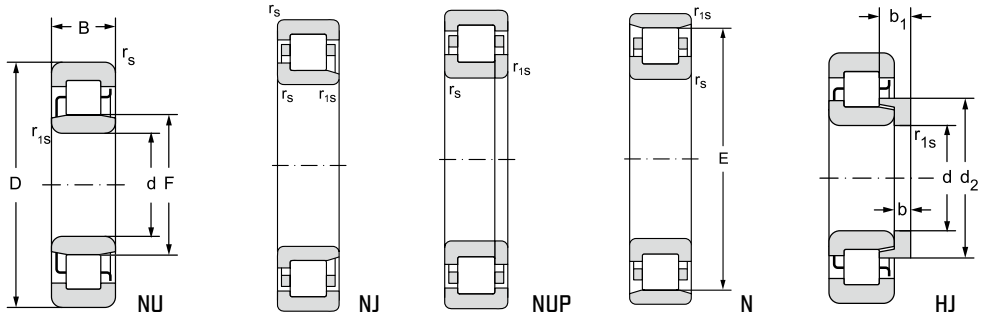

12.4.1

Main dimensions											Bearing designation	Other cages	Angle ring designation	Basic load rating		
d	D	B	r _s	r _{1s}	F	E	d ₂	b	b ₁	s ₁				C _r	C _{or}	
			min	min			max				kN					
55	100	21,00	1,5	1,1	66,5		71,5	6,0	11,00	1,6	NU211		HJ211	56,2	56,2	
	100	21,00	1,5	1,1	66,5		71,5	6,0	11,00	1,6	NJ211		HJ211	56,2	56,2	
	100	21,00	1,5	1,1	66,5					1,6	NUP211			56,2	56,2	
	100	21,00	1,5	1,1		88,5					1,6	N211			56,2	56,2
	100	21,00	1,5	1,1	66		71,0	6,0	9,50	1,6	NU211E		HJ211E	85,8	90,9	
	100	21,00	1,5	1,1	66		71,0	6,0	9,50	1,6	NJ211E		HJ211E	85,8	90,9	
	100	21,00	1,5	1,1	66						1,6	NUP211E			85,8	90,9
	100	25,00	1,5	1,1	66,5						1,6	NU2211			76,4	82,5
	100	25,00	1,5	1,1	66,5						1,6	NJ2211			76,4	82,5
	100	25,00	1,5	1,1	66,5						1,6	NUP2211			76,4	82,5
	100	33,34	1,5	2,1	66,9						4,5	NU5211M			119,0	171,0
	120	29,00	2,0	2,0	70,5		78,4	9,0	15,00	1,5	NU311		HJ311	108,0	100,0	
		29,00	2,0	2,0	70,5		78,4	9,0	15,00	1,5	NJ311		HJ311	108,0	100,0	
		29,00	2,0	2,0	70,5						1,5	NUP311			108,0	100,0
		29,00	2,0	2,0		104,5					1,5	N311			108,0	100,0
		29,00	2,0	2,0	70,5		77,7	9,0	14,00	1,5	NU311E		HJ311E	136,0	128,0	
29,00		2,0	2,0	70,5		77,7	9,0	14,00	1,5	NJ311E		HJ311E	136,0	128,0		
29,00		2,0	2,0	70,5						1,5	NUP311E			136,0	128,0	
140		33,00	2,1	2,1	77,2		86,4	10,0	16,60	3,0	NU411		HJ411	139,0	128,0	
140		33,00	2,1	2,1	77,2		86,4	10,0	16,60	3,0	NJ411		HJ411	139,0	128,0	
140		33,00	2,1	2,1	77,2					3,0	NUP411			139,0	128,0	
140	33,00	2,1	2,1		117,2				3,0	N411			139,0	128,0		

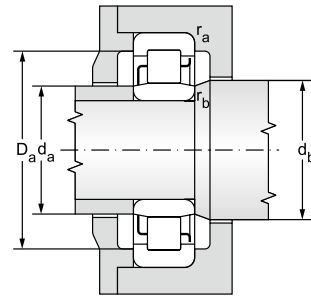
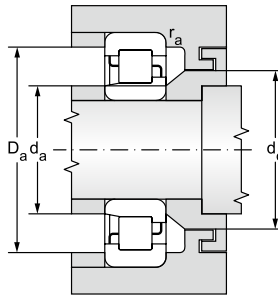
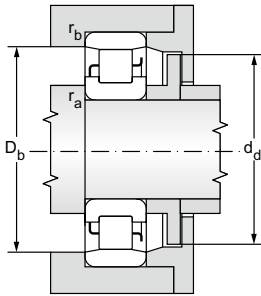

¹⁾ Admissible axial movement

Fatigue load limit	Limiting speed for lubrication with		Abutment and fillet dimensions										Weight		
	P_u	grease	oil	d	d_a	d_a	d_b	d_c	d_d	D_a	D_b	r_a	r_b	~	Ang.r.
kN	min^{-1}			min	max	min	min	max	max	min	max	max	max	of bearing	
6,85	6300	7500		mm										kg	
6,85	6300	7500	55	62	65,0	68,0	73	-	91	-	1,5	1,0	0,64	0,080	
6,85	6300	7500		62	65,0	68,0	73	-	91	-	1,5	1,0	0,64	0,080	
6,85	6300	7500		62	65,0	68,0	73	86	91	91	1,5	1,0	0,64		
11,09	6300	7500		62	64,5	68,0	73	-	91	-	1,5	1,0	0,66	0,080	
11,09	6300	7500		62	64,5	68,0	73	-	91	-	1,5	1,0	0,66	0,080	
11,09	6300	7500		62	64,5	68,0	73	-	91	-	1,5	1,0	0,66		
10,06	6300	7500		62	65,0	68,0	73	-	91	-	1,5	1,0	0,78		
10,06	6300	7500		62	65,0	68,0	73	-	91	-	1,5	1,0	0,78		
10,06	6300	7500		62	65,0	68,0	73	-	91	-	1,5	1,0	0,78		
20,85	5600	6700		64	-	69,0	-	-	90	-	2,0	1,5	1,20		
12,20	5300	6300		65	67,0	72,0	80	-	110	-	2,0	2,0	1,45	0,19	
12,20	5300	6300		65	67,0	72,0	80	-	110	-	2,0	2,0	1,45	0,19	
12,20	5300	6300		65	67,0	72,0	80	-	110	-	2,0	2,0	1,45		
12,20	5300	6300		65	67,0	72,0	80	102	110	108	2,0	2,0	1,45		
15,61	4700	5600		65	67,0	72,0	80	-	110	-	2,0	2,0	1,38	0,18	
15,61	4700	5600		65	67,0	72,0	80	-	110	-	2,0	2,0	1,38	0,18	
15,61	4700	5600		65	67,0	72,0	80	-	110	-	2,0	2,0	1,38		
15,61	4500	5300		68	71,0	79,0	88	-	126	-	2,0	2,0	2,50	0,30	
15,61	4500	5300		68	71,0	79,0	88	-	126	-	2,0	2,0	2,50	0,30	
15,61	4500	5300		68	71,0	79,0	88	-	126	-	2,0	2,0	2,50		
15,61	4500	5300		68	71,0	79,0	88	115	126	120	2,0	2,0	2,50		

Single row cylindrical roller bearings

d = 60 to 65 mm

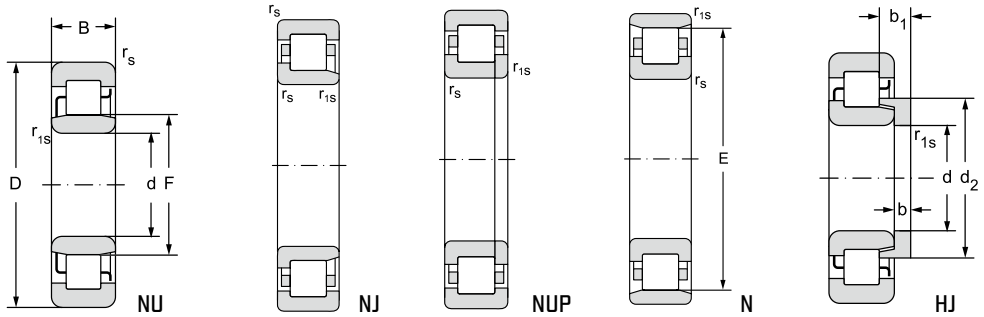

12.4.1

Main dimensions											Bearing designation	Other cages	Angle ring designation	Basic load rating		
d	D	B	r _s	r _{1s}	F	E	d ₂	b	b ₁	s ₁				C _r	C _{or}	
			min	min				max				kN				
60	110	22,00	1,5	1,5	73,5		79,0	6,0	11,00	1,6		NU212		HJ212	66,8	68,1
	110	22,00	1,5	1,5	73,5		79,0	6,0	11,00	1,6		NJ212		HJ212	66,8	68,1
	110	22,00	1,5	1,5	73,5					1,6		NUP212			66,8	68,1
	110	22,00	1,5	1,5		97,5				1,6		N212			66,8	68,1
	110	28,00	1,5	1,5	73,5					1,6		NU2212			98,1	112,0
	110	28,00	1,5	1,5	73,5					1,6		NJ2212			98,1	112,0
	110	28,00	1,5	1,5	73,5					1,6		NUP2212			98,1	112,0
	110	36,50	1,5	2,0	72,38					4,5		NU5212M			150,0	211,0
	130	31,00	2,1	2,1	77		85,3	9,0	15,50	1,5		NU312		HJ312	121,0	114,0
	130	31,00	2,1	2,1	77		85,3	9,0	15,50	1,5		NJ312		HJ312	121,0	114,0
	130	31,00	2,1	2,1	77					1,5		NUP312			121,0	114,0
	130	31,00	2,1	2,1		113,0				1,5		N312			121,0	114,0
	130	46,00	2,1	2,1	77					4,5		NU2312			168,0	174,0
	130	46,00	2,1	2,1	77					4,5		NJ2312			168,0	174,0
	130	46,00	2,1	2,1	77					4,5		NUP2312			168,0	174,0
	150	35,00	2,1	2,1	83		93,1	10,0	16,50	2,0		NU412		HJ412	168,0	158,0
150	35,00	2,1	2,1	83		93,1	10,0	16,50	2,0		NJ412		HJ412	168,0	158,0	
150	35,00	2,1	2,1	83					2,0		NUP412			168,0	158,0	
150	35,00	2,1	2,1		127,0				2,0		N412			168,0	158,0	
65	120	23,00	1,5	1,5	79,6		85,6	6,0	11,00	1,6		NU213		HJ213	79,4	82,5
	120	23,00	1,5	1,5	79,6		85,6	6,0	11,00	1,6		NJ213		HJ213	79,4	82,5
	120	23,00	1,5	1,5	79,6					1,6		NUP213			79,4	82,5
	120	23,00	1,5	1,5		105,6				1,6		N213			79,4	82,5
	120	31,00	1,5	1,5	79,6					1,6		NU2213			117,0	136,0
	120	31,00	1,5	1,5	79,6					1,6		NJ2213			117,0	136,0
	120	31,00	1,5	1,5	79,6					1,6		NUP2213			117,0	136,0
	120	38,10	1,7	1,7	80,42					4,5		NU5213M			139,0	196,0
	140	33,00	2,1	2,1	83,5		92,2	10,0	17,00	1,5		NU313		HJ313	131,0	128,0
	140	33,00	2,1	2,1	83,5		92,2	10,0	17,00	1,5		NJ313		HJ313	131,0	128,0
	140	33,00	2,1	2,1	83,5					1,5		NUP313			131,0	128,0
	140	33,00	2,1	2,1		121,5				1,5		N313			131,0	128,0
	140	33,00	2,1	2,1	82,5		90,7	10,0	15,50	1,5		NU313E		HJ313E	181,0	178,0
	140	33,00	2,1	2,1	82,5		90,7	10,0	15,50	1,5		NJ313E		HJ313E	181,0	178,0
	140	33,00	2,1	2,1	82,5					1,5		NUP313E			181,0	178,0
	140	48,00	2,1	2,1	83,5					4,5		NU2313			192,0	203,0
	140	48,00	2,1	2,1	83,5					4,5		NJ2313			192,0	203,0
	140	48,00	2,1	2,1	83,5					4,5		NUP2313			192,0	203,0
	160	37,00	2,1	2,1	89,3		99,9	11,0	18,00	2,0		NU413MAS	M	HJ413	181,0	174,0
	160	37,00	2,1	2,1	89,3		99,9	11,0	18,00	2,0		NJ413MAS	M	HJ413	181,0	174,0
160	37,00	2,1	2,1	89,3					2,0		NUP413MAS	M		181,0	174,0	

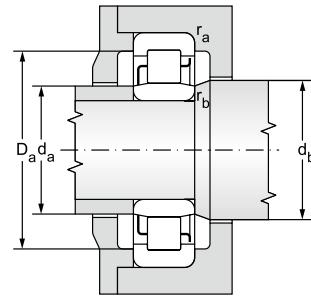
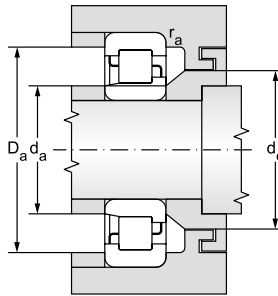
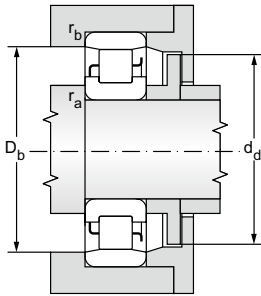

¹⁾ Admissible axial movement

Fatigue load limit	Limiting speed for lubrication with		Abutment and fillet dimensions										Weight		
	P_u	grease	oil	d	d_a	d_a	d_b	d_c	d_d	D_a	D_b	r_a	r_b	~	Ang.r.
kN	min^{-1}			min	max	min	min	max	max	min	max	max	max	of bearing	
				mm										kg	
8,30	5600	6700	60	67	71,0	75,0	80	-	101	-	1,5	1,5	0,82	0,11	
8,30	5600	6700		67	71,0	75,0	80	-	101	-	1,5	1,5	0,82	0,11	
8,30	5600	6700		67	71,0	75,0	80	-	101	-	1,5	1,5	0,82		
8,30	5600	6700		67	71,0	75,0	80	95	101	101	1,5	1,5	0,82		
13,66	5600	6700		69	69,5	74,0	79	-	101	-	1,5	1,5	1,05		
13,66	5600	6700		69	69,5	74,0	79	-	101	-	1,5	1,5	1,05		
13,66	5600	6700		69	69,5	74,0	79	-	101	-	1,5	1,5	1,05		
25,73	5300	6300		69	-	74,0	-	-	99	-	2,0	1,5	1,59		
13,90	4700	5600		72	75,0	79,0	87	-	118	-	2,0	2,0	1,85	0,22	
13,90	4700	5600		72	75,0	79,0	87	-	118	-	2,0	2,0	1,85	0,22	
13,90	4700	5600		72	75,0	79,0	87	-	118	-	2,0	2,0	1,85		
13,90	4700	5600		72	75,0	79,0	87	110	118	117	2,0	2,0	1,85		
21,22	4700	5600		72	75,0	79,0	87	-	118	-	2,0	2,0	2,70		
21,22	4700	5600		72	75,0	79,0	87	-	118	-	2,0	2,0	2,70		
21,22	4700	5600		72	75,0	79,0	87	-	118	-	2,0	2,0	2,70		
18,99	4200	5000		73	77,0	85,0	95	-	136	-	2,0	2,0	3,00	0,34	
18,99	4200	5000		73	77,0	85,0	95	-	136	-	2,0	2,0	3,00	0,34	
18,99	4200	5000		73	77,0	85,0	95	-	136	-	2,0	2,0	3,00		
18,99	4200	5000		73	77,0	85,0	95	124	136	130	2,0	2,0	3,00		
10,06	5300	6300	65	72	77,0	81,0	87	-	111	-	1,5	1,5	1,05	0,13	
10,06	5300	6300		72	77,0	81,0	87	-	111	-	1,5	1,5	1,05	0,13	
10,06	5300	6300		72	77,0	81,0	87	-	111	-	1,5	1,5	1,05		
10,06	5300	6300		72	77,0	81,0	87	103	111	110	1,5	1,5	1,05		
16,59	5300	6300		72	77,0	81,0	87	-	111	-	1,5	1,5	1,45		
16,59	5300	6300		72	77,0	81,0	87	-	111	-	1,5	1,5	1,45		
16,59	5300	6300		72	77,0	81,0	87	-	111	-	1,5	1,5	1,45		
23,90	4700	5600		77	-	83,0	-	-	108	-	1,5	1,5	1,88		
15,49	4500	5300		76	78,0	85,0	94	-	128	-	2,0	2,0	2,25	0,29	
15,49	4500	5300		76	78,0	85,0	94	-	128	-	2,0	2,0	2,25	0,29	
15,49	4500	5300		76	78,0	85,0	94	-	128	-	2,0	2,0	2,25		
15,49	4500	5300		76	78,0	85,0	94	119	128	126	2,0	2,0	2,25		
21,55	4200	5000		76	77,0	84,0	93	-	128	-	2,0	2,0	2,35	0,27	
21,55	4200	5000		76	77,0	84,0	93	-	128	-	2,0	2,0	2,35	0,27	
21,55	4200	5000		76	77,0	84,0	93	-	128	-	2,0	2,0	2,35		
24,57	4500	5300		76	78,0	85,0	94	-	128	-	2,0	2,0	3,25		
24,57	4500	5300		76	78,0	85,0	94	-	128	-	2,0	2,0	3,25		
24,57	4500	5300		76	78,0	85,0	94	-	128	-	2,0	2,0	3,25		
20,48	3800	4500		78	83,0	91,0	101	-	146	-	2,0	2,0	3,60	0,43	
20,48	3800	4500		78	83,0	91,0	101	-	146	-	2,0	2,0	3,60	0,43	
20,48	3800	4500		78	83,0	91,0	101	-	146	-	2,0	2,0	3,60		

Single row cylindrical roller bearings

d = 70 mm

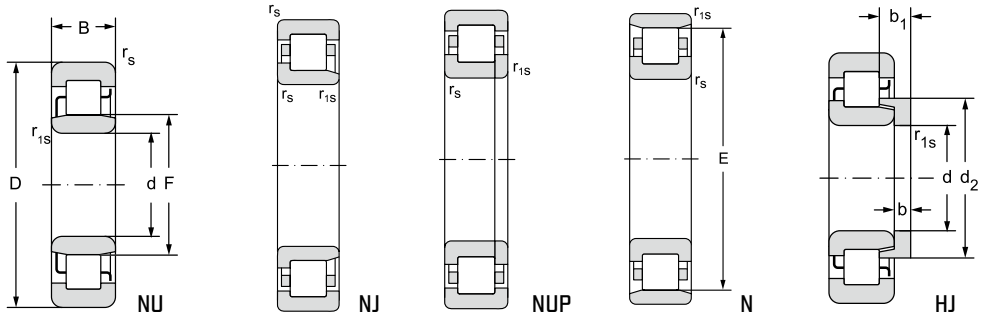

Main dimensions											Bearing designation	Other cages	Angle ring designation	Basic load rating		
d	D	B	r _s	r _{1s}	F	E	d ₂	b	b ₁	s ₁				C _r	C _{or}	
			min	min				max				kN				
70	125	24,00	1,5	1,5	84,5		90,5	7,0	12,50	1,6		NU214		HJ214	79,4	82,5
	125	24,00	1,5	1,5	84,5		90,5	7,0	12,50	1,6		NJ214		HJ214	79,4	82,5
	125	24,00	1,5	1,5	84,5					1,6		NUP214			79,4	82,5
	125	24,00	1,5	1,5		110,5				1,6		N214			79,4	82,5
	125	31,00	1,5	1,5	84,5					1,6		NU2214			117,0	139,0
	125	31,00	1,5	1,5	84,5					1,6		NJ2214			117,0	139,0
	125	31,00	1,5	1,5	84,5					1,6		NUP2214			117,0	139,0
	125	39,69	1,5	2,2	84,84					4,5		NU5214M			178,0	261,0
	150	35,00	2,1	2,1	90		99,2	10,0	17,50	1,5		NU314		HJ314	147,0	144,0
	150	35,00	2,1	2,1	90		99,2	10,0	17,50	1,5		NJ314		HJ314	147,0	144,0
	150	35,00	2,1	2,1	90					1,5		NUP314			147,0	144,0
	150	35,00	2,1	2,1		130,0				1,5		N314			147,0	144,0
	150	51,00	2,1	2,1	90					4,1		NU2314			215,0	233,0
	150	51,00	2,1	2,1	90					4,1		NJ2314			215,0	233,0
	150	51,00	2,1	2,1	90					4,1		NUP2314			215,0	233,0
	150	51,00	2,1	2,1	89					4,1		NU2314EMAS			282,0	310,0
	150	51,00	2,1	2,1	89					4,1		NJ2314EMAS			282,0	310,0
	150	51,00	2,1	2,1	89					4,1		NUP2314EMAS			282,0	310,0
	180	42,00	3,0	3,0	100		112,0	12,0	20,00	2,0		NU414		HJ414	224,0	215,0
	180	42,00	3,0	3,0	100		112,0	12,0	20,00	2,0		NJ414		HJ414	224,0	215,0
	180	42,00	3,0	3,0	100					2,0		NUP414			224,0	215,0
	180	42,00	3,0	3,0		152,0				2,0		N414			224,0	215,0

12.4.1

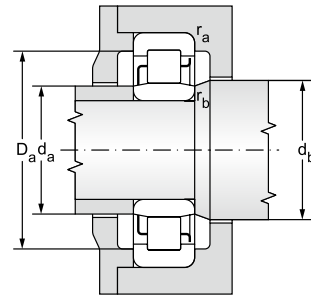
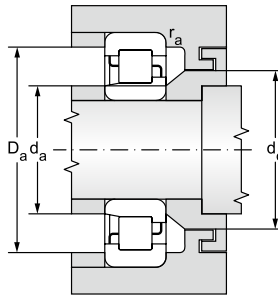
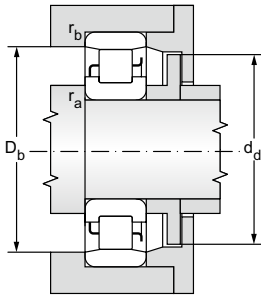

¹⁾ Admissible axial movement

Fatigue load limit	Limiting speed for lubrication with		Abutment and fillet dimensions										Weight		
	P_u	grease	oil	d	d_a	d_a	d_b	d_c	d_d	D_a	D_b	r_a	r_b	~	Ang.r.
kN	min^{-1}			min	max	min	min	max	max	min	max	max	max	of bearing	
10,06	5600	6700		70	77	82,0	86,0	92	-	116	-	1,5	1,5	1,15	0,16
10,06	5600	6700			77	82,0	86,0	92	-	116	-	1,5	1,5	1,15	0,16
10,06	5600	6700			77	82,0	86,0	92	-	116	-	1,5	1,5	1,15	
10,06	5600	6700			77	82,0	86,0	92	108	116	115	1,5	1,5	1,15	
16,95	5000	6000			77	82,0	86,0	92	-	116	-	1,5	1,5	1,50	
16,95	5000	6000			77	82,0	86,0	92	-	116	-	1,5	1,5	1,50	
16,95	5000	6000			77	82,0	86,0	92	-	116	-	1,5	1,5	1,50	
31,83	4700	5600			81,5	-	87,0	-	-	112	-	2,0	1,5	2,22	
17,07	4200	5000			81	85,0	92,0	101	-	138	-	2,0	2,0	2,75	0,34
19,14	4200	5000			81	85,0	92,0	101	-	138	-	2,0	2,0	2,75	0,34
19,14	4200	5000			81	85,0	92,0	101	-	138	-	2,0	2,0	2,75	
19,14	4200	5000			81	85,0	92,0	101	127	138	135	2,0	2,0	2,75	
27,61	4200	5000			81	85,0	92,0	101	-	138	-	2,0	2,0	5,25	
27,61	4200	5000			81	85,0	92,0	101	-	138	-	2,0	2,0	5,25	
27,61	4200	5000			81	85,0	92,0	101	-	138	-	2,0	2,0	5,25	
36,74	3800	4500			81	84,0	91,0	100	-	138	-	2,0	2,0	4,21	
36,74	3800	4500			81	84,0	91,0	100	-	138	-	2,0	2,0	4,21	
36,74	3800	4500			81	84,0	91,0	100	-	138	-	2,0	2,0	4,21	
24,52	3300	4000			85	93,0	102,0	114	-	164	-	2,5	2,5	5,25	0,61
24,52	3300	4000			85	93,0	102,0	114	-	164	-	2,5	2,5	5,25	0,61
24,52	3300	4000			85	93,0	102,0	114	-	164	-	2,5	2,5	5,25	
24,52	3300	4000			85	93,0	102,0	114	149	164	156	2,5	2,5	5,25	

Single row cylindrical roller bearings

d = 75 mm

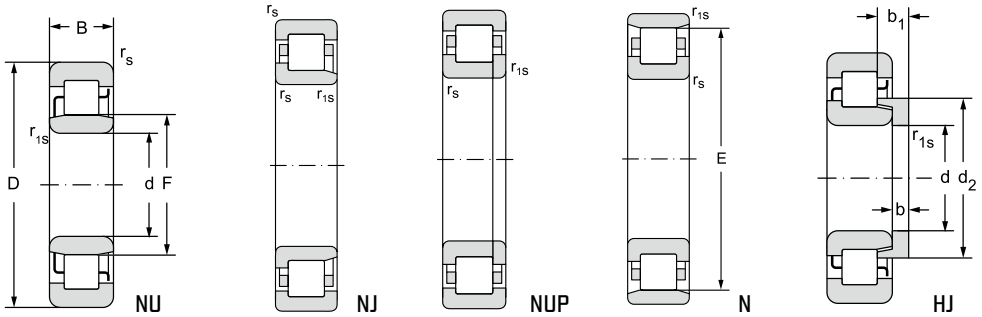

12.4.1

Main dimensions											Bearing designation	Other cages	Angle ring designation	Basic load rating	
d	D	B	r _s	r _{1s}	F	E	d ₂	b	b ₁	s ₁				C _r	C _{or}
			min	min				max				kN			
75	130	25,00	1,5	1,5	88,5		94,9	7,0	12,50	1,6	NU215		HJ215	96,2	96,2
	130	25,00	1,5	1,5	88,5		94,9	7,0	12,50	1,6	NJ215		HJ215	96,2	96,2
	130	25,00	1,5	1,5	88,5					1,6	NUP215			96,2	96,2
	130	25,00	1,5	1,5		116,5				1,6	N215			96,2	96,2
	130	25,00	1,5	1,5	88,5		94,6	7,0	11,00	1,6	NU215E		HJ215E	131,0	147,0
	130	25,00	1,5	1,5	88,5		94,6	7,0	11,00	1,6	NJ215E		HJ215E	131,0	147,0
	130	25,00	1,5	1,5	88,5					1,6	NUP215E			131,0	147,0
	130	31,00	1,5	1,5	88,5					2,1	NU2215E			162,0	196,0
	130	31,00	1,5	1,5	88,5					2,1	NJ2215E			162,0	196,0
	130	31,00	1,5	1,5	88,5					2,1	NUP2215E			162,0	196,0
	130	41,28	1,5	1,5	89,014					4,5	NU5215M			196,0	299,0
	160	37,00	2,1	2,1	95,5		105,6	11,0	18,50	1,5	NU315		HJ315	178,0	178,0
	160	37,00	2,1	2,1	95,5		105,6	11,0	18,50	1,5	NJ315		HJ315	178,0	178,0
	160	37,00	2,1	2,1	95,5					1,5	NUP315			178,0	178,0
	160	37,00	2,1	2,1		139,5				1,5	N315			178,0	178,0
	160	55,00	2,1	2,1	95,5					4,5	NU2315			266,0	287,0
	160	55,00	2,1	2,1	95,5					4,5	NJ2315			266,0	287,0
	160	55,00	2,1	2,1	95,5					4,5	NUP2315			266,0	287,0
	190	45,00	3,0	2,0	104,5		117,0	13,0	21,50	2,0	NU415		HJ415	261,0	251,0
	190	45,00	3,0	2,0	104,5		117,0	13,0	21,50	2,0	NU415		HJ415	261,0	251,0
	190	45,00	3,0	2,0	104,5					2,0	NUP415			261,0	251,0
	190	45,00	3,0	2,0		160,5				2,0	N415			261,0	251,0

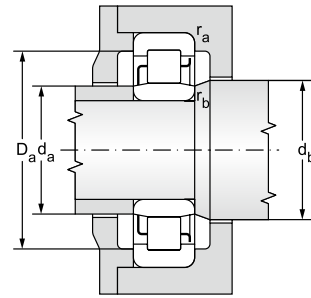
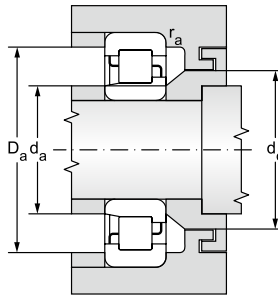
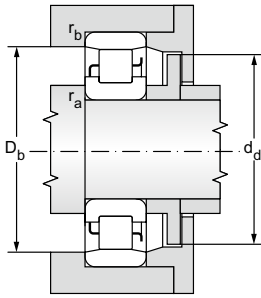

¹⁾ Admissible axial movement

Fatigue load limit	Limiting speed for lubrication with		Abutment and fillet dimensions										Weight	
	P_u	grease	oil	d	d_a	d_a	d_b	d_c	d_d	D_a	D_b	r_a	r_b	~
kN	min^{-1}			min	max	min	min	max	max	min	max	max	of bearing	
11,65	4700	5600	75	82	85,0	90,0	96	-	121	-	1,5	1,5	1,25	0,17
11,65	4700	5600		82	85,0	90,0	96	-	121	-	1,5	1,5	1,25	0,17
11,65	4700	5600		82	85,0	90,0	96	114	121	120	1,5	1,5	1,25	
11,65	4700	5600		82	85,0	90,0	96	-	121	-	1,5	1,5	1,25	
17,79	4500	5300		82	85,0	90,0	96	-	121	-	1,5	1,5	1,30	0,16
17,79	4500	5300		82	85,0	90,0	96	-	121	-	1,5	1,5	1,30	0,16
17,79	4500	5300		82	85,0	90,0	96	-	121	-	1,5	1,5	1,30	
23,73	4500	5300		82	85,0	90,0	96	-	121	-	1,5	1,5	1,65	
23,73	4500	5300		82	85,0	90,0	96	-	121	-	1,5	1,5	1,65	
23,73	4500	5300		82	85,0	90,0	96	-	121	-	1,5	1,5	1,65	
36,19	4500	5300		85,5	-	91,0	-	-	117	-	2,0	1,5	2,41	
20,68	3800	4500		86	93,0	97,0	107	-	148	-	2,0	2,0	3,25	0,40
20,68	3800	4500		86	93,0	97,0	107	-	148	-	2,0	2,0	3,25	0,40
20,68	3800	4500		86	93,0	97,0	107	-	148	-	2,0	2,0	3,25	
20,68	3800	4500		86	93,0	97,0	107	137	148	145	2,0	2,0	3,25	
33,35	3800	4500		86	93,0	97,0	107	-	148	-	2,0	2,0	4,85	
33,35	3800	4500		86	93,0	97,0	107	-	148	-	2,0	2,0	4,85	
33,35	3800	4500		86	93,0	97,0	107	-	148	-	2,0	2,0	4,85	
28,13	3200	3800		90	98,0	107,0	119	-	174	-	2,5	2,5	6,25	0,80
28,13	3200	3800		90	98,0	107,0	119	-	174	-	2,5	2,5	6,25	0,80
28,13	3200	3800		90	98,0	107,0	119	-	174	-	2,5	2,5	6,25	
28,13	3200	3800		90	98,0	107,0	119	158	174	164	2,5	2,5	6,25	

Single row cylindrical roller bearings

d = 80 to 85 mm

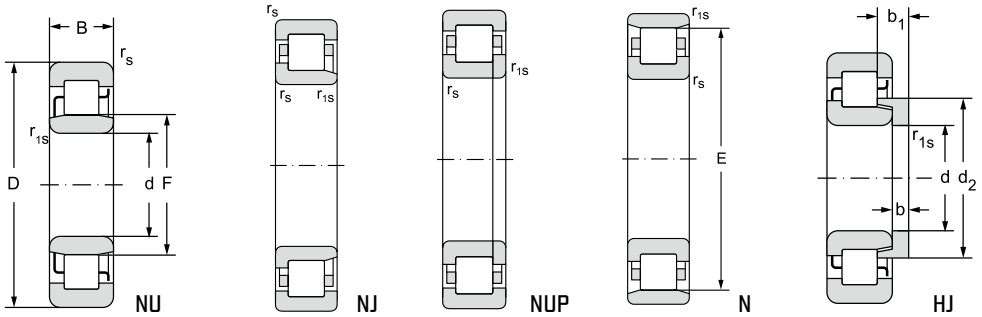

Main dimensions											Bearing designation	Other cages	Angle ring designation	Basic load rating			
d	D	B	r _s	r _{1s}	F	E	d ₂	b	b ₁	s ₁				C _r	C _{or}		
			min	min				max				kN					
80	125	22,00	1,1	1,0	91,5						1,2	NU1016			66,8	76,4	
	140	26,00	2,0	2,0	95,3		102,2	8,0	13,50	2,0		NU216	HJ216		106,0	114,0	
	140	26,00	2,0	2,0	95,3		102,2	8,0	13,50	2,0		NJ216	HJ216		106,0	114,0	
	140	26,00	2,0	2,0	95,3					2,0		NUP216			106,0	114,0	
	140	26,00	2,0	2,0		125,3				2,0		N216			106,0	114,0	
	140	33,00	2,0	2,0	95,3					2,5		NU2216			147,0	178,0	
	140	33,00	2,0	2,0	95,3					2,5		NJ2216			147,0	178,0	
	140	33,00	2,0	2,0	95,3					2,5		NUP2216			147,0	178,0	
	140	33,00	2,0	2,0	95,3					2,5		NU2216E			196,0	246,0	
	140	33,00	2,0	2,0	95,3					2,5		NJ2216E			196,0	246,0	
	140	33,00	2,0	2,0	95,3					2,5		NUP2216E			196,0	246,0	
	140	44,45	2,1	2,1	95,28					5,0		NU5216M			185,0	282,0	
	170	39,00	2,1	2,1	103			113,1	11,0	19,50	1,5		NU316	HJ316		192,0	192,0
	170	39,00	2,1	2,1	103			113,1	11,0	19,50	1,5		NJ316	HJ316		192,0	192,0
	170	39,00	2,1	2,1	103						1,5		NUP316			192,0	192,0
	170	39,00	2,1	2,1		147,0					1,5		N316			192,0	192,0
200	48,00	3,0	3,0	110			123,8	13,0	22,00	2,0		NU416M	HJ416		299,0	293,0	
200	48,00	3,0	3,0	110			123,8	13,0	22,00	2,0		NJ416M	HJ416		299,0	293,0	
200	48,00	3,0	3,0	110						2,0		NUP416M			299,0	293,0	
200	48,00	3,0	3,0		170,0					2,0		N416M			299,0	293,0	
85	150	28,00	2,0	2,0	101,8		109,2	8,0	14,00	2,0		NU217	HJ217		121,0	131,0	
	150	28,00	2,0	2,0	101,8		109,2	8,0	14,00	2,0		NJ217	HJ217		121,0	131,0	
	150	28,00	2,0	2,0	101,8					2,0		NUP217			121,0	131,0	
	150	28,00	2,0	2,0		133,8				2,0		N217			121,0	131,0	
	150	36,00	2,0	2,0	100,5					2,0		NU2217E			220,0	261,0	
	150	36,00	2,0	2,0	100,5					2,0		NJ2217E			220,0	261,0	
	150	36,00	2,0	2,0	100,5					2,0		NUP2217E			220,0	261,0	
	150	49,21	2,1	2,1	102					5,5		NU5217M			211,0	316,0	
	180	41,00	3,0	3,0	108			119,0	12,0	20,50	2,0		NU317	HJ317		215,0	215,0
	180	41,00	3,0	3,0	108			119,0	12,0	20,50	2,0		NJ317	HJ317		215,0	215,0
	180	41,00	3,0	3,0	108						2,0		NUP317			215,0	215,0
	180	41,00	3,0	3,0		156,0					2,0		N317			215,0	215,0
	210	52,00	4,0	4,0	113			127,7	14,0	24,00	2,5		NU417M	MAS	HJ417	362,0	362,0
	210	52,00	4,0	4,0	113			127,7	14,0	24,00	2,5		NJ417M	MAS	HJ417	362,0	362,0
	210	52,00	4,0	4,0	113						2,5		NUP417			362,0	362,0

12.4.1

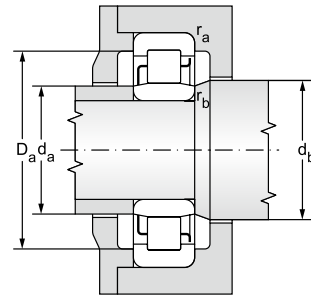
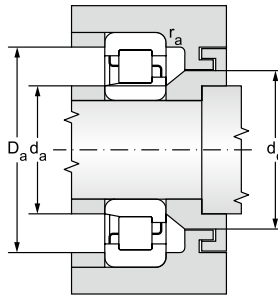
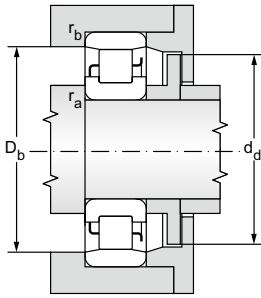

¹⁾ Admissible axial movement



Fatigue load limit	Limiting speed for lubrication with		Abutment and fillet dimensions										Weight		
	P_u	grease	oil	d	d_a	d_a	d_b	d_c	d_d	D_a	D_b	r_a	r_b	~	Ang.r.
kN	min^{-1}			min	max	min	min	max	max	min	max	max	max	of bearing	
9,25	5000	6000	80	85	90,0	94,0	-	-	118	-	-	1,0	1,0	0,99	
13,51	4500	5300		90	92,0	97,0	104	-	130	-	2,0	2,0	1,50	0,21	
13,51	4500	5300		90	92,0	97,0	104	-	130	-	2,0	2,0	1,50	0,21	
13,51	4500	5300		90	92,0	97,0	104	-	130	-	2,0	2,0	1,50		
13,51	4500	5300		90	92,0	97,0	104	125	130	130	2,0	2,0	1,50		
21,10	4500	5300		90	92,0	97,0	104	-	130	-	2,0	2,0	1,95		
21,10	4500	5300		90	92,0	97,0	104	-	130	-	2,0	2,0	1,95		
21,10	4500	5300		90	92,0	97,0	104	-	130	-	2,0	2,0	1,95		
29,15	4200	5000		90	92,0	97,0	104	-	130	-	2,0	2,0	2,05		
29,15	4200	5000		90	92,0	97,0	104	-	130	-	2,0	2,0	2,05		
29,15	4200	5000		90	92,0	97,0	104	-	130	-	2,0	2,0	2,05		
33,42	4200	5000		91,5	-	98,0	-	-	126	-	2,0	2,0	2,91		
21,90	3500	4200		99	97,0	105,0	116	-	158	-	2,0	2,0	3,90	0,49	
21,90	3500	4200		99	97,0	105,0	116	-	158	-	2,0	2,0	3,90	0,49	
21,90	3500	4200		99	97,0	105,0	116	-	158	-	2,0	2,0	3,90		
21,90	3500	4200		99	97,0	105,0	116	144	158	153	2,0	2,0	3,90		
32,30	3000	3500		95	105,0	112,0	125	-	184	-	2,5	2,5	7,30	0,80	
32,30	3000	3500		95	105,0	112,0	125	-	184	-	2,5	2,5	7,30	0,80	
32,30	3000	3500		95	105,0	112,0	125	-	184	-	2,5	2,5	7,30		
32,30	3000	3500		95	105,0	112,0	125	167	184	174	2,5	2,5	7,30		
15,22	4200	5000	85	95	99,0	104,0	111	-	140	-	2,0	2,0	1,90	0,25	
15,22	4200	5000		95	99,0	104,0	111	-	140	-	2,0	2,0	1,90	0,25	
15,22	4200	5000		95	99,0	104,0	111	-	140	-	2,0	2,0	1,90	0,25	
15,22	4200	5000		95	99,0	104,0	111	131	140	138	2,0	2,0	1,90	0,25	
30,33	3800	4500		95	98,0	103,0	110	-	140	-	2,0	2,0	2,52		
30,33	3800	4500		95	98,0	103,0	110	-	140	-	2,0	2,0	2,52		
30,33	3800	4500		95	98,0	103,0	110	-	140	-	2,0	2,0	2,52		
36,72	3800	4500		98	-	105,0	-	-	135	-	2,0	2,0	3,69		
24,10	3300	4000		98	103,0	110,0	121	174	166	162	2,5	2,5	4,50	0,57	
24,10	3300	4000		98	103,0	110,0	121	174	166	162	2,5	2,5	4,50	0,57	
24,10	3300	4000		98	103,0	110,0	121	174	166	162	2,5	2,5	4,50		
24,10	3300	4000		98	103,0	110,0	121	174	166	162	2,5	2,5	4,50		
39,29	3000	3500		105	108,0	115,0	129	-	190	-	3,0	3,0	8,70	0,89	
39,29	3000	3500		105	108,0	115,0	129	-	190	-	3,0	3,0	8,70	0,89	
39,29	3000	3500		105	108,0	115,0	129	-	190	-	3,0	3,0	8,70		

Single row cylindrical roller bearings

d = 90 to 95 mm

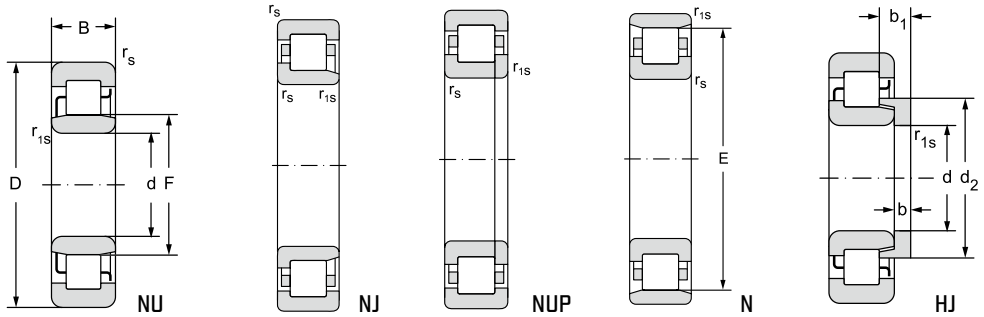

12.4.1

Main dimensions											Bearing designation	Other cages	Angle ring designation	Basic load rating				
d	D	B	r _s	r _{1s}	F	E	d ₂	b	b ₁	s ₁				C _r	C _{or}			
			min	min			max				kN							
90	160	30,00	2,0	2,0	107		115,3	9,0	15,00	2,0			NU218		HJ218	147,0	158,0	
	160	30,00	2,0	2,0	107		115,3	9,0	15,00	2,0			NJ218		HJ218	147,0	158,0	
	160	30,00	2,0	2,0	107					2,0			NUP218			147,0	158,0	
	160	30,00	2,0	2,0		143,0					2,0		N218			147,0	158,0	
	160	40,00	2,0	2,0	107						2,0		NJ2218EM	F		241,0	313,0	
	160	52,40	2,1	3,0	107,218						6,0		NU5218M			237,0	355,0	
	190	43,00	3,0	3,0	115		126,5	12,0	21,00		2,0		NU318		HJ318	233,0	242,0	
	190	43,00	3,0	3,0	115		126,5	12,0	21,00		2,0		NJ318		HJ318	233,0	242,0	
	190	43,00	3,0	3,0	115						2,0		NUP318			233,0	242,0	
	190	43,00	3,0	3,0		165,0					2,0		N318			233,0	242,0	
	190	43,00	3,0	3,0	113,5		124,2	12,0	18,50		2,0		NU318EM		HJ318E	316,0	329,0	
	190	43,00	3,0	3,0	113,5		124,2	12,0	18,50		2,0		NJ318EM		HJ318E	316,0	329,0	
	190	43,00	3,0	3,0	113,5						2,0		NUP318EM			316,0	329,0	
	225	54,00	4,0	4,0	123,5			139,1	14,0	24,00	2,5		NU418M	MAS	HJ418	391,0	406,0	
	225	54,00	4,0	4,0	123,5			139,1	14,0	24,00	2,5		NJ418M	MAS	HJ418	391,0	406,0	
	225	54,00	4,0	4,0	123,5						2,5		NUP418M	MAS		391,0	406,0	
	95	170	32,00	2,1	2,1	113,5		122,2	9,0	15,50	2,0			NU219		HJ219	162,0	181,0
		170	32,00	2,1	2,1	113,5		122,2	9,0	15,50	2,0			NJ219		HJ219	162,0	181,0
170		32,00	2,1	2,1	113,5					2,0			NUP219			162,0	181,0	
170		32,00	2,1	2,1		151,5					2,0		N219			162,0	181,0	
170		43,00	2,1	2,1	113,5					3,0			NU2219			233,0	282,0	
170		43,00	2,1	2,1	113,5					3,0			NJ2219			233,0	282,0	
170		43,00	2,1	2,1	113,5					3,0			NUP2219			233,0	282,0	
170		55,56	2,5	3,0	113,52						6,0		NU5219M			335,0	511,0	
200		45,00	3,0	3,0	121,5						2,0		NU319			256,0	266,0	
200		45,00	3,0	3,0	121,5						2,0		NJ319			256,0	266,0	
200		45,00	3,0	3,0	121,5						2,0		NUP319			256,0	266,0	
200		45,00	3,0	3,0		173,5					2,0		N319			256,0	266,0	
200		45,00	3,0	3,0	121,5						1,9		NU319EM			329,0	362,0	
200		45,00	3,0	3,0	121,5						1,9		NJ319EM			329,0	362,0	
200		45,00	3,0	3,0	121,5						1,9		NUP319EM			329,0	362,0	
240		55,00	4,0	4,0	133,5						2,5		NU419M			430,0	447,0	
240		55,00	4,0	4,0	133,5						2,5		NJ419M			430,0	447,0	
240		55,00	4,0	4,0	133,5						2,5		NUP419M			430,0	447,0	

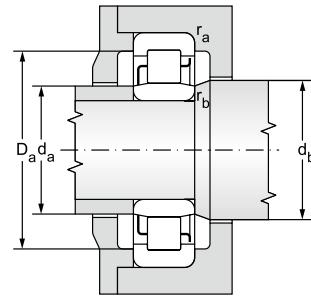
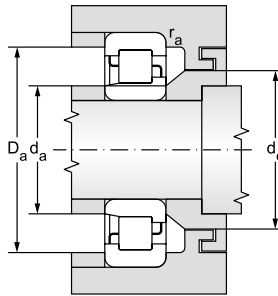
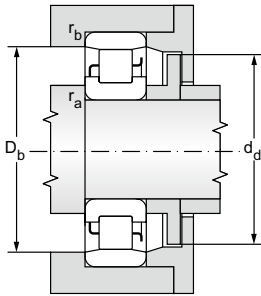

¹⁾ Admissible axial movement



Fatigue load limit	Limiting speed for lubrication with		Abutment and fillet dimensions										Weight		
	P_u	grease	oil	d	d_a	d_a	d_b	d_c	d_d	D_a	D_b	r_a	r_b	~	Ang.r.
kN	min^{-1}			min	max	min	min	max	max	min	max	max	max	of bearing	kg
18,02	4000	4700	90	100	105,0	109,0	117	-	150	-	2,0	2,0		2,30	0,31
18,02	4000	4700		100	105,0	109,0	117	-	150	-	2,0	2,0		2,30	0,31
18,02	4000	4700		100	105,0	109,0	117	140	150	147	2,0	2,0		2,30	
18,02	4000	4700		100	105,0	109,0	117	140	150	147	2,0	2,0		2,30	
35,70	3800	4500		100	105,0	109,0	-	-	150	-	2,0	2,0		3,60	
40,49	3500	4200		103	-	110,0	-	-	144	-	2,5	2,0		4,48	
26,68	3200	3800		103	111,0	117,0	128	-	176	-	2,5	2,5		5,40	0,65
26,68	3200	3800		103	111,0	117,0	128	-	176	-	2,5	2,5		5,40	0,65
26,68	3200	3800		103	111,0	117,0	128	-	176	-	2,5	2,5		5,40	
26,68	3200	3800		103	111,0	117,0	128	162	176	172	2,5	2,5		5,40	
36,27	3000	3500		103	110,0	116,0	127	-	176	-	2,5	2,5		5,50	0,60
36,27	3000	3500		103	110,0	116,0	127	-	176	-	2,5	2,5		5,50	0,60
36,27	3000	3500		103	110,0	116,0	127	-	176	-	2,5	2,5		5,50	
43,20	2700	3200		110	117,0	125,0	140	-	205	-	3,0	3,0		11,7	1,05
43,20	2700	3200		110	117,0	125,0	140	-	205	-	3,0	3,0		11,7	1,05
43,20	2700	3200		110	117,0	125,0	140	-	205	-	3,0	3,0		11,7	
20,29	3800	4500	95	107	111,0	116,0	124	-	158	-	2,0	2,0		2,80	0,35
20,29	3800	4500		107	111,0	116,0	124	-	158	-	2,0	2,0		2,80	0,35
20,29	3800	4500		107	111,0	116,0	124	-	158	-	2,0	2,0		2,80	
20,29	3800	4500		107	111,0	116,0	124	149	158	155	2,0	2,0		2,80	
31,61	3800	4500		107	111,0	116,0	124	-	158	-	2,0	2,0		3,85	
31,61	3800	4500		107	111,0	116,0	124	-	158	-	2,0	2,0		3,85	
31,61	3800	4500		107	111,0	116,0	124	-	158	-	2,0	2,0		3,85	
57,27	3300	4000		110	-	117,0	-	-	153	-	2,5	2,0		5,65	
28,87	3200	3800		109	119,0	124,0	135	-	186	-	2,5	2,5		6,20	
28,87	3200	3800		109	119,0	124,0	135	-	186	-	2,5	2,5		6,20	
28,87	3200	3800		109	119,0	124,0	135	-	186	-	2,5	2,5		6,20	
28,87	3200	3800		109	119,0	124,0	135	170	186	178	2,5	2,5		6,20	
39,29	2800	3300		109	119,0	124,0	135	-	186	-	2,5	2,5		6,50	
39,29	2800	3300		109	119,0	124,0	135	-	186	-	2,5	2,5		6,50	
39,29	2800	3300		109	119,0	124,0	135	-	186	-	2,5	2,5		6,50	
46,70	2500	3000		115	125,0	136,0	151	-	220	-	3,0	3,0		13,5	
46,70	2500	3000		115	125,0	136,0	151	-	220	-	3,0	3,0		13,5	
46,70	2500	3000		115	125,0	136,0	151	-	220	-	3,0	3,0		13,5	

Single row cylindrical roller bearings

d = 100 to 105 mm

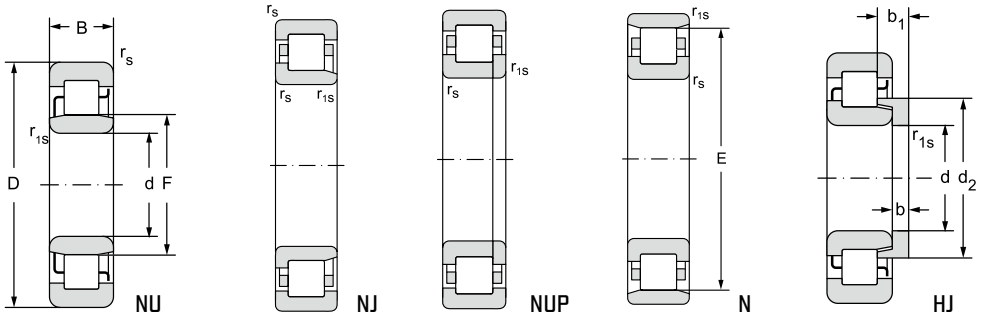

12.4.1

Main dimensions											Bearing designation	Other cages	Angle ring designation	Basic load rating			
d	D	B	r _s	r _{1s}	F	E	d ₂	b	b ₁	s ₁				C _r	C _{or}		
			min	min			max				kN						
100	180	34,00	2,1	2,1	120		129,2	10,0	17,00	2,0		NU220		HJ220	178,0	203,0	
	180	34,00	2,1	2,1	120		129,2	10,0	17,00	2,0		NJ220		HJ220	178,0	203,0	
	180	34,00	2,1	2,1	120					2,0		NUP220			178,0	203,0	
	180	34,00	2,1	2,1		160,0				2,0		N220			178,0	203,0	
	180	46,00	2,1	2,1	120					3,0		NU2220M			261,0	322,0	
	180	46,00	2,1	2,1	120					3,0		NJ2220M			261,0	322,0	
	180	46,00	2,1	2,1	120					3,0		NUP2220M			261,0	322,0	
	180	60,32	2,1	2,1	121,005					7,0		NU5220M			304,0	473,0	
	215	47,00	3,0	3,0	129,5		142,4	13,0	22,50	2,0		NU320		HJ320	299,0	310,0	
	215	47,00	3,0	3,0	129,5		142,4	13,0	22,50	2,0		NJ320		HJ320	299,0	310,0	
	215	47,00	3,0	3,0	129,5					2,0		NUP320			299,0	310,0	
	215	47,00	3,0	3,0		185,5				2,0		N320			299,0	310,0	
	215	73,00	3,0	3,0	127,5					4,9		NU2320EMAS	M		596,0	694,0	
	215	73,00	3,0	3,0	127,5					4,9		NJ2320EMAS	M		596,0	694,0	
215	73,00	3,0	3,0	127,5					4,9		NUP2320EMAS	M		596,0	694,0		
250	58,00	4,0	4,0	139			155,9	16,0	27,00	2,5		NU420M		HJ420	473,0	501,0	
250	58,00	4,0	4,0	139			155,9	16,0	27,00	2,5		NJ420M		HJ420	473,0	501,0	
250	58,00	4,0	4,0	139					2,5		NUP420M			473,0	501,0		
105	190	36,00	2,1	2,1	126,8		136,5	10,0	17,50	2,0		NU221		HJ221	200,0	224,0	
	190	36,00	2,1	2,1	126,8		136,5	10,0	17,50	2,0		NJ221		HJ221	200,0	224,0	
	190	36,00	2,1	2,1	126,8					2,0		NUP221			200,0	224,0	
	190	36,00	2,1	2,1		168,8				2,0		N221			200,0	224,0	
	190	65,10	2,1	2,1	126,52					7,0		NU5221M			362,0	573,0	
	225	49,00	3,0	3,0	135		148,8	13,0	22,50	4,5		NU321		HJ321	341,0	362,0	
	225	49,00	3,0	3,0	135		148,8	13,0	22,50	4,5		NJ321		HJ321	341,0	362,0	
	225	49,00	3,0	3,0	135					4,5		NUP321			341,0	362,0	
	225	49,00	3,0	3,0		195,0				4,5		N321			341,0	362,0	
	260	60,00	4,0	4,0	144,5			162,0	16,0	27,00	2,5		NU421M		HJ421	531,0	562,0
	260	60,00	4,0	4,0	144,5			162,0	16,0	27,00	2,5		NJ421M		HJ421	531,0	562,0
	260	60,00	4,0	4,0	144,5					2,5		NUP421M			531,0	562,0	

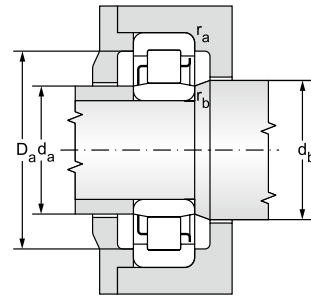
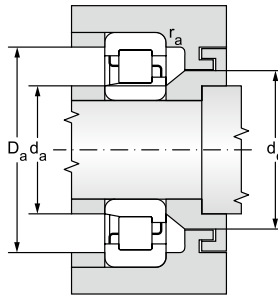
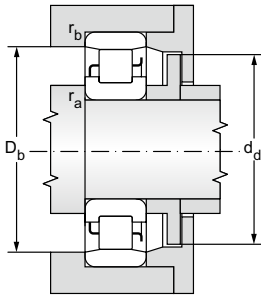

¹⁾ Admissible axial movement



Fatigue load limit	Limiting speed for lubrication with		Abutment and fillet dimensions										Weight		
	P_u	grease	oil	d	d_a	d_a	d_b	d_c	d_d	D_a	D_b	r_a	r_b	~	Ang.r.
kN	min^{-1}			min	max	min	min	max	max	min	max	max	max	of bearing	
22,38	3500	4200	100	112	117,0	122,0	131	-	168	-	2,0	2,0		3,40	0,45
22,38	3500	4200		112	117,0	122,0	131	-	168	-	2,0	2,0		3,40	0,45
22,38	3500	4200		112	117,0	122,0	-	-	168	-	2,0	2,0		3,40	
22,38	3500	4200		112	117,0	122,0	-	157	168	165	2,0	2,0		3,40	
35,50	3500	4200		112	117,0	122,0	-	-	168	-	2,0	2,0		4,65	
35,50	3500	4200		112	117,0	122,0	-	-	168	-	2,0	2,0		4,65	
35,50	3500	4200		112	117,0	122,0	-	-	168	-	2,0	2,0		4,65	
52,14	3200	3800		116,5	-	124,0	-	-	162	-	2,0	2,0		6,49	
32,99	2800	3300		113	125,0	132,0	145	-	201	-	2,0	2,0		7,70	0,91
32,99	2800	3300		113	125,0	132,0	145	-	201	-	2,0	2,0		7,70	0,91
32,99	2800	3300		113	125,0	132,0	-	-	201	-	2,0	2,0		7,70	
32,99	2800	3300		113	125,0	132,0	-	182	201	190	2,0	2,0		7,70	
73,85	2500	3000		113	123,0	130,0	-	-	201	-	2,5	2,5		12,5	
73,85	2500	3000		113	123,0	130,0	-	-	201	-	2,5	2,5		12,5	
73,85	2500	3000		113	123,0	130,0	-	-	201	-	2,5	2,5		12,5	
51,66	2400	2800		120	130,0	141,0	158	-	230	-	3,0	3,0		14,0	1,55
51,66	2400	2800		120	130,0	141,0	158	-	230	-	3,0	3,0		14,0	1,55
51,66	2400	2800		120	130,0	141,0	-	-	230	-	3,0	3,0		14,0	
24,31	3300	4000	105	117	122,0	129,0	138	-	178	-	2,0	2,0		4,00	0,51
24,31	3300	4000		117	122,0	129,0	138	-	178	-	2,0	2,0		4,00	0,51
24,31	3300	4000		117	122,0	129,0	-	-	178	-	2,0	2,0		4,00	
24,31	3300	4000		117	122,0	129,0	-	166	178	175	2,0	2,0		4,00	
62,19	3000	3500		121,5	-	130,0	-	-	171	-	2,0	2,0		7,94	
37,99	2700	3200		119	132,0	137,0	150	-	211	-	2,5	2,5		8,75	1,00
37,99	2700	3200		119	132,0	137,0	150	-	211	-	2,5	2,5		8,75	1,00
37,99	2700	3200		119	132,0	137,0	-	-	211	-	2,5	2,5		8,75	
37,99	2700	3200		119	132,0	137,0	-	192	211	199	2,5	2,5		8,75	
57,22	2200	2700		125	135,0	147,0	164	-	240	-	3,0	3,0		19,0	1,65
57,22	2200	2700		125	135,0	147,0	164	-	240	-	3,0	3,0		19,0	1,65
57,22	2200	2700		125	135,0	147,0	-	-	240	-	3,0	3,0		19,0	

Single row cylindrical roller bearings

d = 110 to 120 mm

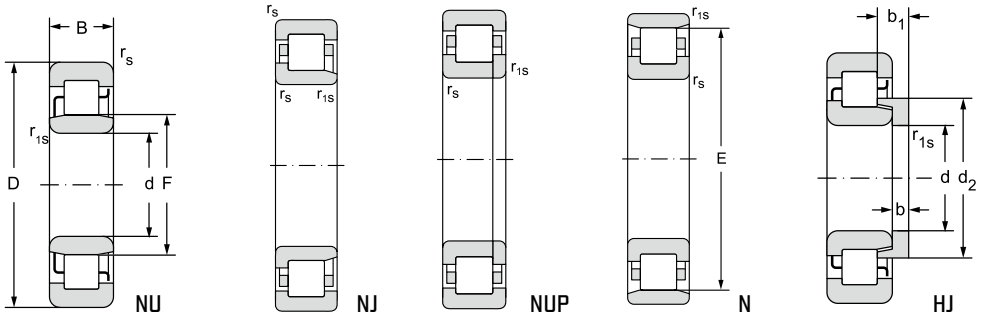

12.4.1

Main dimensions											Bearing designation	Other cages	Angle ring designation	Basic load rating		
d	D	B	r _s	r _{1s}	F	E	d ₂	b	b ₁	s ₁				C _r	C _{or}	
			min	min			max				kN					
mm																
110	200	38,00	2,1	2,1	132,5		143,1	11,0	18,50	2,5	NU222		HJ222	237,0	271,0	
	200	38,00	2,1	2,1	132,5		143,1	11,0	18,50	2,5	NJ222		HJ222	237,0	271,0	
	200	38,00	2,1	2,1	132,5					2,5	NUP222			237,0	271,0	
	200	38,00	2,1	2,1		178,5					2,5	N222			237,0	271,0
	200	53,00	2,1	2,1	132,5					5,0	NU2222M			341,0	422,0	
	200	53,00	2,1	2,1	132,5					5,0	NJ2222M			341,0	422,0	
	200	53,00	2,1	2,1	132,5					5,0	NUP2222M			341,0	422,0	
	200	69,85	2,1	4,0	132,951					7,0	NU5222M			464,0	736,0	
	240	50,00	3,0	3,0	143		157,5	14,0	23,00	2,7	NU322		HJ322	391,0	414,0	
	240	50,00	3,0	3,0	143		157,5	14,0	23,00	2,7	NJ322		HJ322	391,0	414,0	
	240	50,00	3,0	3,0	143					2,7	NUP322			391,0	414,0	
	240	50,00	3,0	3,0		207,0				2,7	N322			391,0	414,0	
	240	50,00	3,0	3,0	143					2,9	NU322EM			447,0	492,0	
	240	50,00	3,0	3,0	143					2,9	NJ322EM			447,0	492,0	
240	50,00	3,0	3,0	143					2,9	NUP322EM			447,0	492,0		
280	65,00	4,0	4,0	155		173,4	17,0	29,50	2,7	NU422M		HJ422	584,0	631,0		
280	65,00	4,0	4,0	155		173,4	17,0	29,50	2,7	NJ422M		HJ422	584,0	631,0		
280	65,00	4,0	4,0	155					2,7	NUP422M			584,0	631,0		
120	180	28,00	2,0	1,1	135					2,0	NU1024			131,0	168,0	
	215	40,00	2,1	2,1	143,5		154,5	11,0	19,00	2,5	NU224		HJ224	261,0	299,0	
	215	40,00	2,1	2,1	143,5		154,5	11,0	19,00	2,5	NJ224		HJ224	261,0	299,0	
	215	40,00	2,1	2,1	143,5					2,5	NUP224			261,0	299,0	
	215	40,00	2,1	2,1		191,5				2,5	N224			261,0	299,0	
	215	58,00	2,1	2,1	143,5					5,4	NU2224M			369,0	473,0	
	215	58,00	2,1	2,1	143,5					5,4	NJ2224M			369,0	473,0	
	215	58,00	2,1	2,1	143,5					5,4	NUP2224M			369,0	473,0	
	215	76,20	2,1	2,1	145,14					7,0	NU5224M			482,0	794,0	
	260	55,00	3,0	3,0	154		170,5	14,0	23,50	2,7	NU324		HJ324	447,0	473,0	
	260	55,00	3,0	3,0	154		170,5	14,0	23,50	2,7	NJ324		HJ324	447,0	473,0	
	260	55,00	3,0	3,0	154					2,7	NUP324			447,0	473,0	
	260	86,00	3,0	3,0	154					6,4	NU2324EMAS	M		810,0	981,0	
	260	86,00	3,0	3,0	154					6,4	NJ2324EMAS	M		810,0	981,0	
	260	86,00	3,0	3,0	154					6,4	NUP2324EMAS	M		810,0	981,0	
	310	72,00	5,0	6,0	170		188,0	17,0	30,50	2,7	NU424M		HJ424	736,0	810,0	
	310	72,00	5,0	6,0	170		188,0	17,0	30,50	2,7	NJ424M		HJ424	736,0	810,0	
310	72,00	5,0	6,0	170					2,7	NUP424M			736,0	810,0		

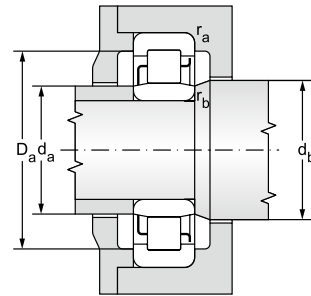
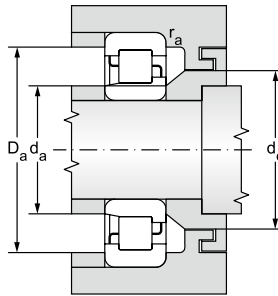
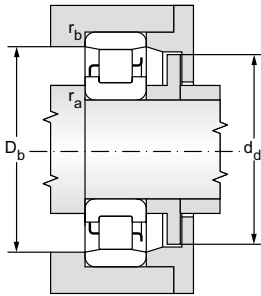

¹⁾ Admissible axial movement



Fatigue load limit	Limiting speed for lubrication with		Abutment and fillet dimensions										Weight		
	P_u	grease	oil	d	d_a	d_a	d_b	d_c	d_d	D_a	D_b	r_a	r_b	~	Ang.r.
kN	min^{-1}			min	max	min	min	max	max	min	max	max	max	of bearing	kg
28,98	3200	3800	110	122	125,0	135,0	145	-	188	-	2,0	2,0		4,65	0,62
28,98	3200	3800		122	125,0	135,0	145	-	188	-	2,0	2,0		4,65	0,62
28,98	3200	3800		122	125,0	135,0	-	-	188	-	2,0	2,0		4,65	
28,98	3200	3800		122	125,0	135,0	-	175	188	182	2,0	2,0		4,65	
45,12	3200	3800		122	125,0	135,0	-	-	188	-	2,0	2,0		6,95	
45,12	3200	3800		122	125,0	135,0	-	-	188	-	2,0	2,0		6,95	
45,12	3200	3800		122	125,0	135,0	-	-	188	-	2,0	2,0		6,95	
78,70	3000	3500		128	-	137,0	-	-	180	-	3,0	2,0		10,00	
42,68	2500	3000		124	135,0	145,0	160	-	226	-	2,5	2,5		10,5	1,17
42,68	2500	3000		124	135,0	145,0	160	-	226	-	2,5	2,5		10,5	1,17
42,68	2500	3000		124	135,0	145,0	-	-	226	-	2,5	2,5		10,5	
42,68	2500	3000		124	135,0	145,0	-	204	226	211	2,5	2,5		10,5	
50,73	2400	2800		124	135,0	145,0	-	-	226	-	2,5	2,5		11,0	
50,73	2400	2800		124	135,0	145,0	-	-	226	-	2,5	2,5		11,0	
50,73	2400	2800		124	135,0	145,0	-	-	226	-	2,5	2,5		11,0	
62,98	2100	2500		130	140,0	157,0	175	-	260	-	3,0	3,0		20,0	2,16
62,98	2100	2500		130	140,0	157,0	175	-	260	-	3,0	3,0		20,0	2,16
62,98	2100	2500		130	140,0	157,0	-	-	260	-	3,0	3,0		20,0	
18,14	3300	4000	120	128	131,0	138,0	-	-	171	-	2,0	1,0		2,45	
31,24	3000	3500		132	138,0	146,0	157	-	203	-	2,0	2,0		5,65	0,72
31,24	3000	3500		132	138,0	146,0	157	-	203	-	2,0	2,0		5,65	0,72
31,24	3000	3500		132	138,0	146,0	-	-	203	-	2,0	2,0		5,65	
31,24	3000	3500		132	138,0	146,0	-	188	203	196	2,0	2,0		5,65	
49,41	3000	3500		132	138,0	146,0	-	-	203	-	2,0	2,0		8,55	
49,41	3000	3500		132	138,0	146,0	-	-	203	-	2,0	2,0		8,55	
49,41	3000	3500		132	138,0	146,0	-	-	203	-	2,0	2,0		8,55	
82,95	2700	3200		140	-	149,0	-	-	194	-	2,0	2,0		11,8	
47,58	2400	2800		134	145,0	156,0	172	-	246	-	2,5	2,5		13,0	1,40
47,58	2400	2800		134	145,0	156,0	172	-	246	-	2,5	2,5		13,0	1,40
47,58	2400	2800		134	145,0	156,0	-	-	246	-	2,5	2,5		13,0	
98,68	2100	2500		134	145,0	156,0	-	-	246	-	2,5	2,5		24,5	
98,68	2100	2500		134	145,0	156,0	-	-	246	-	2,5	2,5		24,5	
98,68	2100	2500		134	145,0	156,0	-	-	246	-	2,5	2,5		24,5	
78,51	1900	2200		144	155,0	172,0	192	-	286	-	4,0	4,0		28,0	2,60
78,51	1900	2200		144	155,0	172,0	192	-	286	-	4,0	4,0		28,0	2,60
78,51	1900	2200		144	155,0	172,0	-	-	286	-	4,0	4,0		28,0	

Single row cylindrical roller bearings

d = 130 to 160 mm

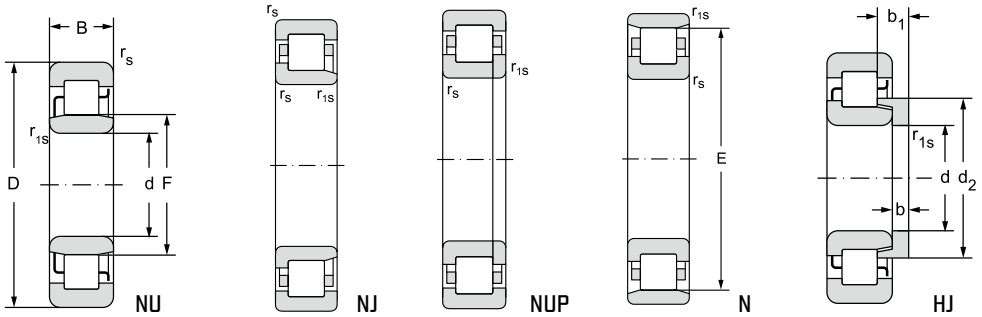

12.4.1

Main dimensions											Bearing designation	Other cages	Angle ring designation	Basic load rating	
d	D	B	r _s	r _{1s}	F	E	d ₂	b	b ₁	s ₁				C _r	C _{or}
			min	min				max							
mm													kN		
130	200	33,00	2,0	1,1	148					2,0	NU1026		162,0	203,0	
	230	40,00	3,0	3,0	156		167,0	11,0	19,00	2,5	NU226	HJ226	271,0	322,0	
	230	40,00	3,0	3,0	156		167,0	11,0	19,00	2,5	NJ226	HJ226	271,0	322,0	
	230	40,00	3,0	3,0	156					2,5	NUP226		271,0	322,0	
	230	40,00	3,0	3,0		204,0				2,5	N226		271,0	322,0	
	230	79,38	4,0	4,0	155					8,0	NU5226M		511,0	841,0	
	280	58,00	4,0	4,0	167		182,3	14,0	23,00	2,9	NU326EM	HJ326E	619,0	694,0	
	280	58,00	4,0	4,0	167		182,3	14,0	23,00	2,9	NJ326EM	HJ326E	619,0	694,0	
	280	58,00	4,0	4,0	167					2,9	NUP326EM		619,0	694,0	
	140	250	42,00	3,0	3,0	169		181,0	11,0	19,00	2,5	NU228	HJ228	310,0	369,0
250		42,00	3,0	3,0	169		181,0	11,0	19,00	2,5	NJ228	HJ228	310,0	369,0	
250		42,00	3,0	3,0	169					2,5	NUP228		310,0	369,0	
250		42,00	3,0	3,0		221,0				2,5	N228		310,0	369,0	
250		82,55	4,0	4,0	168,46					10,0	NU5228M		596,0	981,0	
300		62,00	4,0	4,0	180		198,4	15,0	26,00	2,7	NU328M	HJ328	619,0	708,0	
300		62,00	4,0	4,0	180		198,4	15,0	26,00	2,7	NJ328M	HJ328	619,0	708,0	
300		62,00	4,0	4,0	180					2,7	NUP328M		619,0	708,0	
150	225	35,00	2,1	1,5	169,5					2,0	NU1030M		192,0	251,0	
	270	45,00	3,0	3,0	182		194,7	12,0	20,50	2,4	NU230M	HJ230	369,0	455,0	
	270	45,00	3,0	3,0	182		194,7	12,0	20,50	2,4	NJ230M	HJ230	369,0	455,0	
	270	45,00	3,0	3,0	182					2,4	NUP230M		369,0	455,0	
	270	45,00	3,0	3,0	182		193,7	12,0	19,50	2,4	NU230EM	HJ230E	447,0	552,0	
	270	45,00	3,0	3,0	182		193,7	12,0	19,50	2,4	NJ230EM	HJ230E	447,0	552,0	
	270	45,00	3,0	3,0	182					2,4	NUP230EM		447,0	552,0	
	270	88,90	2,3	2,3	181,544					10,0	NU5230M		736,0	1260,0	
	320	65,00	4,0	4,0	193		212,3	15,0	26,50	2,7	NU330M	HJ330	681,0	779,0	
	320	65,00	4,0	4,0	193		212,3	15,0	26,50	2,7	NJ330M	HJ330	681,0	779,0	
	320	65,00	4,0	4,0	193					2,7	NUP330M		681,0	779,0	
	160	240	38,00	2,1	2,1	180		188,0	10,0	19,00	5,2	NU1032M	HJ1032	229,0	325,0
240		38,00	2,1	2,1	180		188,0	10,0	19,00	5,2	NJ1032M	HJ1032	229,0	325,0	
290		48,00	3,0	3,0	195		207,4	12,0	20,00	2,5	NU232M	HJ232	511,0	631,0	
290		48,00	3,0	3,0	195		207,4	12,0	20,00	2,5	NJ232M	HJ232	511,0	631,0	
290		48,00	3,0	3,0	195					2,5	NUP232M		511,0	631,0	
290		98,42	2,5	6,3	193,634					10,0	NU5232M		764,0	1310,0	
340		68,00	4,0	4,0	204		221,0	15,0	25,00	4,0	NU332EM	MA HJ332E	900,0	1080,0	
340		68,00	4,0	4,0	204		221,0	15,0	25,00	4,0	NJ332EM	MA HJ332E	900,0	1080,0	

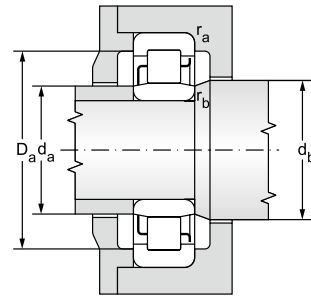
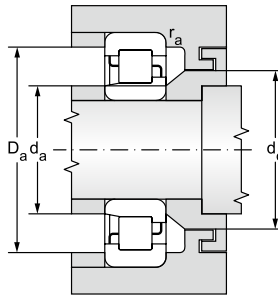
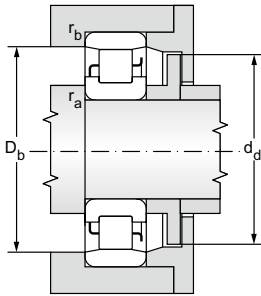

¹⁾ Admissible axial movement



Fatigue load limit	Limiting speed for lubrication with		Abutment and fillet dimensions										Weight		
	P_u	grease	oil	d	d_a	d_a	d_b	d_c	d_d	D_a	D_b	r_a	r_b	~	Ang.r.
kN	min^{-1}			min	max	min	min	max	max	min	max	max	max	of bearing	kg
21,30	3200	3800	130	138	143,0	151,0	-	-	191	-	2,0	1,0		3,75	
32,92	2700	3200		144	150,0	158,0	169	-	216	-	2,5	2,5		6,50	0,84
32,92	2700	3200		144	150,0	158,0	169	-	216	-	2,5	2,5		6,50	0,84
32,92	2700	3200		144	150,0	158,0	-	-	216	-	2,5	2,5		6,50	
32,92	2700	3200		144	150,0	158,0	-	201	216	208	2,5	2,5		6,50	
85,98	2500	3000		149	-	159,0	-	-	207	-	3,0	2,0		13,8	
68,24	2000	2400		148	155,0	169,0	186	-	262	-	3,0	3,0		17,0	1,65
68,24	2000	2400		148	155,0	169,0	186	-	262	-	3,0	3,0		17,0	1,65
68,24	2000	2400		148	155,0	169,0	-	-	262	-	3,0	3,0		17,0	
36,83	2500	3000	140	154	160,0	171,0	182	-	236	-	2,5	2,5		8,25	1,00
36,83	2500	3000		154	160,0	171,0	182	-	236	-	2,5	2,5		8,25	1,00
36,83	2500	3000		154	160,0	171,0	-	-	236	-	2,5	2,5		8,25	
36,83	2500	3000		154	160,0	171,0	-	218	236	255	2,5	2,5		8,25	
97,91	2200	2700		162	-	173,0	-	-	225	-	3,0	3,0		17,1	
68,15	2000	2400		158	166,0	182,0	198	-	282	-	3,0	3,0		20,0	2,05
68,15	2000	2400		158	166,0	182,0	198	-	282	-	3,0	3,0		20,0	2,05
68,15	2000	2400		158	166,0	182,0	-	-	282	-	3,0	3,0		20,0	
25,35	2700	3200	150	159	165,0	173,0	-	-	213	-	2,0	1,5		4,85	
44,42	2200	2700		164	170,0	184,0	196	-	256	-	2,5	2,5		10,5	1,35
44,42	2200	2700		164	170,0	184,0	196	-	256	-	2,5	2,5		10,5	1,35
44,42	2200	2700		164	170,0	184,0	-	-	256	-	2,5	2,5		10,5	
53,88	2200	2700		164	170,0	184,0	196	-	256	-	2,5	2,5		11,0	1,30
53,88	2200	2700		164	170,0	184,0	196	-	256	-	2,5	2,5		11,0	1,30
53,88	2200	2700		164	170,0	184,0	-	-	256	-	2,5	2,5		11,0	
123,00	2000	2400		174	-	187,0	-	-	243	-	5,0	2,0		22,9	
73,52	1900	2200		168	185,0	195,0	213	-	302	-	3,0	3,0		27,0	2,37
73,52	1900	2200		168	185,0	195,0	213	-	302	-	3,0	3,0		27,0	2,37
73,52	1900	2200		168	185,0	195,0	-	-	302	-	3,0	3,0		27,0	
32,19	2500	3000	160	167	177,0	191,0	-	-	230	-	2,0	2,0		6,10	0,65
32,19	2500	3000		167	177,0	191,0	-	-	230	-	2,0	2,0		6,10	0,65
60,33	2000	2400		174	180,0	197,0	210	-	276	-	2,5	2,5		14,7	1,50
60,33	2000	2400		174	180,0	197,0	210	-	276	-	2,5	2,5		14,7	1,50
60,33	2000	2400		174	180,0	197,0	-	-	276	-	2,5	2,5		14,7	
125,26	1900	2200		186	-	199,0	-	-	261	-	5,0	2,0		28,9	
100,05	1700	2000		177	200,0	225,0	-	-	323	-	3,0	3,0		32,2	2,55
100,05	1700	2000		177	200,0	225,0	-	-	323	-	3,0	3,0		32,2	2,55

Single row cylindrical roller bearings

d = 170 to 200 mm

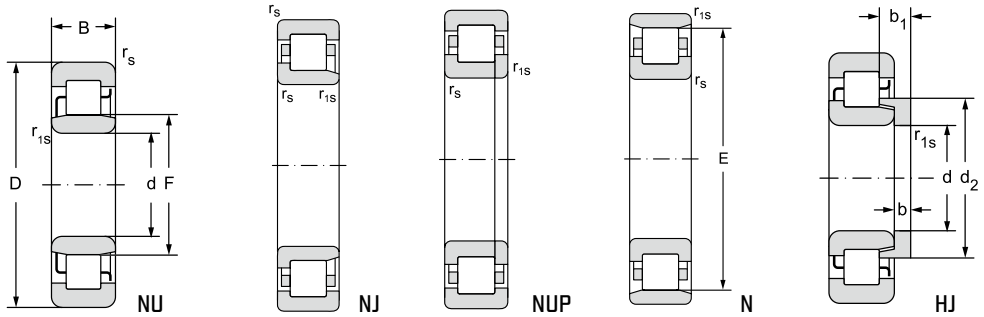

12.4.1

Main dimensions											Bearing designation	Other cages	Angle ring designation	Basic load rating	
d	D	B	r _s	r _{1s}	F	E	d ₂	b	b ₁	s ₁				C _r	C _{or}
			min	min			max								
mm													kN		
170	260	42,00	2,1	2,1	193					3,0	NU1034M			276,0	376,0
	310	52,00	4,0	4,0	207		228,8	12,0	20,00	2,9	NU234M		HJ234	607,0	750,0
	310	52,00	4,0	4,0	207		228,8	12,0	20,00	2,9	NJ234M		HJ234	607,0	750,0
	310	52,00	4,0	4,0	207					2,9	NUP234M			607,0	750,0
	310	104,77	3,2	6,3	205,483					10,0	NU5234M			891,0	1470,0
	360	72,00	4,0	4,0	218					4,6	NU334EM	MA		950,0	1180,0
	360	72,00	4,0	4,0	218					4,6	NJ334EM	MA		950,0	1180,0
180	280	46,00	2,1	2,1	205					3,6	NU1036M			329,0	447,0
	280	46,00	2,1	2,1	205					3,6	NJ1036M			329,0	447,0
	320	52,00	4,0	4,0	217		230,8	12,0	20,00	2,9	NU236M		HJ236	631,0	794,0
	320	52,00	4,0	4,0	217		230,8	12,0	20,00	2,9	NJ236M		HJ236	631,0	794,0
	320	52,00	4,0	4,0	217					2,9	NUP236M			631,0	794,0
	320	86,00	4,0	4,0	218		230,5	12,0	29,00	6,9	NU2236M		HJ2236	736,0	1060,0
	320	86,00	4,0	4,0	218		230,5	12,0	29,00	6,9	NJ2236M		HJ2236	736,0	1060,0
	320	86,00	4,0	4,0	218					6,9	NUP2236M			736,0	1060,0
	380	75,00	4,0	4,0	231					4,6	NU336EM	MA		1020,0	1290,0
	380	75,00	4,0	4,0	231					4,6	NJ336EM	MA		1020,0	1290,0
190	290	46,00	2,1	2,1	215		225,0	12,0	22,50	6,1	NU1038M		HJ1038	350,0	500,0
	290	46,00	2,1	2,1	215		225,0	12,0	22,50	6,1	NJ1038M		HJ1038	350,0	500,0
	340	55,00	4,0	4,0	230		244,0	13,0	21,50	3,0	NU238EM	MA	HJ238E	770,0	965,0
	340	55,00	4,0	4,0	230		244,0	13,0	21,50	3,0	NJ238EM	MA	HJ238E	770,0	965,0
	340	92,00	4,0	4,0	228					5,0	NU2238EM			1220,0	1600,0
	400	78,00	5,0	5,0	245		264,0	18,0	29,00	4,3	NU338EM	MA	HJ338E	1140,0	1500,0
	400	78,00	5,0	5,0	245		264,0	18,0	29,00	4,3	NJ338EM	MA	HJ338E	1140,0	1500,0
200	310	51,00	2,1	2,1	229					4,2	NU1040M	MA		383,0	531,0
	360	58,00	4,0	4,0	243		258,2	14,0	23,00	2,9	NU240EM	MA	HJ240E	779,0	1000,0
	360	58,00	4,0	4,0	243		258,2	14,0	23,00	2,9	NJ240EM	MA	HJ240E	779,0	1000,0
	360	58,00	4,0	4,0	243					2,9	NUP240EM	MA		779,0	1000,0
	360	98,00	4,0	4,0	241					5,1	NU2240EM	MA		1360,0	1800,0
	360	98,00	4,0	4,0	241					5,1	NJ2240EM	MA		1360,0	1800,0
	420	80,00	5,0	5,0	258					6,0	NU340EM	MA		1230,0	1630,0
	420	138,00	5,0	5,0	253					9,4	NU2340EMA			1980,0	2800,0
	420	138,00	5,0	5,0	253					9,4	NJ2340EMA			1980,0	2800,0

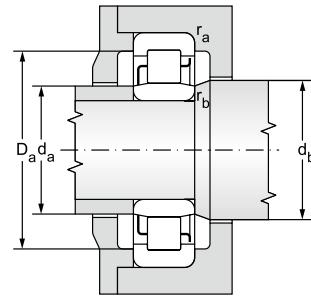
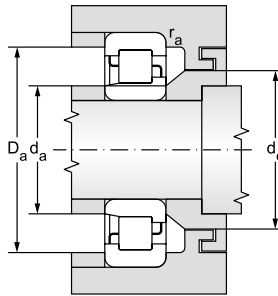
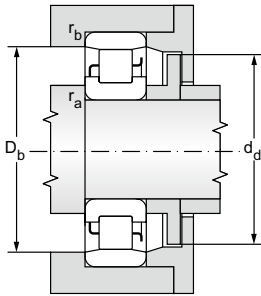

¹⁾ Admissible axial movement



Fatigue load limit	Limiting speed for lubrication with		Abutment and fillet dimensions										Weight		
	P_u	grease	oil	d	d_a	d_a	d_b	d_c	d_d	D_a	D_b	r_a	r_b	~	Ang.r.
kN	min^{-1}			min	max	min	min	max	max	min	max	max	of bearing	kg	
36,45	2200	2700	170	179	190,0	197,0	-	-	248	-	2,0	2,0	7,90		
70,34	1900	2200		188	195,0	211,0	223	-	293	-	3,0	3,0	16,6	1,70	
70,34	1900	2200		188	195,0	211,0	223	-	293	-	3,0	3,0	16,6	1,70	
70,34	1900	2200		188	195,0	211,0	-	-	293	-	3,0	3,0	16,6		
137,86	1800	2100		197	-	211,0	-	-	279	-	5,0	3,0	35,5		
107,42	1460	1700		187	214,0	221,0	-	-	343	-	3,0	3,0	37,5		
107,42	1460	1700		187	214,0	221,0	-	-	343	-	3,0	3,0	37,5		
42,46	2100	2500	180	189	196,0	209,0	-	-	268	-	2,0	2,0	10,5		
42,46	2100	2500		189	196,0	209,0	-	-	268	-	2,0	2,0	10,5		
73,56	1800	2100		198	207,0	220,0	233	-	302	-	3,0	3,0	19,5	1,80	
73,56	1800	2100		198	207,0	220,0	233	-	302	-	3,0	3,0	19,5	1,80	
73,56	1800	2100		198	207,0	220,0	-	-	302	-	3,0	3,0	19,5		
98,20	1800	2100		198	208,0	221,0	233	-	302	-	3,0	3,0	31,2	1,90	
98,20	1800	2100		198	208,0	221,0	233	-	302	-	3,0	3,0	31,2	1,90	
98,20	1800	2100		198	208,0	221,0	-	-	302	-	3,0	3,0	31,2		
115,51	1370	1600		197	225,0	235,0	-	-	363	-	3,0	3,0	45,0		
115,51	1370	1600		197	225,0	235,0	-	-	363	-	3,0	3,0	45,0		
46,89	2180	2600	190	200	212,0	228,0	-	-	280	-	2,0	2,0	11,0	1,35	
46,89	2180	2600		200	212,0	228,0	-	-	280	-	2,0	2,0	11,0	1,35	
87,85	1700	2000		207	226,0	248,0	-	-	323	-	3,0	3,0	24,5	2,10	
87,85	1700	2000		207	226,0	248,0	-	-	323	-	3,0	3,0	24,5	2,10	
145,66	1700	2000		207	222,0	232,0	-	-	323	-	3,0	3,0	39,0		
132,23	1290	1500		210	240,0	249,0	-	-	380	-	4,0	4,0	50,0	4,30	
132,23	1290	1500		210	240,0	249,0	-	-	380	-	4,0	4,0	50,0	4,30	
48,90	1900	2200	200	212	220,0	233,0	-	-	298	-	2,0	2,0	14,0		
89,54	1500	1800		218	227,0	246,0	261	-	342	-	3,0	3,0	28,4	2,70	
89,54	1500	1800		218	227,0	246,0	261	-	342	-	3,0	3,0	28,4	2,70	
89,54	1500	1800		218	227,0	246,0	-	-	342	-	3,0	3,0	28,4		
161,18	1610	1900		217	235,0	245,0	-	-	343	-	3,0	3,0	46,0		
161,18	1610	1900		217	235,0	245,0	-	-	343	-	3,0	3,0	46,0		
141,57	1200	1400		220	254,0	262,0	-	-	400	-	4,0	4,0	57,5		
243,18	1200	1400		220	249,0	280,0	-	-	400	-	4,0	4,0	97,0		
243,18	1200	1400		220	249,0	280,0	-	-	400	-	4,0	4,0	97,0		

Single row cylindrical roller bearings

d = 220 to 300 mm

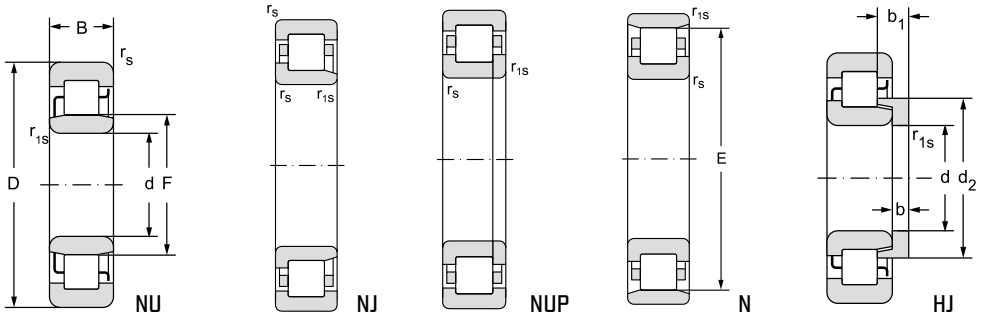

12.4.1

Main dimensions											Bearing designation	Other cages	Angle ring designation	Basic load rating	
d	D	B	r _s	r _{1s}	F	E	d ₂	b	b ₁	s ₁				C _r	C _{or}
			min	min				max				kN			
mm															
220	300	48,00	2,1	2,1	242					3,0	NU2944M	MA		460,0	830,0
	340	56,00	3,0	3,0	250					4,1	NU1044M	MA		514,0	775,0
	340	56,00	3,0	3,0	250					4,1	NJ1044M			514,0	775,0
	400	65,00	4,0	4,0	268		284,0	15,0	25,00	4,0	NU244EM	MA	HJ244E	1050,0	1290,0
	400	65,00	4,0	4,0	268		284,0	15,0	25,00	4,0	NJ244EM	MA	HJ244E	1050,0	1290,0
	400	108,00	4,0	4,0	259					7,9	NU2244EMA			1630,0	2350,0
	460	88,00	5,0	5,0	284					5,2	NU344M			1240,0	1650,0
	460	88,00	5,0	5,0	284					5,2	NJ344M			1240,0	1650,0
	460	145,00	5,0	5,0	275					10,4	NU2344EM	MA		2350,0	3420,0
240	360	56,00	3,0	3,0	270					4,1	NU1048MA			531,0	764,0
	440	72,00	4,0	4,0	295		315,0	16,0	25,90	4,0	NU248MA		HJ248	944,0	1280,0
	440	72,00	4,0	4,0	295		315,0	16,0	25,90	4,0	NJ248MA		HJ248	944,0	1280,0
	440	120,00	4,0	4,0	295					4,3	NU2248MA			1460,0	2360,0
	440	120,00	4,0	4,0	295					4,3	NJ2248MA			1460,0	2360,0
	500	95,00	5,0	5,0	310		335,0	22,0	39,50	5,6	NU348M	MA	HJ348	1450,0	2000,0
	500	95,00	5,0	5,0	310		335,0	22,0	39,50	5,6	NJ348M	MA	HJ348	1450,0	2000,0
	500	155,00	5,0	5,0	299					6,4	NU2348EMA			2600,0	3600,0
260	400	65,00	4,0	4,0	296					2,0	NU1052M	MA, F		642,0	996,0
	400	65,00	4,0	4,0	296					2,0	NJ1052M	MA, F		642,0	996,0
	400	65,00	4,0	4,0	296					2,0	NUP1052M	MA, F		642,0	996,0
	480	80,00	5,0	5,0	320		340,0	18,0	33,00	3,4	NU252MA		HJ252	1160,0	1700,0
	480	80,00	5,0	5,0	320		340,0	18,0	33,00	3,4	NJ252MA		HJ252	1160,0	1700,0
	480	130,00	5,0	5,0	320					4,3	NU2252MA			1760,0	2900,0
	480	130,00	5,0	5,0	320					4,3	NJ2252MA			1760,0	2900,0
	540	102,00	6,0	6,0	337					4,2	NU352EMA			1900,0	2680,0
	540	165,00	6,0	6,0	319					1,8	NU2352EMA			3100,0	4400,0
280	420	65,00	4,0	4,0	316					5,0	NU1056MA			681,0	1020,0
	500	80,00	5,0	5,0	340					3,8	NU256MA			1120,0	1670,0
	500	80,00	5,0	5,0	340					3,8	NJ256MA			1120,0	1670,0
	500	130,00	5,0	5,0	330					10,0	NU2256EMA			2190,0	3410,0
	580	175,00	6,0	6,0	362					6,6	NU2356MA			2700,0	4300,0
300	460	74,00	5,0	5,0	340					4,5	NU1060MA	M, F		885,0	1400,0
	460	74,00	5,0	5,0	340					4,5	NJ1060MA	M, F		885,0	1400,0
	540	85,00	5,0	5,0	364					4,8	NU260M	MA		1430,0	2150,0
	540	140,00	5,0	5,0	364					5,6	NU2260MA			2100,0	3470,0
	620	185,00	7,5	7,5	371					11,0	NU2360EMA			4000,0	5800,0

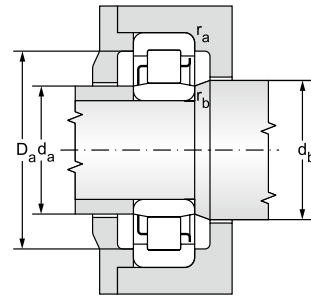
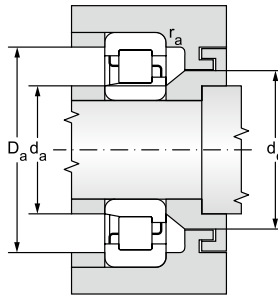
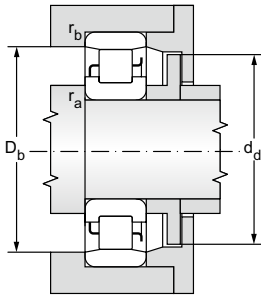

¹⁾ Admissible axial movement

Fatigue load limit	Limiting speed for lubrication with		Abutment and fillet dimensions										Weight		
	P_u	grease	oil	d	d_a	d_a	d_b	d_c	d_d	D_a	D_b	r_a	r_b	~	Ang.r.
kN	min^{-1}			min	max	min	min	max	max	min	max	max	max	of bearing	kg
75,99	2040	2400	220	231	236,0	242,0	-	-	289	-	2,0	2,0		10,00	
69,40	1700	2000		234	240,0	254,0	-	-	326	-	2,5	2,5		18,5	
69,40	1700	2000		234	240,0	254,0	-	-	326	-	2,5	2,5		18,5	
112,04	1360	1600		237	264,0	288,0	-	-	383	-	3,0	3,0		38,2	3,25
112,04	1360	1600		237	264,0	288,0	-	-	383	-	3,0	3,0		38,2	3,25
204,10	1360	1600		237	255,0	264,0	-	-	383	-	3,0	3,0		62,5	
139,39	1290	1500		240	277,0	311,0	-	-	440	-	4,0	4,0		74,0	
139,39	1290	1500		240	277,0	311,0	-	-	440	-	4,0	4,0		74,0	
288,91	1100	1300		240	288,0	280,0	-	-	440	-	4,0	4,0		120	
67,01	1600	1900	240	254	260,0	275,0	-	-	346	-	2,5	2,5		20,0	
108,13	1300	1600		258	293,0	298,0	316	-	422	-	3,0	3,0		50,5	4,68
108,13	1300	1600		258	293,0	298,0	316	-	422	-	3,0	3,0		50,5	4,68
199,37	1270	1500		257	284,0	299,0	-	-	423	-	3,0	3,0		84,0	
199,37	1270	1500		257	284,0	299,0	-	-	423	-	3,0	3,0		84,0	
164,72	1120	1300		260	302,0	339,0	337	-	480	-	4,0	4,0		99,0	8,90
164,72	1120	1300		260	302,0	339,0	337	-	480	-	4,0	4,0		99,0	8,90
296,50	1010	1200		260	293,0	305,0	-	-	480	-	4,0	4,0		155	
84,90	1400	1700	260	278	280,0	300,0	-	-	382	-	3,0	3,0		29,0	
84,90	1400	1700		278	280,0	300,0	-	-	382	-	3,0	3,0		29,0	
84,90	1400	1700		278	280,0	300,0	-	-	382	-	3,0	3,0		29,0	
140,01	1190	1400		280	313,0	344,0	-	-	460	-	4,0	4,0		70,0	6,20
140,01	1190	1400		280	313,0	344,0	-	-	460	-	4,0	4,0		70,0	6,20
238,85	1100	1400		280	309,0	324,0	-	-	460	-	4,0	4,0		90,0	
238,85	1100	1400		280	309,0	324,0	-	-	460	-	4,0	4,0		90,0	
215,63	920	1100		286	330,0	341,0	-	-	514	-	5,0	5,0		125	
354,01	920	1100		286	310,0	323,0	-	-	514	-	5,0	5,0		190	
85,42	1300	1600	280	296	311,0	320,0	-	-	404	-	3,0	3,0		32,5	
135,39	1190	1400		300	333,0	364,0	-	-	480	-	4,0	4,0		73,0	
135,39	1190	1400		300	333,0	364,0	-	-	480	-	4,0	4,0		73,0	
276,45	950	1200		300	322,0	334,0	-	-	480	-	4,0	4,0		120	
338,54	850	1000		306	347,0	366,0	-	-	554	-	5,0	5,0		230	
114,39	1200	1400	300	318	325,0	344,0	360	-	442	-	3,0	3,0		43,6	
114,39	1200	1400		318	325,0	344,0	360	-	442	-	3,0	3,0		43,6	
170,47	1100	1300		320	358,0	368,0	-	-	520	-	4,0	4,0		90,0	
275,13	1020	1200		320	352,0	368,0	-	-	520	-	4,0	4,0		147	
447,49	800	950		332	365,0	375,0	-	-	588	-	6,0	6,0		270	

Single row cylindrical roller bearings

d = 320 to 460 mm

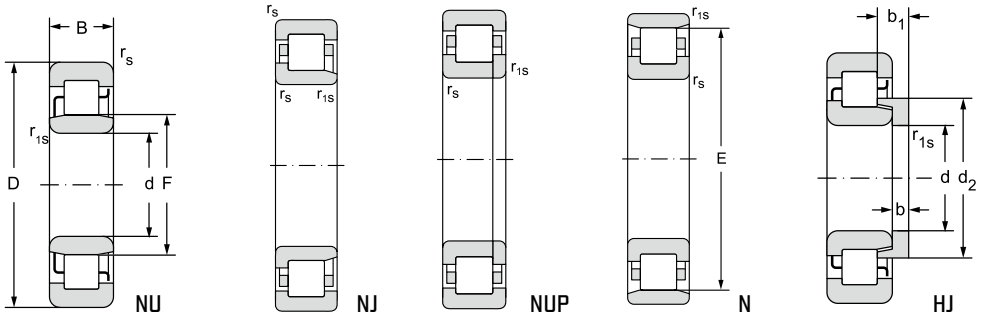

12.4.1

Main dimensions											Bearing designation	Other cages	Angle ring designation	Basic load rating		
d	D	B	r _s	r _{1s}	F	E	d ₂	b	b ₁	s ₁				C _r	C _{or}	
			min	min				max				kN				
320	480	74,00	4,0	4,0	360		376,0	19,0	36,00	5,0		NU1064MA		HJ1064	909,0	1390,0
	480	74,00	4,0	4,0	360		376,0	19,0	36,00	5,0		NJ1064MA		HJ1064	909,0	1390,0
	580	92,00	5,0	5,0	390					5,3		NU264MA			1600,0	2450,0
	580	150,00	5,0	5,0	380					5,9		NU2264EMA			3200,0	5000,0
	580	150,00	5,0	5,0	380					5,9		NJ2264EMA			3200,0	5000,0
340	460	72,00	3,0	3,0	373					8,5		NU2968M			820,0	1700,0
	460	72,00	3,0	3,0	367					3,8		NJ2968EMA			1020,0	2020,0
	520	82,00	5,0	5,0	385		403,0	21,0	39,50	6,5		NU1068MA		HJ1068	1100,0	1780,0
	520	82,00	5,0	5,0	385		403,0	21,0	39,50	6,5		NJ1068MA		HJ1068	1100,0	1780,0
	620	165,00	6,0	6,0	416					8,0		NU2268MA			2600,0	4500,0
360	540	82,00	6,0	6,0	480		423,0	21,0	39,50	5,0		NU1072MA		HJ1072	1076,0	1753,0
	540	82,00	6,0	6,0	480		423,0	21,0	39,50	5,0		NJ1072MA		HJ1072	1076,0	1753,0
	650	170,00	6,0	6,0	437					16,7		NU2272MA			2920,0	4900,0
	750	224,00	7,5	7,5	465					10,0		NU2372EMA			5000,0	8100,0
380	560	82,00	5,0	5,0	425					6,0		NU1076MA			1166,0	1982,0
	560	82,00	5,0	5,0	425					6,0		NJ1076MA			1166,0	1982,0
	680	175,00	6,0	6,0	451					8,3		NU2276EMA			3900,0	6400,0
400	540	82,00	4,0	4,0	438					7,6		NU2980MA**			1150,0	2450,0
	600	90,00	5,0	5,0	450		470,0	19,6	42,60	5,0		NU1080MA**		HJ1080	1470,0	2330,0
	600	90,00	5,0	5,0	450		470,0	19,6	42,60	5,0		NJ1080MA**		HJ1080	1470,0	2330,0
	600	148,00	5,0	5,0	450					5,0		NU3080MA**			2255,0	4900,0
	720	185,00	6,0	6,0	480					16,0		NU2280MA**			3410,0	5960,0
420	560	82,00	4,0	4,0	458					2,4		NU2984MA**			1200,0	2550,0
	620	90,00	5,0	5,0	470		490,0	23,0	43,00	14,0		NU1084MA**		HJ1084	1420,0	2450,0
	620	150,00	5,0	5,0	458,2					13,0		NU3084EMA**			2900,0	5400,0
440	600	95,00	4,0	4,0	481,5					3,5		NU2988EM**			1720,0	3600,0
	650	94,00	6,0	6,0	493		512,0	24,0	45,00	14,7		NU1088MA**		HJ1088	1500,0	2600,0
460	620	95,00	4,0	4,0	495					4,0		NU2992EMA**			1700,0	3600,0
	680	100,00	6,0	6,0	516		537,0	25,0	48,00	15,9		NU1092MA**		HJ1092	1650,0	2850,0
	680	163,00	6,0	6,0	499					7,2		NU3092EMA**			3400,0	6300,0
	830	212,00	7,5	7,5	554					16,5		NU2292MA**			5100,0	8600,0

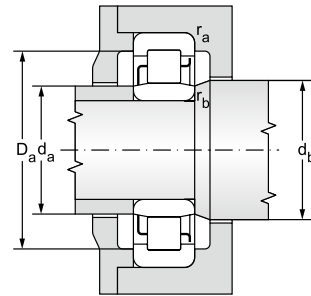
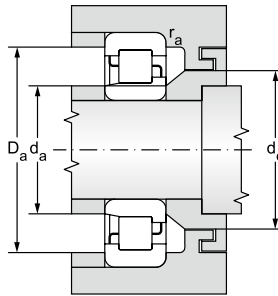
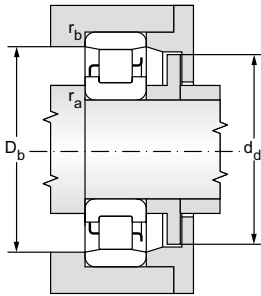

¹⁾ Admissible axial movement

Fatigue load limit	Limiting speed for lubrication with		Abutment and fillet dimensions										Weight		
	P_u	grease	oil	d	d_a	d_a	d_b	d_c	d_d	D_a	D_b	r_a	r_b	~	Ang.r.
kN	min^{-1}			min	max	min	min	max	max	min	max	max	max	of bearing	kg
111,84	1100	1300	320	336	355,0	364,0	-	-	464	-	3,0	3,0		48,5	5,65
111,84	1100	1300		336	355,0	364,0	-	-	464	-	3,0	3,0		48,5	5,65
190,28	1020	1200		340	383,0	394,0	-	-	560	-	4,0	4,0		115	
388,32	850	1000		340	377,0	410,0	-	-	560	-	4,0	4,0		190	
388,32	850	1000		340	377,0	410,0	-	-	560	-	4,0	4,0		190	
136,78	1190	1400	340	353	369,0	377,0	-	-	447	-	2,5	2,5		36,0	
162,52	1190	1400		353	363,0	381,0	-	-	447	-	2,5	2,5		37,0	
140,14	1090	1300		358	380,0	408,0	-	-	502	-	4,0	4,0		68,0	7,40
140,14	1090	1300		358	380,0	408,0	-	-	502	-	4,0	4,0		68,0	7,40
342,79	850	1000		366	401,0	421,0	-	-	594	-	5,0	5,0		220	
136,15	950	1100	360	382	390,0	410,0	427	-	518	-	4,0	4,0		67,5	10,00
136,15	950	1100		382	390,0	410,0	427	-	518	-	4,0	4,0		67,5	10,00
367,62	800	950		386	428,0	442,0	-	-	624	-	5,0	5,0		250	
590,72	720	850		392	453,0	470,0	-	-	718	-	6,0	6,0		510	
151,94	850	1000	380	400	420,0	430,0	-	-	540	-	4,0	4,0		71,0	
151,94	850	1000		400	420,0	430,0	-	-	540	-	4,0	4,0		71,0	
473,24	720	850		406	445,0	457,0	-	-	654	-	5,0	5,0		275	
187,81	1020	1200	400	415	434,0	442,0	-	-	525	-	3,0	3,0		54,5	
175,33	840	1000		422	435,0	455,0	-	-	578	-	4,0	4,0		89,0	10,5
175,33	840	1000		422	435,0	455,0	-	-	578	-	4,0	4,0		89,0	10,5
368,72	760	910		422	435,0	455,0	-	-	578	-	4,0	4,0		151	
433,49	710	840		426	460,0	485,0	-	-	694	-	5,0	5,0		350	
193,05	930	1100	420	435	452,0	463,0	-	-	545	-	3,0	3,0		59,0	
182,20	930	1100		438	466,0	475,0	-	-	602	-	4,0	4,0		96,0	10,00
401,59	760	900		438	450,0	478,0	-	-	602	-	4,0	4,0		160	
267,72	930	1100	440	455	477,0	500,0	-	-	585	-	3,0	3,0		84,0	
190,65	840	1000		463	488,0	498,0	-	-	627	-	5,0	5,0		105	11,5
264,71	850	1000	460	475	490,0	515,0	-	-	605	-	3,0	3,0		89,0	
206,19	800	950		483	511,0	521,0	-	-	657	-	5,0	5,0		115	14,0
455,79	680	800		483	491,0	504,0	-	-	657	-	5,0	5,0		210	
599,54	600	700		492	542,0	559,0	-	-	798	-	6,0	6,0		530	

Single row cylindrical roller bearings

d = 480 to 750 mm

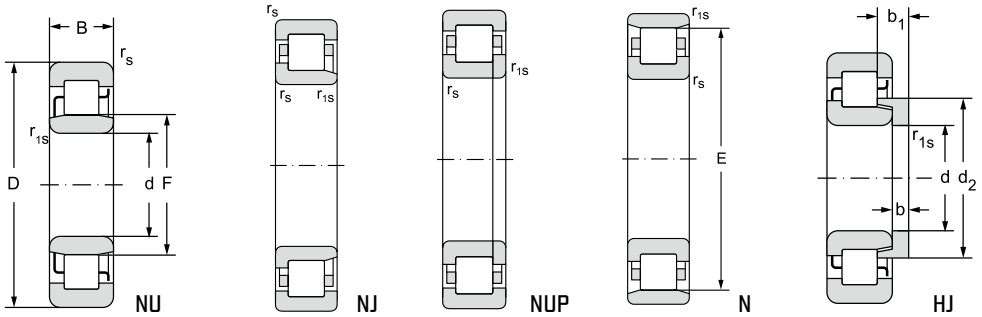

12.4.1

Main dimensions											Bearing designation	Other cages	Angle ring designation	Basic load rating		
d	D	B	r _s	r _{1s}	F	E	d ₂	b	b ₁	s ₁				C _r	C _{or}	
mm														kN		
			min	min			max									
480	700	100,00	6,0	6,0	536		557,0	25,0	48,00	15,9		NU1096MA**		HJ1096	1680,0	3000,0
500	720	100,00	6,0	6,0	556		577,0	25,0	48,00	11,2		NU10/500MA**		HJ10/500	1720,0	3100,0
	720	167,00	6,0	6,0	540,8							NU30/500EMA**	FA		4000,0	8000,0
	920	185,00	7,5	7,5	603,1							NU12/500MA**			5300,0	8500,0
530	710	106,00	5,0	5,0	573					3,3		NU29/530EMA**			2380,0	5000,0
	780	112,00	6,0	6,0	593					10,4		NU10/530MA**			2290,0	4050,0
560	750	112,00	5,0	5,0	608					4,5		NU29/560EMA**			2460,0	5400,0
	820	115,00	6,0	6,0	625		648,0	27,5	53,00	12,3		NU10/560MA**		HJ10/560	2300,0	4200,0
	820	115,00	6,0	6,0	625		648,0	27,5	53,00	12,3		NJ10/560MA**		HJ10/560	2300,0	4200,0
	1030	206,00	9,5	9,5	668					10,3		NU12/560MA**			7200,0	11200,0
600	800	118,00	5,0	5,0	650					12,0		NU29/600MA**			2230,0	4853,0
	800	118,00	5,0	5,0	650					12,0		NUP29/600MA**			2230,0	4853,0
	830	150,00	4,7	4,7	659					7,0		NU39/600MA**			2860,0	6200,0
	870	118,00	6,0	6,0	667		695,0	31,0	55,00	14,0		NU10/600MA**		HJ10/600	2750,0	5100,0
	1090	155,00	9,5	9,5	749					3,0		NU2/600EMA**			5600,0	9800,0
630	850	128,00	6,0	6,0	683					7,1		NU29/630EMA**			3300,0	7200,0
	850	128,00	6,0	6,0	683					7,1		NJ29/630EMA**			3300,0	7200,0
	850	128,00	6,0	6,0	683					7,1		NUP29/630EMA**			3300,0	7200,0
	920	128,00	7,5	7,5	702					6,2		NU10/630MA**			3400,0	6200,0
	920	128,00	7,5	7,5	702					6,2		NUP10/630MA**			3400,0	6200,0
	1150	230,00	12,0	12,0	751					13,5		NU12/630EMA**			8500,0	13600,0
670	980	136,00	7,5	7,5	747					7,9		NU10/670EMA**			3700,0	6800,0
710	950	140,00	6,0	6,0	766					10,0		NU29/710EMA**			3740,0	8250,0
	950	140,00	6,0	6,0	766					10,0		NUP29/710EMA**			3740,0	8250,0
	1030	140,00	7,5	7,5	778					17,0		NU10/710EMA**			4600,0	8500,0
750	1090	150,00	7,5	7,5	830					12,8		NU10/750EMA**			4700,0	8800,0
	1090	195,00	7,5	7,5	832					12,8		NU20/750EMA**			7000,0	14500,0

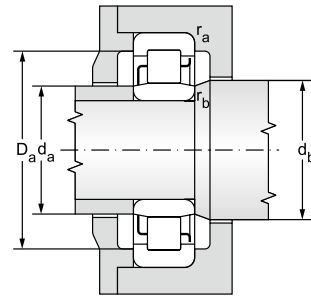
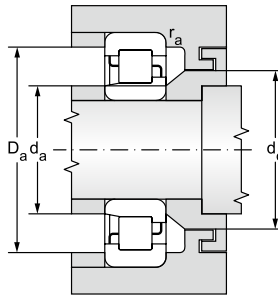
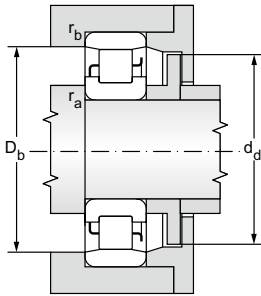

¹⁾ Admissible axial movement

Fatigue load limit	Limiting speed for lubrication with		Abutment and fillet dimensions										Weight		
	P_u	grease	oil	d	d_a	d_a	d_b	d_c	d_d	D_a	D_b	r_a	r_b	~	Ang.r.
kN	min^{-1}			min	max	min	min	max	max	min	max	max	of bearing	kg	
214,81	750	900	480	503	531,0	541,0	-	-	677	-	5,0	5,0	130	14,5	
219,76	750	900	500	523	550,0	561,0	-	-	697	-	5,0	5,0	135	15,0	
567,12	640	750		523	532,0	546,0	-	-	697	-	5,0	5,0	225		
575,74	570	670		532	593,0	610,0	-	-	888	-	6,0	6,0	585		
352,73	720	850	530	548	566,0	578,0	-	-	692	-	4,0	4,0	120		
281,04	670	800		553	585,0	598,0	-	-	757	-	5,0	5,0	190		
374,72	680	800	560	578	600,0	613,0	-	-	732	-	4,0	4,0	145		
286,93	630	750		583	617,0	655,0	-	-	797	-	5,0	5,0	210	21,0	
286,93	630	750		583	617,0	655,0	-	-	797	-	5,0	5,0	210	21,0	
733,32	470	560		600	657,0	674,0	-	-	990	-	8,0	8,0	805		
330,12	560	700	600	614	644,0	654,0	675	-	750	-	4,0	4,0	173		
330,12	560	700		614	644,0	654,0	675	-	750	-	4,0	4,0	173		
419,07	500	600		614	645,0	660,0	680	-	790	-	4,7	4,7	262		
341,88	590	700		623	658,0	672,0	-	-	847	-	5,0	5,0	245	27,5	
630,02	410	480		640	743,0	755,0	-	-	1050	-	8,0	8,0	710		
481,67	590	700	630	653	678,0	709,0	-	-	827	-	5,0	5,0	230		
481,67	590	700		653	678,0	709,0	-	-	827	-	5,0	5,0	230		
481,67	590	700		653	678,0	709,0	-	-	827	-	5,0	5,0	230		
409,06	530	630		658	691,0	707,0	-	-	892	-	6,0	6,0	285		
409,06	530	630		658	691,0	707,0	-	-	892	-	6,0	6,0	285		
860,81	380	450		678	735,0	757,0	-	-	1102	-	10,0	10,0	1100		
440,31	500	600	670	698	737,0	753,0	-	-	952	-	6,0	6,0	350		
533,23	510	600	710	733	760,0	796,0	-	-	927	-	5,0	5,0	300		
533,23	510	600		733	760,0	796,0	-	-	927	-	5,0	5,0	300		
541,69	470	560		738	769,0	788,0	-	-	1002	-	6,0	6,0	415		
551,48	360	430	750	778	823,0	840,0	-	-	1062	-	6,0	6,0	490		
908,69	360	430		778	823,0	838,0	-	-	1062	-	6,0	6,0	635		

Single row cylindrical roller bearings

d = 800 to 1180 mm

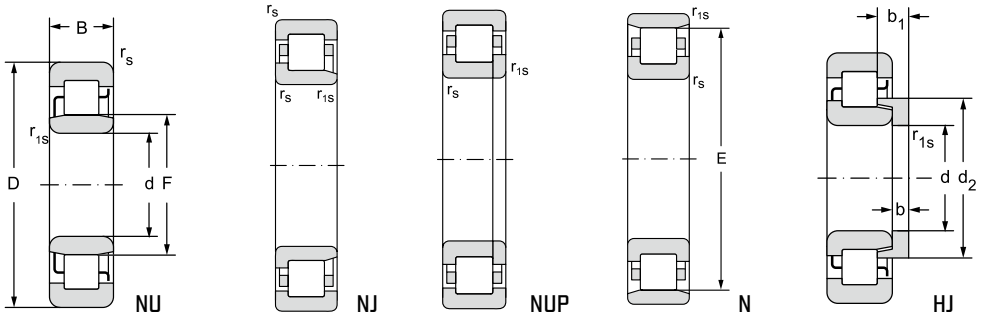

12.4.1

Main dimensions											Bearing designation	Other cages	Angle ring designation	Basic load rating	
d	D	B	r _s	r _{1s}	F	E	d ₂	b	b ₁	s ₁				C _r	C _{or}
			min	min			max								
mm											kN				
800	1150	155,00	7,5	7,5	883						13,0	NU10/800EMA**		5500,0	10500,0
	1150	200,00	7,5	7,5	882						12,0	NU20/800EMA**		7000,0	14500,0
850	1120	155,00	8,0	8,0	925						15,0	NU29/850MA**		3760,0	8740,0
	1120	155,00	8,0	8,0	925						15,0	NUP29/850MA**		3760,0	8740,0
900	1180	165,00	8,0	8,0	982						17,0	NU29/900MA**		4220,0	9810,0
	1180	165,00	8,0	8,0	982						17,0	NUP29/900MA**		4220,0	9810,0
950	1250	175,00	10,0	10,0	1032						17,0	NU29/950MA**		4577,0	11452,0
	1250	175,00	10,0	10,0	1032						17,0	NUP29/950MA**		4577,0	11452,0
1000	1320	185,00	10,0	10,0	1090						17,0	NU29/1000MA**		4920,0	11600,0
	1320	185,00	10,0	10,0	1090						17,0	NUP29/1000MA**		4920,0	11600,0
1060	1400	195,00	10,0	10,0	1155						20,0	NU29/1060MA**		5410,0	12800,0
	1400	195,00	10,0	10,0	1155						20,0	NUP29/1060MA**		5410,0	12800,0
	1400	250,00	7,5	7,5	1146						17,5	NU39/1060EMA**		9100,0	23900,0
1180	1540	206,00	10,0	10,0	1280						21,0	NU29/1180MA**		6310,0	15300,0
	1540	206,00	10,0	10,0	1280						21,0	NUP29/1180MA**		6310,0	15300,0

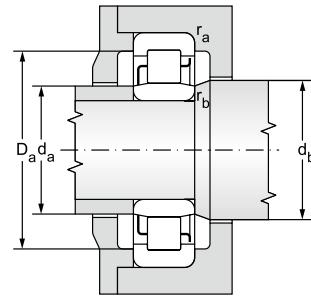
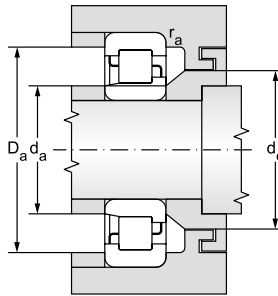
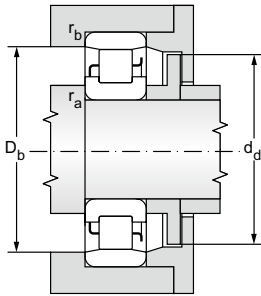

¹⁾ Admissible axial movement



Fatigue load limit	Limiting speed for lubrication with		Abutment and fillet dimensions										Weight		
	P_u	grease	oil	d	d_a	d_a	d_b	d_c	d_d	D_a	D_b	r_a	r_b	~	Ang.r.
kN	min^{-1}			min	max	min	min	max	max	min	max	max	max	of bearing	
646,66	400	480	800	828	869,0	889,0	-	-	1122	-	6,0	6,0		560	
893,00	340	400		828	868,0	888,0	-	-	1122	-	6,0	6,0		715	
536,62	380	450	850	878	920,0	930,0	952	-	1092	-	5,0	5,0		430	
536,62	380	450		878	920,0	930,0	952	-	1092	-	5,0	5,0		430	
592,58	300	400	900	928	977,0	987,0	1011	-	1152	-	5,0	5,0		500	
592,58	300	400		928	977,0	987,0	1011	-	1152	-	5,0	5,0		500	
680,22	300	370	950	978	1027,0	1041,0	1066	-	1220	-	5,0	5,0		597	
680,22	300	370		978	1027,0	1041,0	1066	-	1220	-	5,0	5,0		597	
678,12	300	350	1000	1036	1085,0	1095,0	1122	-	1284	-	6,0	6,0		720	
678,12	300	350		1036	1085,0	1095,0	1122	-	1284	-	6,0	6,0		720	
735,23	280	330	1060	1096	1150,0	1160,0	1189	-	1364	-	6,0	6,0		850	
735,23	280	330		1096	1150,0	1160,0	1189	-	1364	-	6,0	6,0		850	
1 372,82	220	260		1098	1140,0	1150,0	-	-	1372	-	6,0	6,0		1080	
852,74	250	300	1180	1216	1275,0	1285,0	1316	-	1504	-	6,0	6,0		1050	
852,74	250	300		1216	1275,0	1285,0	1316	-	1504	-	6,0	6,0		1050	

DOUBLE ROW ROLLER BEARINGS

Design

Double row cylindrical roller bearings are suitable for applications with very high radial load and high revolution frequencies. As standard, double row cylindrical roller bearings are made in two versions (NN, NNU). These bearings are separable and are manufactured in designs with lubrication groove or without it.

Double row cylindrical roller bearings feature high rigidity and are used mostly in locations of service spindles of machine tools and similar equipment.

NN design

Double row cylindrical roller bearings of NN version have two rows of rollers guided by three flanges on inner ring. The outer ring is without flanges, and therefore these flanges cannot transfer axial forces. Double row cylindrical roller bearings of NN30K version are commonly used with cylindrical bore 1:12; if pre-agreed so, they can be supplied also with cylindrical bore.

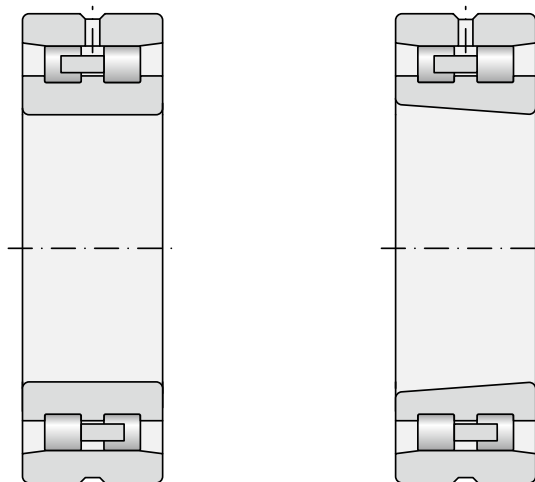

Fig. 12.4.12 (a, b)

NNU design

Double row cylindrical roller bearings of NNU49 version have three guide flanges on outer ring and smooth inner ring. Bearings can transfer radial load only. NNU4920 and NNU4924 type bearings are also supplied in tandems in compliance with technical conditions of TPF 11322. A pair coupled in this manner in location has the function of four-row cylindrical roller bearings, and suits location of rollers of rolling mills, levellers, etc. If you need tandem of different bearing dimensions, please contact the technical and consultancy services of ZKL. Double row cylindrical roller bearings in NNU design can be supplied with cylindrical or tapered bore.

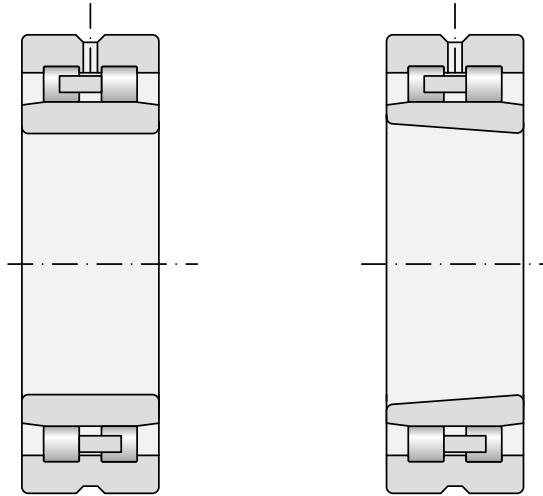

Fig. 12.4.13 (a, b)

General information

Main dimensions

The main dimensions of double row cylindrical roller bearing stated in the dimension tables comply with international dimensional plan ISO 15.

Tolerances

Double row cylindrical roller bearings are usually made in normal accuracy level P0 which is not presented. Delivery of bearings in higher accuracy levels P6, P5 and P4 has to be consulted in advance with the supplier. Tapered bore cylindrical roller bearings are only produced in high accuracy levels P5 and P4. The limit values of bearing dimension and run accuracy deviations comply with the standard ISO 492 (see chapter 7).

Radial clearance

Double row cylindrical roller bearings with cylindrical bore are made with normal radial clearance. Delivery of bearings with bigger clearance C3, C4 or C5, alternatively with smaller clearance C2, has to be consulted with the supplier. Values of radial clearances comply with the standard ISO 5753 and apply for bearings in non-assembled state. The values comply with the clearances of single row cylindrical roller bearings stated in chart 7.19.

Tapered bore cylindrical roller bearings are only produced with reduced radial clearance with mutually non-interchangeable rings C1NA and C2NA. The C1NA and C2NA symbols are combined with characters for the P5 and P4 accuracy level, e.g. P5 + C1NA is designated P51NA. Values of radial clearances comply with the standard ISO 5753 and are stated in chart 7.20.

Sliding axial movement

Double row cylindrical roller bearings are to certain extent capable of alignment of the shaft axial displacement against the body without reducing the service life of the bearing, same as single row cylindrical roller bearings (fig. 12.4.11). The values of maximum axial slide "s" are stated in the table section.

Misalignment

Misalignment of inner ring in double row cylindrical roller bearings with cylindrical bore against outer ring produces torque load in the bearing which leads to increased load and shortened service life of the bearing.

Cylindrical roller bearings with tapered bore are not suitable for applications in locations where mutual alignment of inner and outer bearing rings is not ensured.

Running temperatures

As standard, rings of double row cylindrical roller bearings are made for operation to 120 °C.

Upon request, roller bearings with stabilisation for operation to temperatures 200 °C can be supplied. In other cases please contact the technical and consultancy services.

Cages

Roller bearings are usually manufactured with massive brass cage guided on rolling elements which is usually not designated. Exception is NNU49 bearing with massive brass case M the design of which forms a part of the designation.

Special applications utilise massive steel cage guided on rolling elements; delivery of bearings with steel cages has to be discussed with the supplier.

Lubrication groove and holes on outer ring

All sizes of double row cylindrical roller bearings can be supplied with a groove and lubrication holes on outer ring (W33). This design allows supply of lubricant directly in the bearing between two rows of rollers which will ensure better lubrication of bearings and higher service reliability.

Minimum load

Minimum radial load recommended for double row ZKL cylindrical roller bearings is such that equals to 2% of the dynamic load bearing capacity of the bearing.

Equivalent dynamic load of bearing

$$P = F_r$$

Equivalent static load of bearing

$$P_0 = F_r$$

Additional designations

C1NA . . . Radial clearance of double row cylindrical roller bearings with tapered bore

C2NA . . . Radial clearance higher than C1NA of double row cylindrical roller bearings with tapered bore

W33 . . . Lubrication groove and holes on outer ring



Double row cylindrical roller bearings d = 25 to 1000 mm

d = 25 to 90 mm

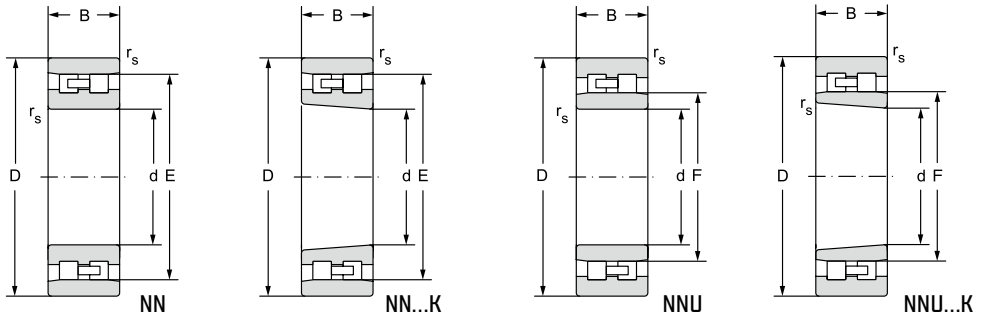

12.4.2

Main dimensions								Basic load rating		Fatigue load limit
d	D	B	r _s	r _{1s}	E	F	s ¹⁾	dynamic	static	P _u
			min	min				C _r	C _{or}	
mm								kN	kN	kN
25	47	16	1,0	1,0	41,3		1,0	21,5	23,8	2,90
	47	16	1,0	1,0	41,3		1,0	21,5	23,8	2,90
30	55	19	1,0	1,0	48,5		1,0	28,7	32,5	3,96
	55	19	1,0	1,0	48,5		1,0	28,7	32,5	3,96
35	62	20	1,0	1,0	55,0		1,0	36,9	43,8	5,34
	62	20	1,0	1,0	55,0		1,0	36,9	43,8	5,34
40	68	21	1,0	1,0	61,0		1,0	38,3	44,7	5,45
	68	21	1,0	1,0	61,0		1,0	38,3	44,7	5,45
45	75	23	1,0	1,0	67,5		1,0	44,7	53,1	6,48
	75	23	1,0	1,0	67,5		1,0	44,7	53,1	6,48
50	80	23	1,0	1,0	72,5		1,0	48,2	59,6	7,27
	80	23	1,0	1,0	72,5		1,0	48,2	59,6	7,27
55	90	26	1,1	1,1	81,0		1,2	64,3	81,0	9,88
	90	26	1,1	1,1	81,0		1,2	64,3	81,0	9,88
60	95	26	1,1	1,1	86,1		1,2	68,1	89,1	10,87
	95	26	1,1	1,1	86,1		1,2	68,1	89,1	10,87
65	100	26	1,1	1,1	91,0		1,2	70,8	98,1	11,96
	100	26	1,1	1,1	91,0		1,2	70,8	98,1	11,96
70	110	30	1,1	1,1	100,0		1,2	90,9	128,0	15,61
	110	30	1,1	1,1	100,0		1,2	90,9	128,0	15,61
75	115	30	1,1	1,1	105,0		1,2	90,9	128,0	15,61
	115	30	1,1	1,1	105,0		1,2	90,9	128,0	15,61
80	125	34	1,1	1,1	113,0		1,4	114,0	162,0	19,76
	125	34	1,1	1,1	113,0		1,4	114,0	162,0	19,76
85	130	34	1,1	1,1	118,0		1,4	119,0	178,0	21,71
	130	34	1,1	1,1	118,0		1,4	119,0	178,0	21,71
90	140	37	1,5	1,5	127,0		1,4	131,0	192,0	23,41
	140	37	1,5	1,5	127,0		1,4	131,0	192,0	23,41

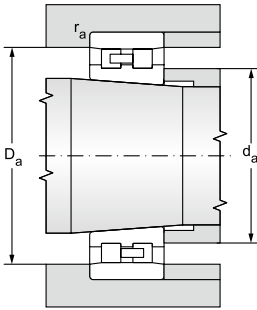

¹⁾ Admissible axial movement



Limiting speed for lubrication with		Bearing designation	Abutment and fillet dimensions						Lubrication groove and holes		Weight	
grease	oil		d	d _a	d _a	D _a	D _a	r _a	r _{1a}	a		b
min ⁻¹			mm								kg	
			min	max	min	max	max	max				
19000	22000	NN3005	25	29	-	42	43	1,0	1,0	3,2	4,8	0,12
19000	22000	NN3005K		29	-	42	43	1,0	1,0	3,2	4,8	0,12
16000	18000	NN3006	30	35	-	49	50	1,0	1,0	3,2	4,8	0,19
16000	18000	NN3006K		35	-	49	50	1,0	1,0	3,2	4,8	0,19
14000	16000	NN3007	35	40	-	56	57	1,0	1,0	3,2	4,8	0,25
14000	16000	NN3007K		40	-	56	57	1,0	1,0	3,2	4,8	0,25
12600	14000	NN3008	40	45	-	62	63	1,0	1,0	3,2	4,8	0,30
12600	14000	NN3008K		45	-	62	63	1,0	1,0	3,2	4,8	0,30
11000	12600	NN3009	45	50	-	69	70	1,0	1,0	3,2	4,8	0,38
11000	12600	NN3009K		50	-	69	70	1,0	1,0	3,2	4,8	0,38
10600	12000	NN3010	50	55	-	74	75	1,0	1,0	3,2	4,8	0,42
10600	12000	NN3010K		55	-	74	75	1,0	1,0	3,2	4,8	0,42
9400	11000	NN3011	55	62	-	82	84	1,0	1,0	3,2	4,8	0,62
9400	11000	NN3011K		62	-	82	84	1,0	1,0	3,2	4,8	0,62
8900	10000	NN3012	60	67	-	87	88	1,0	1,0	3,2	4,8	0,66
8900	10000	NN3012K		67	-	87	88	1,0	1,0	3,2	4,8	0,66
8400	9400	NN3013	65	72	-	92	93	1,0	1,0	3,2	4,8	0,71
8400	9400	NN3013K		72	-	92	93	1,0	1,0	3,2	4,8	0,71
7500	8400	NN3014	70	77	-	102	103	1,0	1,0	3,2	6,5	1,00
7500	8400	NN3014K		77	-	102	103	1,0	1,0	3,2	6,5	1,00
7100	7900	NN3015	75	82	-	107	108	1,0	1,0	3,2	6,5	1,10
7100	7900	NN3015K		82	-	107	108	1,0	1,0	3,2	6,5	1,10
6700	7500	NN3016	80	87	-	115	118	1,0	1,0	3,2	6,5	1,50
6700	7500	NN3016K		87	-	115	118	1,0	1,0	3,2	6,5	1,50
6300	7100	NN3017	85	92	-	120	123	1,0	1,0	3,2	6,5	1,60
6300	7100	NN3017K		92	-	120	123	1,0	1,0	3,2	6,5	1,60
6000	6700	NN3018	90	98	-	129	132	1,5	1,5	3,2	6,5	2,00
6000	6700	NN3018K		98	-	129	132	1,5	1,5	3,2	6,5	2,00

Double row cylindrical roller bearings

d = 95 to 160 mm

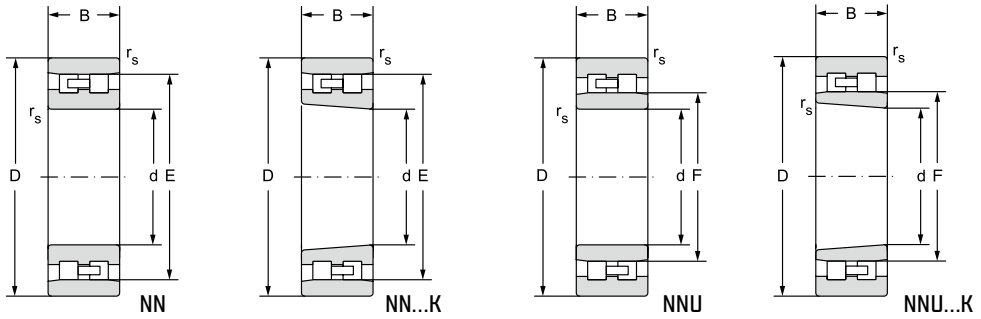

12.4.2

Main dimensions								Basic load rating		Fatigue load limit
d	D	B	r _s	r _{1s}	E	F	s ¹⁾	C _r	C _{or}	P _u
mm			min	min				kN		kN
95	145	37	1,5	1,5	132,0		1,4	139,0	207,0	25,24
	145	37	1,5	1,5	132,0		1,4	139,0	207,0	25,24
100	140	40	1,1	1,1		113,0	1,7	119,0	215,0	26,22
	140	40	1,1	1,1		113,0	1,7	119,0	215,0	26,22
	150	37	1,5	1,5	137,0		1,5	144,0	224,0	27,32
	150	37	1,5	1,5	137,0		1,5	144,0	224,0	27,32
105	145	40	1,1	1,1		117,0	1,7	161,0	315,0	23,70
	145	40	1,1	1,1		117,0	1,7	161,0	315,0	23,70
	160	41	2,0	2,0	146,0		1,5	188,0	282,0	20,85
	160	41	2,0	2,0	146,0		1,5	188,0	282,0	20,85
110	150	40	1,1	1,1		122,0	2,0	167,0	335,0	24,91
	150	40	1,1	1,1		122,0	2,0	167,0	335,0	24,91
	170	45	2,0	2,0	155,0		1,8	220,0	329,0	23,93
	170	45	2,0	2,0	155,0		1,8	220,0	329,0	23,93
120	165	40	1,1	1,1		134,5	2,2	168,0	304,0	21,99
	165	40	1,1	1,1		134,5	2,2	168,0	304,0	21,99
	180	46	2,0	2,0	165,0		2,1	228,0	355,0	25,29
	180	46	2,0	2,0	165,0		2,1	228,0	355,0	25,29
130	180	50	1,5	1,5		144,0	2,5	274,0	545,0	38,45
	180	50	1,5	1,5		144,0	2,5	274,0	545,0	38,45
	200	52	2,0	2,0	182,0		2,4	282,0	447,0	30,95
	200	52	2,0	2,0	182,0		2,4	282,0	447,0	30,95
140	190	50	1,5	1,5		154,0	2,7	283,0	585,0	40,50
	190	50	1,5	1,5		154,0	2,7	283,0	585,0	40,50
	210	53	2,0	2,0	192,0		2,8	299,0	482,0	32,79
	210	53	2,0	2,0	192,0		2,8	299,0	482,0	32,79
150	210	60	2,0	2,0		167,0	2,8	350,0	715,0	48,23
	210	60	2,0	2,0		167,0	2,8	350,0	715,0	48,23
	225	56	2,1	2,1	206,0		3,0	322,0	521,0	34,71
	225	56	2,1	2,1	206,0		3,0	322,0	521,0	34,71
160	220	60	2,0	2,0		177,0	3,3	365,0	760,0	50,44
	220	60	2,0	2,0		177,0	3,3	365,0	760,0	50,44
	240	60	2,1	2,1	219,0		3,5	375,0	660,0	43,13
	240	60	2,1	2,1	219,0		3,5	375,0	660,0	43,13

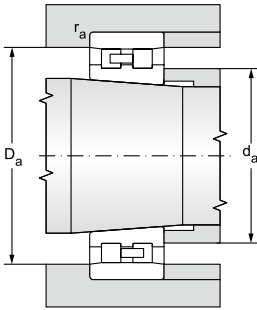

¹⁾ Admissible axial movement



Limiting speed for lubrication with		Bearing designation	Abutment and fillet dimensions						Lubrication groove and holes		Weight	
grease	oil		d	d _a	d _a	D _a	D _a	r _a	r _{1a}	a		b
min ⁻¹			mm								kg	
			min	max	min	max	max	max				
5600	6300	NN3019	95	103	-	134	137	1,5	1,5	3,2	6,5	2,10
5600	6300	NN3019K		103	-	134	137	1,5	1,5	3,2	6,5	2,10
3800	4700	NUU4920M	100	106	112	-	134	1,0	1,0	3,2	6,5	1,92
3800	4700	NUU4920KM		106	112	-	134	1,0	1,0	3,2	6,5	1,92
5300	6000	NN3020		108	-	139	142	1,5	1,5	3,2	6,5	2,20
5300	6000	NN3020K		108	-	139	142	1,5	1,5	3,2	6,5	2,20
3800	4800	NUU4921M	105	111,5	116	-	138,5	1,0	1,0	3,2	6,5	1,99
3800	4800	NUU4921KM		111,5	116	-	138,5	1,0	1,0	3,2	6,5	1,99
5000	5600	NN3021		114	-	148	151	2,0	2,0	3,2	6,5	2,80
5000	5600	NN3021K		114	-	148	151	2,0	2,0	3,2	6,5	2,80
3600	4500	NUU4922M	110	116,5	121	-	143,5	1,0	1,0	3,2	6,5	2,07
3600	4500	NUU4922KM		116,5	121	-	143,5	1,0	1,0	3,2	6,5	2,07
4700	5300	NN3022		119	-	157	161	2,0	2,0	3,2	6,5	3,55
4700	5300	NN3022K		119	-	157	161	2,0	2,0	3,2	6,5	3,55
3200	4000	NUU4924M	120	126	134	-	159	1,0	1,0	3,2	6,5	2,81
3200	4000	NUU4924KM		126	134	-	159	1,0	1,0	3,2	6,5	2,81
4500	5000	NN3024		129	-	167	171	2,0	2,0	3,2	6,5	3,85
4500	5000	NN3024K		129	-	167	171	2,0	2,0	3,2	6,5	3,85
3000	3800	NUU4926M	130	138	143	-	172	1,5	1,5	3,2	6,5	3,85
3000	3800	NUU4926KM		138	143	-	172	1,5	1,5	3,2	6,5	3,85
4000	4500	NN3026		139	-	184	191	2,0	2,0	4,8	9,5	5,75
4000	4500	NN3026K		139	-	184	191	2,0	2,0	4,8	9,5	5,75
2800	3600	NUU4928M	140	148	153	-	182	1,5	1,5	3,2	6,5	4,08
2800	3600	NUU4928KM		148	153	-	182	1,5	1,5	3,2	6,5	4,08
3800	4200	NN3028		150	-	194	200	2,0	2,0	4,8	9,5	6,20
3800	4200	NN3028K		150	-	194	200	2,0	2,0	4,8	9,5	6,20
2600	3200	NUU4930M	150	159	166	-	201	2,0	2,0	3,2	6,5	6,39
2600	3200	NUU4930KM		159	166	-	201	2,0	2,0	3,2	6,5	6,39
3500	4000	NN3030		162	-	208	213	2,0	2,0	4,8	9,5	7,50
3500	4000	NN3030K		162	-	208	213	2,0	2,0	4,8	9,5	7,50
2400	3000	NUU4932M	160	169	176	-	211	2,0	2,0	3,2	6,5	6,76
2400	3000	NUU4932KM		169	176	-	211	2,0	2,0	3,2	6,5	6,76
2400	2800	NN3032		171	-	222	229	2,0	2,0	4,8	9,5	9,41
2400	2800	NN3032K		171	-	222	229	2,0	2,0	4,8	9,5	9,41

Double row cylindrical roller bearings

d = 170 to 280 mm

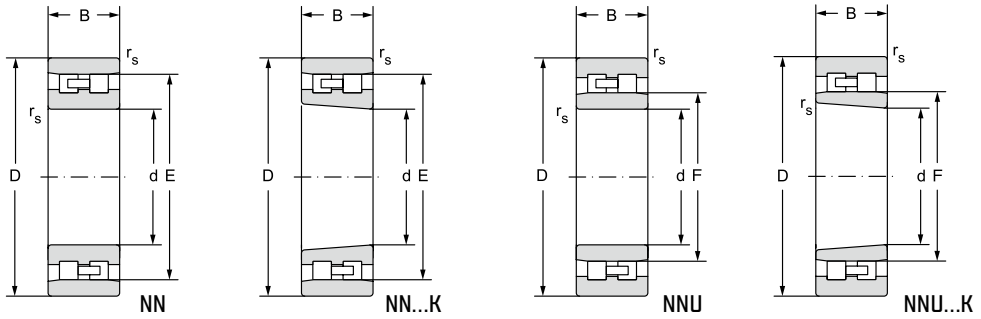

d	Main dimensions							Basic load rating		Fatigue load limit
	D	B	r _s	r _{1s}	E	F	s ¹⁾	C _r	C _{or}	P _u
	mm	mm	min	min	mm	mm	mm	kN	kN	kN
170	230	60	2,0	2,0		187,0	3,9	375,0	805,0	52,61
	230	60	2,0	2,0		187,0	3,9	375,0	805,0	52,61
	260	67	2,1	2,1	236,0		4,1	450,0	805,0	51,48
	260	67	2,1	2,1	236,0		4,1	450,0	805,0	51,48
180	250	69	2,0	2,0		200,0	4,5	480,0	1020,0	65,23
	250	69	2,0	2,0		200,0	4,5	480,0	1020,0	65,23
	280	74	2,1	2,1	255,0		4,5	565,0	995,0	62,36
	280	74	2,1	2,1	255,0		4,5	565,0	995,0	62,36
190	260	69	2,0	2,0		211,5	4,5	485,0	1060,0	66,87
	260	69	2,0	2,0		211,5	4,5	485,0	1060,0	66,87
	290	75	2,1	2,1	265,0		4,6	595,0	1080,0	66,82
	290	75	2,1	2,1	265,0		4,6	595,0	1080,0	66,82
200	280	80	2,1	2,1		223,0	5,0	570,0	1220,0	75,49
	280	80	2,1	2,1		223,0	5,0	570,0	1220,0	75,49
	310	82	2,1	2,1	282,0		5,2	655,0	1170,0	71,09
	310	82	2,1	2,1	282,0		5,2	655,0	1170,0	71,09
220	300	60	3,5	3,5	278,0		2,0	299,0	668,0	40,35
	300	80	2,1	2,1		243,0	5,0	600,0	1330,0	80,34
	300	80	2,1	2,1		243,0	5,0	600,0	1330,0	80,34
	340	90	3,0	3,0	310,0		5,4	815,0	1480,0	87,43
	340	90	3,0	3,0	310,0		5,4	815,0	1480,0	87,43
240	320	60	3,5	3,5	298,0		2,0	316,0	750,0	44,31
	320	80	2,1	2,1		263,0	5,4	625,0	1450,0	85,66
	320	80	2,1	2,1		263,0	5,4	625,0	1450,0	85,66
	360	92	3,0	3,0	330,0		5,7	855,0	1600,0	92,59
	360	92	3,0	3,0	330,0		5,7	855,0	1600,0	92,59
260	360	100	2,1	2,1		289,0	6,0	935,0	2100,0	120,33
	360	100	2,1	2,1		289,0	6,0	935,0	2100,0	120,33
	400	104	4,0	4,0	364,0		6,2	1030,0	1920,0	107,97
	400	104	4,0	4,0	364,0		6,2	1030,0	1920,0	107,97
280	380	100	2,1	2,1		309,0	6,0	960,0	2230,0	125,41
	380	100	2,1	2,1		309,0	6,0	960,0	2230,0	125,41
	420	106	4,0	4,0	384,0		6,7	1100,0	2000,0	110,50
	420	106	4,0	4,0	384,0		6,7	1100,0	2000,0	110,50

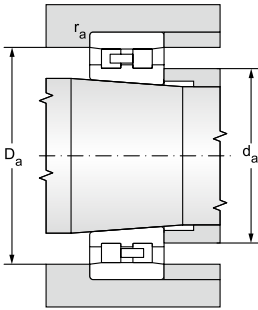

¹⁾ Admissible axial movement



Limiting speed for lubrication with		Bearing designation	Abutment and fillet dimensions						Lubrication groove and holes		Weight	
grease	oil		d	d _a	d _a	D _a	D _a	r _a	r _{1a}	a		b
min ⁻¹			mm								kg	
2400	2800	NNU4934M	170	179	186	-	221	2,0	2,0	3,2	6,5	7,12
2400	2800	NNU4934KM		179	186	-	221	2,0	2,0	3,2	6,5	7,12
2200	2600	NN3034		181	-	239	249	2,0	2,0	4,8	9,5	12,8
2200	2600	NN3034K		181	-	239	249	2,0	2,0	4,8	9,5	12,8
2200	2600	NNU4936M	180	189	199	-	241	2,0	2,0	4,8	9,5	10,4
2200	2600	NNU4936KM		189	199	-	241	2,0	2,0	4,8	9,5	10,4
2000	2400	NN3036		191	-	258	269	2,0	2,0	6,0	11,1	16,8
2000	2400	NN3036K		191	-	258	269	2,0	2,0	6,0	11,1	16,8
2000	2600	NNU4938M	190	199	211	-	251	2,0	2,0	4,8	9,5	10,9
2000	2600	NNU4938KM		199	211	-	251	2,0	2,0	4,8	9,5	10,9
2000	2400	NN3038		201	-	268	279	2,0	2,0	6,0	11,1	17,8
2000	2400	NN3038K		201	-	268	279	2,0	2,0	6,0	11,1	17,8
1900	2400	NNU4940M	200	211	222	-	269	2,0	2,0	6,0	11,1	15,3
1900	2400	NNU4940KM		211	222	-	269	2,0	2,0	6,0	11,1	15,3
1800	2200	NN3040		211	-	285	299	2,0	2,0	6,0	11,1	22,7
1800	2200	NN3040K		211	-	285	299	2,0	2,0	6,0	11,1	22,7
1800	2200	NN3944	220	-	-	-	-	4,0	4,0	-	-	12,0
1700	2200	NNU4944M		231	242	-	289	2,0	2,0	6,0	11,1	16,6
1700	2200	NNU4944KM		231	242	-	289	2,0	2,0	6,0	11,1	16,6
1700	2000	NN3044		233	-	313	327	2,5	2,5	7,5	13,9	29,6
1700	2000	NN3044K		233	-	313	327	2,5	2,5	7,5	13,9	29,6
1600	2000	NN3948	240	-	-	-	-	2,0	2,0	-	-	13,0
1600	2000	NNU4948M		251	262	-	309	2,0	2,0	6,0	11,1	18,0
1600	2000	NNU4948KM		251	262	-	309	2,0	2,0	6,0	11,1	18,0
1500	1800	NN3048		253	-	334	347	2,5	2,5	7,5	13,9	32,7
1500	1800	NN3048K		253	-	334	347	2,5	2,5	7,5	13,9	32,7
1400	1800	NNU4952M	260	271	288	-	349	2,0	2,0	7,5	13,9	31,1
1400	1800	NNU4952KM		271	288	-	349	2,0	2,0	7,5	13,9	31,1
1400	1700	NN3052		276	-	368	384	3,0	3,0	7,5	13,9	47,7
1400	1700	NN3052K		276	-	368	384	3,0	3,0	7,5	13,9	47,7
1300	1700	NNU4956M	280	291	308	-	369	2,0	2,0	7,5	13,9	33,0
1300	1700	NNU4956KM		291	308	-	369	2,0	2,0	7,5	13,9	33,0
1300	1600	NN3056		298	-	388	402	3,0	3,0	7,5	13,9	49,6
1300	1600	NN3056K		298	-	388	402	3,0	3,0	7,5	13,9	49,6

Double row cylindrical roller bearings

$d = 300$ to 400 mm

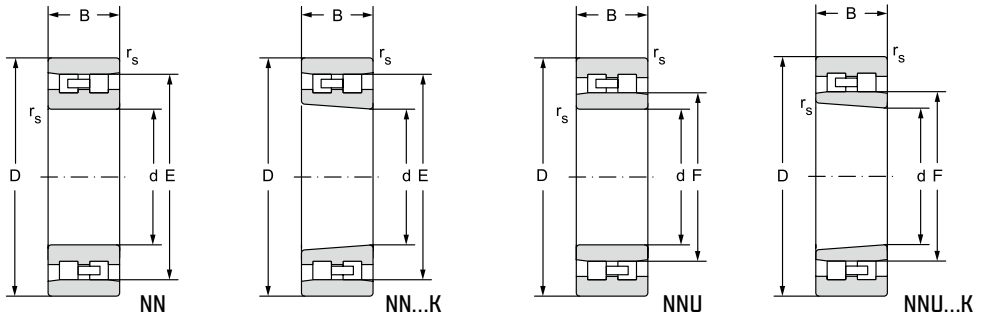

12.4.2

Main dimensions								Basic load rating		Fatigue load limit
d	D	B	r_s	r_{1s}	E	F	$s^{1)}$	dynamic	static	P_u
								C_r	C_{or}	
mm			min	min				kN		kN
300	420	118	3,0	3,0		336,0	6,0	1230,0	2870,0	157,24
	420	118	3,0	3,0		336,0	6,0	1230,0	2870,0	157,24
	460	118	4,0	4,0	418,0		7,0	1290,0	2460,0	132,61
	460	118	4,0	4,0	418,0		7,0	1290,0	2460,0	132,61
320	440	118	3,0	3,0		356,0	7,0	1260,0	3050,0	164,41
	440	118	3,0	3,0		356,0	7,0	1260,0	3050,0	164,41
	480	121	5,0	5,0	438,0		8,0	1360,0	2510,0	133,24
	480	121	5,0	5,0	438,0		8,0	1360,0	2510,0	133,24
340	460	118	3,0	3,0		379,0	5,0	1050,0	2600,0	138,01
	460	118	3,0	3,0		379,0	5,0	1050,0	2600,0	138,01
	520	133	6,0	6,0	473,0		9,0	1680,0	3100,0	161,02
	520	133	6,0	6,0	473,0		9,0	1680,0	3100,0	161,02
	580	243	5,0	5,0		402,0	10,0	4000,0	7400,0	376,68
	580	243	5,0	5,0		402,0	10,0	4000,0	7400,0	376,68
360	480	118	3,0	3,0		399,0	5,0	1100,0	2700,0	141,24
	480	118	3,0	3,0		399,0	5,0	1100,0	2700,0	141,24
	540	134	6,0	6,0	493,0		9,0	1740,0	3350,0	171,65
	540	134	6,0	6,0	493,0		9,0	1740,0	3350,0	171,65
	600	243	5,0	5,0		422,0	5,9	4250,0	8300,0	417,13
	600	243	5,0	5,0		422,0	5,9	4250,0	8300,0	417,13
380	520	140	4,0	4,0		426,0	5,5	1350,0	3500,0	179,34
	520	140	4,0	4,0		426,0	5,5	1350,0	3500,0	179,34
	560	180	5,0	5,0		425,0	7,3	2800,0	5800,0	293,34
	560	180	5,0	5,0		425,0	7,3	2800,0	5800,0	293,34
	620	243	5,0	5,0		442,0	7,4	4200,0	8500,0	421,98
	620	243	5,0	5,0		442,0	7,4	4200,0	8500,0	421,98
400	540	140	4,0	4,0		446,0	5,5	1400,0	3650,0	184,60
	540	140	4,0	4,0		446,0	5,5	1400,0	3650,0	184,60
	600	200	5,0	5,0		449,0	7,9	3400,0	7100,0	352,48
	600	200	5,0	5,0		449,0	7,9	3400,0	7100,0	352,48
	650	250	6,0	6,0		463,0	7,5	4600,0	9500,0	464,78
	650	250	6,0	6,0		463,0	7,5	4600,0	9500,0	464,78

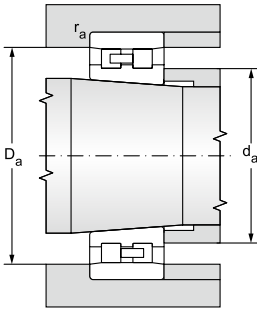

¹⁾ Admissible axial movement
Bearings in the new standard NEW FORCE



Limiting speed for lubrication with		Bearing designation	Abutment and fillet dimensions						Lubrication groove and holes		Weight	
grease	oil		d	d _a	d _a	D _a	D _a	r _a	r _{1a}	a		b
min ⁻¹			mm								kg	
			min	max	min	max	max	max				
1200	1500	NNU4960M	300	313	335	-	407	2,5	2,5	9,0	16,7	51,9
1200	1500	NNU4960KM		313	335	-	407	2,5	2,5	9,0	16,7	51,9
1200	1400	NN3060		316	-	422	444	3,0	3,0	9,0	16,7	70,7
1200	1400	NN3060K		316	-	422	444	3,0	3,0	9,0	16,7	70,7
1100	1400	NNU4964M	320	333	355	-	427	2,5	2,5	9,0	16,7	54,9
1100	1400	NNU4964KM		333	355	-	427	2,5	2,5	9,0	16,7	54,9
1200	1400	NN3064		338	-	442	462	3,0	3,0	9,0	16,7	74,2
1200	1400	NN3064K		338	-	442	462	3,0	3,0	9,0	16,7	74,2
1500	1800	NNU4968M	340	352	378	-	448	2,5	2,5	9,0	16,7	55,6
1500	1800	NNU4968KM		352	378	-	448	2,5	2,5	9,0	16,7	55,6
1100	1300	NN3068		362	-	477	498	4,0	4,0	9,0	16,7	99,0
1100	1300	NN3068K		362	-	477	498	4,0	4,0	9,0	16,7	99,0
800	950	NNU4168M		360	392	-	560	4,0	4,0	9,0	16,7	260
800	950	NNU4168KM		360	392	-	560	4,0	4,0	9,0	16,7	260
1500	1800	NNU4972M	360	372	398	-	468	2,5	2,5	9,0	16,7	57,5
1500	1800	NNU4972KM		372	398	-	468	2,5	2,5	9,0	16,7	57,5
1000	1200	NN3072		382	-	497	518	4,0	4,0	9,0	16,7	105
1000	1200	NN3072K		382	-	497	518	4,0	4,0	9,0	16,7	105
750	900	NNU4172M		380	414	-	580	4,0	4,0	9,0	16,7	275
750	900	NNU4172KM		380	414	-	580	4,0	4,0	9,0	16,7	275
1400	1700	NNU4976M	380	395	425	-	505	3,0	3,0	9,0	16,7	86,0
1400	1700	NNU4976KM		395	425	-	505	3,0	3,0	9,0	16,7	86,0
850	1000	NNU4076M		400	417	-	540	4,0	4,0	9,0	16,7	150
850	1000	NNU4076KM		400	417	-	540	4,0	4,0	9,0	16,7	150
720	850	NNU4176M		400	434	-	600	4,0	4,0	9,0	16,7	285
720	850	NNU4176KM		400	434	-	600	4,0	4,0	9,0	16,7	285
1300	1600	NNU4980M**	400	415	445	-	525	3,0	3,0	9,0	16,7	91,0
1300	1600	NNU4980KM**		415	445	-	525	3,0	3,0	9,0	16,7	91,0
800	950	NNU4080M**		420	440	-	580	4,0	4,0	9,0	16,7	205
800	950	NNU4080KM**		420	440	-	580	4,0	4,0	9,0	16,7	205
680	800	NNU4180M**		426	456	-	624	5,0	5,0	9,0	16,7	325
680	800	NNU4180KM**		426	456	-	624	5,0	5,0	9,0	16,7	325

Double row cylindrical roller bearings

d = 420 to 530 mm

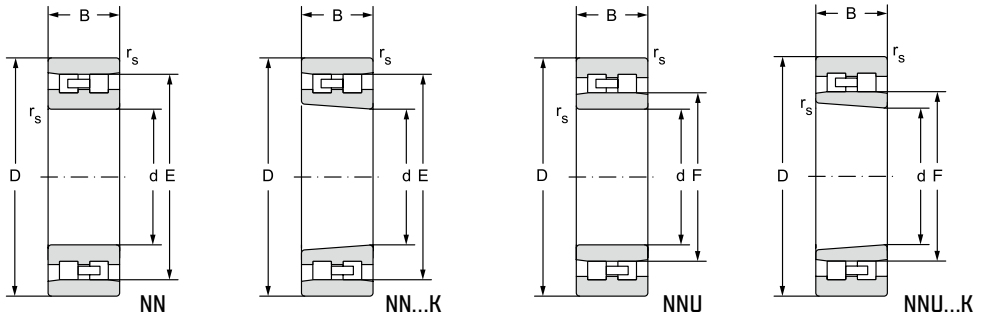

12.4.2

Main dimensions								Basic load rating		Fatigue load limit
d	D	B	r _s	r _{1s}	E	F	s ¹⁾	dynamic	static	P _u
								C _r	C _{or}	
mm			min	min				kN		kN
420	560	140	4,0	4,0		466,0	5,5	1460,0	3800,0	189,80
	560	140	4,0	4,0		466,0	5,5	1460,0	3800,0	189,80
	620	200	5,0	5,0		469,0	7,8	3500,0	7500,0	367,98
	620	200	5,0	5,0		469,0	7,8	3500,0	7500,0	367,98
	700	280	6,0	6,0		497,0	12,2	5300,0	11300,0	542,24
	700	280	6,0	6,0		497,0	12,2	5300,0	11300,0	542,24
440	600	160	4,0	4,0		490,0	5,8	1950,0	5000,0	245,32
	600	160	4,0	4,0		490,0	5,8	1950,0	5000,0	245,32
	650	157	8,0	8,0	596,0		13,0	2460,0	4920,0	238,02
	650	157	8,0	8,0	596,0		13,0	2460,0	4920,0	238,02
	650	212	6,0	6,0		487,0	9,6	3800,0	8200,0	396,70
	650	212	6,0	6,0		487,0	9,6	3800,0	8200,0	396,70
	720	280	6,0	6,0		511,0	10,8	5600,0	11800,0	560,30
	720	280	6,0	6,0		511,0	10,8	5600,0	11800,0	560,30
460	620	160	4,0	4,0		510,0	5,8	2000,0	5350,0	259,54
	620	160	4,0	4,0		510,0	5,8	2000,0	5350,0	259,54
	680	218	6,0	6,0		513,0	7,7	4100,0	9300,0	443,90
	680	218	6,0	6,0		513,0	7,7	4100,0	9300,0	443,90
	760	300	7,5	7,5		537,0	12,8	6200,0	12300,0	575,27
	760	300	7,5	7,5		537,0	12,8	6200,0	12300,0	575,27
480	650	170	5,0	5,0		534,0	6,0	2200,0	6000,0	287,15
	650	170	5,0	5,0		534,0	6,0	2200,0	6000,0	287,15
	700	218	6,0	6,0		533,0	7,5	4200,0	9600,0	453,51
	700	218	6,0	6,0		533,0	7,5	4200,0	9600,0	453,51
	790	308	7,5	7,5		557,0	12,0	6500,0	12700,0	586,87
	790	308	7,5	7,5		557,0	12,0	6500,0	12700,0	586,87
500	670	170	5,0	5,0		554,0	6,0	2200,0	6000,0	284,17
	670	170	5,0	5,0		554,0	6,0	2200,0	6000,0	284,17
	720	218	6,0	6,0		553,0	7,5	4300,0	9800,0	458,35
	720	218	6,0	6,0		553,0	7,5	4300,0	9800,0	458,35
	830	325	7,5	7,5		582,0	14,0	7200,0	14500,0	660,83
	830	325	7,5	7,5		582,0	14,0	7200,0	14500,0	660,83
530	780	250	6,0	6,0		591,0	10,0	5200,0	11900,0	544,81
	780	250	6,0	6,0		591,0	10,0	5200,0	11900,0	544,81
	870	335	7,5	7,5		618,0	17,0	7500,0	15500,0	695,62
	870	335	7,5	7,5		618,0	17,0	7500,0	15500,0	695,62

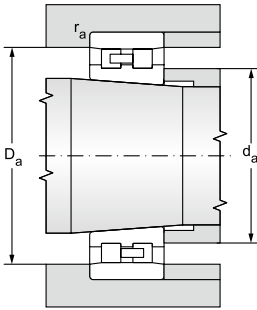

¹⁾ Admissible axial movement
Bearings in the new standard NEW FORCE



Limiting speed for lubrication with		Bearing designation	Abutment and fillet dimensions						Lubrication groove and holes		Weight	
grease	oil		d	d _a	d _a	D _a	D _a	r _a	r _{1a}	a		b
min ⁻¹			mm								kg	
1300	1600	NNU4984M**	420	435	465	-	545	3,0	3,0	9,0	16,7	94,0
1300	1600	NNU4984KM**		435	465	-	545	3,0	3,0	9,0	16,7	94,0
750	900	NNU4084M**		440	460	-	600	4,0	4,0	9,0	16,7	185
750	900	NNU4084KM**		440	460	-	600	4,0	4,0	9,0	16,7	185
630	750	NNU4184M**		446	480	-	674	5,0	5,0	9,0	16,7	440
630	750	NNU4184KM**		446	480	-	674	5,0	5,0	9,0	16,7	440
1200	1500	NNU4988M**	440	455	489	-	585	3,0	3,0	9,0	16,7	131
1200	1500	NNU4988KM**		455	489	-	585	3,0	3,0	9,0	16,7	131
750	890	NN3088**		468	-	602	622	5,0	5,0	12,0	22,3	169
750	890	NN3088K**		468	-	602	622	5,0	5,0	12,0	22,3	169
720	850	NNU4088M**		466	477	-	624	5,0	5,0	9,0	16,7	215
720	850	NNU4088KM**		466	477	-	624	5,0	5,0	9,0	16,7	215
590	700	NNU4188M**		466	500	-	694	5,0	5,0	12,0	22,3	450
590	700	NNU4188KM**		466	500	-	694	5,0	5,0	12,0	22,3	450
1100	1400	NNU4992M**	460	475	509	-	605	3,0	3,0	9,0	16,7	134
1100	1400	NNU4992KM**		475	509	-	605	3,0	3,0	9,0	16,7	134
680	800	NNU4092M**		486	503	-	654	5,0	5,0	12,0	22,3	240
680	800	NNU4092KM**		486	503	-	654	5,0	5,0	12,0	22,3	240
570	670	NNU4192M**		493	526	-	727	6,0	6,0	12,0	22,3	535
570	670	NNU4192KM**		493	526	-	727	6,0	6,0	12,0	22,3	535
1100	1400	NNU4996M**	480	497	533	-	633	4,0	4,0	9,0	16,7	160
1100	1400	NNU4996KM**		497	533	-	633	4,0	4,0	9,0	16,7	160
630	750	NNU4096M**		506	523	-	674	5,0	5,0	12,0	22,3	275
630	750	NNU4096KM**		506	523	-	674	5,0	5,0	12,0	22,3	275
530	630	NNU4196M**		513	545	-	757	6,0	6,0	12,0	22,3	590
530	630	NNU4196KM**		513	545	-	757	6,0	6,0	12,0	22,3	590
1000	1300	NNU49/500M**	500	517	553	-	653	4,0	4,0	9,0	16,7	162
1000	1300	NNU49/500KM**		517	553	-	653	4,0	4,0	9,0	16,7	162
630	750	NNU40/500M**		526	543	-	694	5,0	5,0	12,0	22,3	285
630	750	NNU40/500KM**		526	543	-	694	5,0	5,0	12,0	22,3	285
510	600	NNU41/500M**		533	568	-	797	6,0	6,0	12,0	22,3	710
510	600	NNU41/500KM**		533	568	-	797	6,0	6,0	12,0	22,3	710
570	670	NNU40/530M**	530	556	580	-	754	5,0	5,0	12,0	22,3	420
570	670	NNU40/530KM**		556	580	-	754	5,0	5,0	12,0	22,3	420
470	560	NNU41/530M**		563	604	-	837	6,0	6,0	12,0	22,3	790
470	560	NNU41/530KM**		563	604	-	837	6,0	6,0	12,0	22,3	790

Double row cylindrical roller bearings

d = 560 to 850 mm

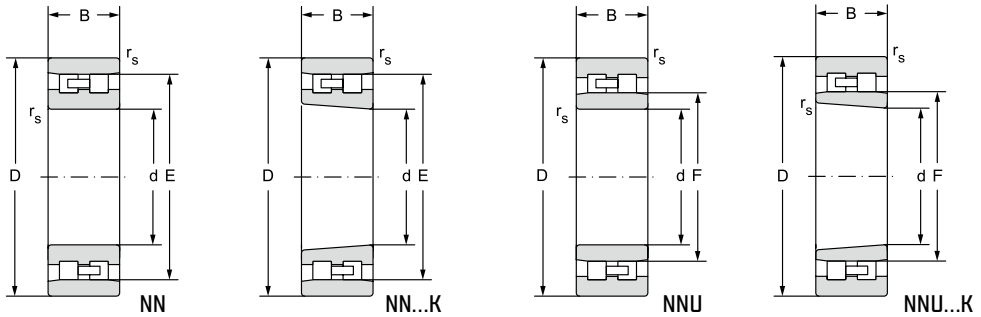

12.4.2

Main dimensions								Basic load rating		Fatigue load limit
d	D	B	r _s	r _{1s}	E	F	s ¹⁾	dynamic	static	P _u
			min	min				C _r	C _{or}	
mm								kN		kN
560	820	258	6,0	6,0		626,0	12,5	5600,0	12500,0	563,41
	820	258	6,0	6,0		626,0	12,5	5600,0	12500,0	563,41
	920	355	7,5	7,5		653,0	16,5	8500,0	18000,0	794,46
	920	355	7,5	7,5		653,0	16,5	8500,0	18000,0	794,46
600	870	272	6,0	6,0		664,0	9,2	6400,0	15100,0	667,82
	870	272	6,0	6,0		664,0	9,2	6400,0	15100,0	667,82
	980	375	7,5	7,5		699,0	18,0	9500,0	20500,0	887,23
	980	375	7,5	7,5		699,0	18,0	9500,0	20500,0	887,23
630	850	218	8,0	8,0		704,0	5,0	3910,0	10200,0	450,19
	850	218	8,0	8,0		704,0	5,0	3910,0	10200,0	450,19
	920	290	7,5	7,5		699,0	10,0	7400,0	17200,0	748,70
	920	290	7,5	7,5		699,0	10,0	7400,0	17200,0	748,70
	1030	400	7,5	7,5		734,0	19,5	10400,0	23300,0	993,57
	1030	400	7,5	7,5		734,0	19,5	10400,0	23300,0	993,57
670	980	308	7,5	7,5		744,0	11,5	8100,0	19100,0	815,95
	980	308	7,5	7,5		744,0	11,5	8100,0	19100,0	815,95
	1090	412	7,5	7,5		774,0	19,0	11900,0	25000,0	1 047,52
	1090	412	7,5	7,5		774,0	19,0	11900,0	25000,0	1 047,52
710	1030	315	7,5	7,5		784,0	10,5	9000,0	21000,0	882,94
	1030	315	7,5	7,5		784,0	10,5	9000,0	21000,0	882,94
	1150	438	9,5	9,5		820,0	20,0	13000,0	28000,0	1 153,93
	1150	438	9,5	9,5		820,0	20,0	13000,0	28000,0	1 153,93
750	1090	335	7,5	7,5		830,0	13,5	9900,0	23500,0	971,63
	1090	335	7,5	7,5		830,0	13,5	9900,0	23500,0	971,63
	1220	475	9,5	9,5		871,0	19,0	15500,0	34900,0	1 413,72
	1220	475	9,5	9,5		871,0	19,0	15500,0	34900,0	1 413,72
800	1150	345	7,5	7,5		885,0	16,0	10300,0	25500,0	1 036,11
	1150	345	7,5	7,5		885,0	16,0	10300,0	25500,0	1 036,11
	1280	475	9,5	9,5		921,0	18,5	15900,0	36000,0	1 434,70
	1280	475	9,5	9,5		921,0	18,5	15900,0	36000,0	1 434,70
850	1220	365	7,5	7,5		940,0	18,0	11200,0	28000,0	1 117,49
	1220	365	7,5	7,5		940,0	18,0	11200,0	28000,0	1 117,49
	1360	500	12,0	6,0		976,0	21,5	19000,0	44000,0	1 721,92
	1360	500	12,0	12,0		976,0	21,5	19000,0	44000,0	1 721,92

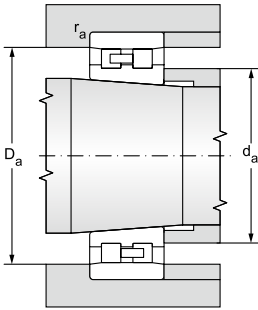

¹⁾ Admissible axial movement
Bearings in the new standard NEW FORCE



Limiting speed for lubrication with		Bearing designation	Abutment and fillet dimensions						Lubrication groove and holes		Weight	
grease	oil		d	d _a	d _a	D _a	D _a	r _a	r _{1a}	a		b
min ⁻¹			mm								kg	
530	630	NNU40/560M**	560	586	615	-	794	5,0	5,0	12,0	22,3	475
530	630	NNU40/560KM**		586	615	-	794	5,0	5,0	12,0	22,3	475
450	530	NNU41/560M**		593	638	-	887	6,0	6,0	12,0	22,3	930
450	530	NNU41/560KM**		593	638	-	887	6,0	6,0	12,0	22,3	930
510	600	NNU40/600M**	600	626	653	-	844	5,0	5,0	12,0	22,3	530
510	600	NNU40/600KM**		626	653	-	844	5,0	5,0	12,0	22,3	530
400	480	NNU41/600M**		634	682	-	946	6,0	6,0	12,0	22,3	1100
400	480	NNU41/600KM**		634	682	-	946	6,0	6,0	12,0	22,3	1100
470	600	NNU49/630M**	630	664	694	-	818	6,0	6,0	12,0	22,3	363
470	600	NNU49/630KM**		664	694	-	818	6,0	6,0	12,0	22,3	363
470	560	NNU40/630M**		664	688	-	886	6,0	6,0	12,0	22,3	635
470	560	NNU40/630KM**		664	688	-	886	6,0	6,0	12,0	22,3	635
380	450	NNU41/630M**		664	716	-	996	6,0	6,0	12,0	22,3	1330
380	450	NNU41/630KM**		664	716	-	996	6,0	6,0	12,0	22,3	1330
420	500	NNU40/670M**	670	704	733	-	946	6,0	6,0	12,0	22,3	765
420	500	NNU40/670KM**		704	733	-	946	6,0	6,0	12,0	22,3	765
360	430	NNU41/670M**		704	756	-	1056	6,0	6,0	12,0	22,3	1500
360	430	NNU41/670KM**		704	756	-	1056	6,0	6,0	12,0	22,3	1500
400	480	NNU40/710M**	710	744	772	-	996	6,0	6,0	12,0	22,3	850
400	480	NNU40/710KM**		744	772	-	996	6,0	6,0	12,0	22,3	850
320	380	NNU41/710M**		750	800	-	1110	8,0	8,0	12,0	22,3	1790
320	380	NNU41/710KM**		750	800	-	1110	8,0	8,0	12,0	22,3	1790
360	430	NNU40/750M**	750	784	816	-	1056	6,0	6,0	12,0	22,3	930
360	430	NNU40/750KM**		784	816	-	1056	6,0	6,0	12,0	22,3	930
320	380	NNU41/750M**		790	850	-	1180	8,0	8,0	12,0	22,3	2230
320	380	NNU41/750KM**		790	850	-	1180	8,0	8,0	12,0	22,3	2230
340	400	NNU40/800M**	800	833	871	-	1117	6,0	6,0	12,0	22,3	1140
340	400	NNU40/800KM**		833	871	-	1117	6,0	6,0	12,0	22,3	1140
270	320	NNU41/800M**		840	900	-	1240	8,0	8,0	12,0	22,3	2390
270	320	NNU41/800KM**		840	900	-	1240	8,0	8,0	12,0	22,3	2390
300	360	NNU40/850M**	850	883	923	-	1187	6,0	6,0	12,0	22,3	1340
300	360	NNU40/850KM**		883	923	-	1187	6,0	6,0	12,0	22,3	1340
250	300	NNU41/850M**		897	935	-	1334	10,0	5,0	12,0	22,3	2900
250	300	NNU41/850KM**		897	935	-	1334	10,0	10,0	12,0	22,3	2900

Double row cylindrical roller bearings

d = 900 to 1000 mm

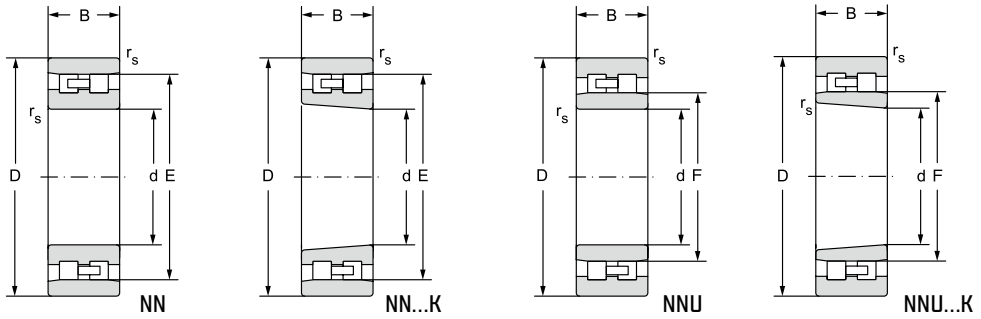

Main dimensions								Basic load rating		Fatigue load limit
d	D	B	r _s	r _{1s}	E	F	s ¹⁾	C _r	C _{or}	P _u
mm			min	min				kN		kN
900	1280	375	7,5	7,5		990,0	17,0	12000,0	30800,0	1 210,29
	1280	375	7,5	7,5		990,0	17,0	12000,0	30800,0	1 210,29
	1420	515	12,0	6,0		1032,0	27,5	21400,0	47000,0	1 812,71
	1420	515	12,0	12,0		1032,0	27,5	21400,0	47000,0	1 812,71
950	1360	412	7,5	7,5		1050,0	20,0	13700,0	34800,0	1 343,92
	1360	412	7,5	7,5		1050,0	20,0	13700,0	34800,0	1 343,92
	1500	545	12,0	6,0		1092,0	22,5	24800,0	56000,0	2 124,79
	1500	545	12,0	12,0		1092,0	22,5	24800,0	56000,0	2 124,79
1000	1320	315	7,5	7,5	1238,0		9,5	8200,0	25000,0	964,21
	1320	315	7,5	7,5	1238,0		9,5	8200,0	25000,0	964,21
	1420	412	7,5	7,5		1101,0	19,5	15000,0	37100,0	1 412,88
	1420	412	7,5	7,5		1101,0	19,5	15000,0	37100,0	1 412,88
	1580	580	12,0	6,0		1154,0	28,0	26900,0	60800,0	2 271,41
	1580	580	12,0	12,0		1154,0	28,0	26900,0	60800,0	2 271,41

12.4.2

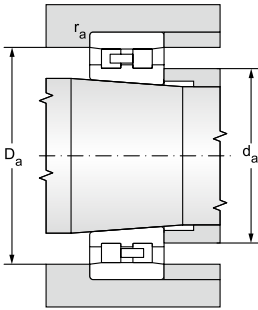

¹⁾ Admissible axial movement
Bearings in the new standard NEW FORCE



Limiting speed for lubrication with		Bearing designation	Abutment and fillet dimensions						Lubrication groove and holes		Weight	
grease	oil		d	d _a	d _a	D _a	D _a	r _a	r _{1a}	a		b
min ⁻¹			mm								kg	
280	340	NNU40/900M**	900	933	963	-	1257	6,0	6,0	12,0	22,3	1500
280	340	NNU40/900KM**		933	963	-	1257	6,0	6,0	12,0	22,3	1500
230	280	NNU41/900M**		947	1008	-	1394	10,0	5,0	12,0	22,3	3180
230	280	NNU41/900KM**		947	1008	-	1394	10,0	10,0	12,0	22,3	3180
270	320	NNU40/950M**	950	983	1033	-	1327	6,0	6,0	12,0	22,3	1900
270	320	NNU40/950KM**		983	1033	-	1327	6,0	6,0	12,0	22,3	1900
220	260	NNU41/950M**		997	1068	-	1474	10,0	5,0	12,0	22,3	3830
220	260	NNU41/950KM**		997	1068	-	1474	10,0	10,0	12,0	22,3	3830
280	340	NN49/1000M**	1000	1033	-	1249	1287	6,0	6,0	12,0	22,3	1200
280	340	NN49/1000KM**		1033	-	1249	1287	6,0	6,0	12,0	22,3	1200
250	300	NNU40/1000M**		1033	1084	-	1387	6,0	6,0	12,0	22,3	2000
250	300	NNU40/1000KM**		1033	1084	-	1387	6,0	6,0	12,0	22,3	2000
200	240	NNU41/1000M**		1047	1128	-	1474	10,0	5,0	12,0	22,3	4270
200	240	NNU41/1000KM**		1047	1128	-	1474	10,0	10,0	12,0	22,3	4270

SINGLE ROW FULL COMPLEMENT CYLINDRICAL ROLLER BEARINGS

Design

Single row full complement cylindrical roller bearings suit locations with high radial load and lower revolution frequencies, comparing to roller bearings with cage. Full complement cylindrical roller bearings have the highest possible number of rollers, and are cageless; they are manufactured in two versions.

NSF design

Inner bearing ring has guide flanges on both sides; the outer ring has one guide flange (fig. 12.4.14). NSF design bearing is axially guiding in one direction; in one direction the bearing captures axial load whilst in other direction it allows axial displacement of shaft against the body. Outer ring is on the side without guide flange provided with snap ring that ensures components in assembled state. The NSF design complies with SKF bearings in NCF version, and with FAG bearings in SL1818, SL1829, SL1830 and SL1822 version.

NJB design

Outer bearing ring has guide flanges on both sides; the inner ring has one guide flange (fig. 12.4.15). NJB design bearing is axially guiding in one direction; in one direction the bearing captures axial load whilst in other direction it allows axial displacement of shaft against body. NJB bearing is a separable type bearing; when inner ring is dismantled, rollers are held together by outer ring which is given by optimum adjustment of the outer ring raceway diameter, diameter and number of rollers. NJB bearing is in the heavy dimension series 23. The NJB design complies with SKF bearings in NJG design, and with FAG bearings in SL1923 design.

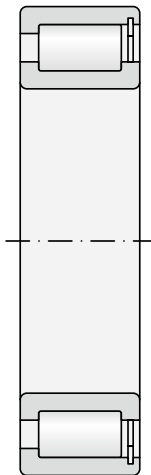

Fig. 12.4.14

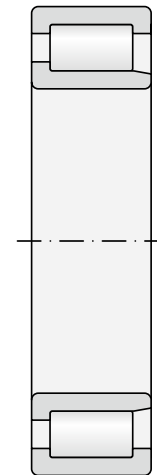

Fig. 12.4.15

General information

Main dimensions

The main dimensions of single row full complement cylindrical roller bearings stated in the dimension tables comply with international dimensional plan ISO 15.

Tolerances

Single row full complement cylindrical roller bearings are usually made in normal accuracy level P0 which is not presented. The limit values of bearing dimension and run accuracy deviations comply with the standard ISO 492.



Radial clearance

Single row full complement cylindrical roller are usually made with normal radial clearance that is not designated on the bearing. Bearings are made also with increased radial clearance C3; the availability must be consulted with the supplier. Values of radial clearances comply with the standard ISO 5753 and apply for bearings in non-assembled state (see Tab. 7.19).

Misalignment

The same conditions as for usual single row roller bearings with cage apply to misalignment of single row full complement cylindrical roller bearings. (See the chapter Single row roller bearings.)

Service temperatures

Rings of single row full complement cylindrical roller bearings are usually made with dimension stabilisation "S0"; service temperature of these bearings is therefore within 150 °C. Upon request, roller bearings with "S1" dimension stabilisation for operation at temperatures up to 200 °C can be supplied.

Minimum load

Minimum radial load recommended for single row full complement cylindrical roller bearings is such that equals to 4% of the basic dynamic load bearing capacity of the bearing.

Axial dynamic load rating

Single row full complement cylindrical roller bearings can besides radial load transfer also single direction axial load. In usual service conditions when the temperature difference between the bearing and ambient area does not exceed 60 °C at specific heat passage of 0.5 mWmm⁻²°C⁻¹, at minimum value of viscosity rate 2, the maximum admissible axial load can be calculated with sufficient accuracy from the below equation:

for lubrication with oil

$$F_{a \max} = \frac{C_{or} \cdot 10^4}{n (d + D)} - 0.3 F_r \quad [\text{kN}]$$

for lubrication with grease

$$F_{a \max} = \frac{0.5 C_{or} \cdot 10^4}{n (d + D)} - 0.15 F_r \quad [\text{kN}]$$

$F_{a \max}$ maximum admissible axial load [kN]

C_{or} basic radial static load rating [kN]

F_r radial load of bearings [kN]

n rotational frequency [min⁻¹]

d bearing bore diameter [mm]

D outer diameter of bearing [mm]

The $F_{a \max}$ values calculated according to the above stated equations apply on condition of acting of constant axial force. In case of interrupted load or impact load the admissible axial load can grow by two or three times towards the calculated value. At acting axial load roller bearings operate reliably only if the bearings are loaded radially at the same time. The relation $F_a/F_r \leq 0.5$ has to be maintained.

Equivalent dynamic load of bearing

Axially guiding bearings are capable of transferring both radial and axial load; the following applies to these bearings:

$$P = F_r \quad \text{for } F_a/F_r \leq e$$

$$P = 0.92 F_r + Y F_a \quad \text{for } F_a/F_r > e$$

where the arithmetic coefficient e = 0.2 for bearings of series 18

. = 0.3 for bearings of other series 22, 23, 28, 29 and 30

and axial load coefficient Y = 0.6 for bearings of series 18

. = 0.4 for bearings of other series 22, 23, 28, 29 and 30

Equivalent static load of bearing

$$P_0 = F_r$$

Additional designations

- CV modified internal designation, full complement
- V full complement (without cage)
- VH full complement, rolling elements form non-separable unit with at least one ring

DOUBLE ROW FULL COMPLEMENT CYLINDRICAL ROLLER BEARINGS



Design

Double row full complement cylindrical roller bearings transfer big radial loads but at lower rpm than usual bearings with cage. These bearings have as many rolling elements as possible, and are in cageless version. ZKL manufacture these bearings in three versions that are non-separable and uncovered.

NNSL design

Inner bearing ring has three guide flanges; outer bearing ring does not have any flange; outer ring is provided with snap ring located between the rollers which secures components in assembled state (fig. 12.4.16). NNSL bearing version is axially free; it allows axial displacement of shaft against body. The NNSL design complies with SKF bearings in NNCL version, and with FAG bearings in SLO248 and SLO249 version.

NNSF design

Inner bearing ring has three guide flanges; outer bearing ring has one guide flange and snap ring on the other side which secures components in assembled state (fig. 12.4.17). NNSF bearing is axially guiding in one direction; it can capture axial load on the guide flange side. The NNSF design complies with SKF bearings in NNCF version, and with FAG bearings in SL1850 version.

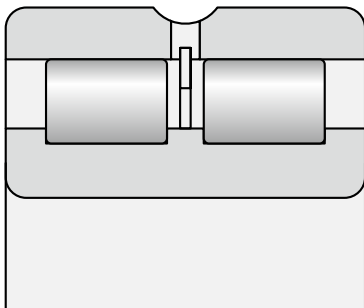

Fig. 12.4.16

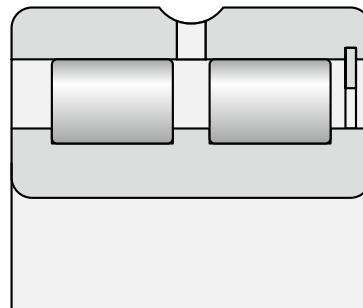

Fig. 12.4.17

NNS design

Inner bearing ring has three guide flanges; outer bearing ring is split and has two guide flanges; outer ring is connected with snap rings that should not be axially stressed. NNS bearing version is axially guiding in both directions. The NNS design complies with SKF bearings in NNC version, and with FAG bearings in SL0148 a SL0149 version.

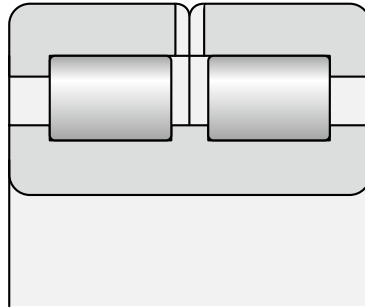

Fig. 12.4.18

General information

Main dimensions

Main dimensions of double row full complement cylindrical roller bearings stated in the dimensional tables comply with the international dimensional plan ISO 15.

Tolerances

Double row full complement cylindrical roller bearings are usually made in normal accuracy level P0 which is not presented. Bearings can be also made in increased accuracy class P6; the availability of these bearings must be consulted with the supplier. The limit values of bearing dimension and run accuracy deviations comply with the standard ISO 492.

Radial clearance

Single row full complement cylindrical roller bearings are usually made with normal radial clearance that is not designated on the bearing. Bearings are made also with increased radial clearance C3 and reduced radial clearance C2; the availability must be consulted with the supplier. Values of radial clearances comply with the standard ISO 5753 and apply for bearings in non-assembled state (see Tab. 7.19).

Axial clearance

NNC bearing version that is axially guided in both directions must have certain axial clearance that ranges within 0.1 to 0.2 mm for all bearing sizes.

Sliding axial movement

Double row full complement cylindrical roller bearings in NNSL and NNSF version are to certain extent capable of alignment of the shaft axial displacement against the body without reducing the service life of the bearing. The values of maximum axial slide "s" (fig. 12.4.19) are stated in the table section.

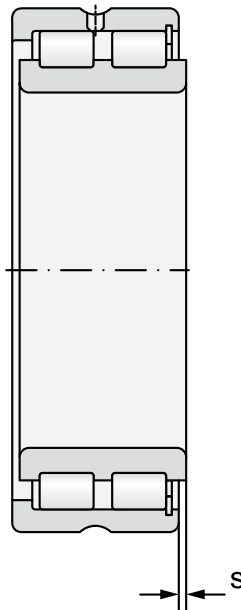

Fig. 12.4.19

Misalignment

Misalignment of inner ring in double row full complement cylindrical roller bearings against outer ring produces torque load in the bearing which leads to increased load and shortened service life of the bearing.

Running temperatures

Rings of double row full complement cylindrical roller bearings are usually made with dimension stabilisation "S0"; service temperature of these bearings is therefore within 150 °C.

Upon request, roller bearings with "S1" dimension stabilisation for operation at temperatures up to 200 °C can be supplied.

Lubrication groove and bores on outer ring

All sizes of double row full complement cylindrical roller bearings are manufactured with a slot and lubrication bores on outer ring (W33). This design allows supply of lubricant directly in the bearing between two rows of rollers which will ensure better lubrication of bearings and higher service reliability.

Minimum load

Minimum radial load recommended for double row full complement cylindrical roller bearings is such that equals to 4 % of the basic dynamic load bearing capacity of the bearing.

Axial dynamic load capacity

Double row full complement cylindrical roller bearings can besides radial load transfer also axial load in one direction. In usual service conditions when the temperature difference between the bearing and ambient area does not exceed 60 °C at specific heat passage of 0.5 mWmm⁻²°C⁻¹, at minimum value of viscosity rate 2, the maximum admissible axial load can be calculated with sufficient accuracy from the below equation:

for lubrication with oil

$$F_{a \max} = \frac{0.35 C_{or} \cdot 10^4}{n (d + D)} - 0.1 F_r \quad [\text{kN}]$$

for lubrication with grease

$$F_{a \max} = \frac{0.2 C_{or} \cdot 10^4}{n (d + D)} - 0.06 F_r \quad [\text{kN}]$$

$F_{a \max}$ maximum admissible axial load [kN]

C_{or} basic radial static load rating [kN]

F_r radial load of bearings [kN]

n rotational frequency [min⁻¹]

d bearing bore diameter [mm]

D outer diameter of bearing [mm]

The $F_{a \max}$ values calculated according to the above stated equations apply on condition of acting of constant axial force. In case of interrupted load or impact load the admissible axial load can grow by two or three times towards the calculated value.

At acting axial load cylindrical roller bearings operate reliably only if the bearings are loaded radially at the same time. The relation $F_a/F_r \leq 0.25$ has to be maintained.

Equivalent dynamic load of bearing

Axially free NNSL type bearings are capable of transferring radial load only; the following applies to these bearings:

$$P = F_r$$

Axially guiding bearings in NNCF and NNC version are capable of transferring both radial and axial load; the following applies to these bearings:

$$P = F_r \quad \text{for } F_a/F_r \leq e$$

$$P = 0.92 F_r + Y F_a \quad \text{for } F_a/F_r > e$$

where the arithmetic coefficient $e = 0.15$ for double row full complement bearing

and axial load coefficient $Y = 0.4$ for double row full complement bearing

Equivalent static load of bearing

$$P_0 = F_r$$

Additional designations

CV modified internal design, full complement

V full complement (without cage)



Single row full complement cylindrical roller bearings d = 20 to 1000 mm

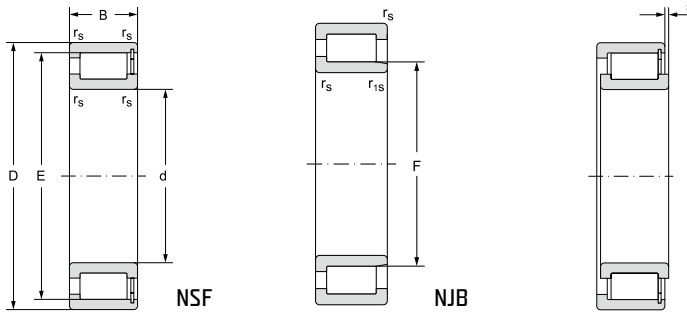

12.4.3

Main dimensions								Bearing designation	Basic load rating	
d	D	B	r _s	r _{1s}	F	E	s ¹⁾		C _r	C _{or}
			min	min				kN		
20	42	16,00	0,6	0,6		36,80	1,5	NSF3004CV	26,0	28,0
25	47	16,00	0,6	0,6			1,5	NSF3005CV	30,0	34,0
	62	24,00	1,1		31,74		1,7	NJB2305VH	64,0	65,0
30	55	19,00	1,0	1,0		49,60	2,0	NSF3006CV	37,0	41,0
	72	27,00	1,1		38,36		1,8	NJB2306VH	80,0	82,0
35	62	20,00	1,0	1,0		55,50	2,0	NSF3007CV	46,0	53,0
	80	31,00	1,5		44,75		2,0	NJB2307VH	103,0	108,0
40	68	21,00	1,0	1,0		61,70	2,0	NSF3008CV	53,0	65,0
	90	33,00	1,5		51,15		2,4	NJB2308VH	138,0	149,0
45	75	23,00	1,0	1,0		66,90	2,0	NSF3009CV	55,0	71,0
	100	36,00	1,5		56,14		2,4	NJB2309VH	167,0	188,0
50	80	23,00	1,0	1,0		72,30	2,0	NSF3010CV	70,0	93,0
55	90	26,00	1,1	1,1		83,50	2,0	NSF3011CV	100,0	136,0
	120	43,00	2,0		67,14		2,6	NJB2311VH	225,0	250,0
60	85	16,00	1,0	1,0		78,65	1,0	NSF2912CV	51,0	75,0
	95	26,00	1,1	1,1		86,70	1,6	NSF3012CV	101,0	137,0
65	90	16,00	1,0	1,0		85,35	1,0	NSF2913CV	54,0	82,0
	100	26,00	1,1	1,1		93,10	2,0	NSF3013CV	106,0	155,0
	140	48,00	2,1		80,71		3,0	NJB2313VH	291,0	345,0
70	100	19,00	1,0	1,0		92,50	1,0	NSF2914CV	72,0	108,0
	110	30,00	1,1	1,1		100,30	3,0	NSF3014CV	119,0	164,0
	150	51,00	2,1		84,22		3,0	NJB2314VH	324,0	389,0
75	105	19,00	1,0	1,0		97,60	1,0	NSF2915CV	73,0	112,0
	115	30,00	1,1	1,1		107,90	3,0	NSF3015CV	124,0	181,0
	160	55,00	2,1		91,24		3,0	NJB2315VH	379,0	463,0
80	110	19,00	1,0	1,0		102,70	1,0	NSF2916CV	76,0	123,0
	125	34,00	1,1	1,1		117,00	4,0	NSF3016CV	151,0	219,0
	170	58,00	2,1		98,26		4,0	NJB2316VH	437,0	552,0

d = 20 to 80 mm

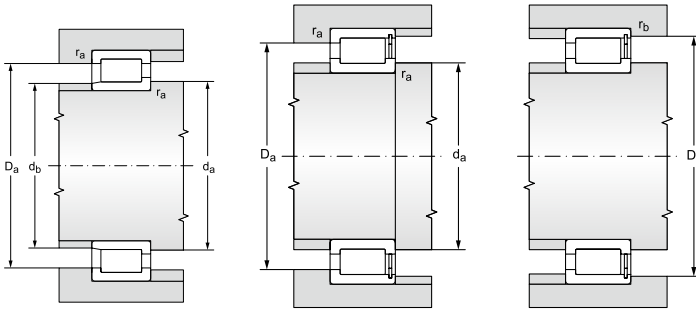

¹⁾ Admissible axial movement
²⁾ Recommended diameter of fitting for axially loaded bearings



Fatigue load limit	Limiting speed for lubrication with		Abutment and fillet dimensions								Weight
	grease	oil	d	d _a	d _{as} ²⁾	d _b	D _a	D _b	r _a	r _b	
P _u				min		max	max	max	max	max	~
kN	min ⁻¹		mm								kg
3,41	6900	8200	20	24	26,9	-	38	40	0,6	0,6	0,11
4,15	5700	6800	25	29	32,3	-	43	45	0,6	0,6	0,12
7,93	3600	4300		32	33,9	30,0	55	-	1,0		0,38
5,00	4800	5700	30	35	37,8	-	50	52	1,0	1,0	0,20
10,00	3315	3900		37	40,8	36,0	65	-	1,0		0,56
6,46	4300	5100	35	40	42,8	-	57	59	1,0	1,0	0,26
13,17	2800	3300		44	47,6	42,0	71	-	1,5		0,75
7,93	3900	4600	40	45	47,9	-	63	65	1,0	1,0	0,31
18,17	2400	2900		49	54,4	49,0	81	-	1,5		1,00
8,66	3400	4100	45	50	53,0	-	70	72	1,0	1,0	0,40
22,93	2200	2700		54	59,3	54,0	91	-	1,5		1,45
11,34	3200	3800	50	55	56,7	-	75	77	1,0	1,0	0,43
16,59	2700	3200	55	61	65,8	-	84	86	1,0	1,0	0,64
30,49	1780	2100		66	71,3	66,0	109	-	2,0		2,30
9,15	2900	3500	60	65	66,8	-	80	80	1,0	1,0	0,29
16,71	2800	3300		66	68,9	-	89	91	1,0	1,0	0,69
10,00	2600	3100	65	70	73,4	-	85	85	1,0	1,0	0,31
18,90	2400	2900		71	75,6	-	94	96	1,0	1,0	0,73
42,07	1500	1800		77	85,3	78,0	128	-	2,0		3,55
13,17	2400	2900	70	75	78,5	-	95	95	1,0	1,0	0,49
20,00	2200	2700		76	78,7	-	104	106	1,0	1,0	1,02
47,44	1400	1700		82	89,0	81,0	138	-	2,0		4,40
14,10	2200	2700	75	80	83,8	-	100	100	1,0	1,0	0,52
22,42	2100	2500		81	86,5	-	109	111	1,0	1,0	1,06
53,80	1200	1500		87	96,1	88,0	148	-	2,0		5,35
15,23	2100	2500	80	85	88,6	-	105	105	1,0	1,0	0,55
26,51	1900	2300		86	92,0	-	119	121	1,0	1,0	1,43
62,96	1100	1400		92	104,0	95,0	158	-	2,0		6,40

Single row full complement cylindrical roller bearings

d = 85 to 160 mm

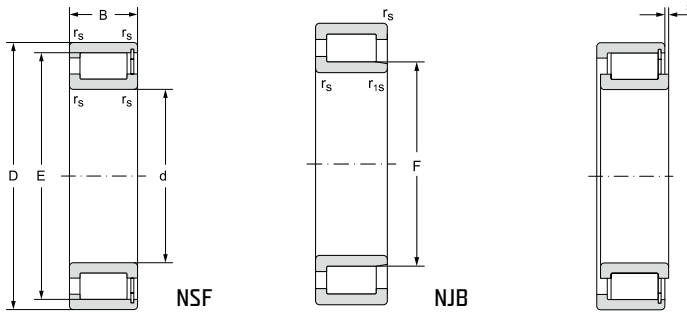

12.4.3

Main dimensions								Bearing designation	Basic load rating	
d	D	B	r _s	r _{1s}	F	E	s ¹⁾		C _r	C _{or}
			min	min					kN	
mm										
85	120	22,00	1,1	1,1		109,70	1,0	NSF2917CV	94,0	156,0
	130	34,00	1,1	1,1		121,40	4,0	NSF3017CV	160,0	225,0
	180	60,00	3,0		107		4,0	NJB2317VH	455,0	605,0
90	125	22,00	1,1	1,1		115,60	1,0	NSF2918CV	98,0	165,0
	140	37,00	1,5	1,5		130,10	4,0	NSF3018CV	185,0	260,0
	190	64,00	3,0		105,3		4,0	NJB2318VH	505,0	650,0
100	140	24,00	1,1	1,1		130,60	1,5	NSF2920CV	110,0	185,0
	150	37,00	1,5	1,5		139,70	4,0	NSF3020CV	195,0	295,0
	215	73,00	3,0		119,3		4,0	NJB2320VH	665,0	850,0
110	150	24,00	1,1	1,1		141,10	1,5	NSF2922CV	120,0	205,0
	170	45,00	2,0	2,0		156,10	5,5	NSF3022CV	260,0	375,0
	240	80,00	3,0		134,3		5,0	NJB2322VH	840,0	1030,0
120	165	27,00	1,1	1,1		154,30	1,5	NSF2924CV	160,0	275,0
	180	46,00	2,0	2,0		167,60	5,5	NSF3024CV	275,0	420,0
	215	58,00	2,1	2,1		192,32	4,0	NSF2224V	500,0	720,0
	260	86,00	3,0		147,4		5,0	NJB2324VH	925,0	1200,0
130	180	30,00	1,5	1,5		167,10	2,0	NSF2926CV	190,0	340,0
	200	52,00	2,0	1,0		183,00	5,5	NSF3026CV	395,0	600,0
	280	93,00	4,0		157,9		6,0	NJB2326VH	1040,0	1400,0
140	190	30,00	1,5	1,5		180,00	2,0	NSF2928CV	205,0	375,0
	210	53,00	2,0	1,0		197,00	5,5	NSF3028CV	420,0	660,0
	250	68,00	3,0	3,0		221,90	5,0	NSF2228V	680,0	1000,0
	300	102,00	4,0		168,5		6,5	NJB2328VH	1150,0	1560,0
150	210	36,00	2,0	2,0		196,40	2,5	NSF2930CV	275,0	475,0
	225	56,00	2,1	1,1		206,00	7,0	NSF3030CV	440,0	695,0
	270	73,00	3,0	3,0		236,70	6,0	NSF2230V	770,0	1130,0
	320	108,00	4,0		182,5		6,5	NJB2330VH	1390,0	1870,0
160	220	36,00	2,0	2,0		207,20	2,5	NSF2932CV	290,0	510,0
	240	60,00	2,1	1,1		224,00	7,0	NSF3032CV	490,0	780,0
	290	80,00	3,0	3,0		266,40	6,0	NSF2232V	970,0	1470,0

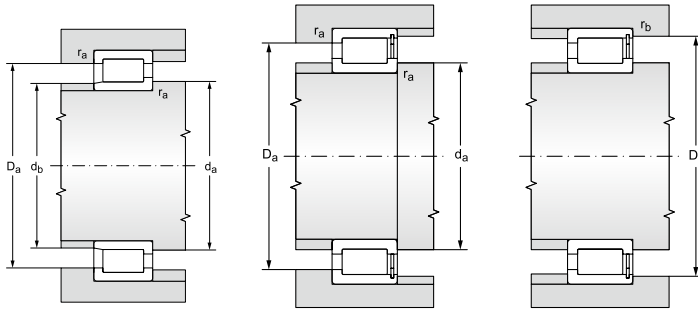

1) Admissible axial movement
 2) Recommended diameter of fitting for axially loaded bearings



Fatigue load limit	Limiting speed for lubrication with		Abutment and fillet dimensions								Weight	
	grease	oil	d	d _a	d _{as} ²⁾	d _b	D _a	D _b	r _a	r _b		
P _u				min		max	max	max	max	max	~	
kN	min ⁻¹		mm									kg
18,88	2100	2500	85	91	93,9	-	114	114	1,0	1,0	0,81	
26,85	1900	2300		91	96,2	-	124	126	1,0	1,0	1,51	
67,81	1100	1300		99	113,0	104,0	166	-	2,5		7,40	
19,69	1900	2300	90	96	99,8	-	119	119	1,0	1,0	0,84	
30,41	1700	2100		97	103,0	-	133	135	1,5	1,5	1,97	
71,66	1100	1300		104	111,0	105,0	176	-	2,5		8,75	
21,36	1700	2100	100	106	111,0	-	134	134	1,0	1,0	1,14	
33,65	1600	1900		107	112,0	-	143	145	1,5	1,5	2,15	
90,45	900	1100		114	126,0	119,0	201	-	2,5		13,0	
23,11	1500	1800	110	116	122,0	-	144	144	1,0	1,0	1,23	
41,34	1400	1700		120	124,0	-	160	165	2,0	2,0	3,50	
106,20	850	1000		124	143,0	130,0	226	-	2,5		17,5	
30,16	1400	1700	120	126	133,0	-	159	159	1,0	1,0	1,73	
45,35	1300	1600		130	135,0	-	170	175	2,0	2,0	3,80	
75,22	1100	1300		131	145,0	-	204	204	2,0	2,0	9,05	
120,71	850	1000		134	156,0	142,0	246	-	2,5		22,5	
36,36	1200	1500	130	137	143,0	-	173	173	1,5	1,5	2,33	
62,96	1100	1400		140	148,0	-	190	195	2,0	1,0	5,80	
137,65	800	950		147	166,0	153,0	263	-	3,0		28,0	
39,35	1100	1400	140	147	155,0	-	183	183	1,5	1,5	2,42	
68,05	1100	1300		150	159,0	-	200	205	2,0	1,0	6,10	
99,81	900	1100		143	167,0	-	127	127	2,5	2,5	14,5	
150,17	720	850		157	178,0	163,0	283	-	3,0		35,5	
48,56	1100	1300	150	159	166,0	-	201	201	2,0	2,0	3,77	
70,19	1000	1200		161	167,0	-	214	234	2,0	1,0	7,50	
110,31	850	1000		153	178,0	-	137	137	2,5	2,5	18,4	
176,48	680	800		167	192,0	178,0	303	-	3,0		42,5	
51,30	1000	1200	160	169	177,0	-	211	211	2,0	2,0	4,00	
77,26	900	1100		171	180,0	-	229	304	2,0	1,0	9,10	
140,56	800	950		163	201,0	-	147	147,0	2,5	2,5	23,0	

Single row full complement cylindrical roller bearings

d = 170 to 280 mm

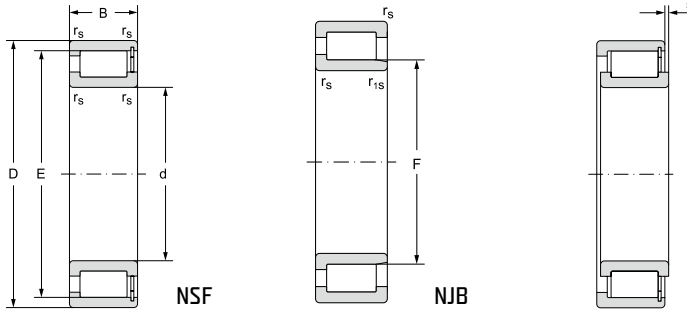

12.4.3

Main dimensions								Bearing designation	Basic load rating	
d	D	B	r _s	r _{1s}	F	E	s ¹⁾		C _r	C _{or}
			min	min				kN		
170	230	36,00	2,0	2,0		218,00	2,5	NSF2934CV	300,0	545,0
	260	67,00	2,1	1,1		242,00	7,0	NSF3034CV	640,0	1030,0
	310	86,00	4,0	4,0		281,10	7,0	NSF2234V	1050,0	1670,0
	360	120,00	4,0		203,55		7,0	NJB2334VH	1690,0	2410,0
180	250	42,00	2,0	2,0		232,00	2,5	NSF2936CV	375,0	680,0
	280	74,00	2,1	2,1		260,00	7,0	NSF3036CV	740,0	1210,0
	380	126,00	4,0		221,7		8,0	NJB2336VH	1800,0	2620,0
190	260	42,00	2,0	2,0		244,00	2,5	NSF2938CV	415,0	765,0
	290	75,00	2,1	2,1		269,00	9,0	NSF3038CV	765,0	1275,0
	340	92,00	4,0	4,0		311,00	7,0	NSF2238V	1200,0	1880,0
	400	132,00	5,0		224,5		8,0	NJB2338VH	2090,0	2970,0
200	250	24,00	1,5	1,1		237,50	1,8	NSF1840V	170,0	330,0
	280	48,00	2,1	2,1		262,00	3,0	NSF2940CV	515,0	950,0
	310	82,00	2,1	2,1		287,00	9,0	NSF3040CV	880,0	1500,0
	420	138,00	5,0		238,6		9,0	NJB2340VH	2200,0	3150,0
220	270	24,00	1,5	1,1		258,00	1,8	NSF1844V	180,0	360,0
	300	48,00	2,1	2,1		283,00	3,0	NSF2944CV	525,0	1030,0
	340	90,00	3,0	3,0		312,00	9,0	NSF3044CV	1030,0	1770,0
	400	108,00	4,0	4,0		366,00	8,0	NSF2244V	1800,0	2700,0
	460	145,00	5,0		266,7		10,0	NJB2344VH	2450,0	3510,0
240	300	28,00	2,0	1,1		287,00	1,8	NSF1848V	250,0	510,0
	320	48,00	2,1	2,1		303,00	3,0	NSF2948CV	545,0	1110,0
	360	92,00	3,0	3,0		335,00	11,0	NSF3048CV	1080,0	1940,0
	500	155,00	5,0		280,6		10,0	NJB2348VH	2710,0	3860,0
260	320	28,00	2,0	1,1		307,20	1,8	NSF1852V	260,0	550,0
	360	60,00	2,1	2,1		333,00	3,5	NSF2952CV	715,0	1400,0
	400	104,00	4,0	4,0		376,00	11,0	NSF3052CV	1450,0	2520,0
	540	165,00	6,0		615,6		11,0	NJB2352VH	3300,0	4770,0
280	350	33,00	2,0	1,1		334,00	2,5	NSF1856V	330,0	690,0
	380	60,00	2,1	2,1		359,10	3,5	NSF2956CV	840,0	1710,0
	420	106,00	4,0	4,0		391,00	11,0	NSF3056CV	1690,0	2630,0

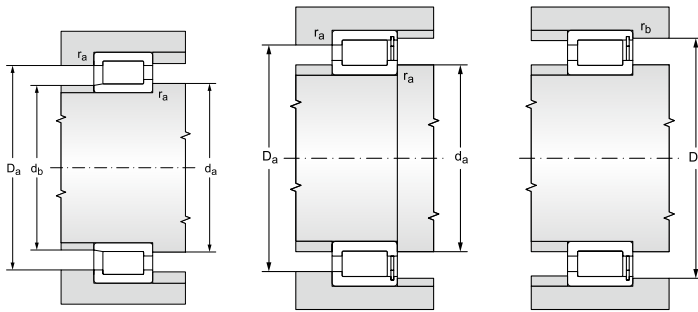

1) Admissible axial movement
2) Recommended diameter of fitting for axially loaded bearings



Fatigue load limit	Limiting speed for lubrication with		Abutment and fillet dimensions								Weight	
	grease	oil	d	d _a	d _{as} ²⁾	d _b	D _a	D _b	r _a	r _b		
P _u				min		max	max	max	max	max	~	
kN	min ⁻¹		mm									kg
53,99	900	1100	170	179	188,0	-	221	221,0	2,0	2,0	4,30	
99,84	850	1000		181	192,0	-	249	274,0	2,0	1,0	12,5	
156,62	760	900		185	212,0	-	295	295,0	3,0	3,0	28,7	
219,40	590	700		187	214,0	200,0	343	-	3,0		59,5	
65,91	850	1000	180	189	199,0	-	241	241,0	2,0	2,0	6,20	
114,94	850	1000		191	206,0	-	269	269,0	2,0	2,0	16,5	
234,61	570	670		197	232,0	216,0	363	-	3,0		69,5	
73,15	850	1000	190	199	208,0	-	251	251,0	2,0	2,0	6,50	
119,57	850	1000		201	216,0	-	279	279,0	2,0	2,0	17,0	
171,15	680	800		205	235,0	-	325	325,0	3,0	3,0	35,7	
261,82	530	630		210	237,0	222,0	380	-	4,0		80,0	
31,55	850	1000	200	207	215,0	-	243	245,0	1,5	1,0	2,60	
89,09	830	980		211	222,0	-	269	269,0	2,0	2,0	9,10	
138,14	800	950		211	230,0	-	299	299,0	2,0	2,0	22,5	
273,58	630	750		220	252,0	232,0	400	-	4,0		92,0	
33,55	800	950	220	227	235,0	-	263	265,0	1,5	1,0	2,85	
94,30	800	950		231	242,0	-	289	289,0	2,0	2,0	9,90	
158,49	720	850		233	248,0	-	327	327,0	2,5	2,5	29,5	
234,50	590	700		235	260,0	-	385	385,0	3,0	3,0	58,0	
296,52	570	670		240	281,0	260,0	440	-	4,0		111	
46,17	760	900	240	249	259,0	-	291	295,0	2,0	1,0	4,40	
99,39	720	850		251	263,0	-	309	309,0	2,0	2,0	10,6	
170,16	680	800		253	271,0	-	347	347,0	2,5	2,5	32,0	
317,92	530	630		260	295,0	282,0	480	-	4,0		147	
48,73	680	800	260	270	279,0	-	310	315,0	2,0	1,0	4,75	
121,59	630	750		271	286,0	-	349	349,0	2,0	2,0	18,5	
214,80	590	700		275	295,0	-	385	385,0	3,0	3,0	46,5	
383,78	360	430		286	332,0	309,0	514	-	5,0		177	
59,64	630	750	280	289	303,0	-	341	344,0	2,0	1,0	7,10	
145,76	590	700		291	309,0	-	369	369,0	2,0	2,0	19,7	
220,25	570	670		295	310,0	-	405	405,0	3,0	3,0	50,0	

Single row full complement cylindrical roller bearings

d = 300 to 460 mm

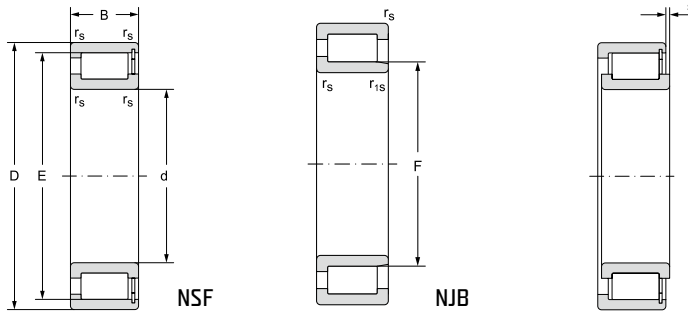

12.4.3

Main dimensions								Bearing designation	Basic load rating	
d	D	B	r _s	r _{1s}	F	E	s ¹⁾		dynamic C _r	static C _{or}
mm								kN		
300	380	38,00	2,1	1,5		363,00	3,0	NSF1860V	410,0	850,0
	420	72,00	3,0	3,0		390,50	5,0	NSF2960CV	1050,0	2180,0
	460	118,00	4,0	4,0		433,00	14,0	NSF3060CV	1810,0	3230,0
320	400	38,00	2,1	1,5		383,00	3,0	NSF1864V	430,0	900,0
	440	72,00	3,0	3,0		411,00	5,0	NSF2964CV	1070,0	2340,0
	480	121,00	4,0	4,0		449,00	14,0	NSF3064CV	1900,0	3440,0
340	420	38,00	2,1	1,5		403,00	3,0	NSF1868V	440,0	950,0
	460	72,00	3,0	3,0		431,00	5,0	NSF2968CV	1100,0	2490,0
	520	133,00	5,0	5,0		485,00	14,0	NSF3068CV	2300,0	4140,0
360	440	38,00	2,1	1,5		418,90	4,5	NSF1872V	400,0	900,0
	480	72,00	3,0	3,0		451,50	5,0	NSF2972CV	1150,0	2590,0
	540	134,00	5,0	5,0		503,00	14,0	NSF3072CV	2340,0	4290,0
380	480	46,00	2,1	1,5		458,00	3,5	NSF1876V	620,0	1290,0
	520	82,00	4,0	4,0		488,00	5,0	NSF2976CV	1460,0	3230,0
	560	135,00	5,0	5,0		521,00	14,0	NSF3076CV	2430,0	4540,0
400	500	46,00	2,1	1,5		475,00	3,5	NSF1880V**	620,0	1340,0
	540	82,00	4,0	4,0		511,00	5,0	NSF2980CV**	1550,0	3450,0
	600	148,00	5,0	5,0		558,00	14,0	NSF3080CV**	2850,0	5500,0
420	520	46,00	2,1	1,5		499,00	3,5	NSF1884V**	660,0	1430,0
	560	82,00	4,0	4,0		524,00	5,0	NSF2984CV**	1550,0	3600,0
	620	150,00	5,0	5,0		577,00	15,0	NSF3084CV**	2930,0	5700,0
440	540	46,00	2,1	1,5		516,00	3,5	NSF1888V**	670,0	1460,0
	540	60,00	2,1	1,5		516,00	3,5	NSF2888V**	1050,0	2700,0
	600	95,00	4,0	4,0		565,50	6,0	NSF2988V**	2010,0	4400,0
	650	157,00	6,0	6,0		611,00	16,0	NSF3088CV**	3430,0	6550,0
460	580	56,00	3,0	3,0		553,00	5,0	NSF1892V**	910,0	1960,0
	580	72,00	3,0	3,0		553,00	5,0	NSF2892V**	1300,0	3050,0
	620	95,00	4,0	4,0		579,00	6,0	NSF2992V**	2050,0	4500,0
	680	163,00	6,0	6,0		635,00	16,0	NSF3092CV**	3570,0	6950,0

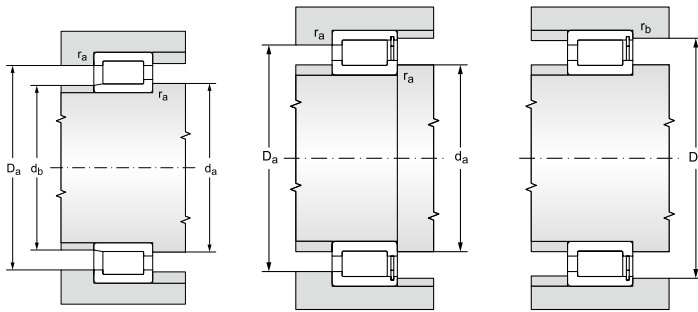

1) Admissible axial movement
 2) Recommended diameter of fitting for axially loaded bearings
 Bearings in the new standard
 NEW FORCE



Fatigue load limit	Limiting speed for lubrication with		Abutment and fillet dimensions								Weight	
	grease	oil	d	d _a	d _{as} ²⁾	d _b	D _a	D _b	r _a	r _b		
P _u				min		max	max	max	max	max	~	
kN	min ⁻¹		mm									kg
71,81	570	670	300	311	326,0	-	369	373,0	2,0	1,5	10,00	
181,03	570	670		313	334,0	-	407	407,0	2,5	2,5	31,2	
263,91	510	600		315	344,0	-	445	445,0	3,0	3,0	69,0	
74,74	530	630	320	331	346,0	-	389	393,0	2,0	1,5	10,5	
191,19	510	600		333	353,0	-	427	427,0	2,5	2,5	32,9	
276,77	470	560		335	359,0	-	465	465,0	3,0	3,0	74,5	
77,62	510	600	340	351	366,0	-	409	413,0	2,0	1,5	11,0	
200,34	470	560		353	373,0	-	447	447,0	2,5	2,5	35,0	
325,95	450	530		358	384,0	-	502	502,0	4,0	4,0	100,0	
72,41	470	560	360	371	384,0	-	429	433,0	2,0	1,5	11,5	
205,36	450	530		373	396,0	-	467	467,0	2,5	2,5	36,5	
333,18	420	500		378	402,0	-	522	522,0	4,0	4,0	105	
101,56	450	530	380	391	411,0	-	469	473,0	2,0	1,5	19,5	
250,86	420	500		395	420,0	-	505	505,0	3,0	3,0	52,5	
348,03	400	480		398	420,0	-	542	542,0	4,0	4,0	110	
104,07	420	500	400	411	428,0	-	489	493,0	2,0	1,5	20,5	
264,47	400	480		415	442,0	-	525	525,0	3,0	3,0	54,5	
413,86	380	450		418	449,0	-	582	582,0	4,0	4,0	145	
109,62	400	480	420	431	452,0	-	509	513,0	2,0	1,5	21,0	
272,54	380	450		435	455,0	-	545	545,0	3,0	3,0	57,0	
423,90	360	430		438	469,0	-	602	602,0	4,0	4,0	150	
110,53	380	450	440	451	469,0	-	529	533,0	2,0	1,5	22,0	
204,40	380	450		451	469,0	-	529	533,0	2,0	1,5	29,0	
327,22	360	430		455	492,0	-	585	585,0	3,0	3,0	80,5	
480,30	340	400		463	488,0	-	627	627,0	5,0	5,0	175	
145,76	360	430	460	473	495,0	-	567	567,0	2,5	2,5	34,0	
226,82	360	430		473	495,0	-	567	567,0	2,5	2,5	44,0	
330,89	340	400		475	506,0	-	605	605,0	3,0	3,0	83,5	
502,82	320	380		483	511,0	-	657	657,0	5,0	5,0	195	

Single row full complement cylindrical roller bearings

d = 480 to 750 mm

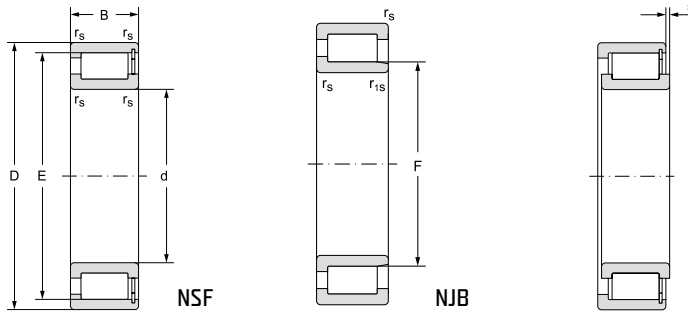

12.4.3

Main dimensions								Bearing designation	Basic load rating	
d	D	B	r _s	r _{1s}	F	E	s ¹⁾		C _r	C _{or}
mm								kN		
								dynamic	static	
								C _r	C _{or}	
480	600	56,00	3,0	3,0		573,50	5,0	NSF1896V**	930,0	2040,0
	600	72,00	3,0	3,0		573,50	5,0	NSF2896V**	1320,0	3150,0
	650	100,00	5,0	5,0		600,00	7,0	NSF2996V**	2280,0	4900,0
	700	165,00	6,0	6,0		654,00	16,0	NSF3096CV**	3600,0	7200,0
500	620	56,00	3,0	3,0		594,00	5,0	NSF18/500V**	950,0	2120,0
	620	72,00	3,0	3,0		594,00	2,4	NSF28/500V**	1340,0	3350,0
	670	100,00	5,0	5,0		630,90	7,0	NSF29/500V**	2300,0	5000,0
	720	167,00	6,0	6,0		676,00	16,0	NSF30/500CV**	3700,0	7500,0
530	650	56,00	3,0	3,0		624,50	5,0	NSF18/530V**	990,0	2230,0
	650	72,00	3,0	3,0		624,50	5,0	NSF28/530V**	1400,0	3450,0
	710	106,00	5,0	5,0		676,00	7,0	NSF29/530V**	2600,0	6100,0
	780	185,00	6,0	6,0		732,30	16,0	NSF30/530V**	5200,0	10600,0
560	680	56,00	3,0	3,0		655,00	5,0	NSF18/560V**	1020,0	2350,0
	680	72,00	3,0	3,0		655,00	4,3	NSF28/560V**	1400,0	3650,0
	750	112,00	5,0	5,0		718,00	7,0	NSF29/560V**	3050,0	6700,0
	820	195,00	6,0	6,0		770,00	16,0	NSF30/560V**	5800,0	11800,0
600	730	60,00	3,0	3,0		696,00	7,0	NSF18/600V**	1050,0	2550,0
	730	78,00	3,0	3,0		696,00	6,0	NSF28/600V**	1550,0	4300,0
	800	118,00	5,0	5,0		754,00	7,0	NSF29/600V**	3150,0	7100,0
630	780	69,00	4,0	4,0		739,00	8,0	NSF18/630V**	1250,0	2900,0
	780	88,00	4,0	4,0		739,00	8,0	NSF28/630V**	1850,0	5000,0
	850	128,00	6,0	6,0		807,00	8,0	NSF29/630V**	3750,0	8650,0
670	820	69,00	4,0	4,0		783,00	8,0	NSF18/670V**	1300,0	3150,0
	820	88,00	4,0	4,0		783,00	8,0	NSF28/670V**	1950,0	5300,0
	900	136,00	6,0	6,0		846,00	10,0	NSF29/670V**	3900,0	9000,0
710	870	74,00	4,0	4,0		831,00	8,0	NSF18/710V**	1550,0	3750,0
	870	95,00	4,0	4,0		831,00	8,0	NSF28/710V**	2330,0	6300,0
	950	140,00	6,0	6,0		896,00	10,0	NSF29/710V**	4300,0	10000,0
750	920	78,00	5,0	5,0		882,00	8,0	NSF18/750V**	1850,0	4500,0
	920	100,00	5,0	5,0		878,00	8,0	NSF28/750V**	2650,0	6950,0
	1000	145,00	6,0	6,0		937,00	11,0	NSF29/750V**	4450,0	10600,0

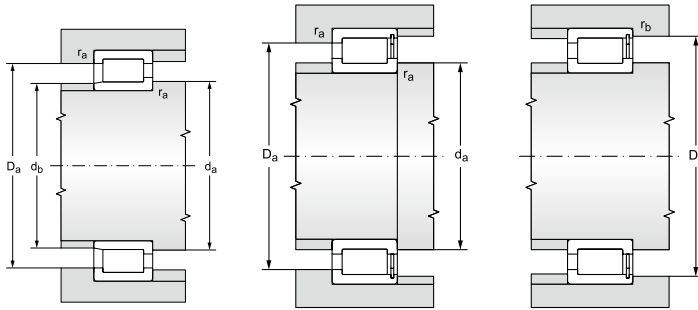

1) Admissible axial movement
 2) Recommended diameter of fitting for axially loaded bearings
 Bearings in the new standard
 NEW FORCE



Fatigue load limit	Limiting speed for lubrication with		Abutment and fillet dimensions								Weight	
	grease	oil	d	d _a	d _{as} ²⁾	d _b	D _a	D _b	r _a	r _b		
P _u				min		max	max	max	max	max	~	
kN	min ⁻¹		mm									kg
150,00	340	400	480	493	516,0	-	587	587,0	2,5	2,5	35,5	
231,62	340	400		493	516,0	-	587	587,0	2,5	2,5	46,0	
355,44	320	380		498	527,0	-	632	632,0	4,0	4,0	98,0	
515,54	300	360		503	532,0	-	677	677,0	5,0	5,0	205	
154,19	320	380	500	513	536,0	-	607	607,0	2,5	2,5	36,5	
243,65	320	380		513	536,0	-	607	607,0	2,5	2,5	48,0	
358,93	320	380		518	544,0	-	652	652,0	4,0	4,0	100,0	
531,68	300	360		523	553,0	-	697	697,0	5,0	5,0	215	
159,67	300	360	530	543	567,0	-	637	637,0	2,5	2,5	38,5	
247,03	300	360		543	566,0	-	637	637,0	2,5	2,5	49,5	
430,33	290	340		548	589,0	-	692	692,0	4,0	4,0	120	
735,56	270	320		553	595,0	-	757	757,0	5,0	5,0	300	
165,78	290	340	560	573	597,0	-	667	667,0	2,5	2,5	40,5	
257,49	290	340		573	599,0	-	667	667,0	2,5	2,5	54,0	
464,93	270	320		578	617,0	-	732	732,0	4,0	4,0	140	
806,15	250	300		583	626,0	-	797	797,0	5,0	5,0	345	
176,15	340	400	600	613	638,0	-	717	717,0	2,5	2,5	51,5	
297,04	340	400		613	638,0	-	717	717,0	2,5	2,5	67,5	
482,96	320	380		618	652,0	-	782	782,0	4,0	4,0	170	
196,85	250	300	630	645	674,0	-	765	765,0	3,0	3,0	72,5	
339,39	250	300		645	674,0	-	765	765,0	3,0	3,0	92,5	
578,67	240	280		653	698,0	-	827	827,0	5,0	5,0	205	
210,31	240	280	670	685	718,0	-	805	805,0	3,0	3,0	76,5	
353,85	240	280		685	718,0	-	805	805,0	3,0	3,0	97,5	
591,52	220	260		693	737,0	-	877	877,0	5,0	5,0	245	
246,00	220	260	710	725	759,0	-	855	855,0	3,0	3,0	92,5	
413,27	220	260		725	759,0	-	855	855,0	3,0	3,0	115	
646,34	200	240		733	761,0	-	927	927,0	5,0	5,0	275	
290,33	200	240	750	768	802,0	-	902	902,0	4,0	4,0	110	
448,40	200	240		768	799,0	-	902	902,0	4,0	4,0	140	
674,36	185	220		773	820,0	-	957	957,0	5,0	5,0	315	

Single row full complement cylindrical roller bearings

d = 800 to 1000 mm

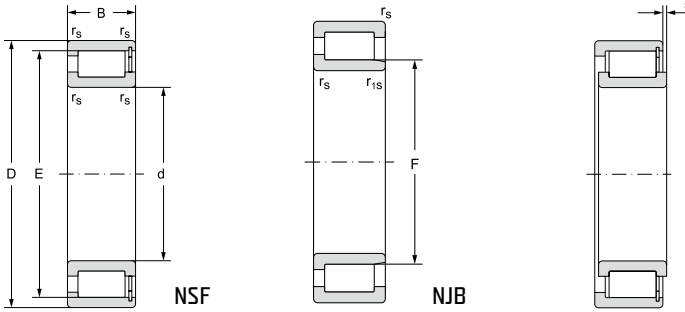

12.4.3

Main dimensions								Bearing designation	Basic load rating	
d	D	B	r _s	r _{1s}	F	E	s ¹⁾		dynamic C _r	static C _{or}
mm								kN		
			min	min						
800	980	82,00	5,0	5,0		936,00	9,0	NSF18/800V**	1950,0	4800,0
	980	106,00	5,0	5,0		936,00	10,0	NSF28/800V**	2750,0	7500,0
	1060	150,00	6,0	6,0		1002,00	11,0	NSF29/800V**	4950,0	12200,0
850	1030	82,00	5,0	5,0		985,00	9,0	NSF18/850V**	2000,0	5100,0
	1030	106,00	5,0	5,0		986,00	10,0	NSF28/850V**	2850,0	8000,0
	1120	155,00	6,0	6,0		1061,00	13,0	NSF29/850V**	5200,0	12700,0
900	1090	85,00	5,0	5,0		1044,00	9,0	NSF18/900V**	2350,0	6000,0
	1090	112,00	5,0	5,0		1044,00	10,0	NSF28/900V**	3200,0	9150,0
	1180	165,00	6,0	6,0		1120,00	13,0	NSF29/900V**	5900,0	14600,0
950	1150	90,00	5,0	5,0		1103,00	10,0	NSF18/950V**	2400,0	6300,0
	1150	118,00	5,0	5,0		1103,00	12,0	NSF28/950V**	3400,0	9800,0
	1250	175,00	7,5	7,5		1179,00	14,0	NSF29/950V**	6600,0	16300,0
1000	1220	100,00	6,0	6,0		1165,00	12,0	NSF18/1000V**	2900,0	7500,0
	1220	128,00	6,0	6,0		1165,00	12,0	NSF28/1000V**	4100,0	11600,0
	1320	185,00	7,5	7,5		1252,00	14,0	NSF29/1000V**	7450,0	18600,0

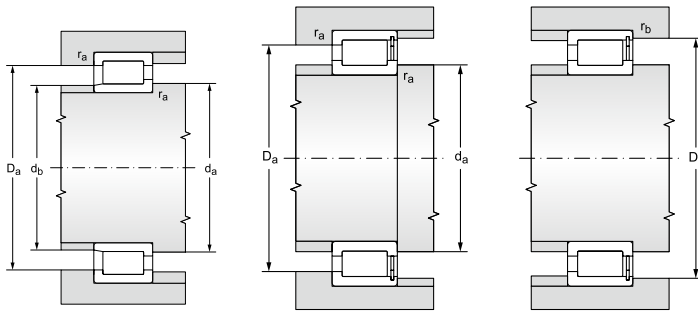

1) Admissible axial movement
 2) Recommended diameter of fitting for axially loaded bearings
 Bearings in the new standard
 NEW FORCE



Fatigue load limit	Limiting speed for lubrication with		Abutment and fillet dimensions								Weight	
	grease	oil	d	d _a	d _{as} ²⁾	d _b	D _a	D _b	r _a	r _b		
P _u				min		max	max	max	max	max	~	
kN	min ⁻¹		mm									kg
303,82	185	220	800	818	855,0	-	962	962,0	4,0	4,0	130	
474,71	185	220		818	855,0	-	962	962,0	4,0	4,0	165	
762,08	170	200		823	860,0	-	977	977,0	5,0	5,0	360	
317,55	170	200	850	868	902,0	-	1012	1012,0	4,0	4,0	135	
498,12	170	200		868	903,0	-	1012	1012,0	4,0	4,0	175	
779,76	160	190		873	914,0	-	1097	1097,0	5,0	5,0	405	
367,27	160	190	900	918	957,0	-	1072	1072,0	4,0	4,0	160	
560,09	160	190		918	957,0	-	7072	1072,0	4,0	4,0	208	
881,92	145	170		923	982,0	-	1127	1127,0	5,0	5,0	472	
379,46	145	170	950	968	1012,0	-	1132	1132,0	4,0	4,0	185	
590,28	145	170		968	1012,0	-	1132	1132,0	4,0	4,0	240	
968,18	135	160		978	1033,0	-	1222	1222,0	6,0	6,0	565	
444,27	135	160	1000	1023	1063,0	-	1197	1197,0	5,0	5,0	230	
687,14	135	160		1023	1063,0	-	1197	1197,0	5,0	5,0	310	
1 087,33	125	150		1028	1091,0	-	1292	1292,0	6,0	6,0	680	

Double row full complement cylindrical roller bearings d = 20 to 400 mm

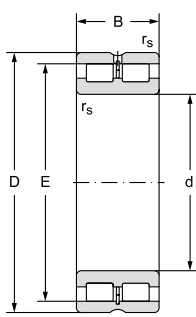

NNSL



NNSF



NNS

12.4.4

Main dimensions						Basic load rating		Fatigue load limit
d	D	B	r _s min	E	s ¹⁾	dynamic C _r	static C _{or}	P _u
mm						kN		kN
20	42	30	0,6	36,81	1,0	47,0	56,0	6,83
25	47	30	0,6	42,51	1,0	54,0	70,0	8,54
30	55	34	1,0	49,60	1,5	69,0	88,0	10,73
35	62	36	1,0	55,52	1,5	83,0	112,0	13,66
40	68	38	1,0	61,74	1,5	101,0	139,0	16,95
45	75	40	1,0	66,85	1,5	107,0	156,0	19,02
50	80	40	1,0	72,23	1,5	137,0	197,0	24,02
55	90	46	1,1	83,54	1,5	184,0	280,0	34,15
60	85	25	1,0	77,51	1,0	74,0	136,0	16,59
	85	25	1,0	77,51	-	74,0	136,0	16,59
	85	25	1,0	77,51	1,0	74,0	136,0	16,59
	95	46	1,1	86,74	1,5	192,0	300,0	36,59
65	100	46	1,1	93,09	1,5	203,0	325,0	39,63
70	100	30	1,0	91,87	1,0	109,0	193,0	23,54
	100	30	1,0	91,87	-	109,0	193,0	23,54
	100	30	1,0	91,87	1,0	109,0	193,0	23,54
	110	54	1,1	100,28	3,0	231,0	345,0	42,07
75	115	54	1,1	107,90	3,0	245,0	380,0	31,05
80	110	30	1,0	100,78	1,0	115,0	215,0	17,57
	110	30	1,0	100,78	-	115,0	215,0	17,57
	110	30	1,0	100,78	1,0	115,0	215,0	17,57
	125	60	1,1	116,99	3,5	300,0	455,0	36,34
85	130	60	1,1	121,44	3,5	305,0	475,0	37,40
90	125	35	1,1	115,20	1,5	155,0	300,0	23,62
	125	35	1,1	115,20	-	155,0	300,0	23,62
	125	35	1,1	115,20	1,5	155,0	300,0	23,62
	140	67	1,5	130,11	4,0	360,0	560,0	43,21

d = 20 to 90 mm

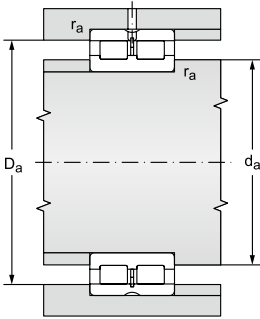

¹⁾ Admissible axial movement

²⁾ Recommended diameter of fitting for axially loaded bearings



Limiting speed for lubrication with		Bearing designation	Abutment and fillet dimensions					Lubrication slot and holes		Weight
grease	oil		d	d _o	d ₃₅ ²⁾	D _o	r _o	a	b	
min ⁻¹			mm							kg
7000	8300	NNSF5004CV	20	23,2	26,6	38,8	0,6	3,0	4,5	0,20
5700	6800	NNSF5005CV	25	28,2	28,2	43,8	0,6	3,0	4,5	0,23
6200	7300	NNSF5006CV	30	34,6	34,6	50,4	1,0	3,0	4,5	0,35
4300	5100	NNSF5007CV	35	39,6	39,6	57,4	1,0	3,0	4,5	0,46
3900	4600	NNSF5008CV	40	44,6	44,6	63,4	1,0	3,0	4,5	0,56
3400	4100	NNSF5009CV	45	49,6	49,6	70,4	1,0	3,0	4,5	0,71
3200	3800	NNSF5010CV	50	54,6	54,6	75,4	1,0	3,0	4,5	0,76
2700	3200	NNSF5011CV	55	61	61	84	1,0	3,5	4,5	1,16
2800	3400	NNSF4912CV	60	64,6	68,5	80,4	1,0	3,5	4,5	0,48
2800	3400	NNS4912CV		64,6	68,5	80,4	1,0	3,5	4,5	0,48
2800	3400	NNSL4912CV		64,6	-	80,4	1,0	3,5	4,5	0,48
2700	3200	NNSF5012CV		66	69,2	89	1,0	3,5	4,5	1,24
2400	2900	NNSF5013CV	65	71	71	94	1,0	3,5	4,5	1,32
2400	2900	NNSF4914CV	70	74,6	80,4	95,4	1,0	3,5	4,5	0,77
2400	2900	NNS4914CV		74,6	80,4	95,4	1,0	3,5	4,5	0,77
2400	2900	NNSL4914CV		74,6	-	95,4	1,0	3,5	4,5	0,77
2200	2700	NNSF5014CV		76	78,9	104	1,0	3,5	5,0	1,85
2100	2500	NNSF5015CV	75	81	81	109	1,0	3,5	5,0	1,93
2100	2500	NNSF4916CV	80	84,6	89,4	105,4	1,0	3,5	5,0	0,87
2100	2500	NNS4916CV		84,6	89,4	105,4	1,0	3,5	5,0	0,87
2100	2500	NNSL4916CV		84,6	-	105,4	1,0	3,5	5,0	0,87
1950	2300	NNSF5016CV		86	92	119	1,0	3,5	5,0	2,59
1950	2300	NNSF5017CV	85	91	91	124	1,0	3,5	5,0	2,72
1950	2300	NNSF4918CV	90	96	101	119	1,0	3,5	5,0	1,33
1950	2300	NNS4918CV		96	101	119	1,0	3,5	5,0	1,33
1950	2300	NNSL4918CV		96	-	119	1,0	3,5	5,0	1,33
1700	2100	NNSF5018CV		97	103	133	1,5	3,5	5,0	3,62

Double row full complement cylindrical roller bearings

d = 100 to 160 mm

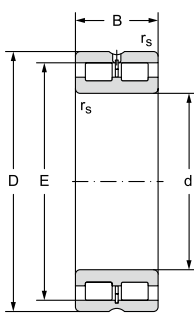

NNSL

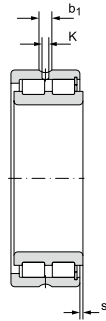

NNSF



NNS

12.4.4

Main dimensions						Basic load rating		Fatigue load limit
d	D	B	r _s	E	s ¹⁾	dynamic C _r	static C _{or}	P _u
mm						kN		kN
100	140	40	1,1	129,60	2,0	200,0	400,0	30,47
	140	40	1,1	129,60	-	200,0	400,0	30,47
	140	40	1,1	129,60	2,0	200,0	400,0	30,47
	150	67	1,5	139,65	4,0	380,0	620,0	46,65
110	150	40	1,1	138,20	2,0	210,0	430,0	31,98
	150	40	1,1	138,20	-	210,0	430,0	31,98
	150	40	1,1	138,20	2,0	210,0	430,0	31,98
	170	80	2,0	156,13	5,0	500,0	800,0	58,19
120	165	45	1,1	153,55	3,0	230,0	480,0	34,73
	165	45	1,1	153,55	-	230,0	480,0	34,73
	165	45	1,1	153,55	3,0	230,0	480,0	34,73
	180	80	2,0	167,58	5,0	530,0	880,0	62,69
130	180	50	1,5	165,40	4,0	265,0	530,0	37,39
	180	50	1,5	165,40	-	265,0	530,0	37,39
	180	50	1,5	165,40	4,0	265,0	530,0	37,39
	200	95	2,0	183,81	5,0	750,0	1250,0	86,54
140	190	50	1,5	175,90	4,0	275,0	570,0	39,46
	190	50	1,5	175,90	-	275,0	570,0	39,46
	190	50	1,5	175,90	4,0	275,0	570,0	39,46
	210	95	2,0	197,82	5,0	800,0	1370,0	93,19
150	190	40	1,1	178,30	2,0	245,0	585,0	40,14
	190	40	1,1	178,30	-	245,0	585,0	40,14
	190	40	1,1	178,30	2,0	245,0	585,0	40,14
	210	60	2,0	192,77	4,0	420,0	830,0	55,98
	210	60	2,0	192,77	-	420,0	830,0	55,98
	210	60	2,0	192,77	4,0	420,0	830,0	55,98
	225	100	2,0	206,80	6,0	830,0	1430,0	95,28
160	200	40	1,1	186,90	2,0	245,0	610,0	41,14
	200	40	1,1	186,90	-	245,0	610,0	41,14
	200	40	1,1	186,90	2,0	245,0	610,0	41,14
	220	60	2,0	206,16	4,0	435,0	910,0	60,39
	220	60	2,0	206,16	-	435,0	910,0	60,39
	220	60	2,0	206,16	4,0	435,0	910,0	60,39
	240	109	2,1	224,80	6,0	940,0	1600,0	104,56

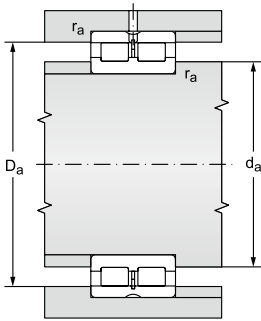

¹⁾ Admissible axial movement

²⁾ Recommended diameter of fitting for axially loaded bearings



Limiting speed for lubrication with		Bearing designation	Abutment and fillet dimensions					Lubrication slot and holes		Weight
grease	oil		d	d _o	d ₃₅ ²⁾	D _o	r _o	a	b	
min ⁻¹			mm						kg	
1600	1900	NNSF4920CV	100	106	114	134	1,0	3,5	5,0	1,93
1600	1900	NNS4920CV		106	114	134	1,0	3,5	5,0	1,93
1600	1900	NNSL4920CV		106	-	134	1,0	3,5	5,0	1,93
1600	1900	NNSF5020CV		107	112	143	1,5	3,5	6,0	3,94
1500	1800	NNSF4922CV	110	116	122	144	1,0	3,5	6,0	2,13
1500	1800	NNS4922CV		116	122	144	1,0	3,5	6,0	2,13
1500	1800	NNSL4922CV		116	-	144	1,0	3,5	6,0	2,13
1450	1700	NNSF5022CV		120	124	160	2,0	3,5	6,0	6,32
1350	1600	NNSF4924CV	120	126	136	159	1,0	3,5	6,0	2,90
1350	1600	NNS4924CV		126	136	159	1,0	3,5	6,0	2,90
1350	1600	NNSL4924CV		126	-	159	1,0	3,5	6,0	2,90
1350	1600	NNSF5024CV		130	135	170	2,0	3,5	6,0	6,77
1270	1500	NNSF4926CV	130	137	146	173	1,5	3,5	6,0	3,90
1270	1500	NNS4926CV		137	146	173	1,5	3,5	6,0	3,90
1270	1500	NNSL4926CV		137	-	173	1,5	3,5	6,0	3,90
1190	1400	NNSF5026CV		140	140	190	2,0	4,0	7,0	10,2
1190	1400	NNSF4928CV	140	147	156	183	1,5	3,5	6,0	4,15
1190	1400	NNS4928CV		147	156	183	1,5	3,5	6,0	4,20
1190	1400	NNSL4928CV		147	-	183	1,5	3,5	6,0	4,10
1100	1300	NNSF5028CV		150	150	200	2,0	4,0	7,0	11,1
1190	1400	NNSF4830CV	150	156	163	184	1,0	4,0	7,0	2,80
1190	1400	NNS4830CV		156	163	184	1,0	4,0	7,0	2,90
1190	1400	NNSL4830CV		156	-	184	1,0	4,0	7,0	2,70
1100	1300	NNSF4930CV		160	167	200	2,0	4,0	7,0	6,55
1100	1300	NNS4930CV		160	167	200	2,0	4,0	7,0	6,65
1100	1300	NNSL4930CV		160	-	200	2,0	4,0	7,0	6,45
1020	1200	NNSF5030CV		160	160	215	2,0	4,0	7,0	13,3
1100	1300	NNSF4832CV	160	166	171	194	1,0	4,0	7,0	3,00
1100	1300	NNS4832CV		166	171	194	1,0	4,0	7,0	3,10
1100	1300	NNSL4832CV		166	-	194	1,0	4,0	7,0	2,90
1020	1200	NNSF4932CV		170	181	210	2,0	4,0	7,0	6,90
1020	1200	NNS4932CV		170	181	210	2,0	4,0	7,0	7,00
1020	1200	NNSL4932CV		170	-	210	2,0	4,0	7,0	6,80
930	1100	NNSF5032CV		171	171	229	2,0	4,0	7,0	16,2

Double row full complement cylindrical roller bearings

d = 170 to 220 mm

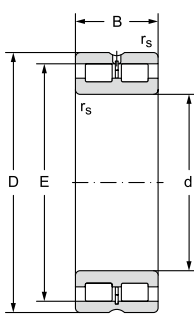

NNSL

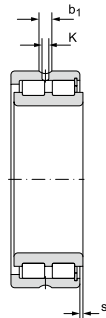

NNSF



NNS

12.4.4

Main dimensions						Basic load rating		Fatigue load limit
d	D	B	r _s	E	s ¹⁾	dynamic C _r	static C _{or}	P _u
mm						kN		kN
170	215	45	1,1	201,30	3,0	270,0	650,0	42,97
	215	45	1,1	201,30	-	270,0	650,0	42,97
	215	45	1,1	201,30	3,0	270,0	650,0	42,97
	230	60	2,0	215,08	4,0	450,0	950,0	62,08
	230	60	2,0	215,08	-	450,0	950,0	62,08
	230	60	2,0	215,08	4,0	450,0	950,0	62,08
	260	122	2,1	243,00	6,0	1200,0	2100,0	134,29
180	225	45	1,1	214,10	3,0	290,0	695,0	45,25
	225	45	1,1	214,10	-	290,0	695,0	45,25
	225	45	1,1	214,10	3,0	485,0	695,0	45,25
	250	69	2,0	230,50	4,0	580,0	1220,0	78,02
	250	69	2,0	230,50	-	580,0	1220,0	78,02
	250	69	2,0	230,50	4,0	580,0	1220,0	78,02
	280	136	2,1	260,50	8,0	1400,0	2500,0	156,67
190	240	50	1,5	225,00	4,0	320,0	750,0	47,96
	240	50	1,5	225,00	-	320,0	750,0	47,96
	240	50	1,5	225,00	4,0	320,0	750,0	47,96
	260	69	2,0	240,70	4,0	590,0	1290,0	81,38
	260	69	2,0	240,70	-	590,0	1290,0	81,38
	260	69	2,0	240,70	4,0	590,0	1290,0	81,38
	290	136	2,1	270,00	8,0	1450,0	2600,0	160,87
200	250	50	1,5	235,50	4,0	325,0	800,0	50,47
	250	50	1,5	235,50	-	325,0	800,0	50,47
	250	50	1,5	235,50	4,0	325,0	800,0	50,47
	280	80	2,1	259,34	5,0	690,0	1500,0	92,81
	280	80	2,1	259,34	-	690,0	1500,0	92,81
	280	80	2,1	259,34	5,0	690,0	1500,0	92,81
	310	150	2,1	288,00	9,0	1650,0	3050,0	185,31
220	270	50	1,5	256,50	4,0	340,0	860,0	52,88
	270	50	1,5	256,50	-	340,0	860,0	52,88
	270	50	1,5	256,50	4,0	340,0	860,0	52,88
	300	80	2,1	276,52	5,0	725,0	1600,0	96,65
	300	80	2,1	276,52	-	725,0	1600,0	96,65
	300	80	2,1	276,52	5,0	725,0	1600,0	96,65
	340	160	3,0	312,20	9,0	2000,0	3600,0	212,68

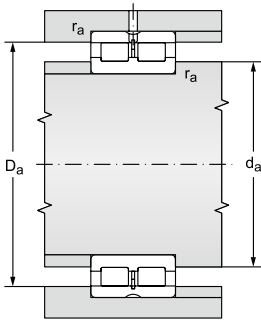

¹⁾ Admissible axial movement
²⁾ Recommended diameter of fitting for axially loaded bearings



Limiting speed for lubrication with		Bearing designation	Abutment and fillet dimensions					Lubrication slot and holes		Weight
grease	oil		d	d _o	d ₃₅ ²⁾	D _o	r _o	a	b	
min ⁻¹			mm						kg	
1120	1200	NNSF4834CV	170	176	184	209	1,0	4,0	7,0	4,00
1020	1200	NNS4834CV		176	184	209	1,0	4,0	7,0	4,10
1020	1200	NNSL4834CV		176	-	209	1,0	4,0	7,0	3,90
930	1100	NNSF4934CV		180	190	220	2,0	4,0	7,0	7,20
930	1100	NNS4934CV		180	190	220	2,0	4,0	7,0	7,35
930	1100	NNSL4934CV		180	-	220	2,0	4,0	7,0	7,10
850	1000	NNSF5034CV		181	181	249	2,0	4,0	7,0	23,0
930	1100	NNSF4836CV	180	186	197	219	1,0	4,0	7,0	4,20
930	1100	NNS4836CV		186	197	219	1,0	4,0	7,0	4,30
930	1100	NNSL4836CV		186	-	219	1,0	4,0	7,0	4,10
850	1000	NNSF4936CV		190	202	240	2,0	4,0	7,0	10,7
850	1000	NNS4936CV		190	202	240	2,0	4,0	7,0	10,8
850	1000	NNSL4936CV		190	-	240	2,0	4,0	7,0	10,5
850	1000	NNSF5036CV		191	206	269	2,0	4,0	8,0	30,5
850	1000	NNSF4838CV	190	197	206	233	1,5	4,0	7,0	5,50
850	1000	NNS4838CV		197	206	233	1,5	4,0	7,0	5,65
850	1000	NNSL4838CV		197	-	233	1,5	4,0	7,0	5,30
850	1000	NNSF4938CV		200	212	250	2,0	4,0	7,0	11,1
850	1000	NNS4938CV		200	212	250	2,0	4,0	7,0	11,2
850	1000	NNSL4938CV		200	-	250	2,0	4,0	7,0	10,9
800	950	NNSF5038CV		201	201	279	2,0	4,0	8,0	31,5
850	1000	NNSF4840CV	200	207	217	243	1,5	4,0	7,0	5,80
850	1000	NNS4840CV		207	217	243	1,5	4,0	7,0	5,90
850	1000	NNSL4840CV		207	-	243	1,5	4,0	7,0	5,70
800	950	NNSF4940CV		211	227	269	2,0	4,0	8,0	15,6
800	950	NNS4940CV		211	227	269	2,0	4,0	8,0	15,8
800	950	NNSL4940CV		211	-	269	2,0	4,0	8,0	15,3
800	950	NNSF5040CV		211	230	299	2,0	4,0	8,0	41,0
800	950	NNSF4844CV	220	227	238	263	1,5	4,0	7,0	6,30
800	950	NNS4844CV		227	238	263	1,5	4,0	7,0	6,40
800	950	NNSL4844CV		227	-	263	1,5	4,0	7,0	6,20
800	950	NNSF4944CV		231	244	289	2,0	4,0	8,0	17,0
800	950	NNS4944CV		231	244	289	2,0	4,0	8,0	17,2
800	950	NNSL4944CV		231	-	289	2,0	4,0	8,0	16,8
720	850	NNSF5044CV		235	248	325	2,5	6,0	8,0	52,5

Double row full complement cylindrical roller bearings

d = 240 to 320 mm

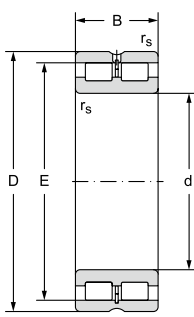

NNSL

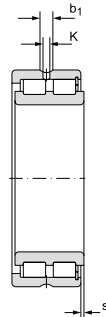

NNSF



NNS

12.4.4

Main dimensions						Basic load rating		Fatigue load limit
d	D	B	r _s	E	s ¹⁾	dynamic C _r	static C _{or}	P _u
mm						kN		kN
240	300	60	2,0	281,90	4,0	530,0	1290,0	77,05
	300	60	2,0	281,90	-	530,0	1290,0	77,05
	300	60	2,0	281,90	4,0	530,0	1290,0	77,05
	320	80	2,1	299,46	5,0	770,0	1750,0	103,39
	320	80	2,1	299,46	-	770,0	1750,0	103,39
	320	80	2,1	299,46	5,0	770,0	1750,0	103,39
	360	160	3,0	335,60	9,0	2100,0	3900,0	225,68
260	320	60	2,0	304,20	4,0	550,0	1400,0	81,84
	320	60	2,0	304,20	-	550,0	1400,0	81,84
	320	60	2,0	304,20	4,0	550,0	1400,0	81,84
	360	100	2,1	331,33	6,0	1150,0	2550,0	146,12
	360	100	2,1	331,33	-	1150,0	2550,0	146,12
	360	100	2,1	331,33	6,0	1150,0	2550,0	146,12
	400	190	4,0	373,50	10,0	2850,0	5100,0	286,80
280	350	69	2,0	332,40	4,0	720,0	1850,0	105,50
	350	69	2,0	332,40	-	720,0	1850,0	105,50
	350	69	2,0	332,40	4,0	720,0	1850,0	105,50
	380	100	2,1	353,34	6,0	1200,0	2700,0	151,84
	380	100	2,1	353,34	-	1200,0	2700,0	151,84
	380	100	2,1	353,34	6,0	1200,0	2700,0	151,84
	420	190	4,0	389,00	10,0	2900,0	5300,0	292,84
300	380	80	2,1	356,70	6,0	850,0	2100,0	117,04
	380	80	2,1	356,70	-	850,0	2100,0	117,04
	380	80	2,1	356,70	6,0	850,0	2100,0	117,04
	420	118	3,0	385,51	6,0	1650,0	3750,0	205,45
	420	118	3,0	385,51	-	1650,0	3750,0	205,45
	420	118	3,0	385,51	6,0	1650,0	3750,0	205,45
	460	218	4,0	433,00	9,0	3250,0	6550,0	353,08
320	400	80	2,1	379,70	6,0	890,0	2280,0	124,91
	400	80	2,1	379,70	-	890,0	2280,0	124,91
	400	80	2,1	379,70	6,0	890,0	2280,0	124,91
	440	118	3,0	412,27	6,0	1750,0	4050,0	218,32
	440	118	3,0	412,27	-	1750,0	4050,0	218,32
	440	118	3,0	412,27	6,0	1750,0	4050,0	218,32
	480	218	4,0	449,00	9,0	3650,0	6950,0	368,92

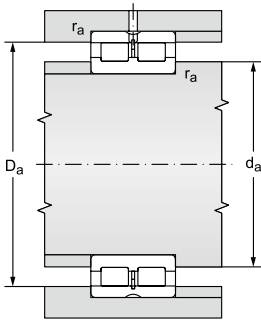

¹⁾ Admissible axial movement

²⁾ Recommended diameter of fitting for axially loaded bearings



Limiting speed for lubrication with		Bearing designation	Abutment and fillet dimensions					Lubrication slot and holes		Weight
grease	oil		d	d _o	d ₃₅ ²⁾	D _o	r _o	a	b	
min ⁻¹			mm						kg	
760	900	NNSF4848CV	240	250	257	290	2,0	4,0	8,0	9,90
760	900	NNS4848CV		250	257	290	2,0	4,0	8,0	10,00
760	900	NNSL4848CV		250	-	290	2,0	4,0	8,0	9,80
720	850	NNSF4948CV		251	267	309	2,0	4,0	8,0	18,3
720	850	NNS4948CV		251	267	309	2,0	4,0	8,0	18,5
720	850	NNSL4948CV		251	-	309	2,0	4,0	8,0	17,9
680	800	NNSF5048CV		255	271	345	2,5	5,0	9,4	56,0
680	800	NNSF4852CV	260	270	280	310	2,0	4,0	8,0	10,8
680	800	NNS4852CV		270	280	310	2,0	4,0	8,0	11,0
680	800	NNSL4852CV		270	-	310	2,0	4,0	8,0	10,6
630	750	NNSF4952CV		271	290	349	2,0	5,0	9,4	31,6
630	750	NNS4952CV		271	290	349	2,0	5,0	9,4	32,0
630	750	NNSL4952CV		271	-	349	2,0	5,0	9,4	31,2
590	700	NNSF5052CV		278	297	382	3,0	5,0	9,4	85,5
630	750	NNSF4856CV	280	290	305	340	2,0	4,0	8,0	15,8
630	750	NNS4856CV		290	305	340	2,0	4,0	8,0	16,0
630	750	NNSL4856CV		290	-	340	2,0	4,0	8,0	15,6
590	700	NNSF4956CV		291	312	369	2,0	5,0	9,4	33,5
590	700	NNS4956CV		291	312	369	2,0	5,0	9,4	34,0
590	700	NNSL4956CV		291	-	369	2,0	5,0	9,4	33,0
570	670	NNSF5056CV		298	314	402	3,0	5,0	9,4	90,5
590	700	NNSF4860CV	300	311	325	369	2,0	5,0	9,4	22,5
590	700	NNS4860CV		311	325	369	2,0	5,0	9,4	23,0
590	700	NNSL4860CV		311	-	369	2,0	5,0	9,4	22,0
570	670	NNSF4960CV		315	335	405	2,5	5,0	9,4	52,5
570	670	NNS4960CV		315	335	405	2,5	5,0	9,4	53,0
570	670	NNSL4960CV		315	-	405	2,5	5,0	9,4	52,0
510	600	NNSF5060CV		318	343	442	3,0	5,0	9,4	130
530	630	NNSF4864CV	320	331	348	389	2,0	5,0	9,4	23,5
530	630	NNS4864CV		331	348	389	2,0	5,0	9,4	24,0
530	630	NNSL4864CV		331	-	389	2,0	5,0	9,4	23,0
510	600	NNSF4964CV		335	362	425	2,5	5,0	9,4	55,5
510	600	NNS4964CV		335	362	425	2,5	5,0	9,4	56,0
510	600	NNSL4964CV		335	-	425	2,5	5,0	9,4	55,0
470	560	NNSF5064CV		338	360	462	3,0	5,0	9,4	135

Double row full complement cylindrical roller bearings

d = 340 to 400 mm

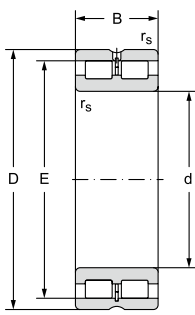

NNSL

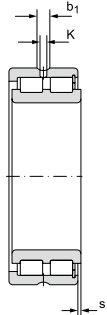

NNSF



NNS

12.4.4

Main dimensions						Basic load rating		Fatigue load limit
d	D	B	r _s	E	s ¹⁾	dynamic C _r	static C _{or}	P _u
mm						kN		kN
340	420	80	2,1	396,90	6,0	900,0	2400,0	129,37
	420	80	2,1	396,90	-	900,0	2400,0	129,37
	420	80	2,1	396,90	6,0	900,0	2400,0	129,37
	460	118	3,0	430,11	6,0	1780,0	4250,0	225,60
	460	118	3,0	430,11	-	1780,0	4250,0	225,60
	460	118	3,0	430,11	6,0	1780,0	4250,0	225,60
	520	243	5,0	485,00	11,0	4350,0	8300,0	431,13
360	440	80	2,1	419,80	6,0	925,0	2550,0	135,36
	440	80	2,1	419,80	-	925,0	2550,0	135,36
	440	80	2,1	419,80	6,0	925,0	2550,0	135,36
	480	118	3,0	448,00	6,0	1820,0	4500,0	235,40
	480	118	3,0	448,00	-	1820,0	4500,0	235,40
	480	118	3,0	448,00	6,0	1820,0	4500,0	235,40
	540	243	5,0	503,00	11,0	4450,0	8650,0	443,22
380	480	100	2,1	455,80	6,0	1400,0	3650,0	189,59
	480	100	2,1	455,80	-	1400,0	3650,0	189,59
	480	100	2,1	455,80	6,0	1400,0	3650,0	189,59
	520	140	4,0	481,35	7,0	2350,0	5700,0	292,06
	520	140	4,0	481,35	-	2350,0	5700,0	292,06
	520	140	4,0	481,35	7,0	2350,0	5700,0	292,06
	560	243	5,0	521,00	11,0	4650,0	9150,0	462,76
400	500	100	2,1	470,59	6,0	1420,0	3750,0	192,15
	500	100	2,1	470,59	-	1420,0	3750,0	192,15
	500	100	2,1	470,59	6,0	1420,0	3750,0	192,15
	540	140	4,0	501,74	7,0	2400,0	6000,0	303,45
	540	140	4,0	501,74	-	2400,0	6000,0	303,45
	540	140	4,0	501,74	7,0	2400,0	6000,0	303,45
	600	272	5,0	558,00	11,0	5500,0	11000,0	546,10

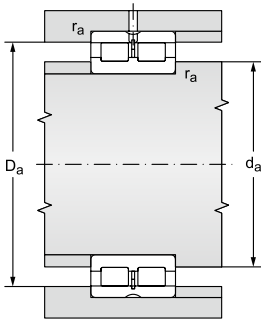

¹⁾ Admissible axial movement

²⁾ Recommended diameter of fitting for axially loaded bearings



Limiting speed for lubrication with		Bearing designation	Abutment and fillet dimensions					Lubrication slot and holes		Weight
grease	oil		d	d _o	d ₂₅ ²⁾	D _o	r _o	a	b	
min ⁻¹			mm						kg	
510	600	NNSF4868CV	340	351	365	409	2,0	5,0	9,4	25,0
510	600	NNS4868CV		351	365	409	2,0	5,0	9,4	25,5
510	600	NNSL4868CV		351	-	409	2,0	5,0	9,4	24,5
470	560	NNSF4968CV		355	380	445	2,5	5,0	9,4	58,5
470	560	NNS4968CV		355	380	445	2,5	5,0	9,4	59,0
470	560	NNSL4968CV		355	-	445	2,5	5,0	9,4	57,8
450	530	NNSF5068CV		361	384	497	4,0	5,0	9,4	185
470	560	NNSF4872CV	360	371	388	429	2,0	5,0	9,4	26,5
470	560	NNS4872CV		371	388	429	2,0	5,0	9,4	27,0
470	560	NNSL4872CV		371	-	429	2,0	5,0	9,4	26,0
450	530	NNSF4972CV		375	398	465	2,5	5,0	9,4	61,5
450	530	NNS4972CV		375	398	465	2,5	5,0	9,4	62,0
450	530	NNSL4972CV		375	-	465	2,5	5,0	9,4	60,8
420	500	NNSF5072CV		383	402	517	4,0	5,0	9,4	195
450	530	NNSF4876CV	380	391	415	469	2,0	5,0	9,4	44,8
450	530	NNS4876CV		391	415	469	2,0	5,0	9,4	45,5
450	530	NNSL4876CV		391	-	469	2,0	5,0	9,4	44,0
420	500	NNSF4976CV		398	424	502	3,0	5,0	9,4	91,5
420	500	NNS4976CV		398	424	502	3,0	5,0	9,4	92,5
420	500	NNSL4976CV		398	-	502	3,0	5,0	9,4	90,5
400	480	NNSF5076CV		403	420	537	4,0	5,0	9,4	200
420	500	NNSF4880CV	400	411	430	489	2,0	5,0	9,4	46,2
420	500	NNS4880CV		411	430	489	2,0	5,0	9,4	46,5
420	500	NNSL4880CV		411	-	489	2,0	5,0	9,4	45,9
400	480	NNSF4980CV		418	444	522	3,0	5,0	9,4	95,5
400	480	NNS4980CV		418	444	522	3,0	5,0	9,4	96,5
400	480	NNSL4980CV		418	-	522	3,0	5,0	9,4	94,5
380	450	NNSF5080CV		423	449	577	4,0	5,0	9,4	270





TKL

22322EW

12.5 SPHERICAL ROLLER BEARINGS

Double row spherical roller bearings have two rows of spherical rollers with common spherical track in outer ring. This structure allows mutual tipping of rings. They can simultaneously transfer considerable radial and axial loads in both directions. Bearings are made with cylindrical and tapered bore. These bearings are suitable for locations where big loads act, and tipability has to be ensured bearings can thus eliminate movement and misalignment of shaft. Bearings that are manufactured in the NEW FORCE standard are marked with ** in the table section of the catalogue.

Construction design

In the standard assortment, ZKL offer spherical roller bearings in several versions that differ in the structure of the inner ring, cage and cage guidance.

- EMH** bearings with optimised design with symmetrical spherical rollers that brings higher load bearing capacity. Single piece crest massive brass cage led on the internal ring (fig. 12.5.1), in series 222 for bore diameter $d \leq 160$ mm, and in series 223 for bore diameter $d \leq 130$ mm the cage is led on spherical rollers (fig. 12.5.2).

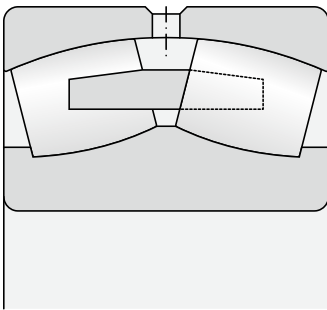

Fig. 12.5.1

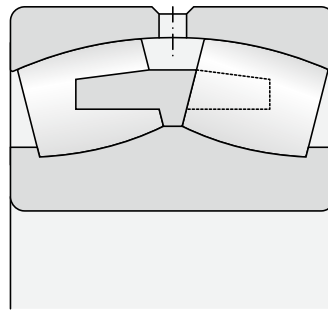

Fig. 12.5.2

- CJ** bearings with optimised design with symmetrical spherical rollers that brings higher load bearing capacity. Bearings have two cages pressed of steel plate with hardened surface that are guided by floating guide ring between both rows of spherical rollers centred on the inner ring (fig. 12.5.3).
- EJ** bearings with optimised structure with symmetrical spherical rollers that brings higher load bearing capacity. Bearings have two cages pressed of steel plate with hardened surface. Bearing do not have a guide ring (fig. 12.5.4).

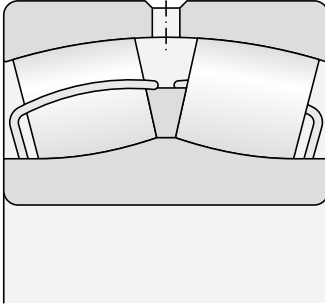

Fig. 12.5.3

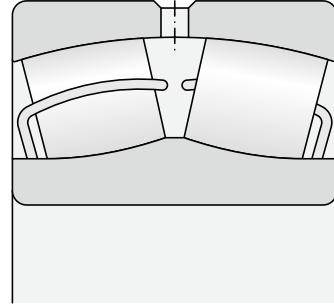

Fig. 12.5.4

Bearings in M and CM design are successively upgraded and replaced with types featuring optimised inner structure EMH, alternatively with bearings provided with EJ and CJ sheet metal cage.

- M** bearings have asymmetrical spherical rollers and two massive brass cages guided on fixed central flange of the inner ring.
- CM** bearings with optimised inner design featuring higher load bearing capacity and symmetrical spherical rollers. Bearings have two massive brass cages guided on fixed central flange of the inner ring (fig. 12.5.5).

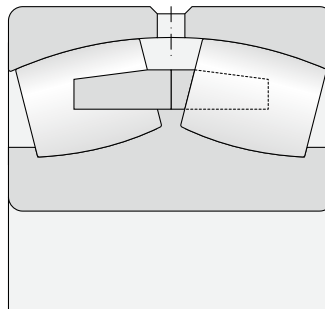

Fig. 12.5.5

Tapered hole

Bearings with tapered bore have taper size 1:12 (additional designation **K**); the size of taper in series 240, 241, 248 and 249 is 1:30 (additional designation **K30**). Bearings with tapered bore are mounted on roller shafts by adapter sleeve (fig. 10.8) or withdrawal sleeve (fig. 10.9). The system of designating the sleeves to individual bearing types is stated in the table section of the publication.

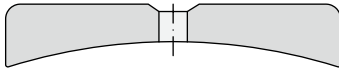

Fig. 12.5.6

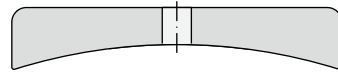

Fig. 12.5.7

Lubrication groove and holes on outer ring



In order to achieve better lubrication and higher reliability, double row spherical roller bearings are usually manufactured with a groove on the circumference of the outer ring, and three lubrication holes, except for the 238 and 248 series. This version has additional designation **W33** (fig. 12.5.6). Bearings of series have only three lubrication bores in the outer ring without a groove, additional designation **W20** (fig. 12.5.7).

Upon customer's request bearings can be supplied in a design without the groove and lubrication holes in the outer ring, alternatively bearings can be modified for lubrication through the inner ring. These modifications have to be discussed with the supplier.

Bearings for vibrating machines and equipment

To enhance reliability in environment with increased vibration level and strokes, double row spherical roller bearings of series 223 or 233 are manufactured under designation **EMHD2** (fig. 12.5.8). These bearings feature higher load bearing capacity and symmetrical spherical rollers, single piece massive brass cage is guided on the outer ring. As standard, the bearings have radial clearance within C4 and narrowed connecting dimension tolerances of the bore (in bearings with cylindrical bore) and outer diameter (see Table 12.5.1). As standard, outer rings have circumferential groove with three lubrication bores. Increased radial clearance, as well as the way of cage guidance and groove with lubrication bores, is not specially identified in these bearings; it is contained in the combined designation D2.

The bearings are designed for heavy service conditions, specifically:

- vibrating machines
- shake-out sieves and grates
- traction machines

We recommend the selection and way of locating them in are discussed with the technical & consulting services workers of the ZKL's Technical & Consultancy service.

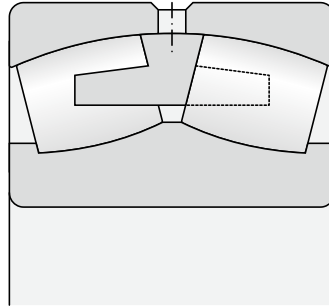

Fig. 12.5.8

Tab. 12.5.1

Inner ring					
Bore diameter [mm]	over	30	50	80	120
	incl.	50	80	120	180
Tolerance ΔD_{mp} [μm]		0	0	0	0
		-7	-9	-12	-15
Outer ring					
Bore diameter [mm]	over	80	150	180	315
	incl.	150	180	315	400
Tolerance ΔD_{mp} [μm]		-5	-5	-10	-13
		-13	-18	-23	-28

NEW FORCE bearings

Bearings in the NEW FORCE standard are marked with two stars** in the table section of the catalogue.

General information

Main dimensions

Main dimensions of bearings comply with the standard ISO 15 and for individual bearings are stated in the table section of the publication.

Accuracy

Double row spherical roller bearings are usually made in normal accuracy level P0 which is not presented. Supply of bearings with higher accuracy class has to be consulted with the supplier.

Radial clearance

Commonly produced bearings feature normal axial clearance that is not identified. Special locations require bearings with reduced C2 clearance, or with increased radial clearance C3, C4 and C5. The radial clearance values comply with the standard ISO 5753 for bearings with cylindrical and tapered bore, and are stated in charts 7.2 and 7.23.

Admissible misalignment

Bearings can be misaligned from central position without disturbing their proper function. Table 12.5.2 states allowed misalignment values by the type bearing series.

Tab. 12.5.2

Bearing series	Admissible misalignment
222, 230, 231, 238, 239, 248	1°30'
213, 223, 240	2°
232, 241, 249	2°30'



Effect of running temperature to bearing material

All ZKL spherical roller bearings are subjected to special heat treatment that allows their use in service temperature to 200 °C without inadmissible dimensional changes. Corresponding additional designation S1 is not stated. Exception is bearing in CJ design with sheet metal cages and polyamide guide ring, applicability of which is limited by properties of polyamide – see article Materials of roller bearings in chapter 7. More detailed information on specific bearing type is available at the Technical & Consultancy service of ZKL.

Running temperature and axial load

Double row spherical roller bearings can besides radial load transfer also considerable axial load. If the axial and radial load rate $F_a / F_r > e$ (coefficient stated in the table section), we recommend that the intervals for additional lubrication with grease are shortened. Running temperature may represent a limiting factor in terms of axial load. If this is the case, we recommend that you contact the Technical & Consultancy service of ZKL which will evaluate the suitability of selected bearing for particular location and service conditions.

Admissible axial load of bearings mounted on adapter sleeves

In the assembly of spherical roller bearings on smooth shafts (without fitting or another support surface) by means of adapter sleeves, it is possible to define the admissible axial load of the bearing based on the below relation, on condition of proper assembly.

$$F_{ap} = 3 \cdot B \cdot d$$

F_{ap} is the maximum admissible axial load [N]

B is the bearing width [mm]

d is the bearing bore diameter [mm]

Minimum load

Bearings must be exposed to certain minimum service load in order to ensure their smooth operation. This applies also to spherical roller bearings, mainly for operation at high revolutions at which inertia forces of spherical rollers, of cage and friction in lubricant may have negative impact on rolling, and may cause damage to spherical rollers and raceways. Minimum radial bearings can be in these cases approximately determined based on the below relation.

$$F_{rm} = 0.02 \cdot C_r$$

F_{rm} is the minimum radial load [kN]

C_r Is the basic dynamic load capacity [kN]

The weight of components loading the bearing, along with external acting forces, often exceeds the minimum load required. If this is not the case, the bearing has to be loaded with an additional force, e.g. by increasing the tension of the belt, increasing the torque at idle run, etc.

Equivalent dynamic load P_r

In order to carry out the calculation based on the basic durability equation, the actually acting load has to be converted to equivalent, i.e. implied distributed load which complies with the conditions applicable to the basic dynamic load bearing capacity, and has the same effect on the durability of the bearing as the actual load. To ensure correct calculation of this load we need to know as accurately as possible the outer forces acting on the bearing.

$$P_r = F_r + Y_1 \cdot F_a \quad \text{for } F_a / F_r \leq e \quad [\text{kN}]$$

$$P_r = 0.67 \cdot F_r + Y_2 \cdot F_a \quad \text{for } F_a / F_r > e \quad [\text{kN}]$$

F_r radial load [kN]

F_a axial load [kN]

The values of coefficients e , Y_1 and Y_2 for individual types of bearings are stated in the table section of the publication.

Equivalent static load P_{0r}

The continuity of equivalent static load and the actual, as well the definition of it, is similar to that of the equivalent dynamic load.

$$P_{0r} = F_r + Y_0 \cdot F_a$$

The values of coefficient Y_0 are for individual types of bearings stated in the table section of the publication.

Supplementary characters behind the basic bearing designation

The designation of bearing design and cage design is stated in the previous text of the chapter.

- C2** radial clearance smaller than normal
- C3** radial clearance bigger than normal
- C4** radial clearance bigger than C3
- C5** radial clearance bigger than C4
- K** inner ring with tapered bore, taper ratio 1:12
- K30** inner ring with tapered bore, taper ratio 01:30
- P6** higher than normal accuracy
- P63** example of combined designation (P6 + C3)
- W20** outer ring with three lubrication bores
- W33** outer ring with circumferential groove and three lubrication bores



Assembly of bearings with tapered bore

Bearings with tapered bore are mounted on relevant shaft always with certain overlap. This overlap has to be put in line with reduction of radial clearance of mounted bearing, or the inner ring on the tapered journal has to be shifted. In double row spherical roller bearings it is recommended to measure reduction of radial clearance of mounted bearing. Only in small bearings, or where limited spatial conditions are, axial movement is checked which however requires certain experience in determination of the initial position. Feeler gauges are used prior, during and after the assembly to measure radial clearance. Clearance has to be measured always between the outer ring raceway and the unloaded spherical roller. Prior to measuring, always spin the bearing several times to get the spherical rollers to proper position. Measured radial clearance must be identical for both rows of spherical rollers. The recommended reduced radial clearance and axial movement values are stated in chart 12.5.3. The minimum values of radial clearance stated in the chart are used for bearings with normal radial clearance close to the bottom limit of the defined clearance range. For C3 and C4 clearance bearings, such value of radial clearance reduction should be selected that lies in the proximity of the maximum value recommended.

Tab. 12.5.3

Assembly of double row spherical roller bearings with tapered bore										
Bore diameter		Radial clearance reduction		Axial displacement on taper 1:12				Minimum allowed radial clearance of bearing with clearance		
over	to	min	max	on shaft		on bushing		normal	C3	C4
				min	max	min	max			
mm		µm		mm				µm		
30	40	20	25	0,35	0,4	0,35	0,45	15	20	40
40	50	25	30	0,4	0,45	0,45	0,5	20	30	50
50	65	30	40	0,45	0,6	0,5	0,7	25	35	55
65	80	40	50	0,6	0,75	0,7	0,85	25	40	70
80	100	45	60	0,7	0,9	0,75	1	35	50	80
100	120	50	70	0,75	1,1	0,8	1,2	50	65	100
120	140	65	90	1,1	1,4	1,2	1,5	55	80	110
140	160	75	100	1,2	1,6	1,3	1,7	55	90	130
160	180	80	110	1,3	1,7	1,4	1,9	60	100	150
180	200	90	130	1,4	2	1,5	2,2	70	100	160
200	225	100	140	1,6	2,2	1,7	2,4	80	120	180
225	250	110	150	1,7	2,4	1,8	2,6	90	130	200
250	280	120	170	1,9	2,7	2	2,9	100	140	220
280	315	130	190	2	3	2,2	3,2	110	150	240
315	355	150	210	2,4	3,3	2,6	3,6	120	170	260
355	400	170	230	2,6	3,6	2,9	3,9	130	190	290
400	450	200	260	3,1	4,1	3,4	4,4	130	200	310
450	500	210	280	3,3	4,4	3,6	4,8	160	230	350
500	560	240	320	3,7	5	4,1	5,4	170	250	360
560	630	260	350	4	5,4	4,4	5,9	200	290	410
630	710	300	400	4,6	6,2	5,1	6,8	210	310	450
710	800	340	450	5,3	7	5,8	7,6	230	350	510
800	900	370	500	5,7	7,8	6,3	8,5	270	390	570

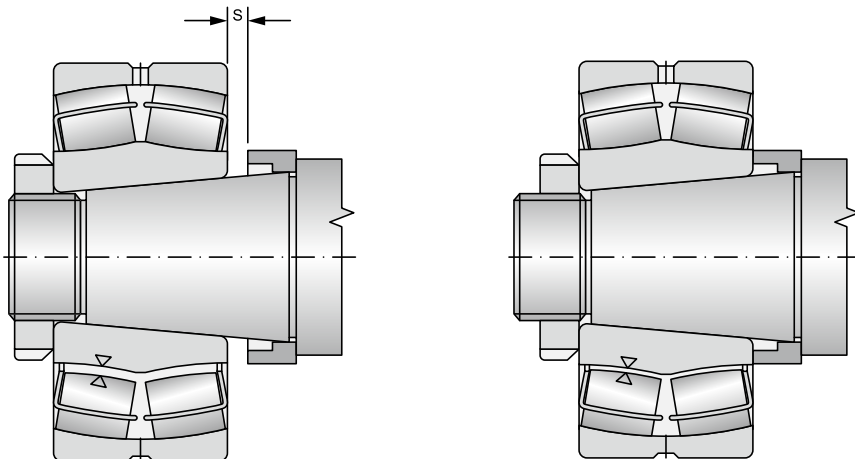
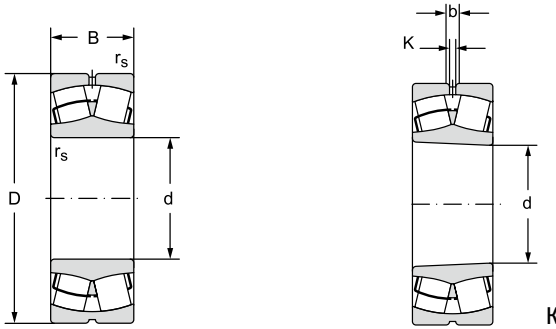

Fig. 12.5.9



Double row spherical roller bearings d = 25 to 1120 mm

d = 25 to 60 mm



12.5.1

Main dimensions						Basic load rating		Fatigue load limit	Limiting speed for lubrication with		Bearing designation	
d	D	B	r _s	a	b	dynamic C _r	static C _{0r}	P _u	grease	oil	with cylindrical bore	with tapered bore
mm						kN		kN	min ⁻¹			
25	52	18	1	2	3,7	47,5	50,2	6,1	8500	11000	22205EW33J**	22205EKW33J**
	62	17	1,1	-	-	48,8	44,3	5,4	6700	8500	21305CJ**	21305CKJ**
30	62	20	1	2	3,7	62,2	66,4	8,1	7500	9500	22206EW33J**	22206EKW33J**
	72	19	1,1	-	-	60,2	56,5	6,9	6000	7500	21306CJ**	21306CKJ**
35	72	23	1,1	2	3,7	82,6	93,5	11	6300	8000	22207EW33J**	22207EKW33J**
	80	21	1,5	-	-	77	77,8	9,5	5300	6700	21307CJ**	21307CKJ**
40	80	23	1,1	3	5,5	89,6	99,7	12	6000	7500	22208EW33J**	22208EKW33J**
	90	23	1,5	3	5,5	97,3	102	12	4500	5600	21308CW33J**	21308CKW33J**
	90	33	1,5	3	5,5	154	160	20	4100	5100	22308EW33J**	22308EKW33J**
	90	33	1,5	3	5,5	154	160	20	4100	5100	22308EW33MH**	22308EKW33MH**
45	85	23	1,1	3	5,5	95,6	110	13	5300	6700	22209EW33J**	22209EKW33J**
	100	25	1,5	3	5,5	118	125	15	4300	5300	21309CW33J**	21309CKW33J**
	100	36	1,5	3	5,5	184	194	24	3700	4500	22309EW33J**	22309EKW33J**
	100	36	1,5	3	5,5	184	194	24	3700	4500	22309EW33MH**	22309EKW33MH**
50	90	23	1,1	3	5,5	102	120	15	5000	6300	22210EW33J**	22210EKW33J**
	110	27	2	3	5,5	152	151	18	3600	4800	21310CW33J**	21310CKW33J**
	110	40	2	3	5,5	220	238	29	3300	4000	22310EW33J**	22310EKW33J**
	110	40	2	3	5,5	220	238	29	3300	4000	22310EW33MH**	22310EKW33MH**
55	100	25	1,5	3	5,5	137	147	18	4500	5600	22211EW33J**	22211EKW33J**
	100	25	1,5	3	5,5	137	147	18	4500	5600	22211EW33MH**	22211EKW33MH**
	120	29	2	3	5,5	163	176	22	3400	4300	21311CW33J**	21311CKW33J**
	120	43	2	3	5,5	253	279	34	3000	3800	22311EW33J**	22311EKW33J**
	120	43	2	3	5,5	253	279	34	3000	3800	22311EW33MH**	22311EKW33MH**
60	110	28	1,5	3	5,5	168	183	22	4000	5000	22212EW33J**	22212EKW33J**
	110	28	1,5	3	5,5	168	183	22	4000	5000	22212EW33MH**	22212EKW33MH**
	130	31	2,1	3	5,5	186	215	26	3000	3800	21312CW33J**	21312CKW33J**
	130	46	2,1	3	5,5	304	315	38	2800	3600	22312EW33J**	22312EKW33J**
	130	46	2,1	3	5,5	304	315	38	2800	3600	22312EW33MH**	22312EKW33MH**
	130	46	2,1	3	5,5	304	315	38	2800	3600	22312EMHD2**	22312EKMHD2**

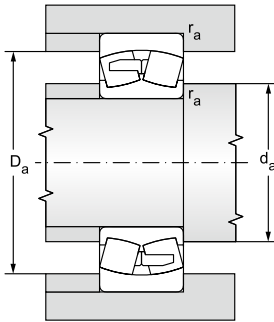

Abutment and fillet dimensions			Weight		Corresp. adapter sleeve	Corresp. withdrawal sleeve	Corresp. nut	Factors			
d _a	D _a	r _a	K					e	Y ₁	Y ₂	Y ₀
min	max	max									
mm			kg								
31	46	1	0,181	0,177	H305	-	-	0,34	2,0	3,0	2,0
32	55	1	0,270	0,265	H305	-	-	0,30	2,3	3,4	2,2
36	56	1	0,286	0,280	H306	-	-	0,31	2,2	3,2	2,1
37	65	1	0,400	0,390	H306	-	-	0,27	2,5	3,7	2,5
42	65	1	0,445	0,436	H307	-	-	0,31	2,2	3,3	2,2
44	71	1,5	0,540	0,530	H307	-	-	0,28	2,4	3,6	2,5
47	73	1	0,534	0,523	H308	AH308	KM9	0,27	2,5	3,7	2,4
49	81	1,5	0,744	0,733	H308	AH308	KM9	0,26	2,6	3,9	2,6
49	81	1,5	1,05	1,03	H2308	AH2308	KM9	0,36	1,8	2,6	1,8
49	81	1,5	1,07	1,05	H2308	AH2308	KM9	0,36	1,8	2,6	1,8
52	78	1	0,576	0,563	H309	AH309	KM10	0,25	2,7	4,0	2,6
54	91	1,5	0,990	0,975	H309	AH309	KM10	0,24	2,8	4,2	2,8
54	91	1,5	1,40	1,37	H2309	AH2309	KM10	0,36	1,9	2,8	1,9
54	91	1,5	1,43	1,40	H2309	AH2309	KM10	0,36	1,9	2,8	1,9
57	83	1	0,623	0,610	H310	AH310X	KM11	0,24	2,8	4,2	2,8
60	100	2	1,25	1,23	H310	AH310X	KM11	0,24	2,8	4,2	2,8
60	100	2	1,87	1,83	H2310	AH2310X	KM11	0,36	1,9	2,7	1,8
60	100	2	1,92	1,88	H2310	AH2310X	KM11	0,36	1,9	2,7	1,8
64	91	1,5	0,830	0,820	H311	AH311X	KM12	0,23	2,9	4,4	2,9
64	91	1,5	0,840	0,822	H311	AH311X	KM12	0,23	2,9	4,4	2,9
65	110	2	1,65	1,63	H311	AH311X	KM12	0,24	2,8	4,2	2,8
65	110	2	2,36	2,31	H2311	AH2311X	KM12	0,35	1,9	2,8	1,9
65	110	2	2,44	2,39	H2311	AH2311X	KM12	0,35	1,9	2,8	1,9
69	101	1,5	1,14	1,12	H312	AH312X	KM13	0,24	2,8	4,2	2,8
69	101	1,5	1,15	1,12	H312	AH312X	KM13	0,24	2,8	4,2	2,8
72	118	2	2,01	1,98	H312	AH312X	KM13	0,22	3,0	4,6	2,8
72	118	2	2,91	2,84	H2312	AH2312X	KM13	0,35	1,9	2,9	1,9
72	118	2	2,95	2,88	H2312	AH2312X	KM13	0,35	1,9	2,9	1,9
72	118	2	3,03	2,97	H2312	AH2312X	KM13	0,35	1,9	2,9	1,9

Double row spherical roller bearings

d = 65 to 85 mm

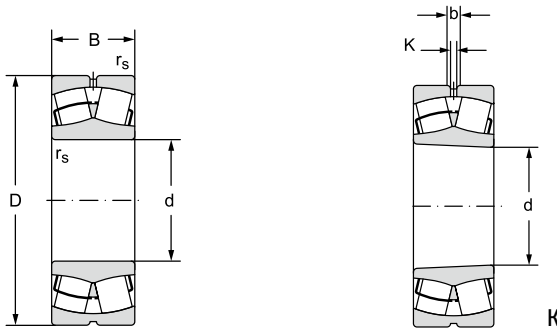

12.5.1

Main dimensions						Basic load rating		Fatigue load limit	Limiting speed for lubrication with		Bearing designation	
d	D	B	r _s	a	b	dynamic C _r	static C _{st}	P _u	grease	oil	with cylindrical bore	with tapered bore
mm						kN		kN	min ⁻¹			
65	120	31	1,5	3	5,5	200	224	27	3800	4800	22213EW33J**	22213EKW33J**
	120	31	1,5	3	5,5	200	224	27	3800	4800	22213EW33MH**	22213EKW33MH**
	140	33	2,1	3	5,5	217	250	30	2800	3600	21313CW33J**	21313CKW33J**
	140	48	2,1	3	5,5	329	351	43	2600	3400	22313EW33J**	22313EKW33J**
	140	48	2,1	3	5,5	329	351	43	2600	3400	22313EW33MH**	22313EKW33MH**
	140	48	2,1	3	5,5	329	351	43	2600	3400	22313EMHD2**	22313EKMHD2**
70	125	31	1,5	3	5,5	208	239	29	3600	4500	22214EW33J**	22214EKW33J**
	125	31	1,5	3	5,5	208	239	29	3600	4500	22214EW33MH**	22214EKW33MH**
	150	35	2,1	3	5,5	246	284	34	2600	3400	21314CW33J**	21314CKW33J**
	150	51	2,1	3	5,5	376	402	48	2400	3100	22314EW33J**	22314EKW33J**
	150	51	2,1	3	5,5	376	402	48	2400	3100	22314EW33MH**	22314EKW33MH**
	150	51	2,1	3	5,5	376	402	48	2400	3100	22314EMHD2**	22314EKMHD2**
75	130	31	1,5	3	5,5	216	255	31	3400	4300	22215EW33J**	22215EKW33J**
	130	31	1,5	3	5,5	216	255	31	3400	4300	22215EW33MH**	22215EKW33MH**
	160	37	2,1	3	5,5	266	308	36	2400	3200	21315CW33J**	21315CKW33J**
	160	55	2,1	4,5	8,3	436	489	57	2300	3000	22315EW33J**	22315EKW33J**
	160	55	2,1	4,5	8,3	436	489	57	2300	3000	22315EW33MH**	22315EKW33MH**
	160	55	2,1	4,5	8,3	436	489	57	2300	3000	22315EMHD2**	22315EKMHD2**
80	140	33	2	3	5,5	246	295	35	3200	4000	22216EW33J**	22216EKW33J**
	140	33	2	3	5,5	246	295	35	3200	4000	22216EW33MH**	22216EKW33MH**
	170	39	2,1	3	5,5	299	349	40	2200	3000	21316CW33J**	21316CKW33J**
	170	58	2,1	4,5	8,3	487	551	63	2200	2800	22316EW33J**	22316EKW33J**
	170	58	2,1	4,5	8,3	487	551	63	2200	2800	22316EW33MH**	22316EKW33MH**
	170	58	2,1	4,5	8,3	487	551	63	2200	2800	22316EMHD2**	22316EKMHD2**
85	150	36	2	3	5,5	286	337	39	3000	3800	22217EW33J**	22217EKW33J**
	150	36	2	3	5,5	286	337	39	3000	3800	22217EW33MH**	22217EKW33MH**
	180	41	3	3	5,5	327	382	43	2000	2800	21317CW33J**	21317CKW33J**
	180	60	3	4,5	8,3	530	603	68	2000	2600	22317EW33J**	22317EKW33J**
	180	60	3	4,5	8,3	530	603	68	2000	2600	22317EW33MH**	22317EKW33MH**
	180	60	3	4,5	8,3	530	603	68	2000	2600	22317EMHD2**	22317EKMHD2**

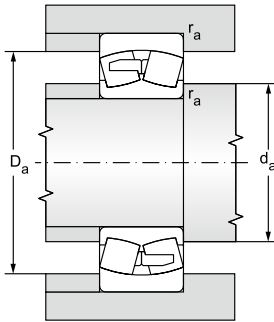

Abutment and fillet dimensions			Weight		Corresp. adapter sleeve	Corresp. withdrawal sleeve	Corresp. nut	Factors			
d _a	D _a	r _a	K					e	Y ₁	Y ₂	Y ₀
min	max	max									
mm			kg								
74	111	1,5	1,51	1,48	H313	AH313	KM15	0,24	2,9	4,2	2,8
74	111	1,5	1,53	1,50	H313	AH313	KM15	0,24	2,9	4,2	2,8
77	128	2	2,55	2,52	H313	AH313	KM15	0,23	2,9	4,3	2,8
77	128	2	3,46	3,38	H2313	AH2313	KM15	0,34	2	3	2
77	128	2	3,54	3,46	H2313	AH2313	KM15	0,34	2	3	2
77	128	2	3,64	3,56	H2313	AH2313	KM15	0,34	2	3	2
79	116	1,5	1,61	1,57	H314	AH314	KM16	0,23	2,9	4,2	2,8
79	116	1,5	1,62	1,58	H314	AH314	KM16	0,23	2,9	4,2	2,8
82	138	2	3,11	3,07	H314	AH314	KM16	0,23	2,9	4,3	2,9
82	138	2	4,19	4,10	H2314	AH2314X	KM16	0,34	2	3	2
82	138	2	4,38	4,29	H2314	AH2314X	KM16	0,34	2	3	2
82	138	2	4,40	4,31	H2314	AH2314X	KM16	0,34	2	3	2
84	121	1,5	1,70	1,66	H315	AH315	KM17	0,22	3,1	4,5	2,9
84	121	1,5	1,71	1,67	H315	AH315	KM17	0,22	3,1	4,5	2,9
87	148	2	3,74	3,69	H315	AH315	KM17	0,23	2,9	4,4	2,9
87	148	2	5,27	5,15	H2315	AH2315X	KM17	0,33	2	3	2
87	148	2	5,30	5,19	H2315	AH2315X	KM17	0,33	2	3	2
87	148	2	5,47	5,35	H2315	AH2315X	KM17	0,33	2	3	2
90	130	2	2,11	2,07	H316	AH316	KM18	0,22	3,1	4,5	3
90	130	2	2,13	2,09	H316	AH316	KM18	0,22	3,1	4,5	3
92	158	2	4,46	4,40	H316	AH316	KM18	0,23	3	4,4	2,9
92	158	2	6,25	6,11	H2316	AH2316X	KM18	0,33	2	3	2
92	158	2	6,34	6,20	H2316	AH2316X	KM18	0,33	2	3	2
92	158	2	6,51	6,37	H2316	AH2316X	KM18	0,33	2	3	2
95	140	2	2,66	2,61	H317	AH317X	KM19	0,22	3	4,4	2,9
95	140	2	2,67	2,62	H317	AH317X	KM19	0,22	3	4,4	2,9
99	166	2,5	5,31	5,24	H317	AH317X	KM19	0,24	2,8	4,2	2,8
99	166	2,5	7,16	7,01	H2317	AH2317X	KM19	0,32	2,1	3,1	2
99	166	2,5	7,30	7,15	H2317	AH2317X	KM19	0,32	2,1	3,1	2
99	166	2,5	7,48	7,34	H2317	AH2317X	KM19	0,32	2,1	3,1	2

Double row spherical roller bearings

d = 90 to 110 mm

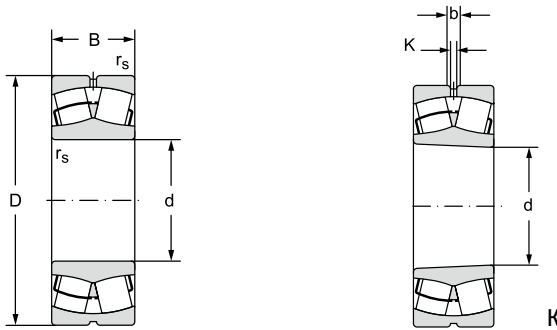

12.5.1

Main dimensions						Basic load rating		Fatigue load limit	Limiting speed for lubrication with		Bearing designation	
d	D	B	r _s	a	b	dynamic C _r	static C _{0r}	P _u	grease	oil	with cylindrical bore	with tapered bore
mm						kN		kN	min ⁻¹			
90	160	40	2	4,5	8,3	339	406	46	2600	3400	22218EW33J**	22218EKW33J**
	160	40	2	4,5	8,3	339	406	46	2600	3400	22218EW33MH**	22218EKW33MH**
	160	52,4	2	3	5,5	407	522	60	1900	2600	23218CW33J**	23218CKW33J**
	160	52,4	2	3	5,5	407	522	60	1900	2600	23218EW33MH**	23218EKW33MH**
	190	43	3	4,5	8,3	361	425	47	1900	2600	21318CW33J**	21318CKW33J**
	190	64	3	4,5	8,3	590	673	74	1900	2400	22318EW33J**	22318EKW33J**
	190	64	3	4,5	8,3	590	673	74	1900	2400	22318EW33MH**	22318EKW33MH**
	190	64	3	4,5	8,3	590	673	74	1900	2400	22318EMHD2**	22318EKMHD2**
95	170	43	2,1	4,5	8,3	381	464	52	2400	3200	22219EW33J**	22219EKW33J**
	170	43	2,1	4,5	8,3	381	464	52	2400	3200	22219EW33MH**	22219EKW33MH**
	200	45	3	4,5	8,3	398	473	51	1800	2400	21319CW33J**	21319CKW33J**
	200	67	3	4,5	8,3	665	744	81	1800	2300	22319EW33J**	22319EKW33J**
	200	67	3	4,5	8,3	665	744	81	1800	2300	22319EW33MH**	22319EKW33MH**
	200	67	3	4,5	8,3	665	744	81	1800	2300	22319EMHD2**	22319EKMHD2**
100	150	50	1,5	3	5,5	327	528	60	1800	2400	24020CW33J**	24020CK30W33J**
	165	52	2	3	5,5	410	587	66	2000	2800	23120CW33J**	23120CKW33J**
	165	52	2	3	5,5	410	587	66	2000	2800	23120EW33MH**	23120EKW33MH**
	180	46	2,1	4,5	8,3	417	510	56	2200	3000	22220EW33J**	22220EKW33J**
	180	46	2,1	4,5	8,3	417	510	56	2200	3000	22220EW33MH**	22220EKW33MH**
	180	60,3	2,1	4,5	8,3	512	667	74	1700	2200	23220CW33J**	23220CKW33J**
	180	60,3	2,1	4,5	8,3	512	667	74	1700	2200	23220EW33MH**	23220EKW33MH**
	215	47	3	4,5	8,3	439	522	56	1700	2200	21320CW33J**	21320CKW33J**
	215	73	3	4,5	8,3	750	842	90	1700	2200	22320EW33J**	22320EKW33J**
	215	73	3	4,5	8,3	750	842	90	1700	2200	22320EW33MH**	22320EKW33MH**
	215	73	3	4,5	8,3	750	842	90	1700	2200	22320EMHD2**	22320EKMHD2**

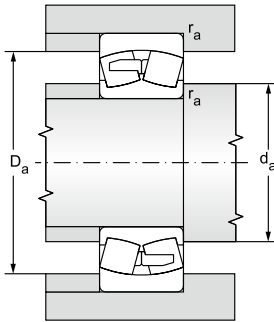

Abutment and fillet dimensions			Weight		Corresp. adapter sleeve	Corresp. withdrawal sleeve	Corresp. nut	Factors			
d _a	D _a	r _a	K					e	Y ₁	Y ₂	Y ₀
min	max	max									
mm			kg								
100	150	2	3,40	3,33	H318	AH318X	KM20	0,23	2,9	4,2	2,8
100	150	2	3,42	3,35	H318	AH318X	KM20	0,23	2,9	4,2	2,8
100	150	2	4,52	4,40	H2318	AH3218X	KM20	0,31	2,2	3,3	2,2
100	150	2	4,61	4,49	H2318	AH3218X	KM20	0,31	2,2	3,3	2,2
104	176	2,5	6,00	5,92	H318	AH318X	KM20	0,23	3	4,5	2,9
104	176	2,5	8,54	8,35	H2318	AH2318X	KM20	0,33	2,1	3,1	2
104	176	2,5	8,68	8,49	H2318	AH2318X	KM20	0,33	2,1	3,1	2
104	176	2,5	8,89	8,70	H2318	AH2318X	KM20	0,33	2,1	3,1	2
107	158	2	4,17	4,08	H319	AH319X	KM21	0,23	2,9	4,2	2,7
107	158	2	4,20	4,11	H319	AH319X	KM21	0,23	2,9	4,2	2,7
109	186	2,5	6,99	6,90	H319	AH319X	KM21	0,22	3	4,5	3
109	186	2,5	9,86	9,64	H2319	AH2319X	KM21	0,33	2,1	3,1	2
109	186	2,5	10,00	9,81	H2319	AH2319X	KM21	0,33	2,1	3,1	2
109	186	2,5	10,30	10,00	H2319	AH2319X	KM21	0,33	2,1	3,1	2
109	141	1,5	3,15	3,10	-	-	-	0,3	2,3	3,4	2,3
110	155	2	4,40	4,26	H3120	AH3120X	KM22	0,29	2,4	3,5	2,3
110	155	2	4,45	4,31	H3120	AH3120X	KM22	0,29	2,4	3,5	2,3
112	168	2	5,01	4,90	H320	AH320X	KM22	0,24	2,9	4,1	2,7
112	168	2	5,03	4,92	H320	AH320X	KM22	0,24	2,9	4,1	2,7
112	168	2	6,55	6,37	H2320	AH2320X	KM22	0,31	2,2	3,2	2,1
112	168	2	6,59	6,40	H2320	AH2320X	KM22	0,31	2,2	3,2	2,1
114	201	2,5	8,57	8,46	H320	AH320X	KM22	0,22	3,1	4,6	3
114	201	2,5	12,3	12,1	H2320	AH2320X	KM22	0,33	2	3	2
114	201	2,5	12,5	12,3	H2320	AH2320X	KM22	0,33	2	3	2
114	201	2,5	12,8	12,6	H2320	AH2320X	KM22	0,33	2	3	2

Double row spherical roller bearings

d = 120 to 140 mm

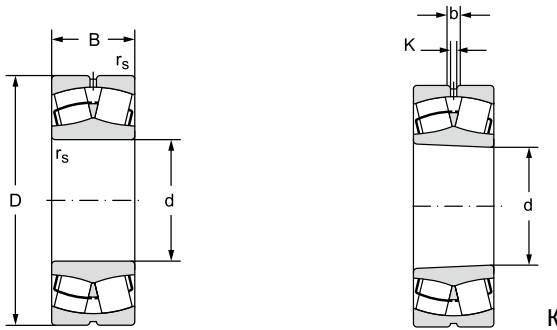

12.5.1

Main dimensions						Basic load rating		Fatigue load limit	Limiting speed for lubrication with		Bearing designation	
d	D	B	r _s	a	b	dynamic C _r	static C _{st}	P _u	grease	oil	with cylindrical bore	with tapered bore
mm						kN		kN	min ⁻¹			
110	170	45	2	3	5,5	362	516	57	2200	3000	23022CW33J**	23022CKW33J**
	170	45	2	3	5,5	362	516	57	2200	3000	23022EW33MH**	23022EKW33MH**
	170	60	2	3	5,5	442	717	79	1700	2200	24022CW33J**	24022CK30W33J**
	170	60	2	3	5,5	442	717	79	1700	2200	24022EW33MH**	24022EK30W33MH**
	180	56	2	4,5	8,3	410	585	64	1900	2600	23122CW33J**	23122CKW33J**
	180	56	2	4,5	8,3	410	585	64	1900	2600	23122EW33MH**	23122EKW33MH**
	180	69	2	3	5,5	550	849	93	1600	2000	24122CW33J**	24122CK30W33J**
	180	69	2	3	5,5	550	849	93	1600	2000	24122EW33MH**	24122EK30W33MH**
	200	53,0	2,1	4,5	8,3	537	653	70	2000	2800	22222EW33J**	22222EKW33J**
	200	53,0	2,1	4,5	8,3	537	653	70	2000	2800	22222EW33MH**	22222EKW33MH**
	200	69,8	2,1	4,5	8,3	645	867	93	1600	2000	23222CW33J**	23222CKW33J**
	200	69,8	2,1	4,5	8,3	645	867	93	1600	2000	23222EW33MH**	23222EKW33MH**
	240	80	3	6	11,1	868	1000	103	1500	1900	22322EW33J**	22322EKW33J**
	240	80,0	3	6	11,1	868	1000	103	1500	1900	22322EW33MH**	22322EKW33MH**
	240	80,0	3	6	11,1	868	1000	103	1500	1900	22322EMHD2**	22322EKMHHD2**
	240	92,1	3	6	11,1	900	1160	120	1400	1800	23322EMHD2**	-
120	180	46	2	3	5,5	380	572	62	2000	2800	23024CW33J**	23024CKW33J**
	180	46	2	3	5,5	380	572	62	2000	2800	23024EW33MH**	23024EKW33MH**
	180	60	2	3	5,5	454	770	83	1600	2000	24024CW33J**	24024CK30W33J**
	180	60	2	3	5,5	454	770	83	1600	2000	24024EW33MH**	24024EK30W33MH**
	200	62	2	4,5	8,3	575	798	85	1800	2400	23124CW33J**	23124CKW33J**
	200	62	2	4,5	8,3	575	798	85	1800	2400	23124EW33MH**	23124EKW33MH**
	200	80	2	3	5,5	702	1080	114	1400	1800	24124CW33J**	24124CK30W33J**
	200	80	2	3	5,5	702	1080	114	1400	1800	24124EW33MH**	24124EK30W33MH**
	215	58	2,1	4,5	8,3	608	775	81	1900	2600	22224EW33J**	22224EKW33J**
	215	58	2,1	4,5	8,3	608	775	81	1900	2600	22224EW33MH**	22224EKW33MH**
	215	76	2,1	4,5	8,3	746	1020	107	1500	1900	23224CW33J**	23224CKW33J**
	215	76	2,1	4,5	8,3	746	1020	107	1500	1900	23224EW33MH**	23224EKW33MH**
	260	86	3	6	11,1	1020	1180	119	1400	1800	22324EW33J**	22324EKW33J**
	260	86	3	6	11,1	1020	1180	119	1400	1800	22324EW33MH**	22324EKW33MH**
	260	86	3	6	11,1	1020	1180	119	1400	1800	22324EMHD2**	22324EKMHHD2**

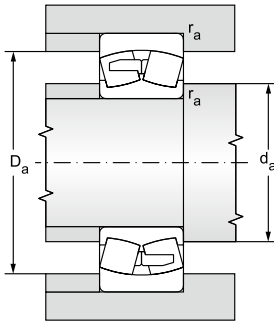

Abutment and fillet dimensions			Weight		Corresp. adapter sleeve	Corresp. withdrawal sleeve	Corresp. nut	Factors			
d _a	D _a	r _a	K					e	Y ₁	Y ₂	Y ₀
min	max	max									
mm			kg								
120	160	2	3,68	3,56	H322	AH322X	KM24	0,24	2,9	4,3	2,8
120	160	2	3,73	3,61	H322	AH322X	KM24	0,24	2,9	4,3	2,8
120	160	2	5,04	4,95	-	-	-	0,32	2,1	3,2	2,1
120	160	2	5,08	5,00	-	-	-	0,32	2,1	3,2	2,1
120	170	2	5,36	5,19	H3122	AH3122X	KM24	0,3	2,3	3,4	2,2
120	170	2	5,45	5,28	H3122	AH3122X	KM24	0,3	2,3	3,4	2,2
120	170	2	6,94	6,83	-	AH24122	KM23	0,35	1,9	2,8	1,9
120	170	2	7,04	6,93	-	AH24122	KM23	0,35	1,9	2,8	1,9
122	188	2	7,09	6,94	H322	AH3122X	KM24	0,25	2,7	4	2,6
122	188	2	7,16	7,01	H322	AH3122X	KM24	0,25	2,7	4	2,6
122	188	2	9,7	9,4	H2322	AH3222X	KM25	0,33	2,1	3,1	2
122	188	2	9,7	9,4	H2322	AH3222X	KM25	0,33	2,1	3,1	2
124	226	2,5	17,2	16,8	H2322	AH2322X	KM25	0,33	2,1	3,1	2
124	226	2,5	17,5	17,1	H2322	AH2322X	KM25	0,33	2,1	3,1	2
124	226	2,5	17,9	17,5	H2322	AH2322X	KM25	0,33	2,1	3,1	2
124	226	2,5	20,50	-	-	-	-	0,38	1,8	2,6	1,7
130	170	2	4,04	3,91	H3024	AH3024X	KM26	0,23	3	4,5	2,9
130	170	2	4,09	3,96	H3024	AH3024X	KM26	0,23	3	4,5	2,9
130	170	2	5,35	5,26	-	AH24024	KM25	0,3	2,3	3,4	2,2
130	170	2	5,42	5,34	-	AH24024	KM25	0,3	2,3	3,4	2,2
130	190	2	7,69	7,45	H3124	AH3124X	KM26	0,28	2,4	3,5	2,3
130	190	2	7,73	7,49	H3124	AH3124X	KM26	0,28	2,4	3,5	2,3
130	190	2	10,1	9,9	-	AH24124	KM26	0,37	1,8	2,7	1,8
130	190	2	10,3	10,1	-	AH24124	KM26	0,37	1,8	2,7	1,8
132	203	2	9,0	8,8	H3124	AH3124X	KM26	0,25	2,7	3,9	2,5
132	203	2	9,1	8,9	H3124	AH3124X	KM26	0,25	2,7	3,9	2,5
132	203	2	11,8	11,5	H2324	AH3224X	KM27	0,33	2	3	2
132	203	2	12,1	11,8	H2324	AH3224X	KM27	0,33	2	3	2
134	246	2,5	21,50	21,10	H2324	AH2324X	KM27	0,33	2,1	3,1	2
134	246	2,5	22,00	21,60	H2324	AH2324X	KM27	0,33	2,1	3,1	2
134	246	2,5	22,30	21,80	H2324	AH2324X	KM27	0,33	2,1	3,1	2

Double row spherical roller bearings

d = 150 to 170 mm

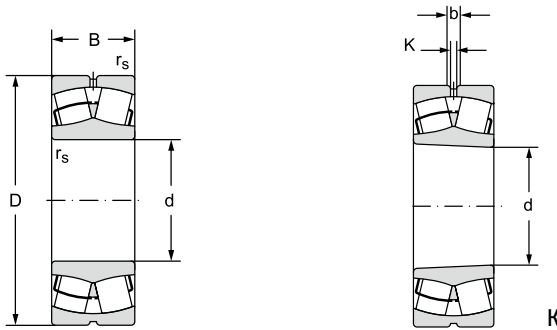

12.5.1

Main dimensions						Basic load rating		Fatigue load limit	Limiting speed for lubrication with		Bearing designation	
d	D	B	r _s	a	b	dynamic C _r	static C _{0r}	P _u	grease	oil	with cylindrical bore	with tapered bore
mm						kN		kN	min ⁻¹			
130	200	52	2	4,5	8,3	488	711	75	1900	2600	23026CW33J**	23026CKW33J**
	200	52	2	4,5	8,3	488	711	75	1900	2600	23026EW33MH**	23026EKW33MH**
	200	69	2	4,5	8,3	592	978	103	1500	1900	24026CW33J**	24026CK30W33J**
	210	64	2	4,5	8,3	620	913	95	1700	2200	23126CW33J**	23126CKW33J**
	210	64	2	4,5	8,3	620	913	95	1700	2200	23126EW33MH**	23126EKW33MH**
	210	80	2	3	5,5	722	1160	121	1300	1700	24126CW33J**	24126CK30W33J**
	210	80	2	3	5,5	722	1160	121	1300	1700	24126EW33MH**	24126EK30W33MH**
	230	64	3	6	11,1	708	948	97	1800	2400	22226EW33J**	22226EKW33J**
	230	64	3	6	11,1	708	948	97	1800	2400	22226EW33MH**	22226EKW33MH**
	230	80	3	4,5	8,3	828	1180	121	1300	1700	23226CW33J**	23226CKW33J**
	230	80	3	4,5	8,3	828	1180	121	1300	1700	23226EW33MH**	23226EKW33MH**
	280	93	4	7,5	13,9	1180	1380	136	1300	1700	22326EW33J**	22326EKW33J**
	280	93	4	7,5	13,9	1180	1380	136	1300	1700	22326EW33MH**	22326EKW33MH**
	280	93	4	7,5	13,9	1180	1380	136	1300	1700	22326EMHD2**	22326EKMHD2**
140	210	53	2	4,5	8,3	511	781	81	1800	2400	23028CW33J**	23028CKW33J**
	210	53	2	4,5	8,3	511	781	81	1800	2400	23028EW33MH**	23028EKW33MH**
	210	69	2	4,5	8,3	603	1040	107	1400	1800	24028CW33J**	24028CK30W33J**
	210	69	2	4,5	8,3	603	1040	107	1400	1800	24028EW33MH**	24028EK30W33MH**
	225	68	2,1	4,5	8,3	690	1030	105	1600	2000	23128CW33J**	23128CKW33J**
	225	85	2,1	4,5	8,3	814	1330	135	1100	1500	24128CW33J**	24128CK30W33J**
	250	68	3	6	11,1	822	1080	108	1700	2200	22228EW33J**	22228EKW33J**
	250	68	3	6	11,1	822	1080	108	1700	2200	22228EW33MH**	22228EKW33MH**
	250	88	3	6	11,1	985	1370	137	1200	1600	23228CW33J**	23228CKW33J**
	250	88	3	6	11,1	985	1370	137	1200	1600	23228EW33MH**	23228EKW33MH**
	300	102	4	7,5	13,9	1320	1560	150	1200	1500	22328CW33J**	22328CKW33J**
	300	102	4	7,5	13,9	1320	1560	150	1200	1500	22328EW33MH**	22328EKW33MH**
	300	102	4	7,5	13,9	1320	1560	150	1200	1500	22328EMHD2**	22328EKMHD2**

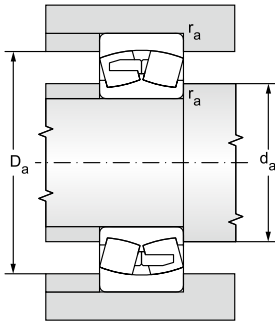

Abutment and fillet dimensions			Weight		Corresp. adapter sleeve	Corresp. withdrawal sleeve	Corresp. nut	Factors			
d _a	D _a	r _a	~ K					e	Y ₁	Y ₂	Y ₀
min	max	max									
mm			kg								
140	190	2	5,85	5,67	H3026	AH3026X	KM28	0,23	2,9	4,3	2,9
140	190	2	5,8	5,7	H3026	AH3026X	KM28	0,23	2,9	4,3	2,9
140	190	2	7,9	7,8	-	AH24026	KM27	0,31	2,2	3,2	2,1
140	200	2	8,5	8,2	H3126	AH3126X	KM28	0,28	2,4	3,6	2,4
140	200	2	8,6	8,4	H3126	AH3126X	KM28	0,28	2,4	3,6	2,4
140	200	2	10,9	10,7	-	AH24126	KM28	0,35	1,9	2,9	1,9
140	200	2	11,0	10,8	-	AH24126	KM28	0,35	1,9	2,9	1,9
144	216	2,5	11,2	11,0	H3126	AH3126X	KM28	0,26	2,6	3,8	2,5
144	216	2,5	11,6	11,3	H3126	AH3126X	KM28	0,26	2,6	3,8	2,5
144	216	2,5	13,9	13,5	H2326	AH3226X	KM29	0,33	2,1	3,1	2
144	216	2,5	14,20	13,70	H2326	AH3226X	KM29	0,33	2,1	3,1	2
148	262	3	26,80	26,20	H2326	AH2326X	KM29	0,33	2,1	3,1	2
148	262	3	27,40	26,80	H2326	AH2326X	KM29	0,33	2,1	3,1	2
148	262	3	28,0	27,4	H2326	AH2326X	KM29	0,33	2,1	3,1	2
150	200	2	6,4	6,2	H3028	AH3028X	KM30	0,22	3	4,5	3
150	200	2	6,6	6,4	H3028	AH3028X	KM30	0,22	3	4,5	3
150	200	2	8,5	8,4	-	AH24028	KM29	0,29	2,3	3,4	2,3
150	200	2	8,5	8,4	-	AH24028	KM29	0,29	2,3	3,4	2,3
152	213	2	10,3	10,0	H3128	AH3128X	KM30	0,27	2,5	3,7	2,4
152	213	2	13,1	12,9	-	AH24128	KM30	0,35	1,9	2,9	1,9
154	236	2,5	14,1	13,8	H3128	AH3128X	KM30	0,25	2,7	3,9	2,5
154	236	2,5	14,3	14,0	H3128	AH3128X	KM30	0,25	2,7	3,9	2,5
154	236	2,5	18,40	17,80	H2328	AH3228X	KM31	0,33	2	3	2
154	236	2,5	18,40	17,80	H2328	AH3228X	KM31	0,33	2,1	3,1	2
158	282	3	33,3	32,6	H2328	AH2328X	KM31	0,34	2	3	2
158	282	3	33,6	32,9	H2328	AH2328X	KM31	0,34	2	3	2
158	282	3	34,9	34,2	H2328	AH2328X	KM31	0,34	2	3	2

Double row spherical roller bearings

d = 180 to 200 mm

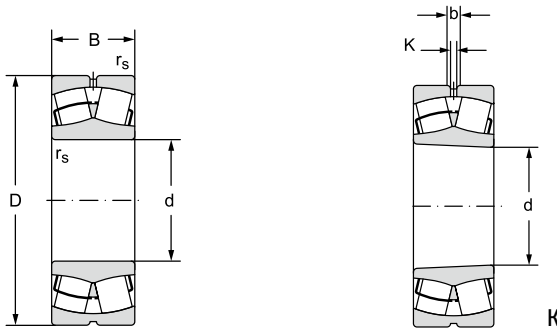

12.5.1

Main dimensions						Basic load rating		Fatigue load limit	Limiting speed for lubrication with		Bearing designation	
d	D	B	r _s	a	b	dynamic C _r	static C _{st}	P _u	grease	oil	with cylindrical bore	with tapered bore
mm						kN	kN	kN	min ⁻¹			
150	225	56	2,1	4,5	8,3	517	881	89	1700	2200	23030CW33J**	23030CKW33J**
	225	56	2,1	4,5	8,3	573	881	89	1700	2200	23030EW33MH**	23030EKW33MH**
	225	75	2,1	4,5	8,3	698	1220	123	1300	1700	24030CW33J**	24030CK30W33J**
	225	75	2,1	4,5	8,3	698	1220	123	1300	1700	24030EW33MH**	24030EK30W33MH**
	250	80	2,1	6	11,1	905	1310	130	1400	1800	23130CW33J**	23130CKW33J**
	250	100	2,1	4,5	8,3	1060	1690	167	1000	1400	24130CW33J**	24130CK30W33J**
	250	100	2,1	4,5	8,3	1060	1690	167	1000	1400	24130EW33MH**	24130EK30W33MH**
	270	73	3	7,5	13,9	949	1260	123	1600	2000	22230EW33J**	22230EKW33J**
	270	73	3	7,5	13,9	949	1260	123	1600	2000	22230EW33MH**	22230EKW33MH**
	270	96	3	6	11,1	1140	1620	158	1100	1500	23230CW33J**	23230CKW33J**
160	240	60	2,1	6	11,1	646	1010	100	1700	2200	23032CW33J**	23032CKW33J**
	240	60	2,1	6	11,1	646	1010	100	1700	2200	23032EW33MH**	23032EKW33MH**
	240	80	2,1	4,5	8,3	790	1400	139	1100	1500	24032CW33J**	24032CK30W33J**
	270	86	2,1	6	11,1	1040	1480	143	1300	1700	23132CW33J**	23132CKW33J**
	270	109	2,1	4,5	8,3	1120	1980	192	950	1300	24132CW33J**	24132CK30W33J**
	290	80	3	7,5	13,9	1080	1440	138	1500	1900	22232EW33J**	22232EKW33J**
	290	80	3	7,5	13,9	1080	1440	138	1500	1900	22232EW33MH**	22232EKW33MH**
	290	104	3	7,5	13,9	1260	1840	176	1000	1400	23232CW33J**	23232CKW33J**
	290	104	3	7,5	13,9	1260	1840	176	1000	1400	23232EW33MH**	23232EKW33MH**
	340	114	4	9	16,7	1690	2090	194	1000	1300	22332CW33J**	22332CKW33J**
170	260	67	2,1	6	11,1	770	1190	97	1600	2000	23034CW33J**	23034CKW33J**
	260	67	2,1	6	11,1	770	1190	97	1600	2000	23034EW33MH**	23034EKW33MH**
	260	90	2,1	4,5	8,3	962	1660	136	1000	1400	24034CW33J**	24034CK30W33J**
	280	88	2,1	6	11,1	1070	1620	131	1200	1600	23134CW33J**	23134CKW33J**
	280	109	2,1	4,5	8,3	1260	2090	169	900	1200	24134CW33J**	24134CK30W33J**
	310	86	4	7,5	13,9	1190	1600	128	1300	1700	22234CW33J**	22234CKW33J**
	310	86	4	7,5	13,9	1190	1600	128	1300	1700	22234EW33MH**	22234EKW33MH**
	310	110	4	7,5	13,9	1470	2040	163	950	1300	23234CW33J**	23234CKW33J**
	310	110	4	7,5	13,9	1470	2040	163	950	1300	23234EW33MH**	23234EKW33MH**
	360	120	4	9	16,7	1780	2280	179	950	1250	22334CW33J**	22334CKW33J**
180	260	67	2,1	6	11,1	770	1190	97	1600	2000	23034CW33J**	23034CKW33J**
	260	67	2,1	6	11,1	770	1190	97	1600	2000	23034EW33MH**	23034EKW33MH**
	260	90	2,1	4,5	8,3	962	1660	136	1000	1400	24034CW33J**	24034CK30W33J**
	280	88	2,1	6	11,1	1070	1620	131	1200	1600	23134CW33J**	23134CKW33J**
190	280	109	2,1	4,5	8,3	1260	2090	169	900	1200	24134CW33J**	24134CK30W33J**
	310	86	4	7,5	13,9	1190	1600	128	1300	1700	22234CW33J**	22234CKW33J**
	310	86	4	7,5	13,9	1190	1600	128	1300	1700	22234EW33MH**	22234EKW33MH**
	310	110	4	7,5	13,9	1470	2040	163	950	1300	23234CW33J**	23234CKW33J**
200	360	120	4	9	16,7	1780	2280	179	950	1250	22334CW33J**	22334CKW33J**
	360	120	4	9	16,7	1780	2280	179	950	1250	22334EW33MH**	22334EKW33MH**
	360	120	4	9	16,7	1780	2280	179	950	1250	22334EMHD2**	22334EKMH2**
	360	120	4	9	16,7	1780	2280	179	950	1250	22334EMHD2**	22334EKMH2**

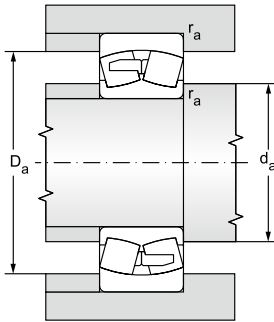

Abutment and fillet dimensions			Weight		Corresp. adapter sleeve	Corresp. withdrawal sleeve	Corresp. nut	Factors			
d _a	D _a	r _a	K					e	Y ₁	Y ₂	Y ₀
min	max	max									
mm			kg								
162	213	2	7,7	7,5	H3030	AH3030X	KM32	0,22	3,1	4,6	3
162	213	2	8,0	7,8	H3030	AH3030X	KM32	0,22	3,1	4,6	3
162	213	2	10,6	10,5	-	AH24030	KM31	0,3	2,3	3,4	2,2
162	213	2	10,6	10,5	-	AH24030	KM31	0,3	2,3	3,4	2,2
162	238	2	15,5	15,0	H3130	AH3130X	KM33	0,29	2,3	3,4	2,3
162	238	2	19,9	19,6	-	AH24130	KM32	0,37	1,8	2,7	1,8
162	238	2	20,0	19,7	-	AH24130	KM32	0,37	1,8	2,7	1,8
164	256	2,5	17,9	17,5	H3130	AH3130X	KM33	0,25	2,7	3,9	2,5
164	256	2,5	18,0	17,6	H3130	AH3130X	KM33	0,25	2,7	3,9	2,5
164	256	2,5	23,3	22,6	H2330	AH3230X	KM33	0,33	2	3	2
164	256	2,5	23,8	23,1	H2330	AH3230X	KM33	0,33	2	3	2
168	302	3	40,3	39,5	H2330	AH2330X	KM33	0,33	2	3	2
168	302	3	41,1	40,3	H2330	AH2330X	KM33	0,33	2	3	2
168	302	3	41,9	41,0	H2330	AH2330X	KM33	0,33	2	3	2
172	228	2	9,4	9,1	H3032	AH3032	KM34	0,22	3,1	4,6	3
172	228	2	9,7	9,4	H3032	AH3032	KM34	0,22	3,1	4,6	3
172	228	2	12,9	12,7	-	AH24032	KM34	0,3	2,3	3,4	2,2
172	258	2	19,4	18,8	H3132	AH3132	KM36	0,32	2,1	3	2
172	258	2	25,7	25,3	-	AH24132	KM34	0,38	1,8	2,7	1,8
174	276	2,5	22,7	22,2	H3132	AH3132	KM36	0,26	2,6	3,8	2,5
174	276	2,5	22,9	22,4	H3132	AH3132	KM36	0,26	2,6	3,9	2,6
174	276	2,5	30,3	29,4	H2332	AH3232	KM36	0,34	2	2,9	1,9
174	276	2,5	25,0	24,1	H2332	AH3232	KM36	0,34	2	2,9	1,9
178	322	3	49,5	48,5	H2332	AH2332	KM36	0,33	2	3	2
178	322	3	50,5	49,5	H2332	AH2332	KM36	0,33	2	3	2
178	322	3	49,8	48,8	H2332	AH2332	KM36	0,33	2	3	2
182	248	2	12,6	12,2	H3034	AH3034	KM36	0,23	2,9	4,4	2,9
182	248	2	12,7	12,3	H3034	AH3034	KM36	0,23	2,9	4,4	2,9
182	248	2	17,3	17,1	-	AH24034	KM36	0,31	2,2	3,2	2,1
182	268	2	21,0	20,4	H3134	AH3134	KM38	0,29	2,4	3,5	2,3
182	268	2	27,0	26,6	-	AH24134	KM36	0,36	1,9	2,8	1,8
188	292	3	27,6	27,0	H3134	AH3134	KM38	0,26	2,6	3,9	2,6
188	292	3	28,0	27,4	H3134	AH3134	KM38	0,26	2,6	3,9	2,6
188	292	3	35,3	34,3	H2334	AH3234	KM38	0,34	2	3	2
188	292	3	36,0	35,0	H2334	AH3234	KM38	0,34	2	3	2
188	342	3	56,8	55,5	H2334	AH2334	KM38	0,34	2	3	2
188	342	3	57,7	58,7	H2334	AH2334	KM38	0,34	2	3	2
188	342	3	59,1	57,8	H2334	AH2334	KM38	0,34	2	3	2

Double row spherical roller bearings

d = 220 to 260 mm

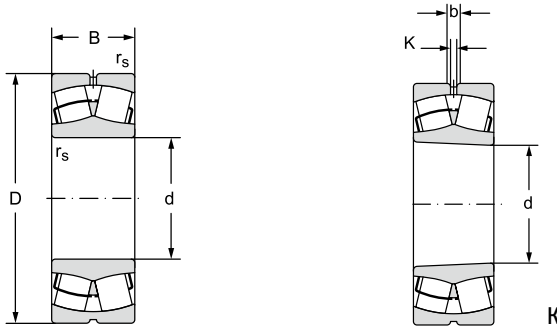

12.5.1

Main dimensions						Basic load rating		Fatigue load limit	Limiting speed for lubrication with		Bearing designation	
d	D	B	r _s	a	b	dynamic C _r	static C _{st}	P _u	grease	oil	with cylindrical bore	with tapered bore
mm						kN		kN	min ⁻¹			
180	250	52	2	3	5,5	515	919	89	1700	2200	23936CW33J**	23936CKW33J**
	250	52	2	3	5,5	515	919	89	1700	2200	23936EW33MH**	23936EKW33MH**
	280	74	2,1	7,5	13,9	920	1410	134	1400	1800	23036CW33J**	23036CKW33J**
	280	74	2,1	7,5	13,9	920	1410	134	1400	1800	23036EW33MH**	23036EKW33MH**
	280	100	2,1	4,5	8,3	1170	1980	188	950	1300	24036CW33J**	24036CK30W33J**
	280	100	2,1	4,5	8,3	1170	1980	188	950	1300	24036EW33MH**	24036EK30W33MH**
	300	96	3	7,5	13,9	1260	1890	177	1100	1500	23136CW33J**	23136CKW33J**
	300	118	3	6	11,1	1370	2400	225	850	1100	24136CW33J**	24136CK30W33J**
	320	86	4	9	16,7	1230	1700	157	1300	1700	22236CW33J**	22236CKW33J**
	320	86	4	9	16,7	1280	1700	157	1300	1700	22236EW33MH**	22236EKW33MH**
	320	112	4	7,5	13,9	1540	2210	205	900	1200	23236CW33J**	23236CKW33J**
	380	126	4	12	22,3	1950	2530	227	900	1200	22336CW33J**	22336CKW33J**
	380	126	4	12	22,3	1950	2530	227	900	1200	22336EW33MH**	22336EKW33MH**
	380	126	4	12	22,3	1950	2530	227	900	1200	22336EMHD2**	22336EKMHD2**
190	260	52	2	3	5,5	520	966	92	1700	2200	23938EW33MH**	23938EKW33MH**
	290	75	2,1	7,5	13,9	962	1510	142	1300	1700	23038CW33J**	23038CKW33J**
	290	75	2,1	7,5	13,9	962	1510	142	1300	1700	23038EW33MH**	23038EKW33MH**
	290	100	2,1	4,5	8,3	1190	2070	194	920	1250	24038CW33J**	24038CK30W33J**
	290	100	2,1	4,5	8,3	1190	2070	194	920	1250	24038EW33MH**	24038EK30W33MH**
	320	104	3	7,5	13,9	1440	2180	201	1000	1400	23138CW33J**	23138CKW33J**
	320	104	3	7,5	13,9	1440	2180	201	1000	1400	23138EW33MH**	23138EKW33MH**
	340	92	4	9	16,7	1400	1900	173	1200	1600	22238CW33J**	22238CKW33J**
	340	92	4	9	16,7	1400	1900	173	1200	1600	22238EW33MH**	22238EKW33MH**
	340	120	4	9	16,7	1730	2530	230	850	1100	23238CW33J**	23238CKW33J**
	400	132	5	12	22,3	2140	2810	248	850	1100	22338CW33J**	22338CKW33J**
	400	132	5	12	22,3	2140	2810	248	850	1100	22338EW33MH**	22338EKW33MH**
200	280	60	2,1	4,5	8,3	650	1160	109	1600	2000	23940EW33MH**	23940EKW33MH**
	310	82	2,1	7,5	13,9	1120	1730	159	1200	1600	23040CW33J**	23040CKW33J**
	310	82	2,1	7,5	13,9	1120	1730	159	1200	1600	23040EW33MH**	23040EK30W33MH**
	310	109	2,1	6	11,1	1390	2370	218	900	1200	24040CW33J**	24040CK30W33J**
	310	109	2,1	6	11,1	1390	2370	218	900	1200	24040EW33MH**	24040EK30W33MH**
	340	112	3	9	16,7	1630	2410	218	950	1300	23140CW33J**	23140CKW33J**
	340	112	3	9	16,7	1630	2410	218	950	1300	23140EW33MH**	23140EKW33MH**
	340	140	3	6	11,1	1920	3160	286	800	1000	24140EW33MH**	24140EK30W33MH**
	360	98	4	9	16,7	1560	2140	192	1100	1500	22240CW33J**	22240CKW33J**
	360	98	4	9	16,7	1560	2140	192	1100	1500	22240EW33MH**	22240EKW33MH**
	360	128	4	9	16,7	1930	2850	255	800	1000	23240CW33J**	23240CKW33J**
	420	138	5	12	22,3	2340	3110	270	800	1000	22340CW33J**	22340CKW33J**
	420	138	5	12	22,3	2340	3110	270	800	1000	22340EW33MH**	22340EKW33MH**

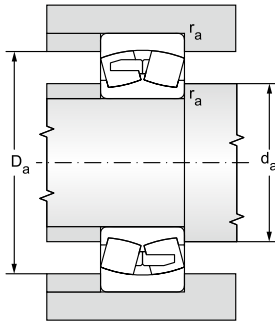

Abutment and fillet dimensions			Weight		Corresp. adapter sleeve	Corresp. withdrawal sleeve	Corresp. nut	Factors			
d _a	D _a	r _a	K					e	Y ₁	Y ₂	Y ₀
min	max	max									
mm			kg								
190	240	2	7,7	7,5	H3936	-	-	0,18	3,7	5,5	3,7
190	240	2	7,7	7,4	H3936	-	-	0,18	3,7	5,5	3,7
192	268	2	16,3	15,8	H3036	AH3036	KM38	0,24	2,9	4,2	2,8
192	268	2	16,5	16,0	H3036	AH3036	KM38	0,24	2,9	4,2	2,8
192	268	2	22,9	22,6	-	AH24036	KM38	0,32	2,1	3,1	2
192	268	2	23,2	22,9	-	AH24036	KM38	0,32	2,1	3,1	2
194	286	2,5	26,6	25,8	H3136	AH3136	KM40	0,29	2,3	3,4	2,3
194	286	2,5	32,9	32,4	-	AH24136	KM38	0,37	1,8	2,7	1,8
198	302	3	29,1	28,4	H3136	AH2236	KM40	0,25	2,7	4	2,7
198	302	3	29,2	28,6	H3136	AH2236	KM40	0,25	2,7	4	2,7
198	302	3	37,5	36,3	H2336	AH2336	KM40	0,33	2,1	3,1	2
198	362	3	65,8	64,3	H2336	AH2336	KM40	0,33	2,1	3,1	2
198	362	3	67,1	65,6	H2336	AH2336	KM40	0,33	2,1	3,1	2
198	362	3	68,3	66,8	H2336	AH2336	KM40	0,33	2,1	3,1	2
200	250	2	8,1	7,8	H3938	-	-	0,17	3,9	5,8	3,8
202	278	2	17,4	16,9	H3038	AH3038	HML41T	0,23	2,9	4,4	2,9
202	278	2	17,6	17,1	H3038	AH3038	HML41T	0,23	2,9	4,4	2,9
202	278	2	23,7	23,3	-	AH24038	KM40	0,31	2,2	3,2	2,1
202	278	2	24,0	23,6	-	AH24038	KM40	0,31	2,2	3,2	2,1
204	306	2,5	33,6	32,6	H3138	AH3138	HM42T	0,3	2,3	3,4	2,2
204	306	2,5	34,5	33,4	H3138	AH3138	HM42T	0,3	2,3	3,4	2,2
208	322	3	35,1	34,3	H3138	AH2238	HM42T	0,25	2,7	4	2,6
208	322	3	35,6	34,8	H3138	AH2238	HM42T	0,25	2,7	4	2,6
208	322	3	45,8	44,4	H2338	AH2338	HM42T	0,33	2	3	2
212	378	4	76,3	74,6	H2338	AH2338	HM42T	0,32	2,1	3,1	2
212	378	4	77,7	76,0	H2338	AH2338	HM42T	0,32	2,1	3,1	2
212	268	2	11,3	11,0	H3940	-	-	0,19	3,6	5,4	3,5
212	298	2	22,2	21,5	H3040	AH3040	HML43T	0,24	2,9	4,3	2,8
212	298	2	22,5	21,8	H3040	AH3040	HML43T	0,24	2,9	4,3	2,8
212	298	2	30,1	29,6	-	AH24040	HM42T	0,32	2,1	3,1	2,1
212	298	2	30,8	30,3	-	AH24040	HM42T	0,32	2,1	3,1	2,1
214	326	2,5	40,5	39,2	H3140	AH3140	HM44T	0,3	2,2	3,3	2,2
214	326	2,5	41,5	40,2	H3140	AH3140	HM44T	0,3	2,2	3,3	2,2
214	326	2,5	53,4	52,6	-	AH24140	HM42T	0,39	1,9	2,6	1,7
218	342	3	43,0	42,0	H3140	AH2240	HM44T	0,25	2,6	3,9	2,6
218	342	3	42,7	41,7	H3140	AH2240	HM44T	0,25	2,6	3,9	2,6
218	342	3	55,1	53,5	H2340	AH2340	HM44T	0,33	2	3	2
222	398	4	89,2	87,2	H2340	AH2340	HM44T	0,32	2,1	3,1	2
222	398	4	90,7	88,7	H2340	AH2340	HM44T	0,32	2,1	3,1	2

Double row spherical roller bearings

d = 280 to 340 mm

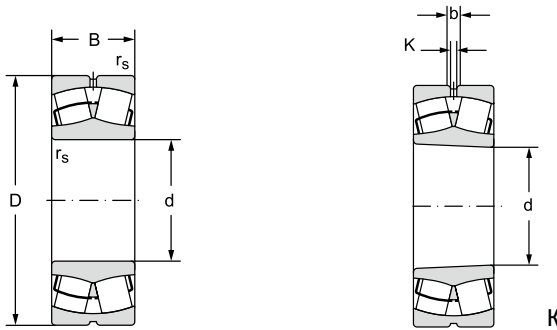

12.5.1

Main dimensions						Basic load rating		Fatigue load limit	Limiting speed for lubrication with		Bearing designation	
d	D	B	r _s	a	b	dynamic C _r	static C _{st}	P _u	grease	oil	with cylindrical bore	with tapered bore
mm						kN		kN	min ⁻¹			
220	300	60	2,1	4,5	8,3	680	1330	122	1500	1900	23944CW33J**	23944CKW33J**
	300	60	2,1	4,5	8,3	680	1330	122	1500	1900	23944EW33MH**	23944EKW33MH**
	340	90	3	7,5	13,9	1320	2090	187	1100	1500	23044CW33J**	23044CKW33J**
	340	90	3	7,5	13,9	1320	2090	187	1100	1500	23044EW33MH**	23044EKW33MH**
	340	118	3	6	11,1	1650	2830	253	850	1100	24044CW33J**	24044CK30W33J**
	340	118	3	6	11,1	1650	2830	253	850	1100	24044EW33MH**	24044EK30W33MH**
	370	120	4	9	16,7	1880	2890	255	900	1200	23144CW33J**	23144CKW33J**
	370	120	4	9	16,7	1880	2890	255	900	1200	23144EW33MH**	23144EKW33MH**
	370	150	4	6	11,1	2200	3690	325	750	950	24144EW33MH**	24144EK30W33MH**
	400	108	4	9	16,7	1900	2630	228	950	1300	22244CW33J**	22244CKW33J**
	400	108	4	9	16,7	1900	2630	228	950	1300	22244EW33MH**	22244EKW33MH**
	400	144	4	9	16,7	2400	3610	314	750	950	23244CW33J**	23244CKW33J**
	460	145	5	12	22,3	2660	3570	302	750	950	22344CW33J**	22344CKW33J**
	460	145	5	12	22,3	2660	3570	302	750	950	22344EW33MH**	22344EKW33MH**
240	320	60	2,1	4,5	8,3	695	1450	130	1300	1700	23948EW33MH**	23948EKW33MH**
	360	92	3	7,5	13,9	1390	2310	203	1000	1400	23048CW33J**	23048CKW33J**
	360	92	3	7,5	13,9	1390	2310	203	1000	1400	23048EW33MH**	23048EKW33MH**
	360	118	3	6	11,1	1690	3060	268	800	1000	24048EW33MH**	24048EK30W33MH**
	400	128	4	9	16,7	2160	3340	287	850	1100	23148CW33J**	23148CKW33J**
	400	128	4	9	16,7	2160	3340	287	850	1100	23148EW33MH**	23148EKW33MH**
	400	160	4	6	11,1	2510	4260	366	670	850	24148EW33MH**	24148EK30W33MH**
	440	120	4	12	22,3	2050	3070	259	900	1200	22248CW33J**	22248CKW33J**
	440	160	4	12	22,3	2870	4150	351	670	850	23248EW33MH**	23248EKW33MH**
	500	155	5	12	22,3	2980	4020	331	670	850	22348CW33J**	22348CKW33J**
	500	155	5	12	22,3	2980	4020	331	670	850	22348EW33MH**	22348EKW33MH**
260	360	75	2,1	4,5	8,3	970	1930	168	1100	1500	23952CW33J**	23952CKW33J**
	360	75	2,1	4,5	8,3	970	1930	168	1100	1500	23952EW33MH**	23952EKW33MH**
	400	104	4	9	16,7	1650	2790	238	900	1200	23052CW33J**	23052CKW33J**
	400	104	4	9	16,7	1650	2790	238	900	1200	23052EW33MH**	23052EKW33MH**
	400	140	4	6	11,1	2190	4020	343	700	900	24052EW33MH**	24052EK30W33MH**
	440	144	4	9	16,7	2610	4130	346	800	1000	23152CW33J**	23152CKW33J**
	440	144	4	9	16,7	2610	4130	346	800	1000	23152EW33MH**	23152EKW33MH**
	440	180	4	7,5	13,9	3100	5320	446	600	750	24152EW33MH**	24152EK30W33MH**
	480	130	5	12	22,3	2650	3600	290	850	1100	22252EW33MH**	22252EKW33MH**
	480	174	5	12	22,3	3250	4850	399	630	800	23252EW33MH**	23252EKW33MH**
	540	165	6	12	22,3	3400	4670	376	630	800	22352CW33J**	22352CKW33J**
	540	165	6	12	22,3	3400	4670	376	630	800	22352EW33MH**	22352EKW33MH**

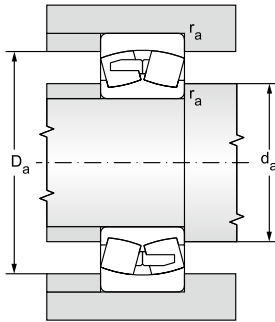

Abutment and fillet dimensions			Weight		Corresp. adapter sleeve	Corresp. withdrawal sleeve	Corresp. nut	Factors			
d _a	D _a	r _a	K					e	Y ₁	Y ₂	Y ₀
min	max	max									
mm			kg								
232	288	2	12,7	12,3	H3944	-	-	0,16	4,2	6,3	4
232	288	2	12,4	12,1	H3944	-	-	0,16	4,2	6,3	4
234	326	2,5	29,2	28,3	H3044	AH3044	HML47T	0,24	2,9	4,3	2,8
234	326	2,5	29,6	28,7	H3044	AH3044	HML47T	0,24	2,9	4,3	2,8
234	326	2,5	39	38,3	-	AOH24044	HM46T	0,32	2,3	3,1	2,1
234	326	2,5	39,7	39	-	AOH24044	HM46T	0,32	2,3	3,1	2,1
238	352	3	50,8	49,2	H3144	AH3144	HM48T	0,3	2,3	3,4	2,2
238	352	3	52,3	50,7	H3144	AH3144	HM48T	0,3	2,3	3,4	2,2
238	352	3	67,1	66,1	-	AOH24144	HM46T	0,38	1,8	2,6	1,7
238	382	3	58,8	57,5	H3144	AH2244	HM48T	0,25	2,7	4	2,6
238	382	3	58,6	57,3	H3144	AH2244	HM48T	0,25	2,7	4	2,6
238	382	3	77,9	75,5	H2344	AH2344	HM48T	0,34	2	3	2
242	438	4	111,0	109,0	H2344	AH2344	HM48T	0,31	2,2	3,2	2,1
242	438	4	112,0	110,0	H2344	AH2344	HM48T	0,31	2,2	3,2	2,1
252	308	2	13,3	13	H3948	-	-	0,15	4,5	6,7	4,5
254	346	2,5	32	31	H3048	AH3048	HM52T	0,23	3	4,5	2,9
254	346	2,5	32,4	31,4	H3048	AH3048	HM52T	0,23	3	4,5	2,9
254	346	2,5	42,8	42,1	-	AOH24048	HM50T	0,3	2,3	3,4	2,2
258	382	3	63,0	61,0	H3148	AH3148	HM52T	0,29	2,3	3,4	2,3
258	382	3	64,5	62,5	H3148	AH3148	HM52T	0,29	2,3	3,4	2,3
258	382	3	82,5	81,3	-	AOH24148	HM52T	0,38	1,8	2,7	1,8
258	422	3	80,0	78,2	H3148	AH2248	HM52T	0,26	2,6	3,9	2,6
258	422	3	107,0	104,0	H2348	AH2348	HM52T	0,35	1,9	2,9	1,8
262	478	4	140,0	137,0	H2348	AH2348	HM52T	0,3	2,2	3,3	2,2
262	478	4	142,0	139,0	H2348	AH2348	HM52T	0,3	2,2	3,3	2,2
272	348	2	23,4	22,6	H3952	-	-	0,18	3,7	5,5	3,7
272	348	2	22,9	22,2	H3952	-	-	0,18	3,7	5,5	3,7
278	382	3	45,8	44,4	H3052	AH3052	HM56T	0,23	2,9	4,3	2,9
278	382	3	46,4	44,9	H3052	AH3052	HM56T	0,23	2,9	4,3	2,9
278	382	3	65	63,9	-	AOH24052	HM56T	0,32	2,1	3,1	2,1
278	422	3	87,8	85,0	H3152	AH3152	HM58T	0,32	2	3,1	2
278	422	3	90,3	87,5	H3152	AH3152	HM58T	0,32	2	3,1	2
278	422	3	115,0	113,0	-	AOH24152	HM56T	0,39	1,8	2,6	1,7
282	458	4	108,0	106,0	H3152	AH2252	HM58T	0,29	2,3	3,4	2,2
282	458	4	138,0	133,0	H2352	AH2352	HM58T	0,37	1,8	2,6	1,7
288	512	5	173,0	170,0	H2352	AH2352	HM58T	0,3	2,3	3,4	2,2
288	512	5	175	172	H2352	AH2352	HM58T	0,3	2,3	3,4	2,2

Double row spherical roller bearings

d = 360 to 440 mm

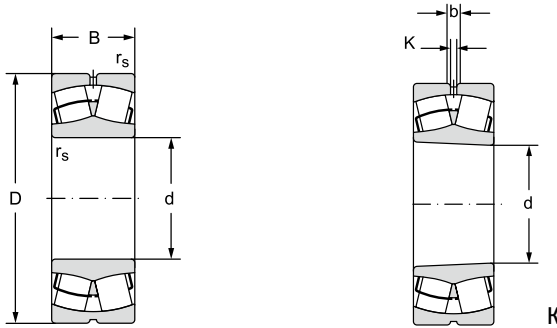

12.5.1

Main dimensions						Basic load rating		Fatigue load limit	Limiting speed for lubrication with		Bearing designation	
d	D	B	r _s	a	b	dynamic C _r	static C _{st}	P _u	grease	oil	with cylindrical bore	with tapered bore
mm						kN		kN	min ⁻¹			
280	380	75	2,1	4,5	8,3	1000	2100	179	1000	1400	23956EW33MH**	23956EKW33MH**
	420	106	4	9	16,7	1740	3060	256	850	1100	23056CW33J**	23056CKW33J**
	420	106	4	9	16,7	1740	3060	256	850	1100	23056EW33MH**	23056EKW33MH**
	420	140	4	6	11,1	2240	4280	358	670	850	24056EK30W33MH**	24056EK30W33MH**
	460	146	5	9	16,7	2650	4470	368	750	950	23156CW33J**	23156CKW33J**
	460	146	5	9	16,7	2650	4470	368	750	950	23156EW33MH**	23156EKW33MH**
	460	180	5	7,5	13,9	3220	5630	464	560	700	24156EW33MH**	24156EK30W33MH**
	500	130	5	12	22,3	2700	3950	312	800	1000	22256EW33MH**	22256EKW33MH**
	500	176	5	12	22,3	3340	5240	425	600	750	23256EW33MH**	23256EKW33MH**
	580	175	6	12	22,3	3840	5340	420	600	750	22356CW33J**	22356CKW33J**
	580	175	6	12	22,3	3840	5340	420	600	750	22356EW33MH**	22356EKW33MH**
300	420	90	3	6	11,1	1360	2690	223	950	1300	23960EW33MH**	23960EKW33MH**
	460	118	4	9	16,7	2100	3720	304	800	1000	23060CW33J**	23060CKW33J**
	460	118	4	9	16,7	2100	3720	304	800	1000	23060EW33MH**	23060EKW33MH**
	460	160	4	7,5	13,9	2670	5230	427	600	750	24060CW33J**	24060CK30W33J**
	460	160	4	7,5	13,9	2670	5230	427	600	750	24060EW33MH**	24060EK30W33MH**
	500	160	5	9	16,7	3050	5160	415	670	850	23160CW33J**	23160CKW33J**
	500	160	5	9	16,7	3050	5160	415	670	850	23160EW33MH**	23160EKW33MH**
	500	200	5	7,5	13,9	3590	6790	546	530	670	24160EW33MH**	24160EK30W33MH**
	540	140	5	12	22,3	3150	4350	345	750	950	22260EW33MH**	22260EKW33MH**
	540	192	5	12	22,3	3750	6150	488	530	670	23260EW33MH**	23260EKW33MH**
320	440	90	3	6	11,1	1380	2830	231	900	1200	23964EW33MH**	23964EKW33MH**
	480	121	4	9	16,7	2180	4090	329	750	950	23064CW33J**	23064CKW33J**
	480	121	4	9	16,7	2180	4090	329	750	950	23064EW33MH**	23064EKW33MH**
	480	160	4	7,5	13,9	2750	5500	443	560	700	24064CW33J**	24064CK30W33J**
	480	160	4	7,5	13,9	2750	5500	443	560	700	24064EW33MH**	24064EK30W33MH**
	540	176	5	12	22,3	3560	6150	484	630	800	23164CW33J**	23164CKW33J**
	540	176	5	12	22,3	3560	6150	484	630	800	23164EW33MH**	23164EKW33MH**
	540	218	5	9	16,7	4120	7870	620	480	600	24164EW33MH**	24164EK30W33MH**
	580	150	5	12	22,3	3600	5000	388	670	850	22264EW33MH**	22264EKW33MH**
	580	208	5	12	22,3	4160	7070	549	500	630	23264EW33MH**	23264EKW33MH**

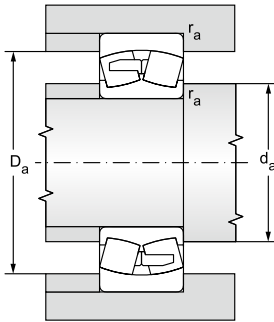

Abutment and fillet dimensions			Weight		Corresp. adapter sleeve	Corresp. withdrawal sleeve	Corresp. nut	Factors			
d _a	D _a	r _a	K					e	Y ₁	Y ₂	Y ₀
min	max	max									
mm			kg								
292	368	2	25	24,2	H3956	-	-	0,16	4,2	6,3	4
298	402	3	50	48,4	H3056	AH3056	HM3060	0,22	3	4,5	3
298	402	3	51,5	49,9	H3056	AH3056	HM3060	0,22	3	4,5	3
298	402	3	69,7	68,6	-	AOH24056	HM58T	0,3	2,2	3,3	2,2
302	438	4	93,9	90,8	H3156	AH3156	HM62T	0,29	2,3	3,5	2,3
302	438	4	96,5	93,4	H3156	AH3156	HM62T	0,29	2,3	3,5	2,3
302	438	4	121,0	119,0	-	AOH24156	HM3160	0,37	1,8	2,7	1,8
302	478	4	113,0	110,0	H3156	AH2256	HM62T	0,28	2,4	3,5	2,3
302	478	4	148,0	143,0	H2356	AH2356	HM62T	0,36	1,9	2,7	1,8
308	552	5	211	207	H2356	AH2356	HM62T	0,3	2,3	3,4	2,2
308	552	5	214	209	H2356	AH2356	HM62T	0,3	2,3	3,4	2,2
314	406	2,5	38,3	37	H3960	-	-	0,19	3,6	5,4	3,5
318	442	3	69,6	67,5	H3060	AH3060	HM3064	0,23	3	4,4	2,9
318	442	3	71,5	69,4	H3060	AH3060	HM3064	0,23	3	4,4	2,9
318	442	3	98,1	96,6	-	AOH24060	HM62T	0,32	2,1	3,2	2,1
318	442	3	97,7	96,2	-	AOH24060	HM62T	0,32	2,1	3,2	2,1
322	478	4	123	119	H3160	AH3160	HM66T	0,29	2,3	3,4	2,3
322	478	4	127	123	H3160	AH3160	HM66T	0,29	2,3	3,4	2,3
322	478	4	163	160	-	AOH24160	HM3164	0,37	1,8	2,7	1,8
322	518	4	143	140	H3160	AH2260	HM66T	0,27	2,5	3,6	2,4
422	518	4	188	183	H3260	AH3260	HM66T	0,36	1,8	2,7	1,8
334	426	2,5	40,4	39,1	H3964	-	-	0,18	3,8	5,7	3,7
338	462	3	76,1	73,7	H3064	AH3064	HML69T	0,22	3	4,5	3
338	462	3	76,8	74,4	H3064	AH3064	HML69T	0,22	3	4,5	3
338	462	3	103	101	-	AOH24064	HM66T	0,3	2,2	3,3	2,2
338	462	3	103	101	-	AOH24064	HM66T	0,3	2,2	3,3	2,2
342	518	4	160	155	H3164	AH3164	HM70T	0,3	2,2	3,3	2,2
342	518	4	162	157	H3164	AH3164	HM70T	0,3	2,2	3,3	2,2
342	518	4	208	205	-	AOH24164	HM3168	0,38	1,8	2,6	1,7
342	558	4	172	166	H3164	AH2264	HM70T	0,27	2,5	3,6	2,3
342	558	4	238	231	H3264	AH3246	HM70T	0,37	1,8	2,6	1,7

Double row spherical roller bearings

d = 460 to 600 mm

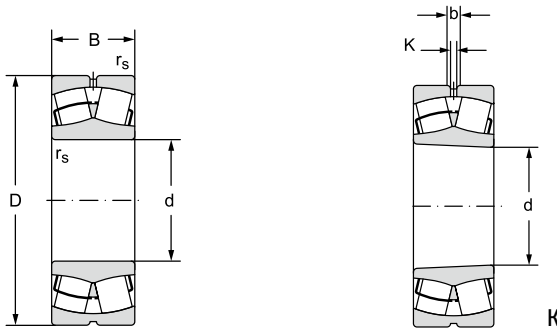

12.5.1

Main dimensions						Basic load rating		Fatigue load limit	Limiting speed for lubrication with		Bearing designation	
d	D	B	r _s	a	b	dynamic C _r	static C _{0r}	P _u	grease	oil	with cylindrical bore	with tapered bore
mm						kN		kN	min ⁻¹			
340	460	90	3	6	11,1	1410	3020	243	880	1150	23968EW33MH**	23968EKW33MH**
	520	133	5	12	22,3	2680	4750	374	700	900	23068EW33MH**	23068EKW33MH**
	520	180	5	9	16,7	3280	6710	528	530	670	24068EW33MH**	24068EK30W33MH**
	580	190	5	12	22,3	4240	7080	546	600	750	23168CW33J**	23168CKW33J**
	580	190	5	12	22,3	4240	7080	546	600	750	23168EW33MH**	23168EKW33MH**
	580	243	5	9	16,7	4800	9490	732	450	560	24168EW33MH**	24168EK30W33MH**
	620	224	6	12	22,3	4840	8200	625	450	560	23268EW33MH**	23268EKW33MH**
360	480	90	3	6	11,1	1430	3210	255	850	1100	23972EW33MH**	23972EKW33MH**
	540	134	5	12	22,3	2740	5080	395	670	850	23072EW33MH**	23072EKW33MH**
	540	180	5	9	16,7	3330	7110	552	500	630	24072EW33MH**	24072EK30W33MH**
	600	192	5	12	22,3	4250	7500	571	560	700	23172EW33MH**	23172EKW33MH**
	600	243	5	9	16,7	4870	9970	759	430	530	24172EW33MH**	24172EK30W33MH**
	650	232	6	12	22,3	5650	9230	660	430	530	23272EW33MH**	23272EKW33MH**
380	520	106	4	7,5	13,9	1850	4030	313	800	1000	23976EW33MH**	23976EKW33MH**
	560	135	5	12	22,3	2810	5370	412	630	800	23076EW33MH**	23076EKW33MH**
	560	180	5	9	16,7	3420	7420	569	480	600	24076EW33MH**	24076EK30W33MH**
	620	194	5	12	22,3	4380	7960	599	530	670	23176EW33MH**	23176EKW33MH**
	620	243	5	9	16,7	5000	10500	789	400	500	24176EW33MH**	24176EK30W33MH**
	680	240	6	12	22,3	5600	9550	706	400	500	23276EW33MH**	23276EKW33MH**
400	540	106	4	7,5	13,9	1900	4260	327	750	950	23980EW33MH**	23980EKW33MH**
	600	148	5	12	22,3	3120	6080	458	560	700	23080EW33MH**	23080EKW33MH**
	600	200	5	12	22,3	4050	8660	652	450	560	24080EW33MH**	24080EK30W33MH**
	650	200	6	12	22,3	4550	8750	649	500	630	23180EW33MH**	23180EKW33MH**
	650	250	6	12	22,3	5410	11200	827	380	480	24180EW33MH**	24180EK30W33MH**
	720	256	6	12	22,3	6300	10900	793	360	450	23280EW33MH**	23280EKW33MH**
	820	243	7,5	12	22,3	7060	11000	781	400	500	22380EW33MH**	22380EKW33MH**
420	560	106	4	7,5	13,9	1980	4490	340	700	900	23984EW33MH**	23984EKW33MH**
	620	150	5	12	22,3	3200	6520	485	530	670	23084EW33MH**	23084EKW33MH**
	620	200	5	12	22,3	4070	8820	656	400	500	24084EW33MH**	24084EK30W33MH**
	700	224	6	12	22,3	5420	10000	730	450	560	23184EW33MH**	23184EKW33MH**
	700	280	6	12	22,3	6440	13500	980	340	430	24184EW33MH**	24184EK30W33MH**
	760	272	7,5	12	22,3	6870	11800	845	340	430	23284EW33MH**	23284EKW33MH**

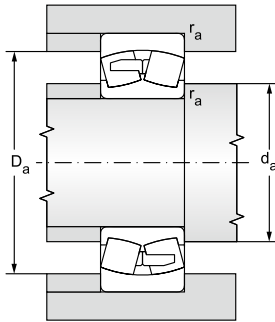

Abutment and fillet dimensions			Weight		Corresp. adapter sleeve	Corresp. withdrawal sleeve	Corresp. nut	Factors			
d _a	D _a	r _a	K					e	Y ₁	Y ₂	Y ₀
min	max	max									
mm			kg								
354	446	2,5	43,3	41,9	H3968	-	-	0,17	4	6	3,9
362	498	4	100	97,4	H3068	AH3068	HML73T	0,23	2,9	4,4	2,9
362	498	4	141	139	-	AOH24068	HM3072	0,33	2	3	2
362	558	4	201	195	H3168	AH3168	HM74T	0,3	2,2	3,3	2,2
362	558	4	206	199	H3168	AH3168	HM74T	0,3	2,2	3,3	2,2
362	558	4	271	267	-	AOH24168	HM3172	0,4	1,7	2,5	1,7
368	592	5	295	286	H3268	AH3268	HM74T	0,37	1,8	2,6	1,7
374	466	2,5	45,3	43,9	H3972	-	-	0,16	4,2	6,2	4,1
382	518	4	107	104	H3072	AH3072	HML77T	0,22	3,1	4,6	3
382	518	4	148	145	-	AOH24072	HM3076	0,3	2,2	3,3	2,2
382	578	4	217	210	H3172	AH3172	HM3180	0,3	2,3	3,4	2,2
382	578	4	284	279	-	AH24172	HM3176	0,38	1,8	2,6	1,7
388	622	5	332	322	H3272	AH3272	HM3180	0,35	1,9	2,9	1,8
398	502	3	66,1	63,9	H3976	-	-	0,18	3,8	5,7	3,8
402	538	4	112	109	H3076	AH3076	HML82T	0,21	3,2	4,7	3,1
402	538	4	154	152	-	AOH24076	HM3080	0,29	2,3	3,5	2,3
402	598	4	231	224	H3176	AH3176	HM3184	0,29	2,3	3,5	2,3
402	598	4	296	291	-	AOH24176	HM3180	0,36	1,9	2,8	1,8
408	652	5	372	360	H3276	AH3276	HM3184	0,36	1,9	2,7	1,8
418	522	3	69,4	67,1	H3980	-	-	0,17	4	5,9	3,9
422	578	4	145	140	H3080	AH3080	HML86T	0,22	3,1	4,6	3
422	578	4	200	197	-	AOH24080	HM3084	0,3	2,2	3,3	2,2
428	622	5	263	255	H3180	AH3180	HM3188	0,28	2,4	3,8	2,4
428	622	5	428	622	-	AOH24180	HM3184	0,35	1,9	2,8	1,9
428	692	5	450	437	H3280	AH3280	HM3188	0,36	1,8	2,7	1,8
436	784	6	603	591	H3280	AH3280	HM3188	0,29	2,3	3,5	2,3
438	542	3	72,3	69,9	H3984	-	-	0,16	4,2	6,3	4
442	598	4	154	149	H3084	AH3084	HML90T	0,21	3,1	4,7	3,1
442	598	4	206	203	-	AOH24084	HM3088	0,3	2,3	3,4	2,2
448	672	5	343	333	H3184	AH3184	HM3192	0,3	2,3	3,4	2,2
448	672	5	445	438	-	AOH24184	HM3188	0,37	1,8	2,7	1,8
456	724	6	535	520	H3284	AH3284	HM3192	0,36	1,7	2,7	1,8

Double row spherical roller bearings

d = 630 to 850 mm

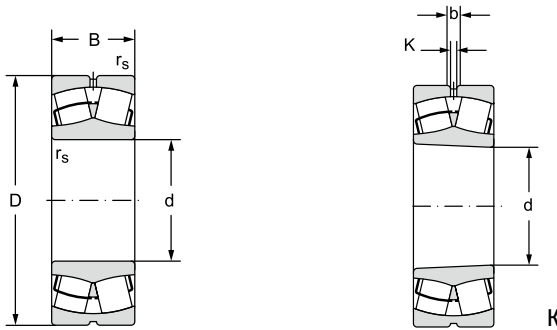

12.5.1

Main dimensions						Basic load rating		Fatigue load limit	Limiting speed for lubrication with		Bearing designation	
d	D	B	r _s	a	b	dynamic C _r	static C _{0r}	P _u	grease	oil	with cylindrical bore	with tapered bore
mm						kN		kN	min ⁻¹			
440	600	118	4	9	16,7	2290	5050	376	670	850	23988EW33MH**	23988EKW33MH**
	650	157	6	12	22,3	3500	7170	526	500	630	23088EW33MH**	23088EKW33MH**
	650	212	6	12	22,3	4390	9990	733	380	480	24088EW33MH**	24088EK30W33MH**
	720	226	6	12	22,3	5600	10600	766	430	530	23188EW33MH**	23188EKW33MH**
	720	280	6	12	22,3	6530	14000	1000	320	400	24188EW33MH**	24188EK30W33MH**
	790	280	7,5	12	22,3	7570	13200	933	320	400	23288EW33MH**	23288EKW33MH**
460	620	118	4	9	16,7	2310	5190	382	600	750	23992EW33MH**	23992EKW33MH**
	680	163	6	12	22,3	3800	7830	566	480	600	23092EW33MH**	23092EKW33MH**
	680	218	6	12	22,3	4650	10600	767	360	450	24092EW33MH**	24092EK30W33MH**
	760	240	7,5	12	22,3	6220	11950	847	400	500	23192EW33MH**	23192EKW33MH**
	760	300	7,5	12	22,3	7370	15500	1100	300	380	24192EW33MH**	24192EK30W33MH**
	830	296	7,5	12	22,3	8150	14100	983	300	380	23292EW33MH**	23292EKW33MH**
480	650	128	5	9	16,7	2680	6070	440	560	700	23996EW33MH**	23996EKW33MH**
	700	165	6	12	22,3	3910	8240	590	450	560	23096EW33MH**	23096EKW33MH**
	700	218	6	12	22,3	4870	11200	802	340	430	24096EW33MH**	24096EK30W33MH**
	790	248	7,5	12	22,3	6660	12900	901	380	480	23196EW33MH**	23196EKW33MH**
	790	308	7,5	12	22,3	7690	16300	1140	280	360	24196EW33MH**	24196EK30W33MH**
	870	310	7,5	12	22,3	9200	16500	1130	280	360	23296EW33MH**	23296EKW33MH**
500	670	128	5	9	16,7	2760	6220	447	530	670	239/500EW33MH**	239/500EKW33MH**
	720	167	6	12	22,3	4000	8300	588	430	530	230/500EW33MH**	230/500EKW33MH**
	720	218	6	12	22,3	4930	11500	815	320	400	240/500EW33MH**	240/500EK30W33MH**
	830	264	7,5	12	22,3	7300	14200	981	360	450	231/500EW33MH**	231/500EKW33MH**
	830	325	7,5	12	22,3	8540	17700	1220	260	340	241/500EW33MH**	241/500EK30W33MH**
	920	336	7,5	12	22,3	10400	18800	1270	260	340	232/500EW33MH**	232/500EKW33MH**
530	710	136	5	12	22,3	2970	6940	490	500	630	239/530EW33MH**	239/530EKW33MH**
	780	185	6	12	22,3	4780	9940	690	400	500	230/530EW33MH**	230/530EKW33MH**
	780	250	6	12	22,3	6050	14100	978	280	360	240/530EW33MH**	240/530EK30W33MH**
	870	272	7,5	12	22,3	7920	15500	1050	340	430	231/530EW33MH**	231/530EKW33MH**
	870	335	7,5	12	22,3	10100	19800	1340	240	320	241/530EW33MH**	241/530EK30W33MH**
	980	355	9,5	12	22,3	11600	20400	1360	240	320	232/530EW33MH**	232/530EKW33MH**
560	750	140	5	12	22,3	3300	7800	511	480	600	239/560EW33MH**	239/560EKW33MH**
	820	195	6	12	22,3	5280	11000	751	380	480	230/560EW33MH**	230/560EKW33MH**
	820	258	6	12	22,3	6430	15500	1060	260	340	240/560EW33MH**	240/560EK30W33MH**
	920	280	7,5	12	22,3	8580	16800	1120	320	400	231/560EW33MH**	231/560EKW33MH**
	920	355	7,5	12	22,3	10300	22100	1700	220	300	241/560EW33MH**	241/560EK30W33MH**
	1030	365	9,5	12	22,3	12400	22500	1680	240	320	232/560EW33MH**	232/560EKW33MH**

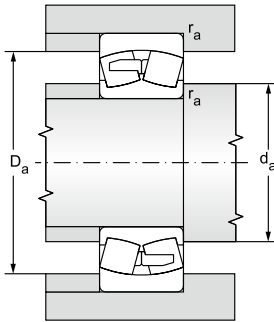

Abutment and fillet dimensions			Weight		Corresp. adapter sleeve	Corresp. withdrawal sleeve	Corresp. nut	Factors			
d _a	D _a	r _a	K					e	Y ₁	Y ₂	Y ₀
min	max	max									
mm			kg								
458	582	3	96	92,8	H3988	-	-	0,16	4,2	6,3	4
468	622	5	178	172	H3088	AH3088X	HML94T	0,21	3,2	4,7	3,1
468	622	5	240	236	-	AOH24088	HML92T	0,3	2,3	3,4	2,2
468	692	5	361	349	H3188	AH3188X	HM3196	0,29	2,3	3,5	2,3
468	692	5	465	458	-	AOH24188	HM3192	0,37	1,8	2,7	1,8
476	754	6	590	572	H3288	AH3288X	HM3196	0,36	1,8	2,7	1,8
478	602	3	101	98	H3992	-	-	0,16	4,1	6,1	4
488	652	5	202	196	H3092	AH3092X	HML98T	0,21	3,2	4,7	3,1
488	652	5	269	264	-	AOH24092	HML96T	0,28	2,4	3,6	2,4
496	724	6	436	423	H3192	AH3192X	HM102T	0,29	2,3	3,5	2,3
496	724	6	556	547	-	AOH24192	HM3196	0,37	1,8	2,7	1,8
496	794	6	690	669	H3292	AH3292X	HM102T	0,35	1,9	2,9	1,8
502	628	4	122	118	H3996	-	-	0,17	4	5,9	3,9
508	672	5	212	206	H3096	AH3096X	HML104T	0,21	3,2	4,8	3,2
508	672	5	279	274	-	AOH24096	HML100T	0,28	2,4	3,6	2,4
516	754	6	485	470	H3196	AH3196X	HM31/530	0,29	2,3	3,5	2,3
516	754	6	613	604	-	AOH24196	HM31/500	0,37	1,8	2,7	1,8
516	834	6	795	771	H3296	AH3296X	HM31/530	0,35	1,9	2,9	1,8
522	648	4	130	126	H39/500	-	-	0,17	4	5,9	4
528	692	5	221	213	H30/500	AH30/500X	HML108T	0,22	3	4,3	2,9
528	692	5	288	283	-	AOH240/500	HML106T	0,26	2,6	3,9	2,5
536	794	6	572	552	H31/500	AH31/500X	HM110T	0,31	2,1	3	2
536	794	6	720	709	-	AOH241/500	HM31/530	0,37	1,8	2,7	1,8
536	884	6	976	946	H32/500	AH32/500X	HM110T	0,35	1,9	2,9	1,9
552	668	4	156	151	H39/530	-	-	0,17	4	5,9	4
558	752	5	300	291	H30/530	AH30/530	HM30/560	0,22	3	4,3	2,9
558	752	5	402	396	-	AOH240/530	HML110T	0,28	2,4	3,6	2,4
566	834	6	640	620	H31/530	AH31/530	HM31/560	0,3	2,3	3,4	2,2
566	834	6	805	793	-	AOH241/530	HM110T	0,36	1,9	2,8	1,8
574	936	8	1180	1150	H32/530	AH32/530	HM116T	0,35	1,9	2,9	1,8
582	728	4	173	167	H39/560	-	-	0,16	4,2	6,3	4
588	792	5	345	334	H30/560	AH30/560X	HM30/600	0,22	3,1	4,6	3
588	792	5	472	464	-	AOH240/560	HML116T	0,28	2,4	3,5	2,3
596	884	6	736	713	H31/560	AH31/560	HM31/600	0,3	2,3	3,4	2,2
596	884	6	955	940	-	AOH241/560	HM116T	0,35	1,9	2,9	1,8
604	986	8	1330	1290	H32/560	AH32/560X	HM31/600	0,34	2	3	2

Double row spherical roller bearings

d = 900 to 1120 mm

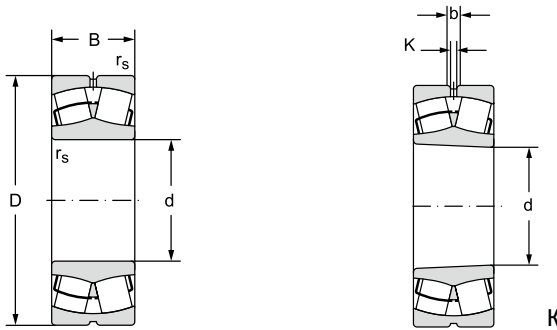

12.5.1

Main dimensions						Basic load rating		Fatigue load limit	Limiting speed for lubrication with		Bearing designation	
d	D	B	r _s	a	b	dynamic C _r	static C _{0r}	P _u	grease	oil	with cylindrical bore	with tapered bore
mm						kN		kN	min ⁻¹			
600	800	150	5	12	22,3	3650	9030	614	450	560	239/600EW33MH**	239/600EKW33MH**
	870	200	6	12	22,3	5580	11900	798	340	430	230/600EW33MH**	230/600EKW33MH**
	870	272	6	12	22,3	7500	17600	1180	240	320	240/600EW33MH**	240/600EK30W33MH**
	980	300	7,5	12	22,3	9750	19300	1270	300	380	231/600EW33MH**	231/600EKW33MH**
	980	375	7,5	12	22,3	11300	24500	1600	200	280	241/600EW33MH**	241/600EK30W33MH**
	1090	388	9,5	12	22,3	14000	25900	1670	220	300	232/600EW33MH**	232/600EKW33MH**
630	850	165	6	12	22,3	4300	10300	682	400	500	239/630EW33MH**	239/630EKW33MH**
	920	212	7,5	12	22,3	6430	13700	904	320	400	230/630EW33MH**	230/630EKW33MH**
	920	290	7,5	12	22,3	8060	19700	1300	220	300	240/630EW33MH**	240/630EK30W33MH**
	1030	315	7,5	12	22,3	10800	21700	1400	280	360	231/630EW33MH**	231/630EKW33MH**
	1030	400	7,5	12	22,3	12700	27900	1800	190	260	241/630EW33MH**	241/630EK30W33MH**
	1150	412	12	12	22,3	15400	28700	1820	200	280	232/630EW33MH**	232/630EKW33MH**
670	900	170	6	12	22,3	4620	11200	736	380	480	239/670EW33MH**	239/670EKW33MH**
	980	230	7,5	12	22,3	7300	16100	1040	300	380	230/670EW33MH**	230/670EKW33MH**
	980	308	7,5	12	22,3	9100	22500	1450	200	280	240/670EW33MH**	240/670EK30W33MH**
	1090	336	7,5	12	22,3	11900	24000	1520	260	340	231/670EW33MH**	231/670EKW33MH**
	1090	412	7,5	12	22,3	15200	31200	1920	180	240	241/670EW33MH**	241/670EK30W33MH**
	1220	438	12	12	22,3	17200	32300	2000	190	260	232/670EW33MH**	232/670EKW33MH**
710	950	180	6	12	22,3	5050	12500	808	360	450	239/710EW33MH**	239/710EKW33MH**
	1030	236	7,5	12	22,3	7750	17000	1080	280	360	230/710EW33MH**	230/710EKW33MH**
	1030	315	7,5	12	22,3	9540	23600	1500	190	260	240/710EW33MH**	240/710EK30W33MH**
	1150	345	9,5	12	22,3	12700	26400	1650	240	320	231/710EW33MH**	231/710EKW33MH**
	1150	438	9,5	12	22,3	15200	34700	2170	170	220	241/710EW33MH**	241/710EK30W33MH**
	1280	450	12	12	22,3	18700	35300	2160	180	240	232/710EW33MH**	232/710EKW33MH**
750	920	170	5	12	-	4160	12900	834	190	260	248/750EW20MH**	248/750EK30W20MH**
	1000	185	6	12	22,3	5380	13500	859	340	430	239/750EW33MH**	239/750EKW33MH**
	1090	250	7,5	12	22,3	8640	19200	1200	260	340	230/750EW33MH**	230/750EKW33MH**
	1090	335	7,5	12	22,3	10700	26600	1660	180	240	240/750EW33MH**	240/750EK30W33MH**
	1220	365	9,5	12	22,3	14500	29400	1800	220	300	231/750EW33MH**	231/750EKW33MH**
	1220	475	9,5	12	22,3	17400	39200	2400	160	200	241/750EW33MH**	241/750EK30W33MH**
	1360	475	15	12	22,3	19000	37000	2220	150	190	232/750CW33MH**	232/750CKW33MH**
	1360	475	15	12	22,3	19000	37000	2220	150	190	232/750CW33F**	232/750CKW33F**
800	1060	195	6	12	22,3	5920	15200	949	300	380	239/800EW33MH**	239/800EKW33MH**
	1150	258	7,5	12	22,3	10100	21600	1260	240	320	230/800EW33MH**	230/800EKW33MH**
	1150	345	7,5	12	22,3	11400	29100	1790	170	220	240/800EW33MH**	240/800EK30W33MH**
	1280	375	9,5	12	22,3	15300	32200	1940	200	280	231/800EW33MH**	231/800EKW33MH**
	1280	475	9,5	12	22,3	18200	41900	2530	150	190	241/800EW33FH**	241/800EK30W33FH**

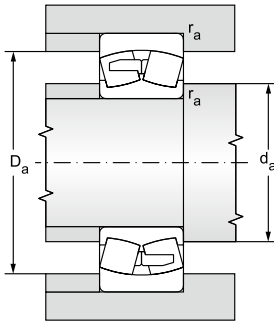

Abutment and fillet dimensions			Weight		Corresp. adapter sleeve	Corresp. withdrawal sleeve	Corresp. nut	Factors			
d _a	D _a	r _a	K					e	Y ₁	Y ₂	Y ₀
min	max	max									
mm			kg								
622	778	4	211	204	H39/600	-	-	0,16	4,2	6,2	4,1
628	842	5	392	380	H30/600	AH30/600X	HM30/630	0,22	3	4,6	2,8
628	842	5	551	542	-	AOH240/600X	HM31/630	0,28	2,4	3,6	2,4
636	944	6	890	861	H31/600	AH31/600X	HM31/630	0,3	2,3	3,4	2,2
636	944	6	1130	1110	-	AH241/600X	HM31/630	0,37	1,8	2,7	1,8
644	1046	8	1570	1520	H32/600	AH32/600X	HM130T	0,35	1,9	2,9	1,8
658	822	5	267	258	H39/630	-	-	0,17	4	5,9	4
666	884	6	470	455	H30/630	AH30/630	HM30/670	0,21	3,1	4,5	2,9
666	884	6	665	654	-	AOH240/630	HML130T	0,28	2,4	3,5	2,3
666	994	6	1030	1020	H31/630	AH31/630	HM31/670	0,3	2,2	3,3	2,2
666	994	6	1340	1320	-	AOH241/630	HM130T	0,37	1,8	2,7	1,8
678	1102	10	1860	1800	H32/630	AH32/630	HM136T	0,35	1,9	2,9	1,8
698	872	5	313	304	H39/670	-	-	0,17	4	5,9	4
706	944	6	580	562	H30/670	AH30/670	HM30/710	0,23	3	4,4	2,9
706	944	6	803	790	-	AOH240/670	HML138T	0,28	2,4	3,6	2,4
706	1054	6	1220	1200	H31/670	AH31/670X	HM31/710	0,28	2,4	3,6	2,3
706	1054	6	1540	1520	-	AOH241/670	HM142T	0,35	1,9	2,9	1,9
718	1172	10	2220	2160	H32/670	AH32/670	HM144T	0,35	1,9	2,9	1,8
738	922	5	361	349	H39/710	-	-	0,17	4	5,9	4
746	994	6	648	624	H30/710	AH30/710X	HM30/750	0,21	3,2	4,8	3,2
746	994	6	886	872	-	AOH240710	HML146T	0,27	2,5	3,7	2,4
754	1106	8	1390	1350	H31/710	AH31/710X	HM31/750	0,28	2,4	3,6	2,5
754	1106	8	1810	1780	-	AOH241/710	HM150T	0,35	1,9	2,8	1,9
758	1232	10	2500	2430	H32/710	AH32/710	HM31/750	0,35	1,9	2,9	1,8
768	902	4	247	243	-	-	-	0,15	4,4	6,6	4,3
778	972	5	405	391	H39/750	-	-	0,16	4,2	6,3	4
786	1054	6	770	742	H30/750	AH30/750	HM30/800	0,21	3,2	4,8	3,2
786	1054	6	1060	1040	-	AOH240/750	HML155T	0,28	2,4	3,6	2,4
794	1176	8	1670	1620	H31/750	AH31/750	HM31/800	0,28	2,4	3,6	2,4
794	1176	8	2100	2070	-	AOH241/750	HM155T	0,37	1,8	2,7	1,8
815	1295	12	3070	2990	H32/750	AH32/750	HM31/800	0,34	2	2,9	1,9
815	1295	12	3020	2940	H32/750	AH32/750	HM31/800	0,34	2	2,9	1,9
828	1032	5	474	458	H39/800	-	-	0,16	4,2	6,3	4
836	1114	6	884	842	H30/800	AH30/800	HM30/850	0,2	3,4	5,1	3,4
836	1114	6	1190	1170	-	AOH240/800	HML165T	0,27	2,5	3,7	2,5
844	1236	8	1800	1740	H31/800	AH31/800	HM31/850	0,28	2,4	3,6	2,4
844	1236	8	2220	2190	-	AOH241/800	HM165T	0,35	1,9	2,9	1,8

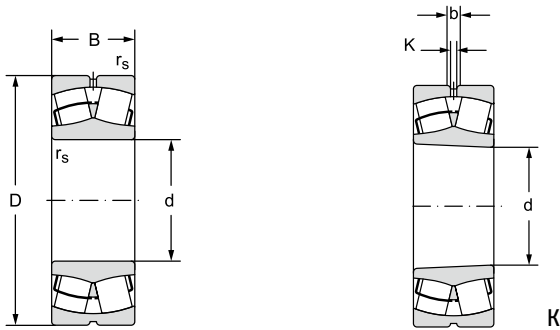

12.5.1

Main dimensions						Basic load rating		Fatigue load limit	Limiting speed for lubrication with		Bearing designation	
d	D	B	r _s	a	b	dynamic C _r	static C _{or}	P _u	grease	oil	with cylindrical bore	with tapered bore
mm						kN		kN	min ⁻¹			
850	1120	200	6	12	22,3	6380	16400	1020	280	360	239/850EW33MH**	239/850EKW33MH**
	1220	272	7,5	12	22,3	10300	23500	1420	220	300	230/850EW33MH**	230/850EKW33MH**
	1220	365	7,5	12	22,3	12600	31800	1920	160	200	240/850EW33MH**	240/850EK30W33MH**
	1360	400	12	12	22,3	17200	36600	2170	190	260	231/850EW33MH**	231/850EKW33MH**
	1360	500	12	12	22,3	20200	46300	2740	140	180	241/850EW33MH**	241/850EK30W33MH**
900	1180	206	6	12	22,3	6900	18300	1100	260	340	239/900EW33MH**	239/900EKW33MH**
	1280	280	7,5	12	22,3	11200	26100	1550	200	280	230/900EW33MH**	230/900EKW33MH**
	1280	375	7,5	12	22,3	13500	34400	2050	150	190	240/900EW33MH**	240/900EK30W33MH**
	1420	515	12	12	22,3	21200	51000	2980	130	170	241/900EW33FH**	241/900EK30W33FH**
950	1250	224	7,5	12	22,3	7830	21200	1260	240	320	239/950EW33MH**	239/950EKW33MH**
	1360	300	7,5	12	22,3	12500	29200	1710	190	260	230/950EW33MH**	230/950EKW33MH**
	1360	412	7,5	12	22,3	15500	41300	2410	130	170	240/950EW33FH**	240/950EK30W33FH**
	1500	545	12	12	22,3	23600	57100	3280	120	160	241/950EW33FH**	241/950EK30W33FH**
1000	1320	315	7,5	12	22,3	11200	32200	1880	130	170	249/1000EW33MH**	249/1000EK30W33MH**
	1420	308	7,5	12	22,3	13500	32400	1870	180	240	230/1000EW33FH**	230/1000EKW33FH**
	1420	412	7,5	12	22,3	16200	42900	2470	120	160	240/1000EW33FH**	240/1000EK30W33FH**
	1580	580	12	12	22,3	26300	64400	3640	110	150	241/1000EW33FH**	241/1000EK30W33FH**
1060	1500	325	9,5	12	22,3	14900	36100	2050	170	220	230/1060EW33FH**	230/1060EKW33FH**
	1500	438	9,5	12	22,3	18200	48200	2730	110	150	240/1060EW33FH**	240/1060EK30W33FH**
1120	1580	462	9,5	12	22,3	19600	53000	2960	100	130	240/1120EW33FH**	240/1120EK30W33FH**

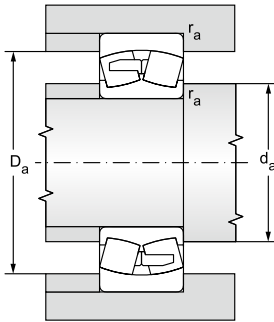

Abutment and fillet dimensions			Weight		Corresp. adapter sleeve	Corresp. withdrawal sleeve	Corresp. nut	Factors			
d_a	D_a	r_a	~ K					e	Y_1	Y_2	Y_0
min	max	max									
mm			kg								
878	1092	5	539	522	H39/850	-	-	0,16	4,2	6,3	4
886	1184	6	1030	1000	H30/850	AH30/850	HM30/900	0,21	3,1	4,5	3
886	1184	6	1410	1390	-	AOH240/850	HML175T	0,27	2,5	3,7	2,5
904	1306	10	2220	2150	H31/850	AH31/850	HM31/900	0,28	2,4	3,6	2,5
904	1306	10	2580	2530	-	AOH241/850	HM31/900	0,35	1,9	2,9	1,9
928	1152	5	603	583	H39/900	-	-	0,15	4,5	6,7	4,5
936	1244	6	1140	1100	H30/900	AH30/900	HM30/950	0,2	3,4	5	3,2
936	1244	6	1570	1550	-	AOH240/900	HM31/950	0,26	2,6	3,9	2,5
954	1366	10	3190	3150	-	AOH241/900	HM31/950	0,35	1,9	2,9	1,8
986	1214	6	746	721	H39/950	-	-	0,15	4,4	6,6	4,3
986	1324	6	1400	1350	H30/950	AH30/950	HM30/1000	0,2	3,4	5	3,2
986	1324	6	1970	1940	-	AOH240/950	HM31/1000	0,27	2,5	3,7	2,5
1004	1446	10	3370	3330	-	AOH241/950	HM31/1000	0,35	1,9	2,9	1,8
1036	1284	6	1180	1160	-	-	-	0,2	3,3	4,9	3,2
1036	1384	6	1540	1490	H30/1000	AH30/1000	HM30/1060	0,19	3,6	5,3	3,6
1036	1384	6	2120	2090	-	-	-	0,26	2,6	3,9	2,5
1054	1526	10	4100	4060	-	-	-	0,35	1,9	2,9	1,8
1104	1456	8	1800	1750	H30/1060	AH30/1060	HM30/1120	0,19	3,6	5,3	3,6
1104	1456	8	2490	2450	-	-	-	0,26	2,6	3,9	2,5
1164	1536	8	2900	2860	-	-	-	0,26	2,6	3,9	2,5





12.6 TAPERED ROLLER BEARINGS

Single row tapered roller bearings are detachable. The inner ring with tapered rolls and cage forms one assembly unit: the outer ring a second. The structure with a large number of tapered rolls in a single row allows these bearings to achieve a high radial and axial load capacity. Raceway contact surface areas lie on straight lines, which intersect in the bearing axis. Modifying the contact surfaces of raceways or tapered rolls, resp., limits the formation of edge stress. Axial loading may only occur in one direction and its magnitude depends on the size of the contact angle, which is characterized by the coefficient e . Bearings with a larger contact angle (type 313 and 323B) and thus with a larger coefficient e are more suitable for greater axial forces. A loading with single row tapered roller bearings usually comprises a pair of bearings due to capturing of axial loads in both directions. Bearings are structurally designed to higher utility parameters with the designation A. Bearings are manufactured both in metric and imperial dimensions.

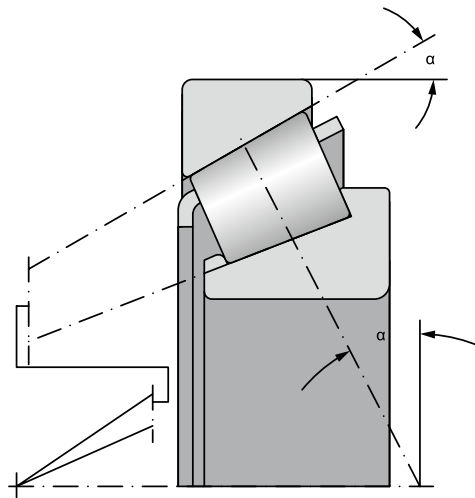

Fig. 12.6.1

Main dimensions

The main dimensions of metric single row tapered roller bearings conform to standard ISO 355. Main dimensions of single row tapered roller bearings in inches meet AFBMA Standard 19 (USA) from 1974.

Labelling

Labelling of standard bearings is specified in the tables of the publication. Divergence from the standard design is marked by the additional characters provided in chapter 7.6 of the catalogue. The current labelling, defined prior to 1977, as well as the new labelling according to ISO 355 is left as a guide in the tables of the publication for customers and manufacturers.

The original labelling is derived from the system described in chapter 7.6 of the catalogue.



In line with dimensional plan ISO 355, the labelling of metric single row tapered roller bearings is expressed using the alphanumeric characters as follows:

- T bearing type
- 2, 3, 4, 5, 7 angle series of bearing
- B, C, D, E, F, G diameter series of bearing
- B, C, D, E width series of bearing
- 000 bore diameter in mm

Imperial labelling of bearings corresponds to the common method used by most manufacturers of these bearings. The number before the fraction line designates the inner race with tapered rolls and cage. The number after the fraction line designates the outer bearing race.

Cage

Single row tapered roller bearings have a pressed steel plate cage, which is unmarked. The additional symbol J2 designates a new cage design.

Precision

Bearings are currently manufactured to a normal degree of precision – P0. The marking is not specified. Greater precision bearings P6, P6X, and P5 are supplied for loadings with high precision demands or high operating speeds. Delivery of bearings with precisions P6X and P5 should be negotiated in advance.

Inner clearance

Single row tapered roller bearings are usually installed in pairs, in which the required clearance or pre-load, as necessary, are set during installation. The clearance size or pre-load are determined according to the loading requirements.

Running-in and setting

When installing a pair of tapered roller bearings opposite each other, the bearings must turn to enable correct setting of tapered rolls by functional ball ends in the support flange. Bearings may exhibit somewhat greater friction and thus greater operating temperatures following installation. This will decrease and stabilize after several hours of controlled run-in.

Self-alignment ability

The seating surfaces for these bearings must be aligned with very small deviations, since the permissible self-alignment ability of rings is very small. The self-alignment ability under standard operating conditions

- under small loads ($F_r \leq 0.1C_{or}$) 1' to 1.5'
- under large loads ($F_r > 0.1C_{or}$) 2' to 4'

Minimal load

Minimal load is necessary to ensure reliable bearing operation, especially in loadings with high speeds, large angular acceleration, and rapid changes in the direction of loading forces. If the minimal load is not secured, then damage may occur to functional surfaces through slippage of rolling elements. Slippage is caused by the inertial mass of tapered rolls and the cage, partially also by friction of the lubricant. Recommended minimal load:

$$F_{r \min} = 0,02C \quad [\text{kN}]$$

C dynamic load capacity [kN]

If the assembly cannot secure this minimal load, then assistance is provided by setting the controlled pre-load in the loading.

Loading of bearings in inch dimensiones

Loading tolerances of these bearings can be selected according to metric bearing tolerances. Due to different tolerances of connecting diameters (deviations in both the bore and surface are positive), however, corrected values from the tables, specified below, must be used. The clearances and overlaps will then correspond to metric values.



Table 12.6.1

Corrected shaft tolerances for bearings in inch dimensiones													
Bore		g6		h6		j5		j6		js6		k5	
over	up to	max	min	max	min	max	min	max	min	max	min	max	min
mm						µm							
10	18	+2	-4	+8	+2	+13	+10	+16	+10	+14	+7	+17	+14
18	30	+3	-7	+10	0	+15	+9	+19	+9	+17	+6	+21	+15
30	50	+3	-12	+12	-3	+18	+8	+23	+8	+20	+5	+25	+15
50	76,2	+5	-16	+15	-6	+21	+6	+27	+6	+25	+3	+30	+15
76,2	80	+5	-4	+15	+6	+21	+18	+27	+18	+25	+15	+30	+27
80	120	+8	-9	+20	+3	+26	+16	+33	+16	+31	+14	+38	+28
120	180	+11	-14	+25	0	+32	+14	+39	+14	+38	+12	+46	+28
180	250	+15	-19	+30	-4	+37	+12	+46	+12	+45	+10	+54	+29
250	304,8	+18	-24	+35	-7	+42	+9	+51	+9	+51	+9	+62	+29
304,8	315	+18	+2	+35	+19	+42	+35	+51	+35	+51	+35	+62	+55
315	400	+22	-3	+40	+15	+47	+33	+58	+33	+58	+33	+69	+55
400	500	+25	-9	+45	+11	+52	+31	+65	+31	+65	+31	+77	+56
500	609,6	+28	-15	+50	+7	-	-	+72	+29	+72	+29	+78	+51
609,6	630	+28	+10	+50	+32	-	-	+72	+54	+72	+54	+78	+76
630	800	+51	+2	+75	+26	-	-	+100	+51	+100	+51	-107	+76
800	914,4	+74	-6	+100	+20	-	-	+128	+48	+128	+48	+136	+76

Table 12.6.2

Corrected shaft tolerances for bearings in inch dimensions											
Bore		k6		m5		m6		n6		p6	
over	up to	max	min	max	min	max	min	max	min	max	min
mm						µm					
10	18	+20	+14	+23	+20	+26	+20	+31	+25	+37	+31
18	30	+25	+15	+27	+21	+31	+21	+38	+28	+45	+35
30	50	+30	+15	+32	+22	+37	+22	+45	+30	+54	+39
50	76,2	+36	+15	+39	+24	+45	+24	+54	+33	+66	+45
76,2	80	+36	+27	+39	+36	+45	+36	+54	+45	+66	+57
80	120	+45	+28	+48	+38	+55	+38	+65	+48	+79	+62
120	180	+53	+28	+58	+40	+65	+40	+77	+52	+93	+68
180	250	+63	+29	+67	+42	+76	+42	+90	+56	+109	+75
250	304,8	+71	+29	+78	+45	+87	+45	+101	+59	+123	+81
304,8	315	+71	+55	+78	+71	+87	+71	+101	+85	+123	+107
315	400	+80	+55	+86	+72	+97	+72	+113	+88	+138	+113
400	500	+90	+56	+95	+74	+108	+74	+125	+91	+153	+119
500	609,6	+94	+51	+104	+77	+120	+77	+138	+95	+172	+129
609,6	630	+94	+76	+104	+102	+120	+102	+138	+120	+172	+154
630	800	+125	+76	+137	+106	+155	+106	+175	+126	+213	+164
800	914,4	+156	+76	+170	+110	+190	+110	+212	+132	+256	+176

Table 12.6.3

Corrected shaft tolerances for bearings in inch dimensions											
Bore		H7		J7		J6		K6		K7	
over	up to	max	min	max	min	max	min	max	min	max	min
mm						µm					
30	50	+36	+25	+25	+14	+21	+19	+14	+12	+18	+7
50	80	+43	+25	+31	+13	+26	+19	+17	+10	+22	+4
80	120	+50	+25	+37	+12	+31	+19	+19	+7	+25	0
120	150	+58	+25	+44	+11	+36	+18	+22	+4	+30	-3
150	180	+65	+25	+51	+11	+43	+18	+29	+4	+37	-3
180	250	+76	+25	+60	+9	+52	+18	+35	+1	+43	-8
250	304,8	+87	+25	+71	+9	+60	+18	+40	-2	+51	-11
304,8	315	+87	+51	+71	+35	+60	+44	+40	+24	+51	+15
315	400	+97	+51	+79	+33	+69	+44	+47	+22	+57	+11
400	500	+108	+51	+88	+31	+78	+44	+53	+19	+63	+6
500	609,6	+120	+51	-	-	-	-	+50	+7	+50	-19
609,6	630	+120	+76	-	-	-	-	+50	+32	+50	+6
630	800	+155	+76	-	-	-	-	+75	+26	+75	-4
800	914,4	+190	+76	-	-	-	-	+100	+20	+100	-14
914,4	1000	+190	+102	-	-	-	-	+100	+46	+100	+12
1000	1219,2	+230	+102	-	-	-	-	+125	+36	+125	-3

Table 12.6.4

Corrected bore tolerances for bearings in inch dimensions									
Bore		M6		M7		N7		P7	
over	up to	max	min	max	min	max	min	max	min
mm					µm				
30	50	+7	+5	+11	0	+3	-8	-6	-17
50	80	+8	+1	+13	-5	+4	-14	-8	-26
80	120	+9	-3	+15	-10	+5	-20	-9	-34
120	150	+10	-8	+18	-15	+6	-27	-10	-43
150	180	+17	-8	+25	-15	+13	+27	-3	-43
180	250	+22	-12	+30	-21	+16	-35	-3	-54
250	304,8	+26	-16	+35	-27	-21	-41	-1	-37
304,8	315	+26	+10	+35	-1	+21	-15	-1	-37
315	400	+30	+5	+40	-6	+24	-22	-1	-47
400	500	+35	+1	+45	-12	+28	-29	0	-57
500	609,6	+24	-19	+24	-45	+6	-63	-28	-97
609,6	630	+24	+6	+24	-20	+6	-38	-28	-72
630	800	+45	-4	+45	-34	+25	-54	-13	-92
800	914,4	+66	-14	+66	-48	+44	-70	0	-114
914,4	1000	+66	+12	+66	-22	+44	-44	0	-88
1000	1219,2	+85	-4	+85	-43	+59	-69	+5	-123



Radial equivalent dynamic load

$$P_r = F_r \quad \text{for } F_a / F_r \leq e \quad [\text{kN}]$$

$$P_r = 0.4F_r + YF_a \quad \text{for } F_a / F_r > e \quad [\text{kN}]$$

The values of coefficients e and Y for individual bearings are listed in the tables of the publication. If the shaft is set in two single row tapered roller bearings, an inner auxiliary force is created during radial loading. The load magnitude of a single bearing is proportional to the load and the contact angle of the second bearing. Auxiliary internal forces in the loading must be factored into the calculation. Table 12.6.5 lists relationships for various bearing arrangements when subject to an external axial force K_a , radial force F_{rA} , F_{rB} acting on bearing A and B. Radial forces act at the intersection of the line with the bearing axis (dimensions "a", "s" are provided in the tables) and are considered to have a positive value, even when their direction differs from that depicted on the figure. The calculated force F_a is substituted into the calculation of the radial equivalent dynamic load.

Radial equivalent static load

$$P_{or} = 0.5F_r + Y_0F_a \quad (P_{or} \geq F_r) \quad [\text{kN}]$$

The values of coefficients Y_0 for individual bearings are listed in the tables of the publication.

Table 12.6.5

Bearing arrangement	Force ratios		Axial loading of bearings	
			Bearing A	Bearing B
Fig. 12.6.2 a 12.6.3	$F_{rA}/Y_A \leq F_{rB}/Y_B$	$K_a \geq 0$	$F_{aB} = 0,5F_{rB}/Y_B$	$F_{aA} = F_{aB} + K_a$
Fig. 12.6.2 a 12.6.3	$F_{rA}/Y_A > F_{rB}/Y_B$	$K_a \geq 0,5 (F_{rA}/Y_A - F_{rB}/Y_B)$	$F_{aA} = F_{aB} + K_a$	$F_{aB} = 0,5F_{rA}/Y_A$
Fig. 12.6.2 a 12.6.3	$F_{rA}/Y_A > F_{rB}/Y_B$	$K_a \geq 0,5 (F_{rB}/Y_B - F_{rA}/Y_A)$	$F_{aA} = 0,5F_{rA}/Y_A$	$F_{aB} = F_{aA} - K_a$
Fig. 12.6.4 a 12.6.5	$F_{rA}/Y_A \geq F_{rB}/Y_B$	$K_a \geq 0$	$F_{aA} = 0,5F_{rA}/Y_A$	$F_{aB} = F_{aA} + K_a$
Fig. 12.6.4 a 12.6.5	$F_{rA}/Y_A < F_{rB}/Y_B$	$K_a \geq 0,5 (F_{rB}/Y_B - F_{rA}/Y_A)$	$F_{aA} = 0,5F_{rA}/Y_A$	$F_{aB} = F_{aA} + K_a$
Fig. 12.6.4 a 12.6.5	$F_{rA}/Y_A < F_{rB}/Y_B$	$K_a < 0,5 (F_{rB}/Y_B - F_{rA}/Y_A)^{1)}$	$F_{aA} = F_{aB} - K_a$	$F_{aB} = 0,5F_{rB}/Y_B$

¹⁾ Applies also for $K_a = 0$

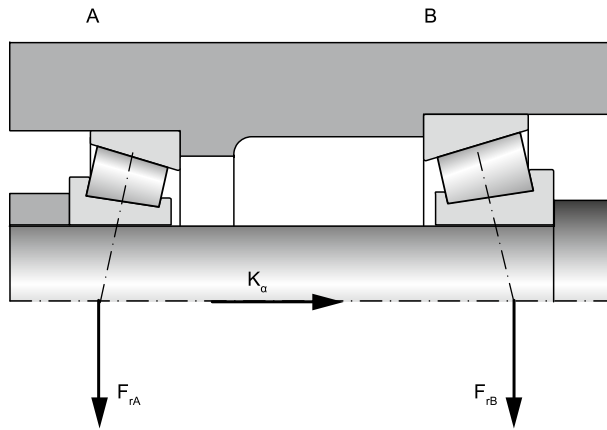

Fig. 12.6.2

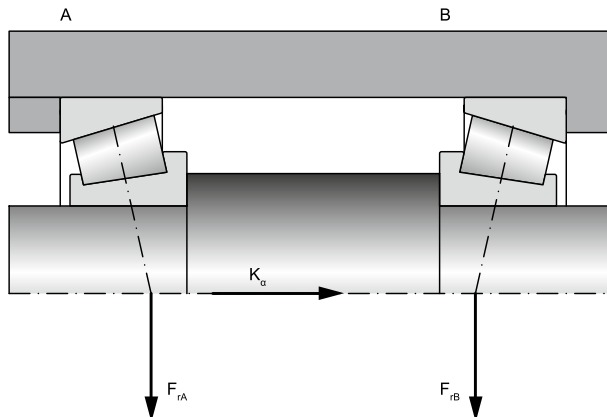

Fig. 12.6.3

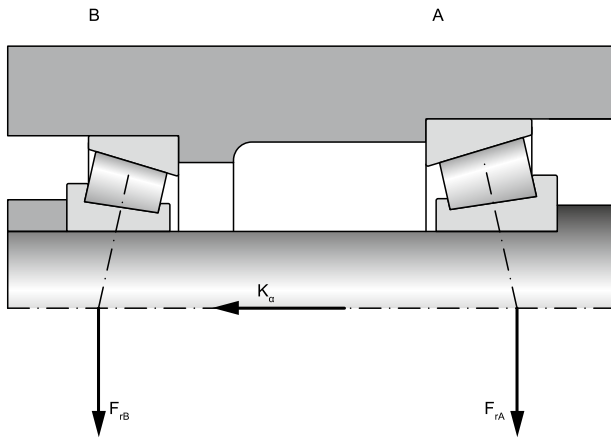

Fig. 12.6.4

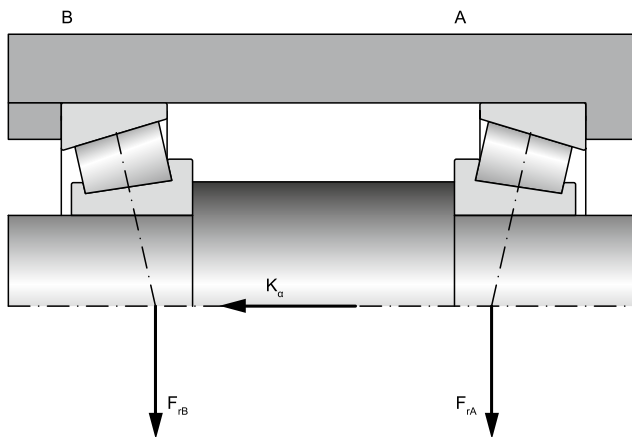
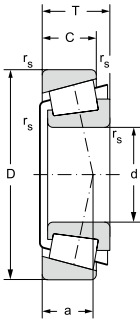

Fig. 12.6.5



Single row tapered roller bearings in metric dimensions d = 15 to 320 mm

d = 15 to 35 mm



12.6.1

Main dimensions									Basic load rating		Fatigue load limit	Limiting speed for lubrication with	
d	D	B	C	T	r _{1s}	r _{2s}	r _{3s}	a	dynamic	static	P _u	grease	oil
					min	min	min		C _r	C _{or}			
mm									kN		kN	min ⁻¹	
15	35	11	10	11,75	0,6	0,6	0,3	10	15,2	14,6	1,8	11000	15000
	42	13	11,0	14,25	1,0	1,0	0,3	9,6	22,9	21,6	2,6	10000	14000
17	40	12	11	13,25	1	1	0,3	10	22,2	21,8	2,7	9500	13000
	47	14	12,0	15,25	1,0	1,0	0,3	11	25,1	22,8	2,8	10000	13000
	47	19	16	20,25	1	1	0,3	12	35,4	34,3	3,9	8500	11000
20	42	15	12,0	15,00	0,6	0,6	0,3	10	22,8	29	3,5	9000	13000
	47	14	12,0	15,25	1,0	1,0	0,3	11	25,1	26,1	3,2	8900	12000
	52	15	13,0	16,25	1,5	1,5	0,6	11	30,4	29,9	3,6	8400	11000
	52	21	18,0	22,25	1,5	1,5	0,6	13	43,8	45,5	5,5	8400	11000
25	47	15	11,5	15,00	0,6	0,6	0,3	12	24,2	28,7	3,5	8400	11000
	52	15	13,0	16,25	1,0	1,0	0,3	12	29,9	33,5	4,1	7500	10000
	52	18	16,0	19,25	1,0	1,0	0,3	13,5	36,4	43,2	5,3	7900	11000
	52	22	18,0	22,00	1,0	1,0	0,3	14,1	48,9	58,5	7,1	7900	10000
	62	17	15,0	18,25	1,5	1,5	0,6	13	43,8	42,1	5,1	6900	9200
	62	17	15,0	18,25	1,5	1,5	0,6	13	39,8	38,3	4,7	7100	9400
	62	17	13,0	18,25	1,5	1,5	0,6	20	36,2	39,1	4,8	6700	8900
	62	24	20,0	25,25	1,5	1,5	0,6	15	57,3	60,7	7,4	6700	8900
30	55	17	13,0	17,00	1,0	1,0	0,3	13	35,5	43,8	5,3	7100	9400
	62	16	14,0	17,25	1,0	1,0	0,3	14	39,3	42,8	5,2	6500	8700
	62	16	14,0	17,25	1,0	1,0	0,3	14	40,6	44,7	5,5	6700	8900
	62	20	17,0	21,25	1,0	1,0	0,3	15	50,1	59,6	7,3	6700	8900
	62	25	19,5	25	1	1	0,3	16	68	82	9,9	6000	8000
	72	19	16,0	20,75	1,5	1,5	0,6	15	53,1	53,1	6,5	5600	7500
	72	19	14,0	20,75	1,5	1,5	0,6	23	46,4	50,1	6,1	5300	7100
	72	27	23,0	28,75	1,5	1,5	0,6	20	76,4	85,8	10	5600	7500
32	58	17	13,0	17,00	1,0	1,0	0,3	14	39,8	48,2	5,9	7100	9400
35	62	18	14,0	18,00	1,0	1,0	0,3	15	43	53,1	6,5	6300	8400
	72	17	15,0	18,25	1,5	1,5	0,6	15	46,4	51,1	6,2	5300	7100
	72	23	19,0	24,25	1,5	1,5	0,6	17	64,3	76,4	9,3	5300	7100
	72	28	22	28	1,5	1,5	0,6	18	83	102	12	5300	7100
	80	21	18,0	22,75	2,0	2,0	0,6	16	65,6	69,4	8,5	5000	6700
80	21	15,0	22,75	2,0	1,5	0,6	26	57,3	63,1	7,7	4700	6300	
80	31	25,0	32,75	2,0	1,5	0,6	20	94,4	110	13	4700	6300	

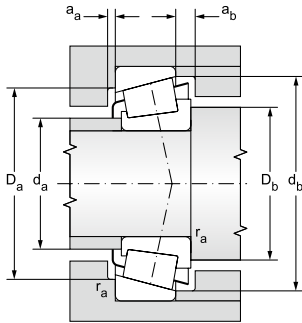

Bearing designation		Abutment and fillet dimensions									Weight	Factors		
ČSN	ISO	d	d _a	d _b	D _a	D _b	D _b	a _a	a _b	r _a	~	e	Y	Y ₀
		mm									kg			
			max	min	min	max	min	min	min	max				
30202		15	21	21	29	30	32	2	2	0,6	0,06	0,24	2,53	1,39
30302A	T2FB015		22	21	35,0	36	38,0	2	3,0	1,0	0,094	0,29	2,10	1,1
30203	T2DB017	17	23	23	34	34	37	2	2	1	0,08	0,34	1,74	0,96
30303AJ2	T2FB017		25	23	39,0	41	42,0	2	3,0	1,0	0,14	0,29	2,10	1,2
32303	T2FD017		24	23	39	41	43	3	4	1	0,18	0,18	3,26	1,79
32004AX	T3CC020	20	25	25	36,0	37	39,0	3	3,0	0,6	0,1	0,37	1,60	0,9
30204A	T2DB020		26	26	39,0	41	43,0	2	3,0	1,0	0,14	0,35	1,70	1,0
30304A	T2FB020		27	27	43,0	45	47,0	2	3,0	1,0	0,18	0,30	2,00	1,1
32304A	T2FD020		27	27	43,0	45	47,0	2	4,0	1,0	0,27	0,30	2,00	1,1
32005AX	T4CC025	25	30	31	40,5	42	44,0	3	3,5	0,6	0,12	0,43	1,40	0,8
30205A	T3CC025		31	31	43,0	46	48,0	2	3,0	1,0	0,17	0,37	1,60	0,9
32205F			31	31	43,0	46	48,0	2	3,0	1,0	0,2	0,36	1,03	0,8
33205F			30	31	43,0	46	49,0	4	4,0	1,0	0,23	0,35	1,71	0,9
30305A	T2FB025		33	32	53,0	55	57,0	2	3,0	1,0	0,29	0,30	2,00	1,1
30305AJ2	T2FB025		33	32	53,0	55	57,0	2	3,0	1,0	0,27	0,30	2,00	1,1
31305A	T7FB025		33	32	46,0	55	59,0	2	5,0	1,0	0,27	0,83	0,70	0,4
32305A	T2FD025		33	32	53,0	55	57,0	2	5,0	1,0	0,4	0,30	2,00	1,1
32006AX	T4CC030	30	35	36	47,5	49	52,0	3	4,0	1,0	0,18	0,43	1,40	0,8
30206A	T3DB030		37	36	52,0	56	57,0	2	3,0	1,0	0,25	0,37	1,60	0,9
30206AJ2	T3DB030		37	36	52,0	56	57,0	2	3,0	1,0	0,25	0,37	1,60	0,9
32206A	T3DC030		37	36	52,0	56	58,5	2	4,0	1,0	0,32	0,37	1,60	0,9
33206	T2DE030		36	36	53	56	59	5	5,5	0,5	0,35	0,24	2,53	1,39
30306A	T2FB030		38	37	61,0	65	66,0	2	4,5	1,0	0,42	0,32	1,90	1,1
31306AJ2	T7FB030		39	37	55,0	65	68,0	2	6,5	1,0	0,39	0,83	0,70	0,4
32306A	T2FD030		38	37	61,0	65	66,0	2	5,5	1,0	0,63	0,32	1,90	1,1
320/32AX	T4CC032	32	38	38	50,0	52	55,0	3	4,0	1,0	0,2	0,45	1,30	0,7
32007AX	T4CC035	35	40	41	54,0	56	59,0	4	4,0	1,0	0,24	0,45	1,30	0,7
30207A	T3DB035		43	42	61,0	65	67,0	3	3,0	1,0	0,36	0,37	1,60	0,9
32207A	T3DC035		43	42	61,0	65	68,5	3	5,0	1,0	0,48	0,37	1,60	0,9
33207	T2DE035		42	42	61	63	68	5	6	1	0,59	0,37	1,62	0,89
30307A	T2FB035		43	44	68,0	71	74,0	3	4,5	1,5	0,55	0,32	1,90	1,1
31307AJ2	T7FB035		43	44	61,0	71	76,0	3	7,5	1,5	0,52	0,83	0,70	0,4
32307A	T2FE035		43	44	68,0	71	74,0	3	7,5	1,5	0,83	0,32	1,90	1,1



Single row tapered roller bearings in metric dimensions

d = 40 to 50 mm

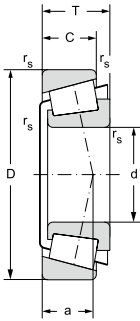

12.6.1

Main dimensions									Basic load rating		Fatigue load limit	Limiting speed for lubrication with	
d	D	B	C	T	r _{1s}	r _{2s}	r _{3s}	a	dynamic	static	P _u	grease	oil
					min	min	min		C _r	C _{or}			
mm									kN		kN	min ⁻¹	
40	68	19	14,5	19,00	1,0	1,0	0,3	15	48,2	64,3	7,8	5300	7100
	75	26	20,5	26	1,5	1,5	0,6	18	82	107	13	4800	6700
	80	18	16,0	19,75	1,5	1,5	0,6	17	55,2	60,7	7,4	4700	6300
	80	23	19,0	24,75	1,5	1,5	0,6	18	70,8	85,5	10	4700	6300
	80	32	25	32	1,5	1,5	0,6	21	114	142	17	4800	6300
	90	23	20,0	25,25	2,0	1,5	0,6	18	84,3	93,2	11	4500	6000
	90	23	20,0	25,25	2,0	1,5	0,6	19	82,5	94,4	12	4500	6000
	90	23	17,0	25,25	2,0	1,5	0,6	29	76,4	85,8	10	4000	5300
	90	33	27,0	35,25	2,0	1,5	0,6	22	114	141	17	4200	5600
	90	33	27,0	35,25	2,0	1,5	0,6	27	104,2	136,6	17	4100	5400
90	33	27,0	35,25	2,0	1,5	0,6	27	104	144	18	4200	5600	
45	75	20	15,5	20,00	1,0	1,0	0,3	17	57,3	79,4	9,7	4700	6300
	75	24	19	24	1	1	0,6	16	76	106	13	4800	6300
	80	26	20,5	26	1,5	1,5	0,6	19	89	122	15	4500	6000
	85	19	16,0	20,75	1,5	1,5	0,6	18	61,9	70,8	8,6	4500	6000
	85	23	19,0	24,75	1,5	1,5	0,6	20	73,6	90,9	11	4500	6000
	85	32	25	32	1,5	1,5	0,6	22	118	153	19	4300	6000
	100	25	22,0	27,25	2,0	1,5	0,6	21	107	118	14	4000	5300
	100	25	22,0	27,25	2,0	1,5	0,6	21	104	117	14	4000	5300
	100	25	18,0	27,25	2,0	1,5	0,6	32	92,6	104	13	3800	5000
	100	36	30,0	38,25	2,0	1,5	0,6	25	144	181	22	3800	5000
100	36	30,0	38,25	2,0	1,5	0,6	31	131	174	21	3800	5000	
50	80	20	15,5	20,00	1,0	1,0	0,3	18	59,6	87,4	11	4500	6000
	80	24	19	24	1	1	0,6	17	81	115	14	4300	6000
	85	26	20	26	1,5	1,5	0,6	20	92	110	13	4300	5600
	90	20	17,0	21,75	1,5	1,5	0,6	20	70,8	87,4	11	4200	5600
	90	23	19,0	24,75	1,5	1,5	0,6	21	81	102	12	4200	5600
	90	32	24,5	32	1,5	1,5	0,6	23	122	163	20	4000	5300
	110	27	23,0	29,25	2,5	2,0	0,6	23	121	141	17	3800	5000
	110	27	19,0	29,25	2,5	2,0	0,6	35	102	114	14	3300	4500
	110	40	33,0	42,25	2,5	2,0	0,6	27	174	224	27	3300	4500
	110	40	33,0	42,25	2,5	2,0	0,6	33	156	212	26	3200	4400

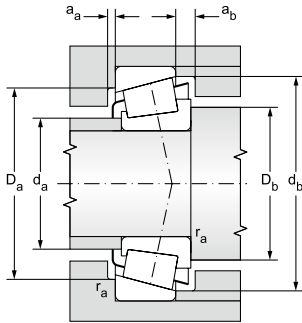

Bearing designation		Abutment and fillet dimensions									Weight	Factors			
ČSN	ISO	d	d_a	d_b	D_a	D_a	D_b	a_a	a_b	r_a	~	e	Y	Y0	
			max	min	min	max	min	min	min	max					
			mm									kg			
32008AX	T3CD040	40	45	46	60,0	62	65,0	4	4,5	1,0	0,29	0,38	1,60	0,9	
33108	T2CE040		47	47	65	66	71	4	5,5	1	0,52	0,26	2,27	1,25	
320208A	T3DB040		48	47	68,0	73	75,5	3	3,5	1,0	0,45	0,37	1,60	0,9	
32208A	T3DC040		48	47	68,0	73	75,0	3	5,5	1,0	0,55	0,37	1,60	0,9	
33208	T2DE040		47	47	67	71	76	5	7	1	0,74	0,36	1,68	0,92	
30308A	T2FB040		50	49	76,0	81	82,0	3	5,0	1,5	0,77	0,35	1,70	1,0	
30308AJ2	T2FB040		50	49	76,0	81	82,0	3	5,0	1,5	0,77	0,35	1,70	1,0	
31308A	T7FB040		50	49	70,0	81	86,0	3	8,0	1,5	0,78	0,83	0,70	0,4	
32308A	T2FD040		50	49	76,0	81	82,0	3	8,0	1,5	1,12	0,35	1,70	1,0	
32308BA	T5FD040		50	49	70,0	81	85,0	4	8,0	1,5	1,11	0,54	1,10	0,6	
32308BAJ2	T5FD040		50	49	70,0	81	85,0	4	8,0	1,5	0,99	0,54	1,10	0,6	
32009AX	T3CC045	45	50	51	66,0	69	72,0	4	4,5	1,0	0,36	0,39	1,50	0,8	
33009	T2CE045		52	52	67	69	78	5	7	0,5	0,43	0,29	2,04	1,12	
33109	T3CE045		52	52	69	71	77	4	5,5	1	0,53	0,29	2,06	1,13	
30209A	T3DB045		53	52	73,0	78	80,0	3	4,5	1,0	0,53	0,41	1,50	0,8	
32209A	T3DC045		53	52	73,0	78	81,5	3	5,5	1,0	0,64	0,41	1,50	0,8	
33209	T3DE045		52	52	72	76	81	5	7	1	0,79	0,39	1,56	0,86	
30309A	T2FB045		56	54	85,0	91	92,0	3	5,0	1,5	1,04	0,35	1,70	1,0	
30309AJ2	T2FB045		56	54	85,0	91	92,0	3	5,0	1,5	1,04	0,35	1,70	1,0	
31309A	T7FB045		55	54	78,0	91	95,0	3	9,0	1,5	1,03	0,83	0,70	0,4	
32309A	T2FD045		56	54	85,0	91	93,0	3	8,0	1,5	1,53	0,35	1,70	1,0	
32309BAJ2	T5FD045		55	54	76,0	91	94,0	5	8,0	1,5	1,54	0,54	1,10	0,6	
32010AX	T3CC050	50	55	56	71,0	74	77,0	4	4,5	1,0	0,4	0,42	1,40	0,8	
33010	T2CE050		56	56	72	74	76	4	5	0,5	0,42	0,32	1,9	1,04	
33110	T3CE050		56	57	74	76	82	4	6	1	0,6	0,32	1,88	1,04	
30210A	T3DB050		58	57	78,0	83	86,5	3	4,5	1,0	0,6	0,42	1,40	0,8	
32210A	T3DC050		58	57	78,0	83	85,0	3	5,5	1,0	0,67	0,42	1,40	0,8	
33210	T3DE050		57	57	77	81	87	5	7,5	1	0,85	0,42	1,43	0,79	
30310A	T2FB050		62	60	94,0	100	102,0	3	6,0	2,0	1,32	0,35	1,70	1,0	
31310A	T7FB050		61	60	85,0	100	104,0	3	10,0	2,0	1,29	0,83	0,70	0,4	
32310A	T2FD050		62	60	94,0	100	102,0	3	9,0	2,0	2,01	0,35	1,70	1,0	
32310BA	T5FD050		62	60	83,0	100	103,0	5	9,0	2,0	1,99	0,54	1,10	0,6	



Single row tapered roller bearings in metric dimensions

d = 55 to 70 mm

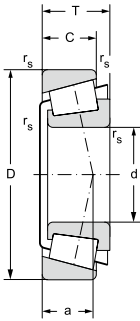

12.6.1

Main dimensions									Basic load rating		Fatigue load limit	Limiting speed for lubrication with	
d	D	B	C	T	r _{1s}	r _{2s}	r _{3s}	a	dynamic	static	P _u	grease	oil
					min	min	min		C _r	C _{or}			
mm									kN		kN	min ⁻¹	
55	90	23	17,5	23,00	1,5	1,5	0,6	20	76,4	108	13	4000	5300
	90	27	21	27	1,5	1,5	0,6	19	100	150	18	3800	5300
	95	30	23	30	1,5	1,5	0,6	22	114	160	20	3800	5000
	100	21	18,0	22,75	2,0	1,5	0,6	21	81	96,2	12	3800	5000
	100	25	21,0	26,75	2,0	1,5	0,6	22	102	128	16	3800	5000
	100	35	27	35	2	1,5	0,6	26	154	207	25	3600	5000
	120	29	25,0	31,50	2,5	2,0	0,6	25	136	162	20	3300	4500
	120	29	21,0	31,50	2,5	2,0	0,6	38	117	136	17	3000	4000
	120	43	35,0	45,50	2,5	2,0	0,6	29	200	256	31	3300	4500
60	95	23	17,5	23,00	1,5	1,5	0,6	21	81	119	15	3800	5000
	95	27	21	27	1,5	1,5	1	20	102	157	19	3600	5000
	100	30	23	30	1,5	1,5	1	23	110	174	21	3400	4800
	110	22	19,0	23,75	2,0	1,5	0,6	22	94,4	117	14	3300	4500
	110	28	24,0	29,75	2,0	1,5	0,6	25	126	162	20	3300	4500
	110	38	29	38	2	1,5	1	28	178	242	30	3400	4500
	130	31	26,0	33,50	3,0	2,5	1,0	26	162	188	23	3000	4000
	130	31	22,0	33,50	3,0	2,5	1,0	41	136	158	19	2800	3800
	130	46	37,0	48,50	3,0	2,5	1,0	31	228	299	36	2800	3800
	130	46	37,0	48,50	3,0	2,5	1,0	39	200	293	36	2500	3300
65	100	23	17,5	23,00	1,5	1,5	0,6	23	81	123	15	3300	4500
	100	27	21	27	1,5	1,5	1	21	103	163	20	3400	4500
	110	34	26,5	34,00	1,5	1,5	0,6	26	136	207	25	3800	5300
	120	23	20,0	24,75	2,0	1,5	0,6	24	112	136	17	3000	4000
	120	31	27,0	32,75	2,0	1,5	0,6	28	150	200	24	3000	4000
	120	41	32,0	41,00	2,0	1,5	0,6	30	191	267	33	3000	4000
	140	33	28,0	36,00	3,0	2,5	1,0	28	185	220	27	2800	3800
	140	33	23,0	36,00	3,0	2,5	1,0	44	150	178	22	2800	3800
	140	48	39,0	51,00	3,0	2,5	1,0	33	261	331	40	2800	3800
70	110	25	19,0	25,00	1,5	1,5	0,6	24	98,1	147	18	3300	4500
	110	31	25,5	31	1,5	1,5	1	22	140	225	28	3000	4300
	120	37	29	37	2	1,5	1	28	184	279	34	3000	4000
	125	24	21,0	26,25	2,0	1,5	0,6	26	121	153	19	3000	4000
	125	31	27,0	33,25	2,0	1,5	0,6	29	155	203	25	2800	3800
	125	41	32	41	2	1,5	1	31	224	312	38	2800	4000
	150	35	30,0	38,00	3,0	2,5	1,0	30	211	251	30	2700	3500
	150	35	25,0	38,00	3,0	2,5	1,0	47	178	211	25	2700	3500
	150	51	42,0	54,00	3,0	2,5	1,0	36	293	398	47	2700	3500

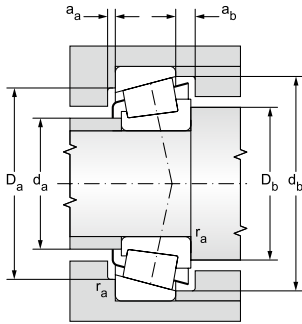

Bearing designation		Abutment and fillet dimensions									Weight	Factors		
ČSN	ISO	d	d _a	d _b	D _a	D _a	D _b	a _a	a _b	r _a	~	e	Y	Y ₀
			max	min	min	max	min	min	min	max				
mm											kg			
32011AX	T3CC055	55	61	62	80,0	83	86,0	4	5,5	1,0	0,59	0,41	1,50	0,8
33011	T2CE055		63	62	80	81	86	5	6	1	0,67	0,31	1,92	1,06
33111	T3CE055		63	62	83	86	91	5	7	1	0,89	0,29	2,06	1,13
30211A	T3DB055		63	64	87,0	91	94,0	4	4,5	1,5	0,76	0,41	1,50	0,8
32211A	T3DC055		63	64	87,0	91	95,0	4	5,5	1,5	0,92	0,41	1,50	0,8
33211	T3DE055		63	64	85	91	96	6	8	1,5	1,21	0,4	1,5	0,83
30311A	T2FB055		67	65	103,0	110	111,0	4	6,5	2,0	1,71	0,35	1,70	1,0
31311A	T7FB055		67	65	92,0	110	113,0	4	10,5	2,0	1,63	0,83	0,70	0,4
32311A	T2FD055		67	65	103,0	110	111,0	4	10,5	2,0	2,5	0,35	1,70	1,0
32012AX	T4CC060	60	66	67	85,0	88	91,0	4	5,5	1,0	0,63	0,43	1,40	0,8
33012	T2CE060		67	67	85	86	90	5	6	1	0,73	0,33	1,83	1,01
33112	T3CE060		67	67	88	91	96	5	7	1	0,89	0,4	1,51	0,83
30212A	T3EB060		69	69	95,0	101	105,5	4	4,5	1,5	0,97	0,41	1,50	0,8
32212A	T3EC060		69	69	95,0	101	104,0	4	5,5	1,5	1,27	0,41	1,50	0,8
33212	T3EE060		69	68	93	101	105	6	9	1,5	1,5	0,4	1,48	0,81
30312A	T2FB060		73	72	112,0	118	120,0	4	7,5	2,0	2,09	0,35	1,70	1,0
31312A	T7FB060		72	72	103,0	118	123,0	4	11,5	2,0	2,03	0,83	0,70	0,4
32312A	T2FD060		73	72	112,0	118	120,0	4	11,5	2,0	3,07	0,35	1,70	1,0
32312B	T5FD060		73	72	99,0	118	122,0	6	11,5	2,0	3,16	0,54	1,10	0,6
32013AX	T4CC065	65	71	72	90,0	93	97,0	4	5,5	1,0	0,68	0,46	1,30	0,7
33013	T2CE065		72	72	89	91	96	5	6	1	0,78	0,35	1,72	0,95
33113A	T3DE065		74	72	96,0	103	106,0	6	7,5	1,0	1,3	0,39	1,50	0,8
30213A	T3EB065		75	74	105,0	111	113,0	4	4,5	1,5	1,23	0,41	1,50	0,8
32213A	T3EC065		75	74	105,0	111	115,0	4	5,5	1,5	1,66	0,41	1,50	0,8
33213A	T3EE065		75	74	102,0	111	115,0	6	9,0	1,5	2,06	0,39	1,50	0,9
30313A	T2GB065		80	77	121,0	128	130,0	4	8,0	2,0	2,55	0,35	1,70	1,0
31313A	T7GB065		78	77	109,0	128	132,0	4	13,0	2,0	2,45	0,83	0,70	0,4
32313A	T2GD065		80	77	121,0	128	130,0	4	12,0	2,0	3,77	0,35	1,70	1,0
32014AX	T4CC070	70	77	77	98,0	103	105,0	5	6,0	1,5	0,89	0,44	1,40	0,8
33014	T2CE070		78	77	100	101	105	5	5,5	1	1,14	0,28	2,11	1,16
33114	T3DE070		80	79	104	111	115	6	8	1,5	1,75	0,38	1,58	0,87
30214A	T3EB070		80	79	108,0	116	118,0	4	5,0	1,5	1,37	0,42	1,40	0,8
32214A	T3EC070		80	79	108,0	116	119,0	4	6,0	1,5	1,73	0,42	1,40	0,8
33214	T3EE070		79	78	107	116	120	7	9	1,5	2,06	0,41	1,47	0,81
30314A	T2GB070		85	82	129,0	138	140,0	4	8,0	2,0	3,07	0,35	1,70	1,0
31314A	T7GB070		83	82	118,0	138	141,0	4	13,0	2,0	3,01	0,83	0,70	0,4
32314A	T2GD070		85	82	129,0	138	140,0	4	12,0	2,0	4,55	0,35	1,70	1,0



Single row tapered roller bearings in metric dimensions

d = 75 to 90 mm

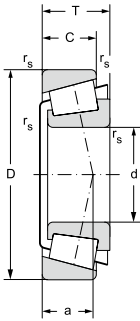

12.6.1

Main dimensions									Basic load rating		Fatigue load limit	Limiting speed for lubrication with	
d	D	B	C	T	r _{1s}	r _{2s}	r _{3s}	a	dynamic C _r	static C _{or}	P _u	grease	oil
mm									kN		kN	min ⁻¹	
75	115	25	19,0	25,00	1,5	1,5	0,6	25	104	158	19	3000	4000
	115	31	25,5	31	1,5	1,5	1	23	139	226	28	3000	4000
	125	37	29	37	2	1,5	1	30	189	293	36	2800	3800
	130	25	22,0	27,25	2,0	1,5	0,6	28	128	165	20	2800	3800
	130	31	27,0	33,25	2,0	1,5	0,6	30	162	220	27	2800	3800
	130	41	31,0	41,00	2,0	1,5	0,6	32	196	299	36	2800	3800
	160	37	31,0	40,00	3,0	2,5	1,0	32	242	287	33	2500	3300
	160	37	26	40	3	2,5	1	50	206	241	28	2200	3000
	160	55	45,0	58,00	3,0	2,5	1,0	38	341	464	54	2400	3200
	160	55	45,0	58,00	3,0	2,5	1,0	47	304	464	54	2000	2700
80	125	29	22,0	29,00	1,5	1,5	0,6	27	131	207	25	2800	3800
	125	36	29,5	36	1,5	1,5	1	26	189	315	38	2800	3600
	130	37	29,0	37,00	2,0	1,5	0,6	31	190	300	36	3200	4200
	140	26	22,0	28,25	2,5	2,0	0,6	29	144	178	21	2800	3800
	140	33	28,0	35,25	2,5	2,0	0,6	32	181	251	30	2800	3800
	140	46	35	46	2,5	2	1	35	256	394	47	2600	3400
	170	39	33	42,5	3	2,5	1	34	280	335	39	2200	3000
	170	39	27	42,5	3	2,5	1	53	224	268	31	2000	2800
	170	58	48	61,5	3	2,5	1	49	393	520	61	2200	3000
85	130	29	22,0	29,00	1,5	1,5	0,6	28	136	215	26	2800	3800
	130	36	29,5	36,00	1,5	1,5	0,6	26	195	319	38	3000	4000
	140	41	32	41	2,5	2	1	33	230	368	43	2400	3400
	150	28	24,0	30,50	2,5	2,0	0,6	30	181	207	24	2700	3500
	150	36	30,0	38,50	2,5	2,0	0,6	34	212,4	290,2	34	2400	3300
	150	36	30,0	38,50	2,5	2,0	0,6	34	237	293	34	2700	3500
	150	49	37,0	49,00	2,5	2,0	0,6	37	278	418	49	2200	3200
	180	41	34	44,5	4	3	1	36	309	373	41	2000	2800
	180	41	28	44,5	4	3	1	55	247	293	34	1900	2600
	180	60	49	63,5	4	3	1,5	51	413	570	65	2000	2800
90	140	32	24,0	32,00	2,0	1,5	0,6	30	150	228	27	2700	3500
	140	39	32,5	39,00	2,0	1,5	0,6	28	223	370	43	2800	3800
	150	45	35,0	45,00	2,5	2,0	0,6	36	265	420	48	2800	3800
	160	30	26,0	32,50	2,5	2,0	0,6	31	185	242	28	2400	3200
	160	40	34,0	42,50	2,5	2,0	0,6	37	251	355	40	2400	3200
	190	43	36	46,5	4	3	1,5	37	333	403	44	1900	2600
	190	43	30	46,5	4	3	1,5	58	270	320	36	1800	2400
	190	64	53,0	67,50	4,0	3,0	0,8	44	478	683	75	2000	2700

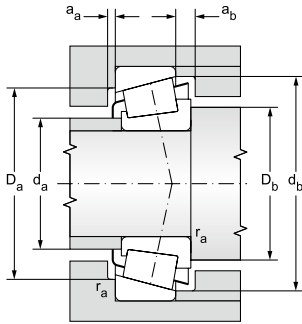

Bearing designation		Abutment and fillet dimensions									Weight	Factors		
ČSN	ISO	d	d _a	d _b	D _a	D _a	D _b	a _a	a _b	r _a	~	e	Y	Y ₀
			max	min	min	max	min	min	min	max	kg			
mm														
32015AX	T4CC075	75	82	82	103,0	108	110,0	5	6,0	1,0	0,96	0,46	1,30	0,7
33015	T2CE075		84	82	104	106	110	6	5,5	1	1,12	0,3	2,01	1,11
33115	T3DE075		84	84	109	115	120	6	8	1,5	1,74	0,4	1,51	0,83
30215A	T4DB075		85	84	113,0	121	124,0	4	5,0	1,5	1,47	0,44	1,40	0,8
32215A	T4DC075		85	84	113,0	121	121,0	4	6,0	1,5	1,82	0,44	1,40	0,8
33215A	T3EE075		85	84	111,0	121	125,0	6	10,0	1,5	2,3	0,43	1,40	0,8
30315A	T2GB075		91	87	138,0	148	149,0	4	9,0	2,0	3,72	0,35	1,70	1,0
31315	T7GB075		91	87	129	148	151	6	14	2,5	3,4	0,83	0,73	0,4
32315A	T2GD075		91	87	138,0	148	149,0	4	13,0	2,0	5,62	0,35	1,70	1,0
32315B	T5GD075		90	87	128,0	148	150,0	7	12,5	2,0	5,6	0,54	1,10	0,6
32016AX	T3CC080	80	87	87	112,0	118	120,0	6	7,0	1,0	1,32	0,42	1,40	0,8
33016	T2CE080		90	87	112	116	119	6	6,5	1	1,67	0,29	2,06	1,13
33116A	T3DE080		89	89	114,0	121	126,0	6	8,0	1,5	1,93	0,42	1,40	0,8
30216A	T3EB080		90	90	122,0	130	132,0	4	6,0	2,0	1,75	0,42	1,40	0,8
32216A	T3EC080		90	90	122,0	130	134,0	4	7,0	2,0	2,29	0,42	1,40	0,8
33216	T3EE080		89	90	122,0	130	135	7	11	2	3,01	0,41	1,45	0,8
30316	T2GB080		102	92	150	158	159	5	9,5	2,5	4,34	0,34	1,74	0,96
31316	T7GB080		97	92	136	158	159	6	15,5	2,5	4,2	0,83	0,73	0,4
32316	T5GD080		98	92	143	158	159	7	13,5	2,5	6,74	0,55	1,1	0,6
32017AX	T4CC085	85	92	92	117,0	123	125,0	6	7,0	1,0	1,41	0,44	1,40	0,7
33017A	T2CE085		92	93	117,0	123	125,0	6	6,5	1,0	1,73	0,29	2,10	1,1
33117	T3DE085		95	95	122	130	135	7	9	2	2,38	0,41	1,48	0,81
30217A	T3EB085		96	95	132,0	140	141,0	5	6,0	2,0	2,14	0,42	1,40	0,8
32217A	T3EC085		96	95	130,0	140	142,0	5	8,5	2,0	2,85	0,42	1,40	0,8
32217AJ2	T3EC085		96	95	130,0	140	142,0	5	8,5	2,0	2,85	0,42	1,40	0,8
33217A	T3EE085		96	95	128,0	140	144,0	7	12,0	2,0	3,69	0,42	1,40	0,8
30317	T2GB085		107	99	157	166	167	6	10,5	3,5	4,83	0,35	1,74	0,96
31317	T7GB085		103	99	144	166	169	6	16,5	3,5	4,9	0,83	0,73	0,4
32317	T5GD085		103	99	151	166	167	7	14,5	3,5	7,86	0,55	1,1	0,6
32018AX	T3CC090	90	99	99	124,0	131	134,0	6	8,0	1,5	1,78	0,42	1,40	0,8
33018A	T2CE090		99	99	124,0	131	135,0	6	6,5	1,5	2,25	0,27	2,20	1,2
33118A	T3DE090		101	100	130,0	140	144,0	7	10,0	2,0	3,2	0,40	1,50	0,8
30218A	T3FB090		102	100	138,0	150	150,0	5	6,0	2,0	2,71	0,42	1,40	0,8
32218A	T3FC090		102	100	138,0	150	152,0	5	8,5	2,0	3,6	0,42	1,40	0,8
30318	T2GB090		113	105	165	166	176	6	10,5	3,5	5,87	0,34	1,74	0,96
31318	T7GB090		109	105	152	176	179	6	16,5	3,5	5,4	0,83	0,73	0,4
32318A	T2GD090		109	104	157,0	176	177,0	7	14,5	2,5	8,81	0,35	1,70	0,9



Single row tapered roller bearings in metric dimensions

d = 95 to 120 mm

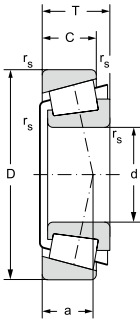

12.6.1

Main dimensions									Basic load rating		Fatigue load limit	Limiting speed for lubrication with	
d	D	B	C	T	r _{1s}	r _{2s}	r _{3s}	a	dynamic	static	P _u	grease	oil
					min	min	min		C _r	C _{or}			
mm									kN		kN	min ⁻¹	
95	145	32	24,0	32,00	2,0	1,5	0,6	31	174	280	32	2700	3500
	145	39	32,5	39,00	2,0	1,5	0,6	29	228	385	44	2700	3500
	170	32	27,0	34,50	3,0	2,5	1,0	33	214	272	30	2000	2900
	170	43	37,0	45,50	3,0	2,5	1,0	38	310	437	49	2700	3500
	200	45	38	49,5	4	3	1,5	40	350	420	45	1800	2500
	200	45	32	49,5	4	3	1,5	61	297	362	39	1700	2400
200	67	55	71,5	4	3	1,5	49	516	695	76	1900	2600	
100	150	32	24,0	32,00	2,0	1,5	0,6	33	178	261	30	2800	3800
	150	39	32,5	39,00	2,0	1,5	0,6	29	234	400	46	2500	3300
	180	34	29,0	37,00	3,0	2,5	1,0	37	266	346	38	2500	3300
	180	46	39,0	49,00	3,0	2,5	1,0	41	348	496	55	2500	3300
	215	47	39	51,5	4	3	1,5	42	411	500	58	1700	2400
	215	51	35	56,5	4	3	1,5	68	429	522	56	1500	2200
215	73	60	77,5	4	3	1,5	53	596	815	96	1700	2400	
105	160	35	26,0	35,00	2,5	2,0	0,6	35	205	337	38	2600	3400
	160	43	34,0	43,00	2,5	2,0	0,6	31	260	445	50	2400	3200
	190	36	30,0	39,00	3,0	2,5	1,0	37	293	387	42	2400	3200
	190	50	43,0	53,00	3,0	2,5	1,0	44	393	570	62	2400	3200
	225	77	63	81,5	4	3	1,5	56	638	878	100	1700	2200
110	170	38	29,0	38,00	2,5	2,0	0,6	37	246	390	43	2500	3300
	170	47	37,0	47,00	2,5	2,0	0,6	33	300	520	57	2200	3000
	200	38	32,0	41,00	3,0	2,5	1,0	39	304	402	43	1800	2500
	200	53	46,0	56,00	3,0	2,5	1,0	46	433	630	67	2200	3000
	240	50	42	54,5	4	3	1,5	45	474	583	67	1500	2000
	240	57	38	63	4	3	1,5	75	457	583	67	1400	1900
240	80	65	84,5	4	3	1,5	58	684	930	110	1500	2000	
120	180	38	29,0	38,00	2,5	2,0	0,6	40	254	430	46	2400	3200
	180	48	38	48	2,5	2	1,5	36	302	539	58	1800	2600
	215	40	34,0	43,50	3,0	2,5	1,0	43	339	452	47	1600	2200
	215	58	50,0	61,50	3,0	2,5	1,0	52	462	685	72	1600	2200
	260	55	46	59,5	4	3	1,5	48	566	710	78	1400	1900
	260	62	42	68	4	3	1,5	82	542	700	78	1300	1800
260	86	69	90,5	4	3	1,5	66	731	1045	110	1400	1900	

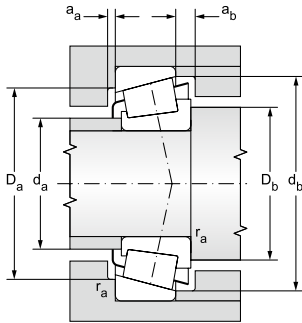

Bearing designation		Abutment and fillet dimensions									Weight	Factors		
ČSN	ISO	d	d _a	d _b	D _a	D _a	D _b	a _a	a _b	r _a	~	e	Y	Y ₀
			max	min	min	max	min	min	min	max	kg			
mm														
32019AX	T4CC095	95	105	104	130,0	136	139,0	6	8,0	1,5	1,87	0,44	1,40	0,8
33019A	T2CE095		103	104	130,0	136	139,0	6	6,5	1,5	2,34	0,28	2,10	1,2
30219A	T3FB095		107	110	148,0	158	159,0	5	7,0	2,0	3,16	0,42	1,40	0,8
32219A	T3FC095		107	110	148,0	158	161,0	5	10,0	2,0	4,32	0,42	1,40	0,8
30319	T2GB095		118	110	172	186	184	6	11,5	3,5	6,77	0,34	1,74	0,96
31319	T7GB095		114	110	158	186	187	6	17,5	3,5	6,7	0,83	0,73	0,4
32319	T2GD095		115	110	167	186	186	8	16,5	3,5	10,3	0,35	1,74	0,96
32020AX	T4CC100	100	109	109	134,0	141	144,0	6	8,0	1,5	1,94	0,46	1,30	0,7
33020A	T2CE100		109	110	134,0	141	144,0	6	6,5	1,5	2,47	0,28	2,10	1,1
30220A	T3FB100		114	112	155,0	168	168,0	5	8,0	2,0	3,81	0,42	1,40	0,8
32220A	T3FC100		114	112	155,0	168	171,0	5	10,0	2,0	5,21	0,42	1,40	0,8
30320	T2GB100		127	115	185	201	197	6	12,5	3,5	8,38	0,34	1,74	0,96
31320	T7GB100		121	115	169	201	202	7	21,5	3,5	8,8	0,83	0,73	0,4
32320	T2GD100		123	115	178	201	201	8	17,5	3,5	13,1	0,35	1,74	0,96
32021AX	T4DC105	105	116	115	143,0	150	154,0	6	9,0	2,0	2,51	0,44	1,40	0,7
33021A	T2DE105		116	116	143,0	150	153,0	6	9,0	2,0	3,06	0,28	2,10	1,2
30221A	T3FB105		120	117	163,0	178	178,0	8	9,0	2,0	4,94	0,42	1,40	0,8
32221A	T3FC105		120	117	163,0	178	178,0	6	10,0	2,0	6,38	0,42	1,40	0,8
32321	T2GD105		129	120	186	211	209	9	18,5	3,5	15,1	0,35	1,74	0,96
32022AX	T4DC110	110	120	120	152,0	160	163,0	6	9,0	2,0	3,09	0,43	1,40	0,8
33022A	T2DE110		121	121	150,0	159	160,0	6	10,0	2,0	3,87	0,29	2,10	1,2
30222A	T3FB110		125	122	171,0	188	187,0	8	9,0	2,0	5,32	0,44	1,40	0,8
32222A	T3FC110		125	122	171,0	188	190,0	6	10,0	2,0	7,56	0,44	1,40	0,8
30322	T2GB110		142	125	208	226	220	8	12,5	3,5	11,1	0,34	1,74	0,96
31322	T7GB110		135	125	191	226	224	7	25	3,5	12,3	0,83	0,73	0,4
32322	T2GD110		137	125	201	226	222	9	19,5	3,5	18,1	0,35	1,74	0,96
32024AX	T4DC120	120	130	130	162,0	170	173,0	6	9,0	2,0	3,32	0,46	1,30	0,7
33024	T2DE120		132	131	161	168	171	6	10	2	4,06	0,31	1,97	1,08
30224A	T4FB120		135	132	187,0	203	201,0	9	9,0	2,0	6,33	0,44	1,40	0,8
32224A	T4FD120		135	132	184,0	203	204,0	9	11,5	2,0	9,42	0,44	1,40	0,8
30324	T2GB120		153	135	223	246	237	7	13,5	3,5	14,3	0,34	1,74	0,96
31324	T7GB120		145	135	206	246	244	9	26	3,5	15,1	0,83	0,73	0,4
32324	T2GD120		148	135	216	246	239	9	21,5	3,5	21,1	0,35	1,74	0,96



Single row tapered roller bearings in metric dimensions

d = 130 to 200 mm

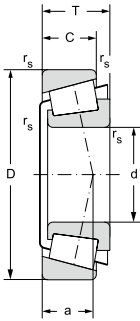

12.6.1

Main dimensions									Basic load rating		Fatigue load limit	Limiting speed for lubrication with	
d	D	B	C	T	r _{1s}	r _{2s}	r _{3s}	a	dynamic C _r	static C _{or}	P _u	grease	oil
mm									kN		kN	min ⁻¹	
130	200	45	34,0	45,00	2,5	2,0	0,6	43	330	560	59	2100	2800
	230	40	34	43,75	4	3	1,5	46	401	538	55	1500	2000
	230	64	54	67,75	4	3	1,5	56	555	845	96	1500	2000
	280	58	49	63,75	5	4	1,5	53	619	775	85	1300	1800
	280	66	44	72	5	4	1,5	87	611	788	87	1200	1700
	280	93	78	98,75	5	4	1,5	68	840	1130	130	1300	1800
140	210	45	34,0	45,00	2,5	2,0	0,6	46	335	580	60	1700	2200
	250	42	36	45,75	4	3	1,5	47	442	593	59	1400	1900
	250	68	58	71,75	4	3	1,5	60	647	1000	110	1400	1900
	300	62	53	67,75	5	4	1,5	52	664	845	90	1200	1700
	300	70	47	77	5	4	1,5	94	695	903	95	1100	1500
150	225	48	36	48	3	2,5	1,5	50	390	663	68	1400	2000
	270	45	38	49	4	3	1,5	52	492	665	65	1300	1800
	270	73	60	77	4	3	1,5	64	739	1150	130	1300	1800
	320	65	55	72	5	4	1,5	60	818	1045	110	1100	1500
	320	75	50	82	5	4	1,5	100	785	1033	110	1000	1460
	320	108	90	114	5	4	1,5	79	1330	1950	220	1100	1500
160	240	51	38	51	3	2,5	1,5	53	444	767	76	1300	1800
	290	48	40	52	4	3	1,5	51	558	760	73	1200	1600
	290	80	67	84	4	3	1,5	69	875	1395	150	1200	1600
	340	68	58	75	5	4	1,5	63	902	1160	120	1000	1400
170	260	57	43	57	3	2,5	1,5	57	548	956	93	1200	1700
	310	52	43	57	5	4	1,5	60	639	878	82	1100	1500
	310	86	71	91	5	4	1,5	74	1000	1610	170	1100	1500
180	280	64	48	64	3	2,5	1,5	60	679	1202	110	1200	1600
	320	52	43	57	5	4	1,5	62	660	928	86	1100	1400
	320	86	71	91	5	4	1,5	77	1015	1650	170	1100	1400
190	290	64	48	64	3	2,5	1,5	63	693	1231	120	1100	1500
	340	55	46	60	5	4	1,5	62	752	1043	95	1000	1300
	340	92	75	97	5	4	1,5	81	1150	1840	200	1000	1400
200	310	70	53	70	3	2,5	1,5	67	839	1449	140	1000	1400
	360	58	48	64	5	4	1,5	68	790	1090	98	900	1300
	360	98	82	104	5	4	1,5	83	1265	2035	200	950	1300

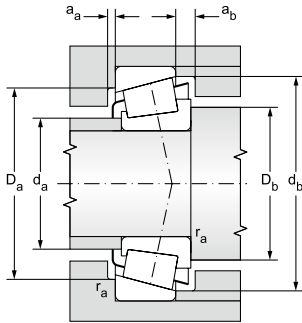

Bearing designation		Abutment and fillet dimensions									Weight	Factors		
ČSN	ISO	d	d _a	d _b	D _a	D _a	D _b	a _a	a _b	r _a	~	e	Y	Y ₀
		mm									kg			
			max	min	min	max	min	min	min	max				
32026AX	T4EC130	130	140	140	178,0	190	192,0	8	11,0	2,0	5,05	0,44	1,40	0,8
30226	T4FB130		152	146	205	216	217	7	9,5	3,5	7,2	0,44	1,38	0,76
32226	T4FD130		146	146	196	216	219	7	13,5	3,5	11,7	0,44	1,38	0,76
30326	T2GB130		164	150	239	262	255	8	14,5	4,5	17,2	0,34	1,74	0,96
31326	T7GB130		157	150	220	262	261	8	28	4,5	19,2	0,83	0,73	0,4
32326			160	147	233	262	260	10	20,5	4,5	30,2	0,34	1,75	0,96
32028AX	T4DC140	140	150	150	186,0	200	202,0	8	11,0	2,0	5,26	0,46	1,30	0,7
30228	T4FB140		164	156	221	236	236	7	9,5	3,5	8,5	0,44	1,38	0,76
32228	T4FD140		159	156	213	236	238	8	13,5	3,5	14	0,44	1,38	0,76
30328	T2GB140		176	158	256	282	283	8	14,5	4,5	20,5	0,34	1,74	0,96
31328	T7GB140		169	160	236	282	280	9	30	4,5	35,5	0,8	0,75	0,41
32030-X	T4EC150	150	164	162	202	213	216	8	12	2,5	6,31	0,46	1,31	0,72
30230	T4GB150		175	116	236	256	256	9	11	3,5	11,1	0,44	1,38	0,76
32230	T4GD150		171	166	228	256	254	8	17	3,5	18,5	0,44	1,38	0,76
30330	T2GB150		189	168	275	302	292	9	17	4,5	25,5	0,34	1,74	0,96
31330	T7GB150		181	170	253	302	300	9	32	4,5	28,5	0,83	0,73	0,4
32330			184	167	264	302	299	12	24	4,5	45	0,24	2,53	1,39
32032-X	T4EC160	160	175	174	216	228	231	8	13	2,5	7,78	0,46	1,31	0,72
30232	T4GB160		189	176	253	276	269	8	12	3,5	13,2	0,44	1,38	0,79
32232	T4GD160		183	174	243	276	274	10	17	3,5	23,8	0,44	1,38	0,76
30332	T2GB160		201	180	293	322	310	9	17	4,5	29,9	0,35	1,74	0,96
32034-X	T4EC170	170	188	184	232	248	249	10	14	2,5	10,6	0,44	1,35	0,74
30234	T4GB170		203	190	273	292	288	8	14	4,5	17	0,44	1,38	0,76
32234	T4GD170		196	190	262	292	294	10	20	4,5	29,1	0,44	1,38	0,76
32036-X	T3FD180	180	199	194	248	268	267	10	16	2,5	14,2	0,42	1,42	0,78
30236	T4GB180		211	200	281	302	297	9	14	4,5	17,9	0,44	1,38	0,76
32236	T4GD180		204	200	270	302	303	10	20	4,5	29,9	0,45	1,33	0,73
32038-X	T4FD190	190	210	204	258	278	279	10	16	2,5	14,8	0,44	2,27	1,49
30238	T4GB190		224	210	302	322	318	9	14	4,5	21	0,44	1,38	0,76
32238	T4GD190		216	207	290	322	323	10	22	4,5	36,7	0,44	1,38	0,76
32040-X	T4FD200	200	222	214	277	298	297	11	17	2,5	18,9	0,43	1,39	0,77
30240A	T4GB200		237	218	315	342	336	9	16	3	25	0,43	1,40	0,8
32240	T3GD200		231	220	305	342	340	11	22	4,5	43,7	0,41	1,48	0,81



Single row tapered roller bearings in metric dimensions

d = 220 to 320 mm

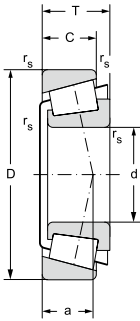

12.6.1

Main dimensions										Basic load rating		Fatigue load limit	Limiting speed for lubrication with	
d	D	B	C	T	r _{1s}	r _{2s}	r _{3s}	a	dynamic	static	P _u	grease	oil	
					min	min	min		C _r	C _{or}				
mm										kN		kN	min ⁻¹	
220	340	76	57	76	4	3	1,5	73	963	1736	160	950	1300	
	400	65	54	72	5	4	1,5	75	983	1367	120	850	1100	
	400	108	90	114	5	4	1,5	94	1575	2625	250	850	1100	
240	360	76	57	76	4	3	1,5	79	973	1804	160	850	1200	
	440	120	100	127	5	4	1,5	105	1825	3250	300	750	1000	
260	400	87	65	87	5	4	1,5	86	1191	2255	190	800	1100	
	480	130	106	137	6	5	1,5	113	2220	3725	340	670	950	
280	420	87	65	87	5	4	1,5	91	843	1782	150	710	1000	
300	460	100	74	100	5	4	1,5	98	1604	3066	250	670	900	
320	480	100	74	100	5	4	1,5	104	1615	3099	250	630	850	

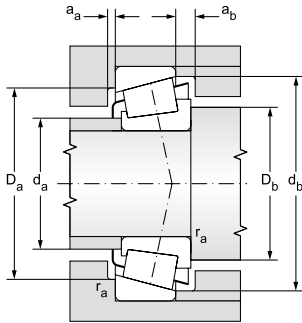

Bearing designation		Abutment and fillet dimensions									Weight	Factors		
ČSN	ISO	d	d_a	d_b	D_a	D_a	D_b	a_a	a_b	r_a	~	e	Y	Y ₀
			max	min	min	max	min	min	min	max	kg			
mm														
32044-X	T4FD220	220	244	236	303	326	326	12	19	3,5	24,4	0,43	1,39	0,77
30244	T4GB220		2559	242	350	382	371	10	18	4,5	34,6	0,42	1,43	0,79
32244			258	242	340	382	383	13	24	4,5	60,2	0,44	1,36	0,75
32048-X	T4FD240	240	262	256	321	346	346	12	19	3,5	25,1	0,46	1,31	0,72
32248			290	262	374	422	415	13	27	4,5	78,6	0,45	1,34	0,73
32052-X	T4FC260	260	287	282	357	382	383	13	22	4,5	38,1	0,43	1,38	0,76
32252			303	268	400	458	458	16	31	5,5	106	0,32	1,88	1,04
32056-X	T4FC280	280	305	302	384	402	402	14	22	4,5	66,3	0,46	1,31	0,72
32060-X	T4GD300	300	330	322	408	442	440	15	26	4,5	57,2	0,43	1,38	0,76
32064-X	T4GD320	320	350	342	430	462	460	15	26	4,5	59,4	0,46	1,31	0,72



Single row tapered roller bearings in inch dimensions $d = 15.875$ to 146.05 mm

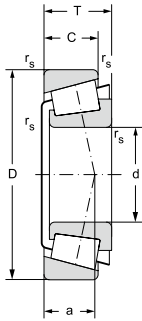

12.6.2

Main dimensions											Basic load rating		Fatigue load limit	Limiting speed for lubrication with		Bearing designation
d	D	D ₁	B	C	C ₁	T	T ₁	r _{1s}	r _{2s}	s	dynamic	static	P _u	grease	oil	Cone/Cup
								min	min		C _r	C _{or}				
mm											kN		kN	min ⁻¹		
15,875	42,863		14,3	9,53		14,3		1,50	1,5	0,6	17,3	18,6	2,3	9500	14000	K-11590/ K-11520
16	47		21,0	16,00		21,0		1,00	2	5,9	36,9	40,6	5	8400	11000	K-HM81649/ K-HM81610
17,462	39,878		14,6	10,67		13,8		1,30	1,3	5,2	21,1	21,5	2,6	10000	13000	K-LM11749/ K-HM11710
19,05	45,237		16,6	12,07		15,5		1,30	1,3	5,5	25,6	26,6	3,2	8900	12000	K-LM11949/ K-LM11910
19,05	49,225		19,1	14,29		18,0		1,30	1,3	7,1	37,7	37,7	4,6	8900	12000	09067/ 09195
19,05	49,225		19,1	17,46		21,2		1,30	1,5	8,8	37,7	37,7	4,6	8900	12000	09067/ 09196
21,986	45,237		16,6	12,07		15,5		1,20	1,2	5,4	28,7	29,9	3,6	8400	11000	K-LM12749/ K-LM12710
22	45	51,5	16,6	12,07	3,0	15,5	6,4	1,20	1,2	5,4	28,7	29,9	3,6	8400	11000	K-LM12749/ K-LM12712B
25,4	50,292		14,7	10,67		14,2		1,30	1,3	3,3	24,6	28,7	3,5	7500	10000	K-L44643/ K-L44610
25,4	57,15		19,4	14,73		19,4		1,50	1,5	3	44,9	52,9	6,5	6400	8600	M84548/ 84510
25,4	59,93		23,1	18,29		23,4		0,80	1,57	5	44,7	66,8	8,1	5600	7500	K-M84249/ K-M84210
25,4	62		20,6	15,88		19,1		0,80	1,3	4,8	44,6	50,7	6,2	6400	8600	15101/ 15245
25,4	63,5		20,6	15,88		20,6		0,80	1,5	6,2	44,6	50,7	6,2	6400	8600	15101/ 15250X
26,988	50,292		14,7	10,67		14,2		3,56	1,3	3,3	24,6	28,7	3,5	7500	10000	K-L44649/ K-L44610
26,988	62		20,6	14,29		19,1		0,80	1,3	5,5	44,6	50,7	6,2	6400	8600	15106/ 15245
28,575	68,262		22,2	17,46		22,2		0,80	1,5	5,2	51	61,1	7,5	6000	8000	02474/ 0220
28,575	73,025		22,2	17,46		22,2		0,80	3,3	3,8	55	65,7	8	5500	7400	02872/ 02820
29	50,292		14,7	10,67		14,2		3,60	1,2	3,3	25,6	33,5	4,1	7100	9400	K-L45449/ K-L45410

d = 15.875 to 29 mm

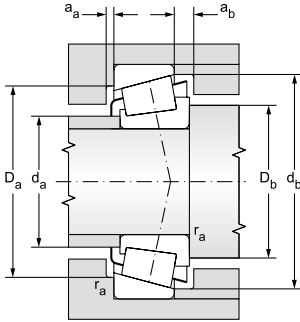

Abutment and fillet dimensions										Weight	Dimension deviations						Factors		
d_a	d_b	D_a	D_d	D_d	a_a	a_b	r_a	r_b	r_b	~	Δd_{mp}		ΔD_{mp}		ΔT_s		e	γ	γ_o
max	min	min	max	min	min	min	max	max			max	min	max	min	max	min			
mm										kg	μm								
22,5	24,50	34,5	35	39,5	2,0	4,50	1,5	1,5	1,5	0,063	+13	0	+25	0	+200	0	0,7	0,9	0,5
23,0	22,00	36	39	43	2,0	4,00	1,0	1,5	1,5	0,20	0,00	-13	0	-25	+200	0	0,55	1,1	0,6
23,0	24,00	33,5	35	37	2,0	3,00	1,0	1,0	1,0	0,19	+13	0	+15	0	+200	0	0,29	2,1	1,1
25,0	25,50	38	38,5	41	3,0	3,00	1,0	1,0	1,0	0,12	+20	0	+25	0	+356	0	0,3	2	1,1
24,0	25,50	42	42,5	44,5	4,0	4,50	1,3	1,3	1,3	0,17	+13	0	+25	0	+203	0	0,27	2,26	1,2
24,0	25,50	41,5	42	44,5	1,0	4,50	1,3	1,5	1,5	0,19	+13	0	+25	0	+203	0	0,27	2,26	1,2
26,0	27,50	38	38,5	42,5	3,0	3,00	1,2	1,2	1,2	0,12	+13	0	0	+15	+200	0	0,31	1,96	1,1
26,0	27,50	-	-	46	1,2	3,50	1,3	-	-	0,13	-13,00	0	0	-15	+200	0	0,31	1,96	1,1
33,0	32,00	43,5	43,5	47	2,0	3,50	1,0	1,0	1,0	0,13	+13	0	+25	0	+200	0	0,37	1,6	0,9
33,0	36,00	48,5	49	54	2,5	5,00	1,5	1,5	1,5	0,23	+13	0	+25	0	+203	0	0,55	1,1	0,6
33,0	32,00	46	53	56	3,0	4,50	0,6	1,0	1,0	0,33	+13	0	+25	0	+200	0	0,55	1,1	0,6
31,5	32,50	55	56	58	5,0	5,00	0,8	1,3	1,3	0,29	+13	0	+25	0	+203	0	0,35	1,71	0,9
31,5	32,50	55	56	59	3,0	5,00	0,8	1,5	1,5	0,32	+13	0	+25	0	+203	0	0,35	1,71	0,9
33,0	38,00	43,5	45	47	3,0	3,50	3,0	1,0	1,0	0,12	+20	0	+25	0	+356	0	0,37	1,6	0,9
33,0	33,50	55	56	58	5,0	5,00	0,8	1,3	1,3	0,28	+13	0	+25	0	+203	0	0,35	1,71	0,9
36,0	36,50	59	60	63	3,0	5,50	0,8	1,5	1,5	0,40	+13	0	+25	0	+203	0	0,42	1,44	0,8
37,0	37,50	62	63	68	3,0	5,00	0,8	3,3	3,3	1,04	+13	0	+25	0	+203	0	0,45	1,32	0,7
34,0	40,00	43,5	45	47	3,0	3,50	3,0	1,0	1,0	0,11	+13	0	+15	0	+200	0	0,37	1,6	0,9



Single row tapered roller bearings in inch dimensions

d = 30 to 36.512 mm

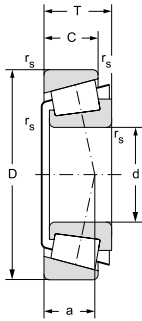

12.6.2

Main dimensions											Basic load rating		Fatigue load limit	Limiting speed for lubrication with		Bearing designation
d	D	D ₁	B	C	C ₁	T	T ₁	r _{1s}	r _{2s}	s	dynamic	static	P _u	grease	oil	Cone/Cup
								min	min		C _r	C _{or}		min ⁻¹		
mm											kN		kN	min ⁻¹		
30	62	68,5	18,1 15,54	3,6	17,3	5,3	1,00	1,5	2,8	44,7	44,7	5,5	6700	8900	K-JXC25640CB/ K-JXC25640D	
30,162	64,292		21,4 16,67		21,4		1,57	1,57	2,9	44,7	59,6	7,3	5600	7500	K-M86649/ K-M86610	
30,213	62		20,6 14,29		19,1		3,50	1,3	5,5	44,6	50,7	6,2	6400	8600	15118/ 15245	
31,75	59,131		16,8 11,81		15,9		4,75	1,3	2,7	31,6	38,3	4,7	6700	8900	K-LM67048/ K-LM67010	
31,75	62		19,1 14,29		18,2		4,75	1,3	4,6	47,3	58,4	7,1	6300	8400	K-15123/ K-15245	
31,75	62		20,6 14,29		19,1		0,80	1,3	5,5	44,6	50,7	6,2	6400	8600	151126/ 15245	
31,75	63,5		19,1 15,88		20,6		0,80	1,5	6,2	44,6	50,7	6,2	6400	8600	15123/ 15250X	
31,75	69,012		19,6 15,88		19,8		3,50	3,3	4,1	46,1	55	6,7	5900	7800	14125A/ 14274	
33,338	68,262		22,2 17,46		22,2		0,80	1,5	2,6	56,1	71,1	8,7	6000	7900	M88048/ 88010	
34,925	65,088		18,3 13,97		18,0		4,75	1,3	3,7	43	53,1	6,5	5600	7500	K-LM48548/ K-LM48510	
34,925	69,012		19,6 15,88		19,8		3,50	3,3	4,2	46,1	55	6,7	5900	7800	14138A/ 14274	
34,925	72,233		25,4 19,84		25,4		2,30	2,3	4,1	66,9	87,4	11	5700	7600	HM88649/ 88610	
34,925	73,025		24,6 19,05		23,8		1,50	2,3	8,1	72,2	87,3	11	5600	7400	25877/ 25820	
34,925	76,2		28,6 23,81		29,4		1,50	3,3	8,9	80,9	97,4	12	5400	7200	31594/ 31520	
34,988	61,973		17,0 13,60		16,7		0,80	1,5	1,8	39,4	52,4	6,4	5600	7500	LM78349/ 78310A	
35	59,975		18,4 11,94		15,9		2,50	1,3	2,4	36	48,6	5,9	6400	8500	F15036/ JL68111Z	
35	60		16,8 11,94		15,9		4,75	1,3	2,3	31,6	42,2	5,1	6300	8400	K-L68149/ K-L68111	
36,487	76,2		25,7 19,05		23,8		1,50	3,3	7,6	81,1	105	13	5000	6700	2780/ 2720	
36,512	76,2		28,6 23,02		29,4		3,50	3,3	6	79,5	107	13	5400	7200	HM89449/ 89410	

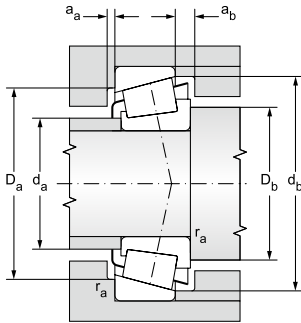

Abutment and fillet dimensions										Weight	Dimension deviations						Factors		
d_a	d_b	D_a	D_d	D_d	a_a	a_b	r_a	r_b		~	Δd_{mp}		ΔD_{mp}		ΔT_s		e	γ	γ_o
max	min	min	max	min	min	min	max	max			max	min	max	min	max	min			
mm										kg	μm								
34,5	37,00	-	-	59	1,2	1,70	1,5	-	0,27	0,00	-12	+20	0	+200	0	0,37	1,6	0,9	
38,0	38,00	51	56,5	60	3,0	4,50	1,0	1,0	0,34	+13	0	+25	0	+200	0	0,55	1,1	0,6	
35,5	41,50	55	56	58	5,0	5,00	3,5	1,3	0,26	+13	0	+25	0	+203	0	0,35	1,71	0,9	
38,0	44,50	51	52	55	3,0	4,00	3,0	1,0	0,18	+13	0	+25	0	+356	0	0,41	1,5	0,8	
38,0	43,50	54	55	58	4,0	3,50	3,0	1,0	0,25	+13	0	+25	0	+203	0	0,35	1,7	0,9	
36,5	37,00	55	56	58	5,0	5,00	0,8	1,3	0,25	+13	0	+25	0	+203	0	0,35	1,71	0,9	
31,5	32,50	55	56	59	3,0	5,00	0,8	1,5	0,32	+13	0	+25	0	+203	0	0,35	1,71	0,9	
40,0	46,00	60	61	63	3,0	4,50	3,5	1,3	0,32	+13	0	+25	0	+203	0	0,38	1,57	0,9	
41,0	42,50	58	59	65	3,0	4,00	0,8	1,5	0,37	+13	0	+25	0	+203	0	0,55	1,1	0,6	
42,0	47,00	57	58	61	3,0	4,00	3,0	1,0	0,24	+20	0	+25	0	+356	0	0,38	1,6	0,9	
40,0	46,00	60	61,5	63	3,0	4,50	3,5	1,3	0,32	+13	0	+25	0	+203	0	0,38	1,57	0,9	
42,5	48,50	60	61,5	69	4,0	5,50	2,3	2,3	0,50	+13	0	+25	0	+203	0	0,55	1,1	0,6	
40,5	43,00	64	65,5	68	4,5	5,50	1,5	2,3	0,46	+13	0	+25	0	+203	0	0,29	2,07	1,1	
43,5	46,00	64	65,5	72	2,5	6,00	1,5	3,3	0,62	+13	0	+25	0	+203	0	0,4	1,49	0,8	
40,0	46,00	54	55,5	59	3,0	4,00		1,5	0,19	0,00	-13	0	-25	+203	0	0,44	1,35	0,8	
45,5	39,00	53	54,5	56	4,0	3,00	2,5	1,3	0,19	+13	0	+25	0	+203	0	0,42	1,44	0,8	
40,0	46,00	52	54	56	3,0	3,50	3,0	1,0	0,18	0,00	-20	0	-25	+356	0	0,42	1,4	0,8	
42,5	44,50	66	67,5	70	5,0	5,00	1,5	3,3	0,52	+13	0	+25	0	+203	0	0,3	1,98	1,1	
44,5	54,00	62	63,5	73	3,0	5,50	3,5	3,3	0,62	+13	0	+25	0	+203	0	0,55	1,1	0,6	



Single row tapered roller bearings in inch dimensions

d = 38 to 42.875 mm

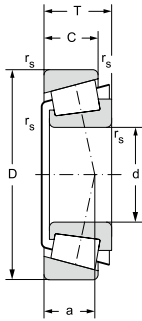

12.6.2

Main dimensions										Basic load rating		Fatigue load limit	Limiting speed for lubrication with		Bearing designation	
d	D	D ₁	B	C	C ₁	T	T ₁	r _{1s}	r _{2s}	s	dynamic	static	P _u	grease	oil	Cone/Cup
								min	min		C _r	C _{or}				
mm										kN		kN	min ⁻¹			
38	63		17,0	13,50		17,0		1,50	1,5	2,4	42,2	55,2	6,7	6700	8900	K-JL69349/ K-JL69310
38,1	65,088		18,3	13,97		18,0		2,30	1,1	4,7	49,2	60,7	7,4	5600	7500	K-LM29749/ K-LM29710
38,1	65,088		18,3	15,75		19,8		2,30	1,3	5,6	42,9	56,5	6,9	5800	7800	LM29749/ 29711
38,1	69,012		19,1	15,08		19,1		3,50	2,3	3,3	49,2	62	7,6	5600	7500	13685/ 13621
38,1	76,2		25,7	19,05		23,8		3,50	3,3	7,6	81,1	105	13	5000	6700	2788/ 2720
38,1	82,55		28,6	23,02		29,4		0,80	3,3	4,9	87,3	117	14	4900	6600	HM801346/ 801310
38,1	88,5		29,1	22,23		27,0		3,50	1,5	9,1	98,2	112	14	4900	6500	418/ 414
39,688	80,167		30,4	23,81		29,4		0,80	3,2	11,3	81	104	13	4200	5600	K-3386/ K-3320
40	80		22,4	17,83		21,0		0,80	1,3	5,7	70,8	73,6	9	4700	6300	K-344A/ K-332
40,1	67,975		18,0	13,50		17,5		3,60	1,5	3,6	47,3	59,6	7,3	5300	7100	K-LM300849/ K-LM300811
40,988	67,975		18,0	13,50		17,5		0,80	1,5	3,6	46,1	63,5	7,7	5400	7200	LM300849/ 300811
41,275	73,025		17,5	12,70		16,7		3,50	1,5	2,5	45,9	55,8	6,8	5200	6900	18590/ 18520
41,275	73,431		19,8	14,73		19,6		3,50	0,8	3,4	57,8	73	8,9	5200	7000	LM501349/ 501310
41,275	73,431		19,8	16,60		21,4		3,50	0,8	4,5	57,8	73	8,9	5200	7000	LM501349/ 501314
41,275	76,2		23,0	17,46		22,2		3,50	0,8	4,7	66,3	83,3	10	5200	6900	24780/ 24720
41,275	87,312		30,9	23,81		30,2		1,50	3,3	10,5	95,8	120	15	4600	6200	3585/ 3525
41,275	88,9		29,4	23,02		30,2		3,50	3,3	4,5	99,6	125	15	4600	6100	HM803146/ 803110
42,875	82,931		25,4	19,05		23,8		3,50	0,8	6,2	77,2	100	12	4800	6300	25577/ 25520
42,875	82,931		25,4	22,23		27,0		3,50	2,3	8	77,2	100	12	4800	6300	25577/ 25523
42,875	83,058		25,4	19,05		23,8		3,50	3,3	6,2	77,2	100	12	4800	6300	25577/ 25521

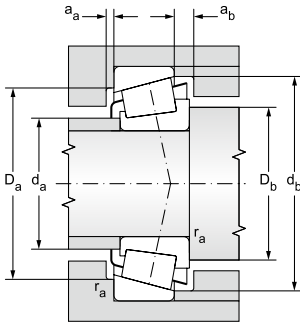

Abutment and fillet dimensions										Weight	Dimension deviations						Factors		
da	db	Da	Dd	Dd	aa	ab	ra	rb	~	Δdmp		ΔDmp		ΔTs		e	Y	Yo	
max	min	min	max	min	min	min	max	max		max	min	max	min	max	min				
mm										kg	μm								
41,0	49,00	56,5	57	60	1,5	3,50	1,5	1,5	0,20	+13	0	+25	0	+200	0	0,42	1,44	0,8	
42,5	46,00	58	60	62	4,0	4,00	2,3	1,3	0,24	+13	0	+25	0	+200	0	0,33	1,8	1,0	
42,5	46,00	58	59,5	62	1,5	4,50	2,3	1,3	0,24	+13	0	+25	0	+203	0	0,33	1,8	1,0	
43,0	49,50	61	62,5	65	2,5	4,00	3,5	2,3	0,28	+13	0	+25	0	+203	0	0,4	1,49	0,8	
43,5	50,00	66	67,5	70	5,0	5,00	3,5	3,3	0,49	+13	0	+25	0	+203	0	0,3	1,98	1,1	
49,1	51,00	68	69,5	78	3,0	6,00	0,8	3,3	0,76	+13	0	+25	0	+203	0	0,55	1,1	0,6	
44,5	51,00	77	78,5	80	5,0	6,00	3,5	1,5	0,82	+13	0	+25	0	+203	0	0,26	2,28	1,3	
48,0	47,00	68	70	75	3,0	4,00	0,6	3,0	0,70	+13	0	+25	0	+200	0	0,27	2,2	1,2	
48,0	47,00	68	73	75	3,0	4,00	0,6	1,0	0,51	+13	0	+25	0	+203	0	0,27	2,2	1,2	
45,0	52,00	58	61	63	4,0	4,00	0,6	1,5	0,23	+13	0	+25	0	+200	0	0,35	1,7	0,9	
45,0	52,00	61	62,5	65	3,5	5,00	**	1,5	0,23	0,00	-13	0	-25	+203	0	0,35	1,72	0,9	
46,0	53,00	66	67,5	69	4,0	5,50	3,5	1,5	0,27	+13	0	+25	0	+203	0	0,35	1,71	0,9	
46,5	53,00	67	68,5	70	3,5	5,50	3,5	0,8	0,32	+13	0	+25	0	+203	0	0,4	1,5	0,8	
46,5	53,00	66	67,5	70	1,5	5,50	3,5	0,8	0,34	+13	0	+25	0	+203	0	0,4	1,5	0,8	
47,0	54,00	68	69,5	72	3,5	5,50	3,5	0,8	0,41	+13	0	+25	0	+203	0	0,39	1,53	0,9	
48,0	50,00	75	76,5	81	3,5	6,50	1,5	3,3	0,82	+13	0	+25	0	+203	0	0,31	1,96	1,1	
53,0	60,00	74	75,5	85	4,0	7,50	3,5	3,3	0,89	+13	0	+25	0	+203	0	0,55	1,1	0,6	
49,0	55,00	74	75,5	77	4,5	5,50	3,5	0,8	0,58	+13	0	+25	0	+203	0	0,33	1,79	1,0	
51,0	58,00	72	73,5	77	1,0	5,50	3,5	2,3	0,58	+13	0	+25	0	+203	0	0,33	1,79	1,0	
51,0	58,00	72	73,5	77	1,0	5,50	3,5	2,3	0,58	+13	0	+25	0	+203	0	0,33	1,79	1,0	



Single row tapered roller bearings in inch dimensions

d = 44.45 to 50 mm

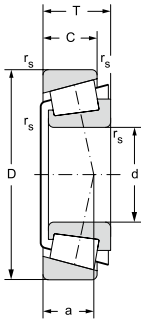

12.6.2

Main dimensions											Basic load rating		Fatigue load limit	Limiting speed for lubrication with		Bearing designation
d	D	D ₁	B	C	C ₁	T	T ₁	r _{1s}	r _{2s}	s	dynamic	static	P _u	grease	oil	Cone/Cup
								min	min		C _r	C _{or}				
mm											kN		kN	min ⁻¹		
44,45	83,058		25,4	19,05		23,8		3,56	3,2	6,2	59,6	87,4	11	4200	5600	K-25580/ K-25521
44,45	83,058		25,4	19,11		23,9		3,50	2	6,2	77,2	100	12	4800	6300	2580/ 25522
44,45	88,9		29,4	23,02		30,2		3,60	3,2	4,5	99,6	125	15	4600	6100	HM803149/ 803010
44,45	93,264		30,3	23,81		30,2		3,50	3,3	9	103	137	17	4200	5500	3782/ 3720
44,45	95,25		28,6	22,23		31,0		3,50	0,8	-0,7	99,7	120	15	3700	5100	HM903249/ 903210
44,45	104,775		36,5	28,58		36,5		3,50	3,3	7,5	141	195	24	3800	5100	HM807040/ 807010
45,23	79,985		20,6	15,08		19,8		2,00	1,3	3,3	62	78,5	9,6	4800	6400	17887/ 17831
45,242	73,431		19,8	15,75		19,6		3,50	0,8	4,9	55,6	78,1	9,5	5100	6700	LM102949/ 102910
45,242	77,788		19,8	15,08		19,8		3,60	0,8	2,2	57,1	73,5	9	4900	6500	LM603049/ 603011
45,242	77,788		19,8	15,80		19,8		1,00	1	1,9	59,6	77,9	9,5	4900	6500	LM603049/ LM603011
45,242	77,788		19,8	16,67		21,4		3,60	0,8	3,2	57,1	73,5	9	4900	6500	LM603049/ 603012
45,618	82,931		25,4	22,23		27,0		3,50	2,3	7,9	77,2	100	12	4800	6300	25590/ 25523
45,987	74,976		18,0	14,00		18,0		2,30	1,5	1,9	52,6	74,6	9,1	5000	6600	LM503349/ 503310
46,038	79,375		17,5	13,50		17,5		2,80	1,5	1,7	47,1	59,1	7,2	4800	6400	18690/ 18620
50	82		21,5	17,00		21,5		3,00	0,5	5,4	75,2	104	13	4500	6000	K-JLM104948/ K-JLM104910

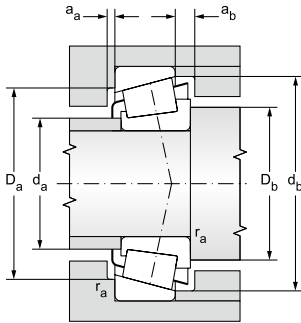

Abutment and fillet dimensions										Weight	Dimension deviations						Factors		
d_a	d_b	D_a	D_d	D_d	d_a	d_b	r_a	r_b		~	Δd_{mp}		ΔD_{mp}		ΔT_s		e	γ	γ_o
max	min	min	max	min	min	min	max	max			max	min	max	min	max	min			
mm										kg	μm								
53,0	56,50	71	74	73	5,0	4,50	3,0	3,0	0,54	+13	0	+25	0	+200	0	0,33	1,8	1,0	
50,0	57,00	73	74,5	77	4,5	5,50	3,5	2,0	0,56	+13	0	+25	0	+203	0	0,33	1,79	1,0	
53,4	62,00	74	75,5	85	7,5	4,00	3,6	3,2	0,84	+13	0	+25	0	+203	0	0,55	1,1	0,6	
52,0	58,00	82	83,5	88	3,5	7,00	3,5	3,3	0,95	+13	0	+25	0	+203	0	0,34	1,77	1,0	
54,0	65,00	81	82,5	91	2,0	7,00	3,5	0,8	1,00	+13	0	+25	0	+203	0	0,74	0,81	0,5	
59,0	66,00	89	90,5	100	4,0	7,00	3,5	3,3	1,62	+13	0	+25	0	+203	0	0,49	1,23	0,7	
51,0	56,00	71	72,5	74	3,5	5,00	2,0	1,3	0,40	+13	0	+25	0	+203	0	0,37	1,6	0,9	
50,0	56,00	68	69,5	70	3,0	4,50	3,5	0,8	0,31	+13	0	+25	0	+203	0	0,31	1,97	1,1	
50,0	57,00	71	72,5	74	5,0	3,50	3,6	0,8	0,36	+13	0	+25	0	+203	0	0,43	1,41	0,8	
50,0	57,00	71	72	74	4,5	5,50	1,0	1,0	0,38	+13	0	+25	0	+100	0	0,43	1,41	0,8	
50,0	57,00	71	72,5	74	5,0	2,00	3,6	0,8	0,37	+13	0	+25	0	+203	0	0,43	1,41	0,8	
51,0	58,00	72	73,5	77	1,0	5,50	3,5	2,3	0,58	+13	0	+25	0	+203	0	0,33	1,79	1,0	
51,0	55,00	67	68,5	71	3,5	5,00	2,3	1,5	0,30	0,00	-13	0	-25	+203	0	0,4	1,49	0,8	
51,0	56,00	71	72,5	74	3,5	5,00	2,8	1,5	0,33	+13	0	+25	0	+203	0	0,37	1,6	0,9	
55,0	60,00	76	77	78	4,0	4,50	3,0	0,5	0,41	-12,00	0	-18	0	+100	0	0,31	1,097	1,1	



Single row tapered roller bearings in inch dimensions

d = 50.8 to 65 mm

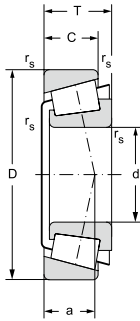

12.6.2

Main dimensions										Basic load rating		Fatigue load limit	Limiting speed for lubrication with		Bearing designation	
d	D	D ₁	B	C	C ₁	T	T ₁	r _{1s}	r _{2s}	s	dynamic	static	P _u	grease	oil	Cone/Cup
								min	min		C _r	C _{or}				
mm										kN		kN	min ⁻¹			
50,8	82	22,2	17,00	22,0	3,50	0,5	5,9				61,2	84,3	10	4500	6000	LM104949/ 104910
50,8	82,55	22,2	16,51	21,6	3,50	1,3	5,7				61,2	84,3	10	4500	6000	LM104949/ 104911
50,8	85	17,5	13,50	17,5	3,50	1,5	0				49,7	65,5	8	4400	5900	18790/ 18720
50,8	88,9	22,2	16,51	20,6	3,50	1,3	3,8				74,3	87,3	11	4400	5800	368A/ 362A
50,8	90	22,2	15,88	20,0	3,50	2	3,3				74,3	87,3	11	4400	5800	368A/ 362X
50,8	92,075	25,4	19,85	24,6	3,50	0,8	4,3				84,8	119	15	4200	5600	28580/ 28521
50,8	93,264	30,3	23,81	30,2	3,50	3,3	9				103	137	17	4200	5500	3780/ 3720
50,8	101,6	36,1	29,99	34,9	0,80	3,2	11,8				123	162	20	3200	4200	K-529/ K-522
50,8	104,775	36,5	28,58	36,5	3,50	3,3	7,5				141	195	24	3800	5100	HM807046/ 807010
52,388	92,075	25,4	19,85	24,6	3,50	0,8	4,3				84,8	119	15	4200	5600	28584/ 28521
52,388	93,264	30,3	23,81	30,2	2,30	3,3	9				95,8	120	15	4600	6200	3767/ 3720
55	90	23,0	18,50	23,0	1,50	0,5	3				81,4	115	14	4200	5500	JLM506849/ 506810
57,15	96,838	21,9	15,88	21,0	2,30	0,8	2,6				80,4	101	12	3900	5200	387/ 382A
57,15	96,838	21,9	20,27	25,4	2,30	2,3	5,1				80,4	101	12	3900	5200	387/ 382S
57,15	98,425	21,9	17,83	21,0	2,40	0,8	1,6				80,4	101	12	3900	5200	387/ 382A
57,15	104,775	29,3	24,61	30,2	2,30	3,3	7,4				109	144	18	3700	4900	462/ 453X
57,15	127	44,5	34,93	44,5	3,50	3,3	9,2				228	276	34	3000	4000	K-65225/ K-65500
63,5	107,95	25,4	19,05	25,4	3,50	3,3	0,8				92,8	143	17	3400	4500	29585/ 29520
63,5	112,712	30,0	23,81	30,2	3,50	3,3	4,8				111	164	20	3400	4500	3982/ 3920
65	110	28,0	22,50	28,0	3,00	2,5	3,9				133	188	23	3300	4500	K-JM511946/ K-JM511910

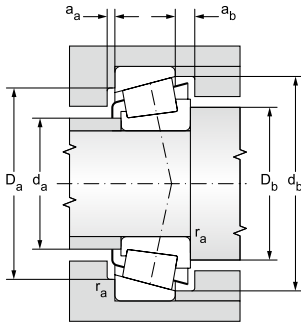

Abutment and fillet dimensions										Weight	Dimension deviations						Factors		
da	db	Da	Dd	Dd	aa	ab	ra	rb		~	Δdmp		ΔDmp		ΔTs		e	Y	Yo
max	min	min	max	min	min	min	max	max			max	min	max	min	max	min			
mm										kg	μm								
55,0	62,00	76	77,5	78	5,5	4,50	3,5	0,5	0,42	+13	0	+25	0	+203	0	0,31	1,97	1,1	
55,0	62,00	75	76,5	78	4,5	5,50	3,5	1,3	0,42	+13	0	+25	0	+203	0	0,31	1,97	1,1	
56,0	62,00	77	78,5	80	3,5	5,00	3,5	1,5	0,36	+13	0	+25	0	+203	0	0,41	1,48	0,8	
56,0	62,00	81	82,5	84	5,0	5,50	3,5	1,3	0,50	+13	0	+25	0	+203	0	0,32	1,88	1,0	
56,0	62,00	81	82,5	84	5,0	5,50	3,5	2,0	0,51	+13	0	+25	0	+203	0	0,32	1,88	1,0	
57,0	63,00	83	84,5	87	3,5	5,00	3,5	0,8	0,69	+13	0	+25	0	+203	0	0,38	1,59	0,9	
58,0	64,00	82	83,5	88	3,5	7,00	3,5	3,3	0,84	+13	0	+25	0	+203	0	0,34	1,77	1,0	
61,0	63,50	87	89,5	94	6,0	7,50	0,6	3,0	1,22	+13	0	+25	0	+200	0	0,28	2,1	1,2	
63,0	70,00	89	90,5	100	4,0	7,00	3,5	3,3	1,49	+13	0	+25	0	+203	0	0,49	1,23	0,7	
58,0	65,00	83	84,5	87	3,5	5,00	3,5	0,8	0,66	+13	0	+25	0	+203	0	0,38	1,59	0,9	
59,0	63,00	82	83,5	88	3,5	7,00	2,3	3,3	0,81	+13	0	+25	0	+203	0	0,34	1,77	1,0	
61,0	63,00	82	83,5	86	3,5	5,00	1,5	0,5	0,55	0,00	-15	0	-18	+203	0	0,4	1,49	0,8	
62,0	66,00	89	90,5	92	5,5	6,00	2,3	0,8	0,58	+13	0	+25	0	+203	0	0,35	1,69	0,9	
62,0	69,00	87	88,5	91	5,5	6,00	3,5	2,3	0,64	+13	0	+25	0	+203	0	0,35	1,69	0,9	
62,0	66,00	89	90,5	92	6,0	5,00	2,4	0,8	0,61	+13	0	+25	0	+203	0	0,35	1,69	0,9	
63,0	67,00	92	93,5	98	3,0	5,50	2,3	3,3	1,04	+13	0	+25	0	+203	0	0,34	1,79	1,0	
71,0	80,00	104	107	119	10,0	10,00	3,5	3,3	2,79	+13	0	+25	0	+200	0	0,49	1,2	0,7	
71,0	77,00	96	97,5	103	3,0	6,00	3,5	3,3	0,91	+13	0	+25	0	+203	0	0,46	1,31	0,7	
71,0	77,00	99	100,5	106	3,5	6,50	3,5	3,3	1,22	+13	0	+25	0	+203	0	0,4	1,49	0,8	
71,0	77,00	93	96	101	9,5	9,50	3,0	2,5	1,05	-15,00	0	-15	0	+200	0	0,39	1,5	0,9	



Single row tapered roller bearings in inch dimensions

d = 66.675 to 89.974 mm

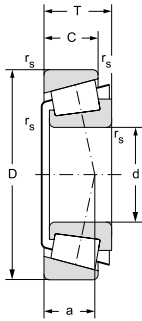

12.6.2

Main dimensions											Basic load rating		Fatigue load limit	Limiting speed for lubrication with		Bearing designation
d	D	D ₁	B	C	C ₁	T	T ₁	r _{1s}	r _{2s}	s	dynamic	static	P _u	grease	oil	Cone/Cup
								min	min		C _r	C _{or}		min ⁻¹		
mm											kN		kN	min ⁻¹		
66,675	110		22,0	18,82		22,0		0,80	1,3	-0,8	86,4	116	14	3400	4500	395A/ 394A
66,675	112,712		30,0	23,81		30,2		3,50	3,3	4,8	111	164	20	3400	4500	3984/ 3920
66,675	122,238		38,4	29,72		38,1		3,50	3,3	11,1	191	249	30	3200	4300	HM212049/ 212011
68,262	110		22,0	18,82		22,0		5,00	1,3	-0,8	86,4	116	14	3400	4500	399AS/ 394A
69,85	117,475		30,2	23,81		30,2		3,50	3,3	2,8	118	179	22	3200	4200	33275/ 33462
69,85	120		30,2	23,44		29,8		3,50	0,8	2,2	118	179	22	3200	4200	33275/ 33472
71,438	117,475		30,2	23,81		30,2		3,50	3,3	2,8	118	179	22	3200	4200	33281/ 33462
73,025	112,712		25,4	19,05		25,4		3,50	3,3	-0,9	97	155	19	3200	4300	29685/ 29620
73,025	117,475		30,2	23,81		30,2		3,50	3,3	2,8	118	179	22	3200	4200	33287/ 33462
80,962	150,089		46,7	36,51		44,5		5,00	3,3	11,7	264	368	43	2500	3400	740/ 742
82,55	125,412		25,4	19,85		25,4		3,50	1,5	-0,7	101	162	20	2900	3800	27687/ 27620
82,55	133,35		33,3	26,20		33,3		3,50	3,3	4,2	154	245	29	2700	3700	47686/ 47620
82,55	139,992		36,1	28,58		36,5		3,50	3,3	5,5	175	262	31	2700	3600	580/ 572
82,55	146,05		41,3	31,75		41,3		3,50	3,3	7,6	208	301	35	2600	3400	663/ 653
85,026	150,089		46,7	36,51		44,5		3,50	3,3	11,7	264	368	43	2500	3400	749/ 742
88,9	152,4		39,7	30,16		39,7		6,40	3,3	4,5	230	344	40	2000	3000	K-HM518445/ K-HM518410
89,974	146,975		40,0	32,50		40,0		7,00	3,5	9,3	243	365	42	2400	3300	K-HM218248/ K-HM218210

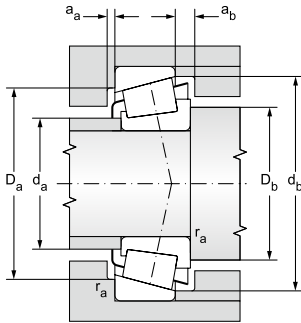

Abutment and fillet dimensions										Weight	Dimension deviations						Factors		
d_a	d_b	D_a	D_d	D_d	a_a	a_b	r_a	r_b	r_b	~	Δd_{mp}		ΔD_{mp}		ΔT_s		e	γ	γ_o
max	min	min	max	min	min	min	max	max			max	min	max	min	max	min			
mm										kg	μm								
73,0	73,00	101	102,5	104	4,5	4,00	0,8	1,3		1,06	+13	0	+25	0	+203	0	0,4	1,49	0,8
74,0	80,00	99	100,5	106	3,5	6,50	3,5	3,3		0,78	+13	0	+25	0	+203	0	0,4	1,49	0,8
82,0	75,00	108	109,5	116	9,0	6,50	3,5	3,3		1,84	+13	0	+25	0	+203	0	0,34	1,78	1,0
74,0	83,00	101	102,5	104	4,5	4,00	5,0	1,3		0,72	+13	0	+25	0	+203	0	0,4	1,49	0,8
77,0	84,00	104	105,5	112	3,5	6,50	3,5	3,3		1,25	+13	0	+25	0	+203	0	0,44	1,38	0,8
77,0	84,00	104	105,5	112	3,5	6,50	3,5	3,3		1,25	+13	0	+25	0	+203	0	0,44	1,38	0,8
79,0	85,00	104	105,5	112	3,5	6,50	3,5	3,3		1,18	+13	0	+25	0	+203	0	0,44	1,38	0,8
80,0	86,00	101	102,5	109	3,5	6,00	3,5	3,3		0,88	+13	0	+25	0	+203	0	0,49	1,23	0,7
80,0	87,00	104	105,5	112	3,5	6,50	3,5	3,3		1,17	+13	0	+25	0	+203	0	0,44	1,38	0,8
91,0	101,00	134	135,5	142	7,0	9,50	5,0	3,3		3,39	+25	0	+25	0	+203	0	0,33	1,84	1,0
89,0	96,00	115	116,5	120	4,0	6,50	3,5	1,5		1,04	+25	0	+25	0	+203	0	0,42	1,44	0,8
90,0	97,00	119	120,5	128	5,0	7,50	3,5	3,3		1,69	+25	0	+25	0	+203	0	0,4	1,48	0,8
91,0	98,00	125	126,5	133	4,0	7,00	3,5	3,3		2,14	+25	0	+25	0	+203	0	0,4	1,49	0,8
92,0	99,00	131	132,5	139	5,0	8,00	3,5	3,3		2,75	+25	0	+25	0	+203	0	0,41	1,47	0,8
95,0	101,00	134	135,5	142	7,0	9,50	3,5	3,3		3,21	+25	0	+25	0	+203	0	0,33	1,84	1,0
98,0	112,00	124	135	142	6,0	10,00	3,5			2,88	+25	0	+25	0	+200	0	0,44	1,36	0,8
99,0	112,00	128	133	141	6,0	7,50	3,5			2,59	+25	0	+25	0	+200	0	0,33	1,8	1,0



Single row tapered roller bearings in inch dimensions

d = 90 to 146.05 mm

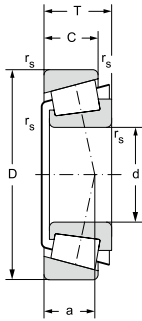

12.6.2

Main dimensions											Basic load rating		Fatigue load limit	Limiting speed for lubrication with		Bearing designation
d	D	D ₁	B	C	C ₁	T	T ₁	r _{1s}	r _{2s}	s	dynamic	static	P _u	grease	oil	Cone/Cup
								min	min		C _r	C _{or}				
mm											kN		kN	min ⁻¹		
90	145		34,0	27,00		35,0		6,00	2,5	2,2	213	315	37	2200	3200	K-JM718149/ K-JM718110
92,075	152,4		36,3	30,16		39,7		3,50	3,3	4,5	183	287	33	2400	3300	598/ 592A
146,05	193,675		28,6	23,02		28,6		5,80	1,5	-5,4	181	390	41	1700	2200	K-36691/

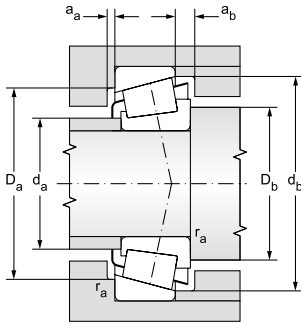

Abutment and fillet dimensions										Weight	Dimension deviations						Factors		
d_a	d_b	D_a	D_b	D_d	d_a	a_b	r_a	r_b		~	Δd_{mp}		ΔD_{mp}		ΔT_s		e	γ	γ_o
max	min	min	max	min	min	min	max	max			max	min	max	min	max	min			
mm										kg	μm								
99,0	111,00	126	131	140	6,0	8,00	2,5			2,15	+25	0	+25	0	+200	0	0,44	1,35	0,8
101,0	107,00	135	136,5	144	1,0	8,00	3,5	3,3		2,61	+25	0	+25	0	+203	0	0,44	1,36	0,8
155,0	162,00	176	182	187	6,0	6,50	1,5			2,31	+25	0	+25	0	+356	-254	0,37	1,6	0,9



Four-row tapered roller bearings $d = 160$ to 630 mm

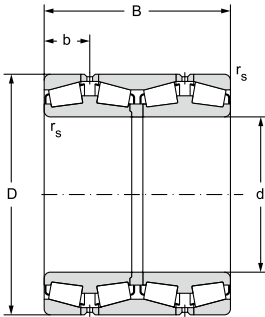

12.6.3

Main dimensions						Basic load rating		Fatigue load limit
d	D	B	r_{1s}	r_{2s}	b	dynamic	static	P_u
			min	min		C_r	C_{or}	
mm						kN		kN
160	240	145	2,5	2,5	34,25	799	1720	170
170	260	160	2,5	2,5	37,75	990	2140	210
180	280	180	2,5	2,5	42,50	1150	2490	240
190	290	180	2,5	2,5	42,50	1170	2600	240
200	310	200	2,5	2,5	47,50	1420	3110	290
220	340	218	3,0	3,0	51,75	1680	3770	340
240	360	218	3,0	3,0	51,75	1700	3920	340
260	400	250	4,0	4,0	59,75	2230	5080	430
280	420	250	4,0	4,0	59,75	2270	5290	440
300	460	290	4,0	4,0	69,25	2910	6760	550
320	480	290	4,0	4,0	69,25	2960	7040	570
340	520	325	5,0	5,0	77,50	3520	8530	670
360	480	218	3,0	3,0	51,75	2170	5990	480
	540	325	5,0	5,0	77,50	3580	8870	690
380	560	325	5,0	5,0	77,50	3650	9200	710
400	600	355	5,0	5,0	84,75	4340	10600	800
420	620	355	5,0	5,0	84,75	4420	11100	820
500	720	400	6,0	6,0	95,00	5390	14300	1 000
525	780	450	6,0	6,0	106,50	6660	17600	1 200
530	780	450	6,0	6,0	106,50	6660	17600	1 200
630	920	515	7,5	7,5	125,00	8730	24200	1 600

Limiting speed for lubrication with		Bearing designation	Weight	Factors			
grease	oil			~	e	Y1	Y2
min ⁻¹			kg				
710	940	36032	23,6	0,45	1,5	2,2	1,5
630	840	36034	30	0,46	1,5	2,2	1,5
590	780	36036	40,5	0,45	1,5	2,2	1,5
540	720	36038	42,5	0,47	1,4	2,2	1,4
500	670	36040	51,5	0,44	1,5	2,3	1,5
420	560	36044	71,6	0,45	1,5	2,3	1,5
400	530	36048	76,3	0,48	1,4	2,1	1,4
330	450	36052	111	0,44	1,5	2,3	1,5
320	420	36056	117	0,47	1,4	2,1	1,4
290	380	36060	169	0,44	1,5	2,3	1,5
260	340	36064	177	0,47	1,4	2,2	1,4
240	320	36068	241	0,44	1,5	2,3	1,5
240	320	36972	113	0,43	1,6	2,3	1,5
220	290	36072	253	0,46	1,5	2,2	1,4
200	260	36076**	263	0,48	1,4	2,1	1,4
190	250	36080**	339	0,44	1,5	2,3	1,5
180	240	36084**	351	0,46	1,5	2,2	1,4
140	190	360/500**	504	0,47	1,4	2,1	1,4
126	170	360/525**	713	0,45	1,5	2,2	1,5
120	160	360/530**	693	0,45	1,5	2,2	1,5
94	126	360/630**	1090	0,44	1,5	2,3	1,5







12.7 THRUST BALL BEARINGS

Design

From a design perspective, thrust ball bearings are divided into single direction and double direction. Rings have flat seating surfaces. The rings in smaller bearings may alternatively have a round seating faces (see fig. 12.7.1) for seating in the hub. Rings must be supported such that all of the balls or loaded equally. Bearings cannot carry radial forces. The bearings can be disassembled; consequently, the rings and axial cages with balls can be taken apart.



Fig. 12.7.1

Single direction thrust bearings

Standard single direction thrust ball bearings are composed of a shaft and hub ring with races and of balls guided by a cage (see fig. 12.7.2). Bearings only transfer axial loads in one direction.

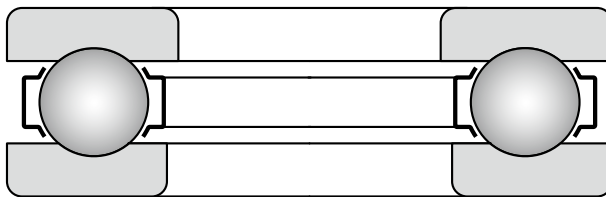

Fig. 12.7.2

Double direction thrust bearings

Standard double direction thrust ball bearings have two cages with balls between the centre shaft ring and two housing rings (see fig. 12.7.3). The shaft ring has races on both sides and is fastened on the journal. Bearings are only capable of transferring axial forces in both directions. Housing rings and cages with balls have identical components as single direction bearings of similar dimensions.

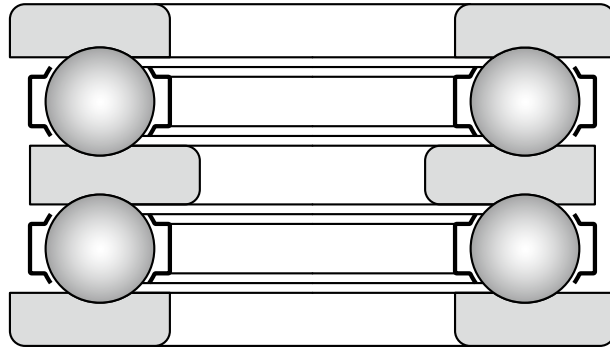

Fig. 12.7.3

Cages

Thrust ball bearings, in standard design, have a sheet metal cage according to fig. 12.7.4.

Larger size bearings use massive brass or steel cages (fig. 12.7.5).

In the rare exception, cages made from fibre-glass reinforced polyamide 6.6 are used.

Designation of the material and design is not specified in standard cages made from pressed steel sheeting. Any customer demands for special variations of cage structure and material must be consulted in advance with the supplier.

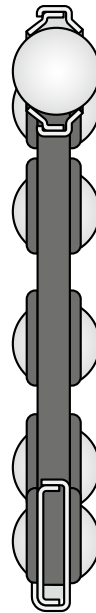

Fig. 12.7.4

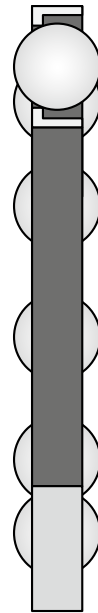

Fig. 12.7.5

Basic information

Dimensions

The main dimensions of bearings are consistent with standard ISO 104 and are listed for individual bearings in the tables of the publication.

Precision

Bearings are currently produced at a normal degree of precision P0, which is not marked. Bearings are also supplied for more demanding loading at higher degrees of precision, P6 and P5. The availability of precision P5 bearings must be discussed with the supplier.

The dimensional and operational precision tolerances are listed in tables 7.16a and 7.16b and are consistent with standard ISO 199.

Self-alignment ability

Bearings require that seating surface alignment tolerances be respected, because misalignment causes increased stress during contact of the balls with raceways. Thrust ball bearings with a flat housing ring face therefore should not be used, where conditions of alignment cannot be secured.

Bearings with a round housing ring face can be used for compensating misalignment (not for axial displacement) of axial bearing rings. Bearings are then installed with a spherical housing ring, and can thus compensate the above specified misalignment – see fig. 12.7.6.

Minimal load

Balls may slide between the ring raceways at higher speeds or during sudden changes in rotation. These slippages, which damage the bearings, are caused by centrifugal or inertial forces. In order to prevent damage, the axial load F_a must not drop during operation below the permitted value. We can calculate the permitted value $F_{a\ min}$ from the equation:

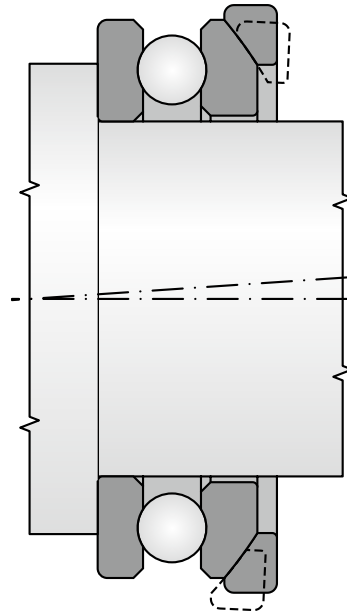

Fig. 12.7.6



$$F_{a\ min} = M \left[\frac{n_{\max}}{1000} \right]^2$$

$F_{a\ min}$ minimal axial load [kN]

n_{\max} maximum rotation speed [min^{-1}]

M coefficient of minimum axial load

The values are provided in the tables of the publication.

If it should occur that the value of the axial load drops below the value $F_{a\ min}$, which can occur e.g. wherever there is unloading of the bearing during operation, e.g. of one row of balls in a double direction bearing or one bearing when using a pair of single direction thrust bearings, resp., minimal loading must be secured, e.g. by the use of springs.

Bearing equivalent dynamic load capacity

$$P_a = F_a$$

Bearing equivalent static load capacity

$$P_{0a} = F_a$$

Additional markings

Labelling of standard bearings is specified in the tables of the publication. Divergence from the standard design is marked by additional characters.

- F** Massive steel cage, guided by rolling elements
- M** Massive brass cage, guided by rolling elements
- P6** Increased precision of dimensions and operation compared to the standard version (ISO 199)
- P5** Increased precision of dimensions and operation compared to P6 (ISO 199)
- TNG** Injected cage made from fibreglass reinforced polyamide 6.6, ball-guided

Structure of related components

As specified earlier in the article on structure, smaller bearings may have housing rings with a spherical seating surface. Housing ring with a spherical surface that carry a load between the housing ring and the bearings - "U" rings, can also be supplied for these bearings – See fig. 12.7.7.

The availability of these rings must be consulted with the supplier. Rings are made from bearing steel and are unhardened. At request and subject to approval by the supplier, hardened rings can also be supplied.

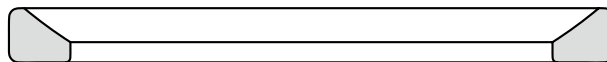
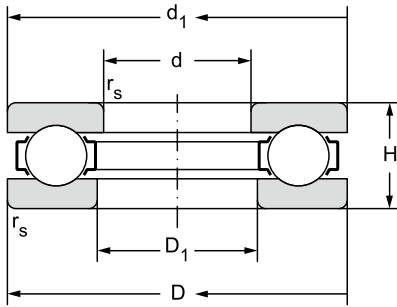

Fig. 12.7.7



Single direction thrust ball bearings d = 160 to 630 mm

d = 10 to 50 mm



12.7.1

Main dimensions						Basic load rating		Fatigue load limit	Limiting speed for lubrication with	
d	D	d ₁	D ₁	H	r _s min	dynamic	static	P _u	grease	oil
						C _a	C _{0a}			
mm						kN		kN	min ⁻¹	
10	24	24	11	9	0,3	11,2	14,0	0,64	7900	10600
12	26	26	13	9	0,3	11,5	15,4	0,70	7500	10000
15	28	28	16	9	0,3	11,8	16,8	0,76	7100	9400
	32	13	17	12	0,6	17,3	24,4	1,11	6000	7900
17	30	30	18	9	0,3	12,7	19,6	0,89	7100	9400
	35	35	19	12	0,6	17,8	26,6	1,21	5600	7500
20	35	35	21	10	0,3	16,8	26,6	1,21	6300	8400
	40	40	22	14	0,6	24,5	37,7	1,71	5000	6700
25	42	42	26	11	0,6	20,3	35,5	1,61	5300	7100
	47	47	27	15	0,6	30,6	50,5	2,30	4500	6000
	52	52	27	18	1,0	38,9	61,5	2,80	3800	5000
	60	60	27	24	1,0	60,5	89,4	4,06	3200	4200
30	47	47	32	11	0,6	21,1	39,9	1,81	5000	6700
	52	52	32	16	0,6	30,3	58,2	2,65	4000	5300
	60	60	32	21	1,0	44,8	78,7	3,58	3300	4500
	70	70	32	28	1,0	79,2	126,0	5,73	2700	3500
35	52	52	37	12	0,6	22,5	46,6	2,12	4700	6300
	62	62	37	18	1,0	41,8	78,2	3,55	3500	4700
	68	68	37	24	1,0	58,8	105,0	4,77	2800	3800
	80	80	37	32	1,1	94,7	155,0	7,05	2200	3000
40	60	60	42	13	0,6	30,1	62,9	2,86	4200	5600
	68	68	42	19	1,0	48,4	92,4	4,20	3200	4200
	78	78	42	26	1,0	73,5	135,0	6,14	2700	3500
	90	90	42	36	1,1	122,0	205,0	9,32	2000	2700
45	65	65	47	14	0,6	31,3	69,2	3,15	4000	5300
	73	73	47	20	1,0	47,0	105,0	4,77	3000	4000
	85	85	47	28	1,0	87,2	164,0	7,45	2400	3200
	100	100	47	39	1,1	142,0	243,0	11,1	1900	2500
50	70	70	52	14	0,6	32,3	75,5	3,43	3800	5000
	78	78	52	22	1,0	51,9	111,0	5,05	2800	3800
	95	95	52	31	2,0	96,6	202,0	9,17	2200	3040

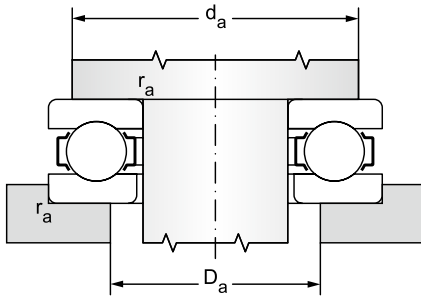

** Bearings in the new standard NEW FORCE

Bearing designation	Abutment and fillet dimensions			Weight	Minimum axial load factor
	d_a	D_a	r_a		
	min	max	max		
	mm			kg	
51100**	19	15	0,3	0,020	0,001
51101**	21	17	0,3	0,0	0,002
51102**	23	20	0,3	0,0	0,002
51202**	25	22	0,6	0,1	0,004
51103**	25	22	0,3	0,0	0,003
51203**	28	24	0,6	0,1	0,004
51104**	29	26	0,3	0,0	0,004
51204**	32	28	0,6	0,1	0,008
51105**	35	32	0,6	0,1	0,006
51205**	38	34	0,6	0,1	0,015
51305**	41	36	1,0	0,2	0,020
51405**	46	39	1,0	0,3	0,035
51106**	40	37	0,6	0,1	0,008
51206**	43	39	0,6	0,1	0,018
51306**	48	42	1,0	0,3	0,030
51406**	54	46	1,0	0,5	0,085
51107**	45	42	0,6	0,1	0,012
51207**	51	46	1,0	0,2	0,032
51307**	55	48	1,0	0,4	0,050
51407**	62	53	1,0	0,8	0,120
51108**	52	48	0,6	0,1	0,018
51208**	57	51	1,0	0,3	0,047
51308**	63	55	1,0	0,6	0,095
51408TNGN**	70	60	1,0	1,1	0,190
51109**	57	53	0,6	0,2	0,025
51209**	62	56	1,0	0,3	0,060
51309**	69	61	1,0	0,7	0,130
51409**	78	67	1,0	1,5	0,350
51110**	62	58	0,6	0,2	0,035
51210**	67	61	1,0	0,4	0,082
51310	68	77	2,0	1,0	0,190



Single direction thrust ball bearings

d = 55 to 100 mm

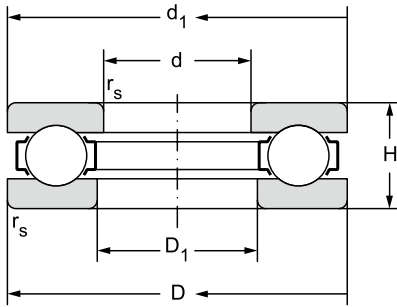

12.71

Main dimensions						Basic load rating		Fatigue load limit	Limiting speed for lubrication with	
d	D	d ₁	D ₁	H	r _s min	dynamic	static	P _u	grease	oil
						C _a	C _{0a}			
mm						kN		kN	min ⁻¹	
55	78	78	57	16	0,6	36,5	93,2	4,24	3300	4500
	90	90	57	25	1,0	73,6	159,0	7,2	2500	3300
	105	105	57	35	1,1	123,0	246,0	11,2	1900	2500
	120	120	57	48	1,5	214,0	397,0	18,1	1600	2100
60	85	85	62	17	1,0	46,4	113,0	5,1	3200	4200
	110	110	62	35	1,1	125,0	270,0	12,3	1900	2500
65	90	90	67	18	1,0	44,6	117,0	5,32	2300	3400
	100	100	67	27	1,0	76,4	189,0	8,6	2400	3200
	115	115	67	36	1,1	129,0	287,0	13,1	1800	2400
70	95	95	72	18	1,0	46,6	127,0	5,77	2800	3800
	105	105	72	27	1,0	76,9	199,0	9,1	2200	3000
	125	125	72	40	1,1	158,0	340,0	15,5	1700	2200
	150	150	73	60	2,0	273,0	553,0	24,0	1200	1600
75	100	100	77	19	1,0	49,8	136,0	6,18	2700	3500
	110	110	77	27	1,0	81,2	209,0	9,5	2200	3000
	135	135	77	44	1,5	193,0	426,0	18,9	1600	2100
80	105	105	82	19	1,0	50,0	141,0	6,41	2700	3500
	115	115	82	28	1,0	86,4	219,0	10,0	2000	2700
	170	170	83	68	2,1	327,0	751,0	30,5	890	1200
85	110	110	87	19	1,0	51,5	150,0	6,8	2700	3500
	125	125	88	31	1,0	105,0	264,0	11,7	2000	2700
	150	150	88	49	1,5	227,0	517,0	21,7	1300	1800
90	120	120	92	22	1,0	66,9	190,0	8,4	2000	2700
	155	155	93	50	1,5	237,0	556,0	22,8	1100	1500
	190	187	93	77	2,1	385,0	970,0	37,3	790	1060
100	135	135	102	25	1,0	95,3	268,0	11,2	2000	2700
100	170	170	103	55	1,5	266,0	628,0	24,6	1060	1400
100	210	205	103	85	3,0	453,0	1220,0	44,5	750	1000
100	210	205	103	85	3,0	453,0	1220,0	44,5	750	1000

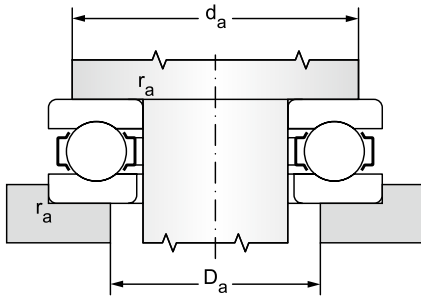

** Bearings in the new standard NEW FORCE

Bearing designation	Abutment and fillet dimensions			Weight	Minimum axial load factor
	d_a	D_a	r_a		
	min	max	max		
	mm			kg	
51111**	69	64	0,6	0,2	0,040
51211**	76	69	1,0	0,6	0,110
51311**	85	75	1,0	1,3	0,270
51411**	94	81	1,5	2,6	0,650
51112**	75	70	1,0	0,3	0,066
51312**	90	80	1,0	1,4	0,350
51113**	80	75	1,0	0,3	0,086
51213**	86	79	1,0	0,8	0,170
51313**	95	85	1,0	1,6	0,450
51114**	85	80	1,0	0,4	0,110
51214**	91	84	1,0	0,8	0,210
51314**	103	92	1,0	2,1	0,540
51414**	118	102	2,0	5,5	1,600
51115**	90	85	1,0	0,4	0,120
51215**	96	89	1,0	0,9	0,270
51315**	111	99	1,5	2,7	0,760
51116**	95	90	1,0	0,4	0,150
51216**	101	94	1,0	1,0	0,350
51416**	133	117	2,0	8,0	2,700
51117**	100	95	1,0	0,5	0,180
51217**	109	101	1,0	1,3	0,430
51317**	123	111	1,5	3,7	1,200
51118**	108	102	1,0	0,7	0,260
51318**	129	116	1,5	3,9	1,500
51418**	149	131	2,0	11,2	4,100
51120**	121	114	1,0	1,0	0,340
51320**	142	128	1,5	5,1	2,000
51420M**	165	145	2,5	15,6	7,700
51420F**	165	145	2,5	15,0	6,200



Single direction thrust ball bearings

d = 110 to 160 mm

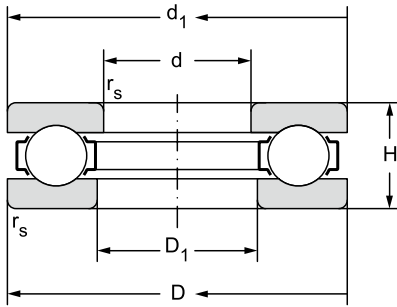

12.7.1

Main dimensions						Basic load rating		Fatigue load limit	Limiting speed for lubrication with	
d	D	d ₁	D ₁	H	r _s	dynamic	static	P _u	grease	oil
						C _a	C _{0a}			
mm						kN		kN	min ⁻¹	
110	145	145	112	25	1,0	97,8	288,0	11,6	1900	2500
	190	187	113	63	2,0	323,0	807,0	30,0	890	1200
	190	187	113	63	2,0	280,0	744,0	27,6	890	1200
	230	225	113	95	3,0	496,0	1400,0	48,8	670	890
	230	225	113	95	3,0	496,0	1400,0	48,8	670	890
120	155	155	122	25	1,0	95,1	308,0	11,9	1600	2100
	210	205	123	70	2,1	369,0	977,0	34,6	790	1060
	250	245	123	102	4,0	566,0	1590,0	53,1	630	840
	250	245	123	102	4,0	566,0	1590,0	53,1	630	840
130	170	170	132	30	1,0	127,0	406,0	15,1	1400	1900
	190	187	133	45	1,5	184,0	537,0	19,3	1170	1600
	225	220	134	75	2,1	389,0	1070,0	36,5	750	1000
	225	220	134	75	2,1	389,0	1070,0	36,5	750	1000
	225	220	134	75	2,1	358,0	1050,0	35,8	830	1100
	270	265	134	110	4,0	643,0	2010,0	64,6	560	750
	270	265	134	110	4,0	643,0	2010,0	64,6	560	750
140	240	235	144	80	2,1	439,0	1260,0	41,6	710	940
	240	235	144	80	2,1	439,0	1260,0	41,6	710	940
	240	235	144	80	2,1	407,0	1250,0	41,2	790	1040
150	190	188	152	31	1,0	132,0	448,0	15,6	1300	1800
	190	188	152	31	1,0	117,0	420,0	14,6	1250	1700
	190	188	152	31	1,0	117,0	420,0	14,6	1250	1700
	215	212	153	50	1,5	282,0	835,0	28,1	900	1300
	215	212	153	49,9	1,5	236,0	733,0	24,7	970	1400
	250	245	154	80	2,1	455,0	1360,0	43,7	670	900
	250	245	154	80	2,1	455,0	1360,0	43,7	670	900
	250	245	154	80	2,1	419,0	1340,0	43,1	750	1000
160	200	198	162	31	1,0	134,0	476,0	16,1	1300	1800
	200	198	162	31	1,0	121,0	448,0	15,2	1250	1700
	200	198	162	31	1,0	121,0	448,0	15,2	1250	1700
	225	222	163	51	1,5	289,0	874,0	28,6	890	1200
	225	222	163	51	1,5	239,0	768,0	25,2	1040	1400

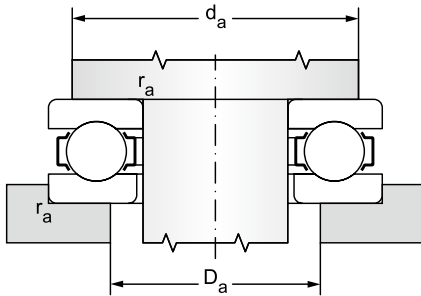

** Bearings in the new standard NEW FORCE

Bearing designation	Abutment and fillet dimensions			Weight	Minimum axial load factor
	d_a	D_a	r_a		
	min	max	max		
	mm			kg	
51122**	131	124	1,0	1,1	0,420
51322**	158	142	2,0	7,9	2,800
51322M	158	142	2,0	7,8	3,100
51422M**	181	159	2,5	20,2	9,000
51422F**	181	159	2,5	20,2	9,000
51124**	141	134	1,0	1,2	0,530
51324**	173	157	2,0	10,9	4,100
51424M**	197	173	3,0	25,5	13,000
51424F**	197	173	3,0	25,5	13,000
51126**	154	146	1,0	1,9	0,650
51226**	167	153	1,5	3,9	1,700
51326M**	186	169	2,0	13,3	6,200
51326F**	186	169	2,0	13,3	6,200
51326M	186	168	2,0	12,9	6,000
51426M**	213	187	3,0	32,0	18,000
51426F**	213	187	3,0	32,0	18,000
51328M**	199	181	2,0	15,9	8,000
51328F**	199	181	2,0	15,9	8,000
51328M	199	181	2,0	15,6	8,400
51130**	174	166	1,0	2,2	0,950
51130M**	174	166	1,0	2,3	1,000
51130F**	174	166	1,0	2,3	1,000
51230**	189	176	1,5	6,1	2,800
51230M	189	176	1,5	6,1	3,000
51330M**	209	191	2	16,5	10,000
51330F**	209	191	2,0	16,5	10,000
51330M	209	191	2,0	16,2	9,400
51132**	184	176	1,0	2,3	1,200
51132M**	199	186	1,5	2,3	1,200
51132F**	199	186	1,5	2,3	1,200
51232**	199	186	1,5	6,7	3,200
51232M	199	186	1,5	6,5	3,300



Single direction thrust ball bearings

d = 170 to 280 mm

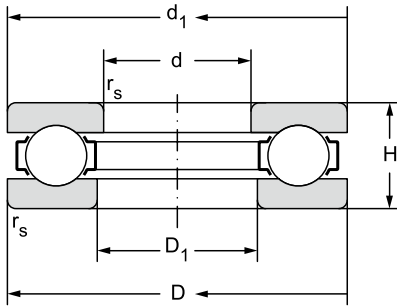

12.7.1

Main dimensions						Basic load rating		Fatigue load limit	Limiting speed for lubrication with	
d	D	d ₁	D ₁	H	r _s	dynamic	static		P _u	grease
mm						kN		kN		min ⁻¹
						C _a	C _{0a}			
						min				
170	215	213	172	34	1,1	160,0	582,0	19,1	1200	1600
	215	213	172	34	1,1	154,0	563,0	18,5	1100	1500
	215	213	172	34	1,1	154,0	563,0	18,5	1100	1500
	240	237	173	55	1,5	301,0	897,0	28,5	840	1100
	240	237	173	55	1,5	283,0	930,0	29,5	920	1200
180	225	222	185	34	1,1	166,0	639,0	20,4	1100	1500
	225	222	185	34	1,1	152,0	563,0	18,0	1030	1400
	225	222	185	34	1,1	152,0	563,0	18,0	1030	1400
	250	247	183	56	1,5	325,0	1030,0	31,9	840	1100
	250	245	183	56	1,5	303,0	1030,0	32,0	920	1200
	250	247	183	56	1,5	294,0	987,0	30,6	770	1050
	250	247	183	56	1,5	294,0	987,0	30,6	770	1050
190	240	237	193	37	1,1	200,0	715,0	22,2	1060	1400
	270	267	194	62	2,0	382,0	1240,0	37,2	750	1000
	270	267	194	62	2,0	382,0	1240,0	37,2	750	1000
	270	265	194	62	2,0	334,0	1170,0	35,1	830	1100
200	250	247	203	37	1,1	197,0	738,0	22,4	1060	1400
	250	247	203	37	1,1	184,0	715,0	21,7	950	1300
	250	247	203	37	1,1	184,0	715,0	21,7	950	1300
	280	277	204	62	2,0	377,0	1240,0	36,4	750	1000
	280	277	204	62	2,0	377,0	1240	36,4	750	1000
	280	275	204	62	2,0	339,0	1220	35,8	830	1100
220	270	267	223	37	1,1	200,0	805,0	23,4	1000	1300
	270	267	223	37	1,1	187,0	760,0	22,1	880	1200
	270	267	223	37	1,1	187,0	760,0	22,1	880	1200
240	300	297	243	45	1,5	277,0	1040,0	28,8	840	1100
	300	297	243	45	1,5	277,0	1040,0	28,8	840	1100
	340	335	244	78	2,1	461,0	2000,0	53,4	600	800
260	320	317	263	45	1,5	272,0	1120,0	29,9	800	1100
	360	355	264	79	2,1	470,0	2160,0	55,8	560	750
280	350	347	283	53	1,5	312,0	1460,0	37,4	700	950
	380	375	284	80	2,1	483,0	2320,0	58,1	560	750

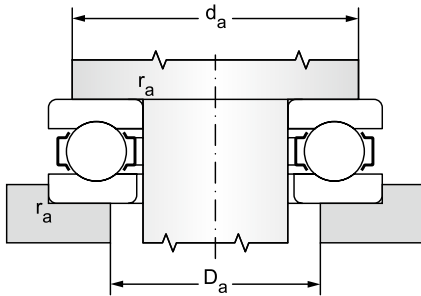

** Bearings in the new standard NEW FORCE

Bearing designation	Abutment and fillet dimensions			Weight	Minimum axial load factor
	d_a	D_a	r_a		
	min	max	max		
	mm			kg	
51134**	197	188	1,0	3,3	1,500
51134M**	212	198	1,5	3,0	1,800
51134F**	212	198	1,5	3,0	1,800
51234**	212	198	1,5	8,3	4,600
51234M	212	198	1,5	8,0	4,600
51136**	207	198	1,0	3,0	1,900
51136M**	207	198	1,0	3,1	1,900
51136F**	207	198	1,0	3,1	1,900
51236**	222	208	1,5	8,3	5,500
51236M**	220	208	1,5	8,5	5,500
51236F**	222	208	1,5	8,7	5,300
51236M	222	208	1,5	8,7	5,300
51138**	220	210	1,0	4,1	2,400
51238M**	238	222	2,0	11,9	8,400
51238F**	238	222	2,0	11,9	7,500
51238M	236	222	2,0	11,6	7,300
51140**	230	220	1,0	4,0	3,100
51140M**	230	220	1,0	4,2	2,900
51140F**	230	220	1,0	4,2	2,900
51240M**	248	232	2,0	12,4	9,500
51240F**	248	232	2,0	12,4	9,500
51240M	246	232	2,0	12,1	8,000
51144**	250	240	1,0	4,4	4,600
51144M**	250	240	1,0	4,6	3,300
51144F**	250	240	1,0	4,6	3,300
51148M**	276	264	1,5	7,6	6,500
51148F**	276	264	1,5	7,6	6,500
51248M	299	281	2,0	23,0	23,000
51152M	296	284	1,5	8,1	6,800
51252M	319	301	2,0	25,0	26,000
51156M	322	308	1,5	12,0	12,000
51256M	339	321	2,0	26,5	30,000



Single direction thrust ball bearings

d = 300 to 670 mm

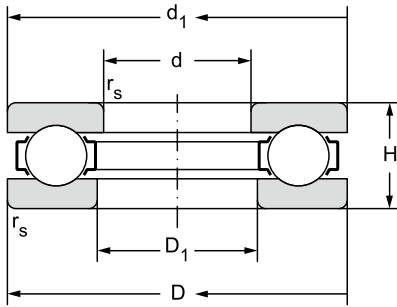

12.7.1

Main dimensions						Basic load rating		Fatigue load limit	Limiting speed for lubrication with	
d	D	d ₁	D ₁	H	r _s min	dynamic	static	P _u	grease	oil
						C _a	C _{0a}		min ⁻¹	
mm						kN		kN	min ⁻¹	
300	380	376	304	62	2,0	359,0	1770,0	43,6	630	850
	420	415	304	95	3,0	590,0	3010,0	72,1	480	630
320	400	396	324	63	2,0	364,0	1860,0	44,6	600	800
	440	435	325	95	3,0	577,0	3010,0	70,2	450	600
340	420	416	344	64	2,0	369,0	1990,0	46,4	600	800
	460	456	345	96	3,0	606,0	3280,0	74,5	450	600
360	440	436	364	65	2,0	378,0	2080,0	47,3	560	750
	500	495	365	110	4,0	728,0	4200,0	92,1	400	530
380	460	456	384	65	2,0	383,0	2200,0	48,8	550	740
	520	515	385	112	4,0	704,0	4120,0	88,3	380	500
400	480	476	404	65	2,0	410,0	2300,0	49,8	530	700
420	500	496	424	65	2,0	412,0	2410,0	51,1	510	680
440	540	536	444	80	2,1	525,0	3200,0	65,7	450	600
460	560	556	464	80	2,1	530,0	3230,0	65,0	440	580
480	580	576	484	80	2,1	540,0	3290,0	65,0	430	560
500	600	596	504	80	2,1	560,0	3370,0	65,3	420	550
530	640	636	534	85	3,0	645,0	4380,0	82,3	400	530
560	670	666	564	85	3,0	665,0	4660,0	85,4	380	500
600	710	706	604	85	3,0	663,0	4800,0	85,3	370	490
630	750	746	634	95	3,0	730,0	5430,0	94,0	340	450
670	800	795	675	105	4,0	850,0	6680,0	112,0	300	400

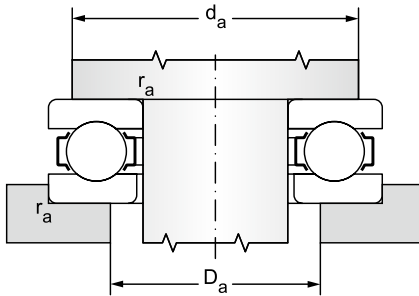

** Bearings in the new standard NEW FORCE

Bearing designation	Abutment and fillet dimensions			Weight	Minimum axial load factor
	d_a	D_a	r_a		
	min	max	max		
	mm			kg	
51160M	348	332	2,0	17,5	17,000
51260M	371	349	2,5	42,0	49,000
51164M	368	352	2,0	19,0	20,000
51264M	391	369	2,5	45,5	49,000
51168M	388	372	2,0	20,5	22,000
51268M	411	389	2,5	48,5	54,000
51172M	408	392	2,0	22,0	27,000
51272M	443	417	3,0	70,0	93,000
51176M	428	412	2,0	23,0	29,000
51276M	463	437	3,0	73,0	93,000
51180M**	448	432	2,0	24,0	30,000
51184M**	468	452	2,0	25,5	33,000
51188M**	499	481	2,0	42,0	59,000
51192M**	519	501	2,0	43,5	60,000
51196M**	539	521	2,0	45,5	68,000
511/500M**	559	541	2,0	46,5	70,000
511/530M**	595	575	2,5	58,5	105,000
511/560M**	625	606	2,5	61,0	116,000
511/600M**	665	645	2,5	65,0	124,000
511/630M**	701	679	2,5	84,0	158,000
511/670M**	747	723	3,0	105,0	234,000



Double direction thrust ball bearings d = 10 to 140 mm

d = 10 to 55 mm

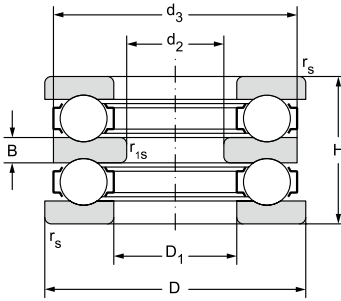

12.7.2

Main dimensions								Basic load rating		Fatigue load limit
d ₂	D	d ₃	D1	H	B	r _s	r _{1s}	dynamic	static	P _u
						min	min	C _a	C _{oa}	P _u
mm								kN		kN
10	32	32	17	22	5	0,6	0,3	17,27	24,4	1,11
15	40	40	22	26	6	0,6	0,3	24,53	37,7	1,71
	60	60	27	45	11	1	0,6	60,5	89,4	4,06
20	47	47	27	28	7	0,6	0,3	30,58	50,5	2,3
	52	52	27	34	8	1	0,3	38,91	61,5	2,8
	70	70	32	52	12	1	0,6	79,24	126	5,73
25	52	52	32	29	7	0,6	0,3	30,28	58,2	2,65
	60	60	32	38	9	1	0,3	44,84	78,7	3,58
	80	80	37	59	14	1,1	0,6	94,72	155	7,05
30	62	62	37	34	8	1	0,3	41,45	78,2	3,55
	68	68	37	44	10	1	0,3	60,5	105	4,77
	68	68	42	36	9	1	0,6	48,4	92,4	4,2
	78	78	42	49	12	1	0,6	74,15	135	6,14
	90	90	42	65	15	1,1	0,6	122,08	205	9,32
35	73	73	47	37	9	1	0,6	46,97	105	4,77
	85	85	47	52	12	1	0,6	87,2	164	7,45
	100	100	47	72	17	1,1	0,6	141,7	243	11,05
40	78	78	52	39	9	1	0,6	51,92	111	5,05
45	90	90	57	45	10	1	0,6	73,56	159	7,23
	105	105	57	64	15	1,1	0,6	123,76	246	11,18
	120	120	57	87	20	1,5	0,6	212,18	397	18,05
50	110	110	62	64	15	1,1	0,6	125,24	270	12,27
55	100	100	67	47	10	1	0,6	76,4	189	8,59
	115	115	67	65	15	1,1	0,6	129,28	287	13,05
	105	105	72	47	10	1	1	77,62	198	9
	125	125	72	72	16	1,1	1	161,32	340	15,45
	150	150	73	107	24	2	1	272,5	553	24,83

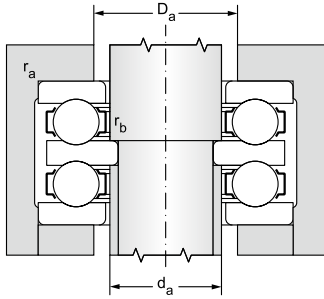

Limiting speed for lubrication with		Bearing designation	Abutment and fillet dimensions					Weight	Coefficient of minimum axial load
grease	oil		d ₂	d _a	D _a	r _a	r _b		
min ⁻¹				max	max	max	max	kg	
			mm						
6000	7900	52202**	10	15	22	0,6	0,3	0,08	0,004
5000	6700	52204**	15	20	28	0,6	0,3	0,15	0,008
3200	4200	52405**		25	39	1	0,6	0,63	0,035
4500	6000	52205**	20	25	34	0,6	0,3	0,23	0,015
3800	5000	52305**		25	36	1	0,3	0,33	0,02
2700	3500	52406**		30	46	1	0,6	1,00	0,085
4000	5300	52206**	25	30	39	0,6	0,3	0,27	0,018
3300	4500	52306**		30	42	1	3	0,49	0,03
2200	3000	52407**		35	53	1	0,6	1,44	0,12
3500	4700	52207**	30	35	46	1	0,3	0,42	0,032
2800	3800	52307**		35	48	1	0,3	0,71	0,05
3200	4200	52208**		40	51	1	0,6	0,54	0,047
2700	3500	52308**		40	55	1	0,6	1,06	0,095
2000	2700	52408TNGN**		40	60	1	0,6	2,03	0,19
3000	4000	52209**	35	45	56	1	0,6	0,62	0,06
2400	3200	52309**		45	61	1	0,6	1,29	0,13
1900	2500	52409**		45	67	1	0,6	2,71	0,35
2800	3800	52210**	40	50	61	1	0,6	0,71	0,082
2500	3300	52211**	45	55	69	1	0,6	1,12	0,11
1900	2500	52311**		55	75	1	0,6	2,51	0,27
1600	2100	52411**		55	81	1,5	0,6	4,70	0,65
1900	2500	52312**	50	60	80	1	0,6	2,68	0,35
2400	3200	52213**	55	65	79	1	0,6	1,36	0,17
1800	2400	52313**		65	85	1	0,6	2,90	0,45
2200	3000	52214**		70	84	1	0,6	1,48	0,21
1700	2200	52314**		70	92	1	1	3,90	0,54
1200	1600	52414**		70	102	2	1	9,71	1,6



Double direction thrust ball bearings

d = 60 to 140 mm

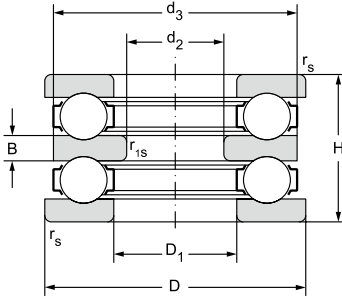

12.7.2

Main dimensions								Basic load rating		Fatigue load limit
d_2	D	d_3	D1	H	B	r_s	r_{1s}	dynamic	static	P_u
						min	min	C_a	C_{oa}	
mm								kN		kN
60	110	110	77	47	10	1	1	76,62	209	9,5
	135	135	77	79	18	1,5	1	193,2	426	19,36
65	115	115	82	48	10	1	1	86,35	219	9,95
	170	170	83	120	27	2,1	1	336,02	751	31,49
70	125	125	88	55	12	1	1	104,94	264	12
	150	150	88	87	19	1,5	1	243,07	517	22,41
	190	189,5	93	135	30	2,1	1,1	403,86	970	38,67
75	155	155	93	88	19	1,5	1	245,92	556	23,57
100	210	209,5	123	123	27	2,1	1,1	368,88	977	35,67
140	225	224,5	163	90	20	1,5	1,1	294,25	874	29,41

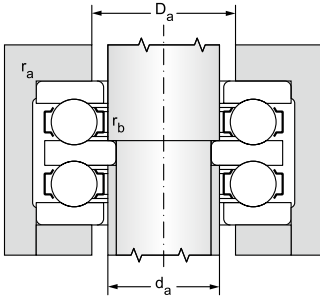

Limiting speed for lubrication with		Bearing designation	Abutment and fillet dimensions					Weight	Coefficient of minimum axial load
grease	oil		d ₂	d _a	D _a	r _a	r _b		
min ⁻¹				max	max	max	max	~	
			mm					kg	
2200	3000	52215**	60	75	89	1	1	1,57	0,27
1600	2100	52315**		75	99	1,5	1	4,83	0,76
2000	2700	52216**	65	80	95	1	1	1,69	0,35
890	1200	52416**		80	117	2	1	14,00	2,7
1900	2500	52217**	70	85	101	1	1	2,34	0,43
1300	1800	52317**		85	111	1,5	1	6,43	1,2
790	1060	52418**		90	131	2	1	19,60	4,1
1100	1500	52318**	75	90	116	1,5	1	6,60	1,5
790	1060	52324**	100	120	157	2	1	17,20	4,1
890	1200	52232**	140	160	186	1,5	1	12,20	3,2



Thrust ball bearings with sphered housing washer $d = 15$ to 130 mm

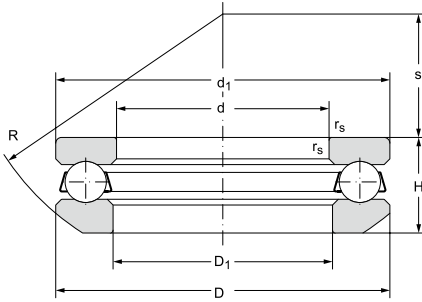

12.7.3

Main dimensions												Basic load rating		
d	D	d ₁	D ₁	D ₂	D ₃	H	H ₁	C	R	s	r _s	d _{min}	C _a	C _{0a}
mm												kN		
15	32	32	17	24	35	13,3	15	4	28	12	0,6		17,3	24,4
17	35	35	19	26	38	13,2	15	4	32	16	0,6		17,8	26,6
20	40	40	22	30	42	14,73	17	5	36	18	0,6		24,5	37,7
25	47	47	27	36	50	16,72	19	5,5	40	19	0,6		30,6	50,5
30	52	52	32	42	55	17,8	20	5,5	45	22	0,6		30,3	58,2
	60	60	32	45	62	22,6	25	7	50	22	1,0		44,8	78,7
35	62	62	37	48	65	19,87	22	7	50	24	1,0		41,8	78,2
	68	68	37	52	72	25,6	28	7,5	56	24	1,0		58,8	105,0
40	68	68	42	55	72	20,3	23	7	56	28,5	1,0		48,4	92,4
	78	78	42	60	82	28,5	31	8,5	64	28	1,0		73,5	135,0
	90	90	42	65	95	38,2	42	12	72	26	1,1		122,1	205,0
45	73	73	47	60	78	21,3	24	7,5	56	26	1,0		47,0	105,0
	85	85	47	65	90	30,13	33	10	64	25	1,0		87,2	164,0
50	78	78	52	62	82	23,49	26	7,5	64	32,5	1,0		51,9	111,0
	90	90	57	72	95	27,35	30	9	72	35	1,0		73,6	159,0
		105	105	57	80	110	39,3	42	11,5	80	30	1,1		122,6
55	120	120	57	88	125	50,5	55	15,5	90	28	1,5		214,2	397,0
60	110	110	62	85	115	38,3	42	11,5	90	41	1,1		125,2	270,0
65	100	100	67	82	105	28,7	32	9	80	40	1,0		76,4	189,0
	115	115	67	90	120	39,4	43	12,5	90	38,5	1,1		129,3	287,0
70	105	105	72	88	110	28,8	32	9	80	38	1,0		76,9	199,0
	125	125	72	98	130	44,2	48	13	100	43	1,1		158,4	340,0
	150	150	73	110	155	63,6	69	19,5	112	34	2,0		272,5	553,0
75	110	110	77	92	115	28,3	32	9,5	90	49	1,0		81,2	209,0
	135	135	77	105	140	48,1	52	15	100	37	1,5		193,2	426,0
80	115	115	82	98	120	29,5	33	10	90	46	1,0		86,4	219,0

d = 15 to 80 mm

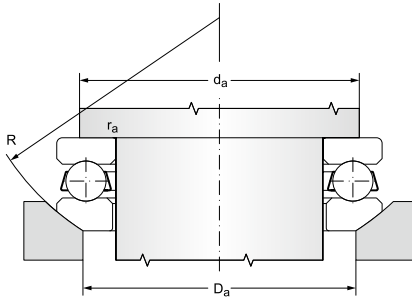

Fatigue load limit	Limiting speed for lubrication with		Designation		Abutment and fillet dimensions			Weight	Minimum axial load factor
	P _u	grease	oil	bearing	sphered housing washer	d _a	D _a	r _a	
kN	min ⁻¹				min	max	max	kg	
					mm				
1,11	6000	7900	53202**	U202	25	24	0,6	0,063	0,004
1,21	5600	7500	53203**	U203	28	26	0,6	0,071	0,004
1,71	5000	6700	53204**	U204	32	30	0,6	0,10	0,008
2,30	4500	6000	53205**	U205	38	36	0,6	0,15	0,015
2,65	4000	5300	53206**	U206	43	42	0,6	0,18	0,018
3,58	3300	4500	53306**	U306	48	45	1,0	0,33	0,030
3,55	3500	4700	53207**	U207	51	48	1,0	0,28	0,032
4,77	2800	3800	53307**	U307	55	52	1,0	0,46	0,050
4,20	3200	4200	53208**	U208	57	55	1,0	0,35	0,047
6,14	2700	3500	53308**	U308	63	60	1,0	0,67	0,095
9,32	2000	2700	53408TNGN**	U408	70	65	1,0	1,35	0,190
4,77	3000	4000	53209**	U209	62	60	1,0	0,39	0,060
7,45	2400	3200	53309**	U309	69	65	1,0	0,83	0,130
5,05	2800	3800	53210**	U210	67	62	1,0	0,47	0,082
7,23	2500	3300	53211**	U211	76	72	1,0	0,75	0,110
11,2	1900	2500	53311**	U311	85	80	1,0	1,68	0,270
18,1	1600	2100	53411**	U411	94	88	1,5	3,08	0,650
12,3	1900	2500	53312**	U312	90	85	1,0	1,71	0,350
8,59	2400	3200	53213**	U213	86	82	1,0	0,91	0,170
13,1	1800	2400	53313**	U313	95	90	1,0	1,89	0,450
9,05	2200	3000	53214**	U214	91	88	1,0	0,97	0,210
15,5	1700	2200	53314**	U314	103	98	1,0	2,50	0,540
24,0	1200	1600	53414**	U414	118	110	2,0	6,40	1,600
9,50	2200	3000	53215**	U215	96	92	1,0	1,00	0,270
18,9	1600	2100	53315**	U315	111	105	1,5	3,20	0,760
9,95	2000	2700	53216**	U216	101	98	1,0	1,10	0,350



Thrust ball bearings with sphered housing washer

d = 85 až 130 mm

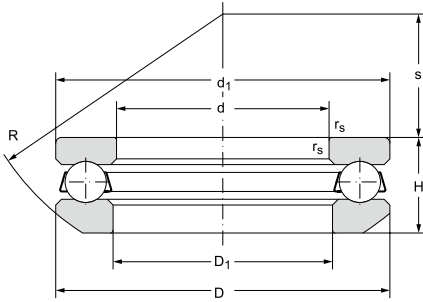

Main dimensions												Basic load rating	
d	D	d ₁	D ₁	D ₂	D ₃	H	H ₁	C	R	s	r _s	dynamic	static
												C _a	C _{0a}
mm												kN	
85	125	125	88	105	130	33,1	37	11	100	52	1,0	104,9	264,0
	150	150	88	115	155	53,1	58	17,5	112	43	1,5	227,5	517,0
90	155	155	93	120	160	54,6	59	18	112	40	1,5	236,6	556,0
	190	187	93	140	195	81,2	88	25,5	140	40	2,1	384,8	970,0
100	170	170	103	135	175	59,2	64	18	125	46	1,5	266,1	628,0
	210	205	103	155	220	90	98	27	160	50	3,0	453,5	1220,0
	210	205	103	155	220	90	98	27	160	50	3,0	453,5	1220,0
110	190	187	113	150	195	67,2	72	20,5	140	51	2,0	323,3	807,0
	190	187	113	150	195	67,2	72	21	140	51	2,0	280,0	744,0
120	210	205	123	165	220	74,1	80	22	160	63	2,1	368,9	977,0
130	190	187	133	160	195	47,9	53	17	140	67	1,5	183,8	537,4

12.7.3

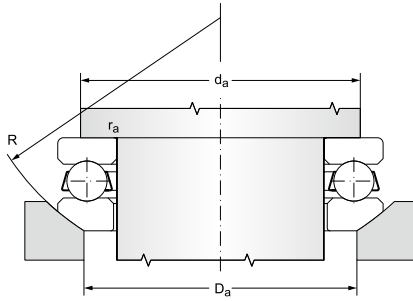

Fatigue load limit	Limiting speed for lubrication with		Designation		Abutment and fillet dimensions			Weight	Minimum axial load factor
	grease	oil	bearing	sphered housing washer	d _a	D _a	r _a	bearing + washer	
P _u					min	max	max		
kN	min ⁻¹				mm			kg	
11,7	2000	2700	53217**	U217	109	105	1,0	1,50	0,430
21,7	1300	1800	53317**	U317	124	115	1,5	4,35	1,200
22,8	1100	1500	53318**	U318	129	120	1,5	4,70	1,500
37,3	790	1060	53418**	U418	133	125	2,0	12,80	4,100
24,6	1060	1400	53320**	U320	142	135	1,5	5,95	2,000
44,5	750	1000	53420 M**	U420	165	155	2,5	18,0	7,700
44,5	750	1000	53420 F**	U420	165	155	2,5	18,0	6,200
30,0	890	1200	53322**	U322	158	150	2,0	8,9	2,800
27,6	890	1200	53322 M	U322	158	150	2,0	9,1	3,100
34,6	790	1060	53324**	U324	173	165	2,0	12,2	4,100
19,3	1170	1600	53226 **	U226	167	160	1,5	4,85	1,700



Double direction thrust ball bearings with sphered housing washers $d = 25$ to 70 mm

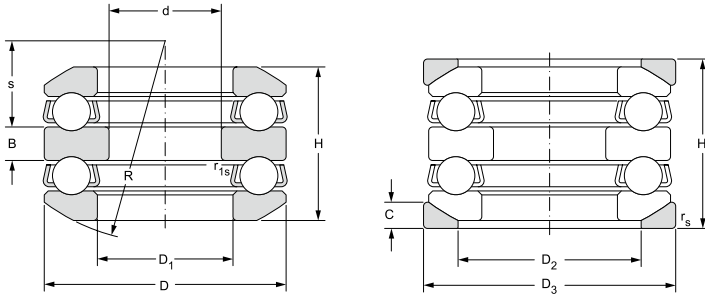

Main Dimensions													Basic load rating	
d	D	D ₁	D ₂	D ₃	H	H ₁	B	C	R	s	r _s	r _{1s}	dynamic	static
													C _a	C _{0a}
mm													kN	
25	60	32	45	62	41,3	46	9	7	50	19,5	1	0,3	44,84	78,7
30	62	37	48	65	37,73	42	8	7	50	21	1	0,3	41,45	78,2
	68	37	52	72	47,19	52	10	7,5	56	21	1	0,3	60,5	105
	68	42	55	72	38,6	44	9	7	56	25	1	0,6	48,4	92,4
	78	42	60	82	54,1	59	12	8,5	64	23,5	1	0,6	74,15	135
35	73	47	60	78	39,6	45	9	7,5	56	23	1	0,6	46,97	105
	85	47	65	90	56,2	62	12	10	64	21	1	0,6	87,2	164
	100	47	72	105	78,9	86	17	12,5	80	23,5	1,1	0,6	141,7	243
45	90	57	72	95	49,6	55	10	9	72	32,5	1	0,6	73,56	159
50	110	62	85	115	70,7	78	15	11,5	90	36,5	1,1	0,6	125,24	270
65	170	83	125	175	128,5	140	27	22	125	30,5	2,1	1	336,02	751
70	150	88	115	155	95,2	105	19	17,5	112	39	1,5	1	243,07	517

12.7.4

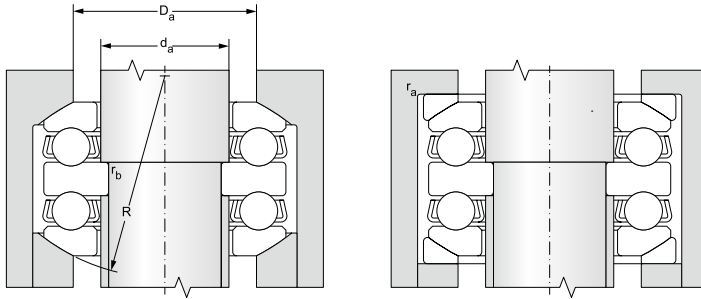

Fatigue load limit	Limiting speed for lubrication with		Designation		Abutment and fillet dimensions					Weight	Minimum axial load factor
	P_u	grease	oil	bearing	sphered housing washer	d	d_a	D_a	r_a		
kN	min ⁻¹				mm					kg	
3,58	3300	4500	54306**	U306	20	30	45	1	0,3	0,58	0,03
3,55	3500	4700	54207**	U207	30	35	48	1	0,3	0,53	0,032
4,77	2800	3800	54307**	U307		35	52	1	0,3	0,85	0,05
4,2	3200	4200	54208**	U208		40	55	1	0,6	0,63	0,047
6,14	2700	3500	54308**	U308		40	60	1	0,6	1,17	0,095
4,77	3000	4000	54209**	U209	35	45	60	1	0,6	0,78	0,06
7,45	2400	3200	54309**	U309		45	65	1	0,6	1,6	0,13
11,05	1900	2500	54409**	U409		45	72	1	0,6	3	0,35
7,23	2500	3300	54211**	U211	45	55	72	1	0,6	1,3	0,11
12,27	1900	2500	54312**	U312	50	60	85	1	0,6	2,9	0,35
31,49	890	1200	54416**	U416	65	80	125	2	1	14	2,7
22,41	1300	1800	54317**	U317	70	85	115	1,5	1	7,95	1,2







12.8 CYLINDRICAL ROLLER THRUST BEARINGS

Design

Cylindrical roller thrust bearings are design for solid and sustainable loadings and resistant to shock stressing. They are standardly offered as single direction bearings that can transfer axial loads only in one direction.

Bearings have a simple shape and can have a single row (fig. 12.8.1) or double row (fig. 12.8.2) design. They are used primarily in heavy-duty loadings, in which thrust ball bearings sometimes fail.

Cylindrical rollers with a modified surface that ensure optimal rolling without edge stressing are installed in the bearings.

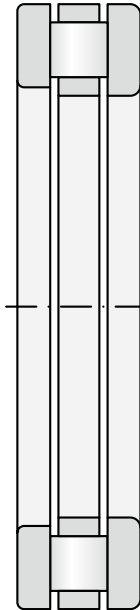

Fig. 12.8.1

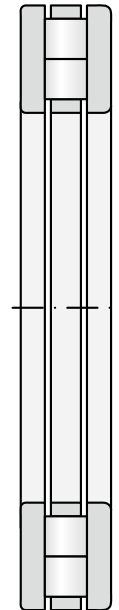

Fig. 12.8.2



Components

Bearing components allow for numerous combinations of bearing designs, where e.g. only a cage with rollers is used and the raceways form individual machine parts (fig. 12.8.3) or a combined loading may be used, when the machine part comprises one raceway and the bearing ring the second part. An independent cage with rollers has the additional marking K, an independent shaft ring WS, and an independent housing ring GS.

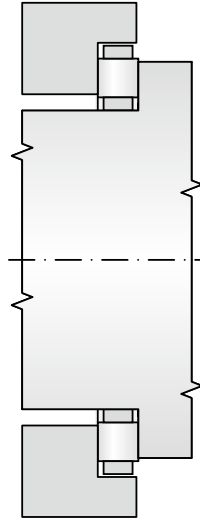

Fig. 12.8.3

Double direction bearings

Bearings can be assembled from housing rings or shaft rings with two cages with rollers and a corresponding centre ring, which is centred on the inner diameter (fig. 12.8.4) or outer (fig. 12.8.5) diameter. The centre ring must be made in the same quality as the respective bearing rings. We recommend consulting ZKL Technical and Consultation Services for more information.

Basic information

Dimensions

Main dimensions of thrust ball bearings conform to ISO 104.

Tolerances

Standard manufacturing of bearings is provided at a normal degree of precision, which is not labelled. Bearings may also be supplied at higher precision P5. Bearing dimension tolerances meet standard ISO 199. These values are provided in tables 7.16a and 7.16b.

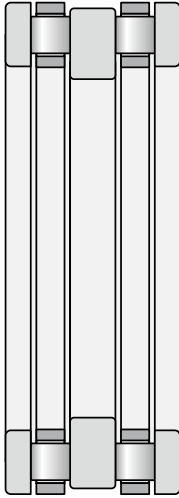

Fig. 12.8.4

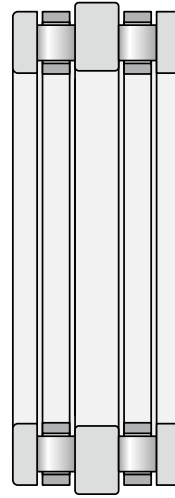

Fig. 12.8.5

Shaft and housing rings and rollers with a cage are manufactured to tolerances specified in tables 12.8.1. and 12.8.2. Rollers in a single cage are from one sorting group and their diameter variance is 1 μm .

Table 12.8.1

Bearing component tolerances		
Bearing components Dimensions		Tolerances
Cage with rollers, K		
Bore diameter	d	E11
Outer diameter	D	a13
Roller diameter	D_w	DIN 5402-1:1993
Shaft ring, WS		
Bore diameter	d	Normal tolerance
Outer diameter	d_1	-
Thickness	B	h11
Axial runout	S_1	Normal tolerance
Tělesový kroužek, GS		
Outer diameter	D	Normal tolerance
Bore diameter	D_1	-
Thickness	B	h11
Axial runout	S_e	Normal tolerance



Table 12.8.2

ISO Tolerances							
Nominal diameter		Tolerance					
d, D		a13		h11		E11	
over	including	max	min	max	min	max	min
mm		µm					
10	18	-290	-560	0	-110	+142	+32
18	30	-300	-630	0	-130	+170	+40
30	40	-310	-700	0	-160	+210	+50
40	50	-320	-710	0	-160	+210	+50
50	65	-340	-800	0	-190	+250	+60
65	80	-360	-820	0	-190	+250	+60
80	100	-380	-920	0	-220	+292	+72
100	120	-410	-950	0	-220	+292	+72
120	140	-460	-1090	0	-250	+335	+85
140	160	-520	-1150	0	-250	+335	+85
160	180	-580	-1210	0	-250	+335	+85
180	200	-660	-1380	0	-290	+390	+100
200	225	-740	-1460	0	-290	+390	+100
225	250	-820	+1540	0	-290	+390	+100
250	280	-920	-1730	0	-320	+430	+110
280	315	-1050	-1860	0	-320	+430	+110
315	355	-1200	-2090	0	-360	+485	+125
355	400	-1350	-2240	0	-360	+485	+125
400	450	-1500	-2470	0	-400	+535	+135
450	500	-1650	-2620	0	-400	+535	+135
500	630	-1900	-3000	0	-440	+585	+145
630	800	-2100	-3350	0	-500	+660	+150

Misalignment

Misalignment between the shaft and the housing is not permitted. Spherical roller thrust bearings do not allow for compensation of such misalignment.

Cages

Thrust ball bearings are equipped with a massive brass cage, additional markings M, MB.

Minimal axial load

A certain minimal load, which ensures reliable operation, must act on thrust ball bearings. Failure to adhere to this load could lead to non-standard rolling off, slippage, and subsequent damage of ring raceways and roller elements.

The minimal requisite load is determined from the equation:

$$F_{a \min} = \left(\frac{C_{0a}}{2000} \right) + M \cdot \left(\frac{n}{1000} \right)^2$$

$F_{a \min}$	minimal load	[kN]
C_0	static bearing capacity	[kN]
M	coefficient of minimum axial load	[see tables]
n	revolutions	[min ⁻¹]

A higher minimal load is required when starting the bearing under low temperatures or when using a high viscosity lubricant. If the minimal load is not derived naturally in the arrangement of the bearing structure, then the bearing must be loaded with an auxiliary force by springs or by the shaft nut.

Bearing equivalent dynamic load capacity

$$P = F_a$$

Bearing equivalent static load capacity

$$P_0 = F_a$$



Additional markings

Additional markings after the basic markings express a particular bearing characteristic:

- K** cage with rollers
- WS** shaft ring
- GS** housing ring
- M** massive brass cage guided on rollers
- MB** massive brass shaft-guided cage

Structure of related components

Perfect resting of rings must be ensured in the developed hub along its entire perimeter and across its breadth. The support surfaces in the hub and on the shaft must be perpendicular to the axis of the shaft. Required dimensional tolerances of loadings for bearings on a shaft and in the hub are listed in table 12.8.3.

Higher speeds necessitate the selection of cage guiding on a shaft, and the shaft guiding surfaces must thus be polished.

Raceways on the shaft and in the hub

Orbits on the shaft and in the hub should have the same hardness and surface quality as bearing raceways. Failure to meet the specified parameters will result in failure to achieve the bearing load capacity parameters.

Table 12.8.3

Shaft and hub bore tolerances			
Bearing component Name	Prefix	Tolerance	
		Shaft	Hub bore
Cage with rollers	K	h8	-
Shaft ring	WS	h8	-
Hub ring	GS	-	H9



Cylindrical roller thrust bearings d = 15 to 630 mm

d = 15 to 80 mm

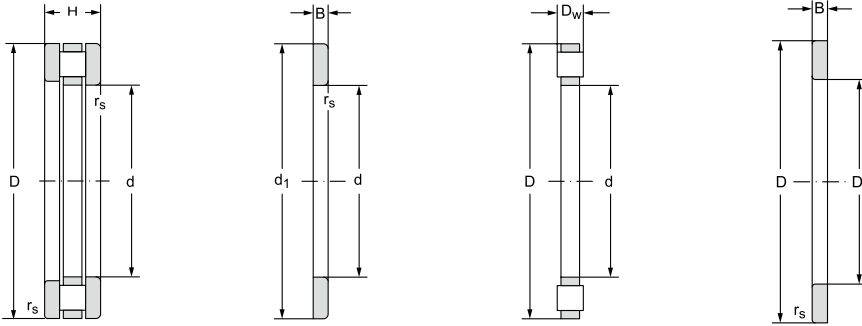

12.8.1

Main dimensions								Basic load rating		Fatigue load limit
d	D	H	d ₁	D ₁	B	D _w	r _s min	dynamic	static	P _u
								C _a	C _{oa}	
mm								kN		kN
15	28	9,0	28,0	16,0	2,75	3,5	0,3	9,3	26,8	3,27
17	30	9,0	30,0	18,0	2,75	3,5	0,3	11,5	30	3,66
20	35	10,0	35,0	21,0	2,75	4,5	0,3	16,9	45	5,47
25	42	11,0	42,0	26,0	3,00	5,0	0,6	23,8	66,5	8,11
30	47	11,0	47,0	32,0	3,00	5,0	0,6	26,1	75,5	9,21
	52	16,0	52,0	32,0	4,25	7,5	0,6	48,9	131	16,00
35	52	12,0	52,0	37,0	3,50	5,0	0,6	27,8	90,5	11,00
	62	18,0	62,0	37,0	5,25	7,5	1,0	60,1	184	22,40
40	60	13,0	60,0	42,0	3,50	6,0	0,6	41,2	135	16,50
	68	19,0	68,0	42,0	5,00	9,0	1,0	82	147	17,90
45	65	14,0	65,0	47,0	4,00	6,0	0,6	43,2	149	18,20
	73	20,0	73,0	47,0	5,50	9,0	1,0	81,3	250	30,50
50	70	14,0	70,0	52,0	4,00	6,0	0,6	44,9	160	19,50
	78	22,0	78,0	52,0	6,50	9,0	1,0	90,1	296	36,10
55	78	16,0	78,0	57,0	5,00	6,0	0,6	66,9	281	34,30
	90	25,0	90,0	57,0	7,00	11,0	1,0	120	379	46,20
60	85	17,0	85,0	62,0	4,75	7,5	1,0	77,9	294	35,90
	95	26,0	95,0	62,0	7,50	11,0	1,0	134	458	55,90
65	90	18,0	90,0	67,0	5,25	7,5	1,0	81,7	314	38,30
	100	27,0	100,0	67,0	8,00	11,0	1,0	137	481	58,70
70	95	18,0	95,0	72,0	5,25	7,5	1,0	84,7	340	41,50
	105	27,0	105,0	72,0	8,00	11,0	1,0	144	519	63,30
75	100	19,0	100,0	77,0	5,75	7,5	1,0	82	331	40,40
	110	27,0	110,0	77,0	8,00	11,0	1,0	134	482	58,80
80	105	19,0	105,0	82,0	5,75	7,5	1,0	79,1	328	40,00
	115	28,0	115,0	82,0	8,50	11,0	1,0	149	602	73,40

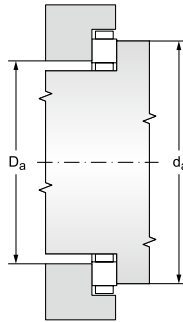
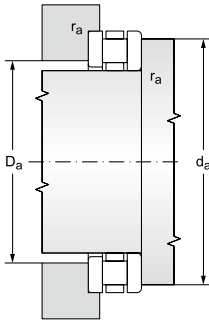

Limiting speed for lubrication with		Bearing designation	Abutment and fillet dimensions				Weight	Bearing component designation			Min. axial load factor
grease	oil		d	d _a	D _a	r _a		~	Cage with rollers	Shaft ring	
min ⁻¹			mm			kg				M	
3200	4300	81102	15	27	16	0,3	0,023	K 81102	WS 81102	GS 81102	0,00006
3200	4300	81103	17	29	18	0,3	0,027	K 81103	WS 81103	GS 81103	0,00008
2800	3800	81104	20	34	21	0,3	0,037	K 81104	WS 81104	GS 81104	0,00019
2200	3200	81105	25	41	26	0,6	0,053	K 81105	WS 81105	GS 81105	0,0004
2000	3000	81106	30	46	31	0,6	0,057	K 81106	WS 81106	GS 81106	0,0005
1700	2400	81206	30	50	31	0,6	0,12	K 81206	WS 81206	GS 81206	0,0014
1900	2800	81107	35	51	36	0,6	0,073	K 81107	WS 81107	GS 81107	0,0007
1500	2000	81207	35	58	39	1,0	0,20	K 81207	WS 81207	GS 81207	0,003
1700	2400	81108	40	58	42	0,6	0,11	K 81108	WS 81108	GS 81108	0,0016
1400	1900	81208	40	66	43	1,0	0,25	K 81208	WS 81208	GS 81208	0,0053
1600	2200	81109	45	63	47	0,6	0,13	K 81109	WS 81109	GS 81109	0,002
1300	1800	81209	45	70	48	1,0	0,29	K 81209	WS 81209	GS 81209	0,0059
1600	2100	81110	50	68	52	0,6	0,14	K 81110	WS 81110	GS 81110	0,0023
1200	1700	81210	50	75	53	1,0	0,36	K 81210	WS 81210	GS 81210	0,0072
1400	1900	81111	55	77	56	0,6	0,22	K 81111	WS 81111	GS 81111	0,0068
950	1400	81211	55	85	59	1,0	0,57	K 81211	WS 81211	GS 81211	0,013
1200	1800	81112	60	82	62	1,0	0,28	K 81112	WS 81112	GS 81112	0,0075
900	1350	81212	60	91	64	1,0	0,65	K 81212	WS 81212	GS 81212	0,018
1200	1700	81113	65	87	67	1,0	0,31	K 81113	WS 81113	GS 81113	0,0083
900	1300	81213	65	96	69	1,0	0,73	K 81213	WS 81213	GS 81213	0,020
1150	1650	81114	70	92	72	1,0	0,34	K 81114	WS 81114	GS 81114	0,0098
870	1250	81214	70	102	74	1,0	0,78	K 81214	WS 81214	GS 81214	0,023
1100	1600	81115	75	97	78	1,0	0,40	K 81115	WS 81115	GS 81115	0,0068
850	1200	81215	75	106	79	1,0	0,80	K 81215	WS 81215	GS 81215	0,015
1000	1500	81116	80	102	83	1,0	0,41	K 81116	WS 81116	GS 81116	0,0074
830	1150	81216	80	112	84	1,0	0,92	K 81216	WS 81216	GS 81216	0,029



Cylindrical roller thrust bearings

d = 85 to 220 mm

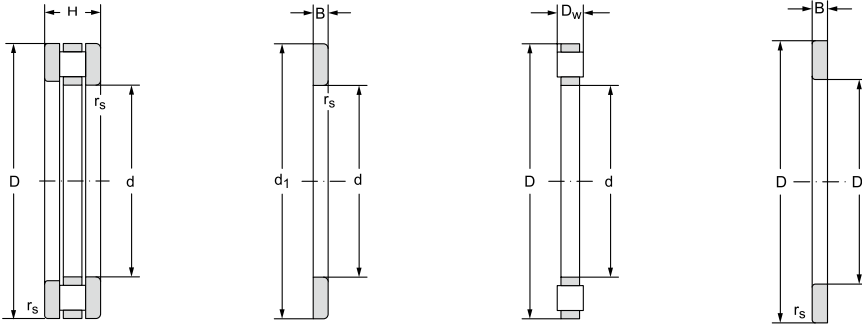

12.8.1

Main dimensions								Basic load rating		Fatigue load limit
d	D	H	d ₁	D ₁	B	D _w	r _s	dynamic	static	P _u
								C _a	C _{oa}	
mm								kN		kN
85	110	19,0	110,0	87,0	5,75	7,5	1,0	86	360	44,00
	125	31,0	125,0	88,0	9,50	12,0	1,0	166	624	76,00
90	120	22,0	120,0	92,0	6,50	9,0	1,0	102	444	53,40
	135	35,0	135,0	93,0	10,50	14,0	1,1	231	860	101,00
100	135	25,0	135,0	102,0	7,00	11,0	1,0	152	605	70,30
	150	38,0	150,0	103,0	11,50	15,0	1,1	255	1010	115,00
110	145	25,0	145,0	112,0	7,0	11,0	1,0	160	670	76,00
	160	38,0	160,0	113,0	11,5	15,0	1,1	255	988	110,00
120	155	25,0	155,0	122,0	7,0	11,0	1,0	167	729	80,80
	170	39,0	170,0	123,0	12,0	15,0	1,1	260	1020	111,00
130	170	30,0	170,0	132,0	9,0	12,0	1,0	189	865	93,40
	190	45,0	187,0	133,0	13,0	19,0	1,5	371	1390	147,00
140	180	31,0	178,0	142,0	9,5	12,0	1,0	201	920	97,40
	200	46,0	197,0	143,0	13,5	19,0	1,5	349	1300	135,00
150	190	31,0	188,0	152,0	9,5	12,0	1,0	210	980	102,00
	215	50,0	212,0	153,0	14,5	21,0	1,5	457	1840	187,00
160	200	31,0	198,0	162,0	9,5	12,0	1,0	202	980	100,00
	225	51,0	222,0	163,0	15,0	21,0	1,5	477	1900	190,00
170	215	34,0	213,0	172,0	10,0	14,0	1,1	282	1330	133,00
	240	55,0	237,0	173,0	16,5	22,0	1,5	529	2190	215,00
180	225	34,0	222,0	183,0	10,0	14,0	1,1	264	1210	119,00
	250	56,0	247,0	183,0	17,0	22,0	1,5	549	2390	232,00
190	240	37,0	237,0	193,0	11,0	15,0	1,1	302	1360	132,00
	270	62,0	267,0	194,0	18,0	26,0	2,0	691	2880	274,00
200	250	37,0	247,0	203,0	11,0	15,0	1,1	303	1470	141,00
	280	62,0	277,0	204,0	18,0	26,0	2,0	711	3050	286,00
220	270	37,0	267,0	223,0	11,0	15,0	1,1	329	1670	156,00
	300	62,0	297,0	224,0	18,5	26,0	2,0	738	3230	296,00

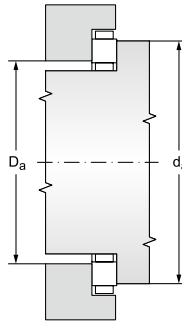
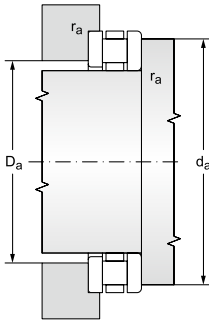

Limiting speed for lubrication with		Bearing designation	Abutment and fillet dimensions				Weight	Bearing component designation			Min. axial load factor
grease	oil		d	d _a	D _a	r _a		~	Cage with rollers	Shaft ring	
min ⁻¹			mm			kg					
950	1500	81117	85	108	87	1,0	0,42	K 81117	WS 81117	GS 81117	0,012
800	1100	81217	85	119	90	1,0	1,26	K 81217	WS 81217	GS 81217	0,025
900	1300	81118	90	117	93	1,0	0,63	K 81118	WS 81118	GS 81118	0,014
750	1000	81218	90	129	95	1,0	1,75	K 81218	WS 81218	GS 81218	0,061
850	1200	81120	100	131	104	1,0	0,94	K 81120	WS 81120	GS 81120	0,028
670	900	81220	100	142	107	1,0	2,15	K 81220	WS 81220	GS 81220	0,056
800	1100	81122M	110	141	114	1,0	1,04	K 81122M	WS 81122	GS 81122	0,031
630	850	81222M	110	152	117	1,0	2,28	K 81222M	WS 81222	GS 81222	0,068
750	1050	81124M	120	151	124	1,0	1,10	K 81124M	WS 81124	GS 81124	0,038
530	800	81224M	120	162	127	1,0	2,55	K 81224M	WS 81224	GS 81224	0,076
700	950	81126M	130	165	135	1,0	2,72	K 81126M	WS 81126	GS 81126	0,049
530	700	81226M	130	181	137	1,5	4,30	K 81226M	WS 81226	GS 81226	0,170
670	900	81128M	140	175	145	1,0	2,05	K 81128M	WS 81128	GS 81128	0,059
530	650	81228M	140	191	147	1,5	4,61	K 81228M	WS 81228	GS 81228	0,162
530	850	81130M	150	185	155	1,0	2,10	K 81130M	WS 81130	GS 81130	0,067
480	630	81230M	150	211	158	1,5	6,04	K 81230M	WS 81230	GS 81230	0,300
630	830	81132M	160	195	165	1,0	2,23	K 81132M	WS 81132	GS 81132	0,085
450	600	81232M	160	220	168	1,5	6,27	K 81232M	WS 81232	GS 81232	0,330
600	800	81134M	170	209	176	1,0	2,98	K 81134M	WS 81134	GS 81134	0,110
430	560	81234M	170	235	180	1,5	7,80	K 81234M	WS 81234	GS 81234	0,430
560	750	81136M	180	219	185	1,0	3,10	K 81136M	WS 81136	GS 81136	0,130
410	540	81236M	180	245	190	1,5	8,35	K 81236M	WS 81236	GS 81236	0,470
530	700	81138M	190	233	197	1,0	3,90	K 81138M	WS 81138	GS 81138	0,170
380	500	81238M	190	265	200	2,0	10,6	K 81238M	WS 81238	GS 81238	0,680
510	680	81140M	200	243	206	1,0	4,10	K 81140M	WS 81140	GS 81140	0,190
370	490	81240M	200	275	210	2,0	12,2	K 81240M	WS 81240	GS 81240	0,790
500	670	81144M	220	263	226	1,0	4,60	K 81144M	WS 81144	GS 81144	0,240
360	480	81244M	220	296	230	2,0	13,4	K 81244M	WS 81244	GS 81244	0,910



Cylindrical roller thrust bearings

d = 240 to 630 mm

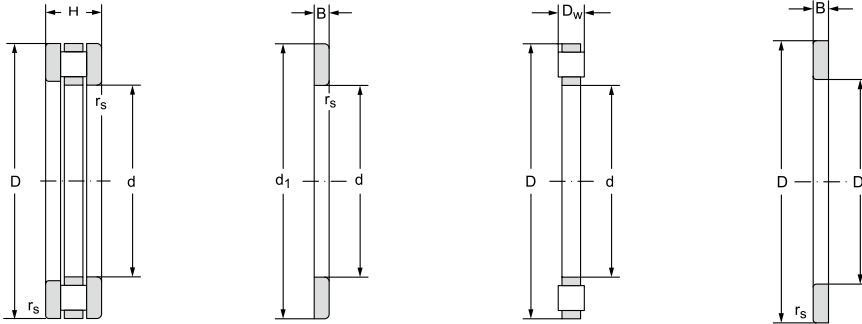

12.8.1

Main dimensions								Basic load rating		Fatigue load limit
d	D	H	d ₁	D ₁	B	D _w	r _s	dynamic	static	P _u
								C _a	C _{0a}	
mm								kN		kN
240	300	45,0	297,0	243,0	13,5	18,0	1,5	368	2400	217,00
	340	78,0	335,0	244,0	23,0	32,0	2,1	1070	4850	430,00
260	320	45,0	317,0	263,0	13,5	18,0	1,5	488	2650	235,00
	360	79,0	355,0	264,0	23,5	32,0	2,1	1090	5200	452,00
280	350	53,0	347,0	283,0	15,5	22,0	1,5	672	3440	297,00
	380	80,0	375,0	284,0	24,0	32,0	2,0	1150	5510	470,00
300	380	62,0	376,0	304,0	18,5	25,0	2,0	851	4400	372,00
	420	95,0	415,0	304,0	28,5	38,0	3,0	1520	7210	599,00
320	400	63,0	396,0	324,0	19,0	25,0	2,0	878	4590	381,00
	420	95,0	435,0	325,0	28,5	38,0	3,0	1550	7480	616,00
340	420	64,0	416,0	344,0	19,5	25,0	2,0	871	4730	386,00
	460	96,0	455,0	345,0	29,0	38,0	3,0	1580	7890	635,00
360	440	65,0	436,0	364,0	20,0	25,0	2,0	885	4830	389,00
	500	110,0	495,0	365,0	32,5	45,0	4,0	2050	9900	779,00
380	460	65,0	456,0	384,0	20,0	25,0	2,0	915	5100	404,00
400	480	65,0	476,0	404,0	20,0	25,0	2,0	950	5370	420,00
420	500	65,0	495,0	424,0	20,0	25,0	2,0	985	5630	434,00
440	540	80,0	535,0	444,0	24,0	32,0	2,1	1370	7810	591,00
460	560	80,0	555,0	464,0	24,0	32,0	2,1	1400	8020	600,00
480	580	80,0	575,0	484,0	24,0	32,0	2,1	1460	8460	626,00
500	600	80,0	595,0	505,0	24,0	32,0	2,1	1490	8670	634,00
530	640	85,0	635,0	535,0	25,5	34,0	3,0	1670	10000	718,00
560	670	85,0	665,0	565,0	25,5	34,0	3,0	1760	10600	750,00
600	710	85,0	705,0	605,0	25,5	34,0	3,0	1850	11300	784,00
630	750	85,0	746,0	634,0	25,5	38,0	3,0	2160	13200	902,00

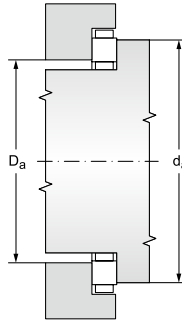
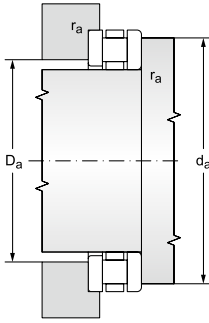

Limiting speed for lubrication with		Bearing designation	Abutment and fillet dimensions				Weight	Bearing component designation			Min. axial load factor
grease	oil		d	d _a	D _a	r _a		~	Cage with rollers	Shaft ring	
min ⁻¹			mm			kg					
430	560	81148M	240	296	248	1,5	7,35	K 81148M	WS 81148	GS 81148	0,500
300	400	81248M	240	335	261	2,0	22,1	K 81248M	WS 81248	GS 81248	1,900
400	530	81152M	260	316	268	1,5	7,90	K 81152M	WS 81152	GS 81152	0,560
280	380	81252M	260	353	280	2,0	24,1	K 81252M	WS 81252	GS 81252	2,300
360	480	81156M	280	346	288	1,5	10,5	K 81156M	WS 81156	GS 81156	1,100
260	360	81256M	280	373	300	2,0	26,1	K 81256M	WS 81256	GS 81256	2,400
320	430	81160M	300	373	315	2,0	16,4	K 81160M	WS 81160	GS 81160	1,500
220	320	81260M	300	413	328	2,5	40,3	K 81260M	WS 81260	GS 81260	4,200
300	400	81164M	320	394	334	2,0	18,0	K 81164M	WS 81164	GS 81164	1,900
200	300	81264M	320	434	348	2,5	42,6	K 81264M	WS 81264	GS 81264	4,800
280	380	81168M	340	414	354	2,0	19,4	K 81168M	WS 81168	GS 81168	2,000
200	280	81268M	340	452	367	2,5	46,9	K 81268M	WS 81268	GS 81268	5,300
270	370	81172M	360	434	374	2,0	19,4	K 81172M	WS 81172	GS 81172	2,100
180	260	81272M	360	492	393	3,0	65,3	K 81272M	WS 81272	GS 81272	8,800
260	360	81176M	380	453	393	2,0	23,5	K 81176M	WS 81176	GS 81176	2,20
250	350	81180M	400	473	413	2,0	24,3	K 81180M	WS 81180	GS 81180	2,60
240	340	81184M**	420	493	433	2,0	27,0	K 81184M	WS 81184	GS 81184	2,80
210	310	81188M**	440	533	459	2,0	41,6	K 81188M	WS 81188	GS 81188	5,30
200	300	81192M**	460	553	479	2,0	44,0	K 81192M	WS 81192	GS 81192	5,80
190	280	81196M**	480	583	500	2,0	47,3	K 81196M	WS 81196	GS 81196	6,10
180	270	811/500M**	500	592	519	2,0	49,8	K 811/500M	WS 811/500	GS 811/500	7,10
180	260	811/530M**	530	632	554	2,5	59,1	K 811/530M	WS 811/530	GS 811/530	9,20
170	260	811/560M**	560	662	584	2,5	62,3	K 811/560M	WS 811/560	GS 811/560	9,90
170	240	811/600M**	600	702	624	2,5	34,1	K 811/600M	WS 811/600	GS 811/600	12,00
160	220	811/630M**	630	732	650	2,5	82,3	K 811/630M	WS 811/630	GS 811/630	17,00







ZKL 29320EJ CZECH OGeL



12.9 SPHERICAL ROLLER THRUST BEARINGS

Spherical roller thrust bearings have a large number of asymmetrical spherical rollers with good adhesion to shaft and housing rings, making them suitable for capturing large axial loads as well as certain radial loads at relatively high speeds. Bearings are detachable, which can be utilized during installation. Bearings are manufactured with a pressed steel-sheet cage, which forms an integral unit with the shaft ring and spherical rollers. In addition, ZKL also manufactures bearings with a massive cage. A massive brass cage is guided by the sleeve fastened in the shaft ring bore and together also form an integral unit. The internal bearing design with massive cage requires oil lubrication. In other cases, the bearings may also be lubricated with greases – preferably with EP additives. In such cases, a sufficient amount of lubricant must be supplied into contact with the spherical roller faces and the guide flanges. Both variants of the structural design are illustrated in figure 12.9.1.

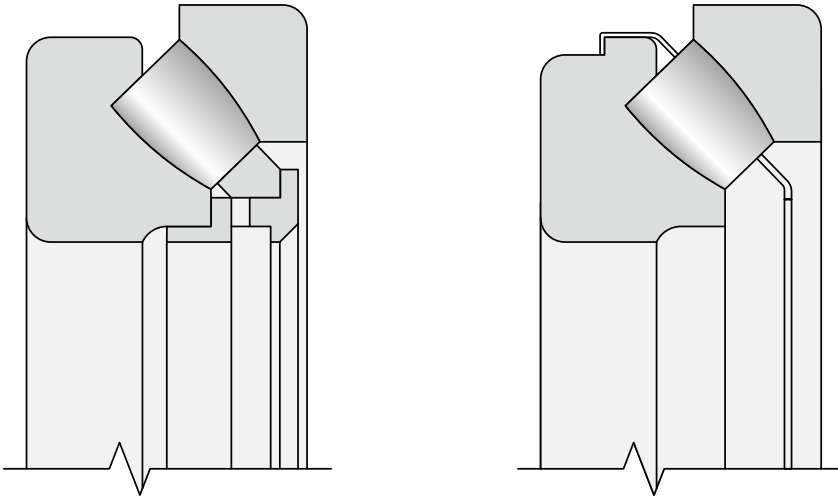

Fig. 12.9.1



Main dimensions

The main dimensions of bearings are consistent with standard ISO 104 and are listed for individual bearings in the tables of the publication.

Labelling

Labelling of standard bearings is specified in the tables of the publication. Divergence from the standard design is marked by additional characters specified in the catalogue introduction.

- J. Bearing with cage made from steel sheeting
- EJ. Optimized internal design with steel cage
- M. Bearing with massive brass cage
- EM. Optimized internal design with massive brass cage
- EF. Optimized internal design with massive steel cage

Cage

Spherical roller thrust bearings in "M" and "EM" versions have brass cages guided by the steel sleeve on the shaft ring. "EF" design is identical to "EM"; the cage material is steel. "J" version bearings have a steel-sheet cage guided on a shaft ring. "J" -version bearings are interchangeable with bearings with a massive brass cage. If a bearing with a massive brass cage is to be substituted in a loading, where the shaft ring is supported on the shaft by the steel sleeve face that guides the cage by a bearing designed with a sheet-metal cage, then a spacing ring must be inserted between the shaft ring and the original fitting on the shaft – see figure 12.9.2. When replacing bearings of older designs or from a different manufacturer, the dimensions of the spacing ring must also be checked or machined to the dimension needed (fig. 12.9.3). The recommended outer ring diameter is specified in the tables. The ring must be tempered and the faces must be precisely grinded.

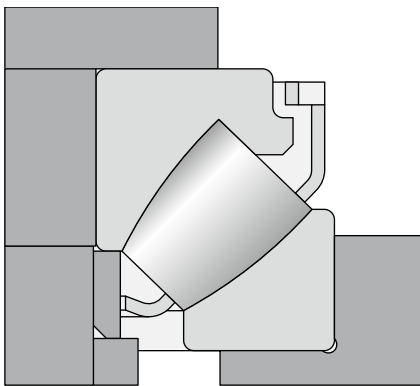

Fig. 12.9.2

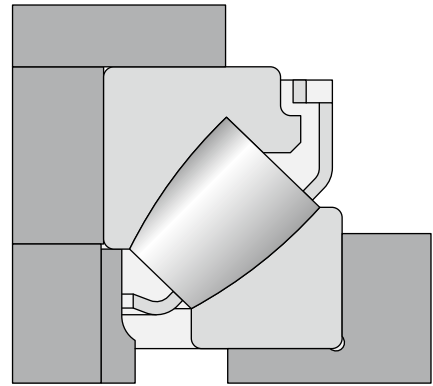

Fig. 12.9.3

Precision

Bearings are currently produced at a normal degree of precision P0, which is not marked. The dimensional and operational precision tolerances are listed in table 7.16.

Self-alignment ability

The spherical raceway of the bearing housing ring during regular operating conditions ($F_a \leq 0.1C_a$) enables self-alignment from the centre position without interfering with the proper bearing function by the values specified in the table.

Table 12.9.1

Bearing type	Permissible misalignment
292	2°
293	2°30'
294	3°

Loading structure

The connecting dimensions, specified in the tables of the publication, are suitable for bearings, where the load $F_a = 0.1C_a$. Bearing rings should be supported along their entire faces during greater loads, i.e. $d_a = d_1$ and $D_a = D_1$.

When using bearings with a sheet-metal cage, we recommend enlarging the hub bore near the cage by 20 mm to prevent any shaft onset from coming into contact with the cage (fig. 12.9.4).

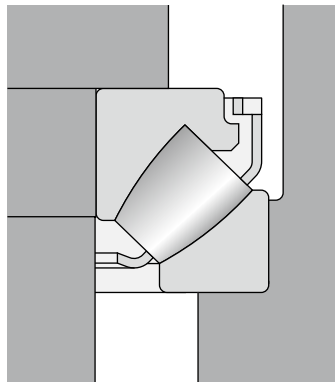

Fig. 12.9.4





Axial equivalent dynamic load

$$P_a = F_a + 1,2F_r \quad (F_r \leq 0,55F_a) \quad [\text{kN}]$$

Axial equivalent static load

$$P_{oa} = F_a + 2,7F_r \quad (F_r \leq 0,55F_a) \quad [\text{kN}]$$

The static safety coefficient for Spherical roller thrust bearings must be $S_0 \geq 4$.

Minimal axial load

Higher rotation speeds in spherical roller thrust bearings present a risk of rolling elements sliding between the raceways due to the centrifugal forces in cases, when the axial load F_a falls below the permissible value. The following relationship is used for calculating the $F_{a \min}$ value:

when $1,8F_r < 0,0005 C_0$

$$F_{a \min} = 0,0005 C_0 + M (0,001n)^2$$

otherwise

$$F_{a \min} = 1,8F_r + M (0,001n)^2$$

$F_{a \min}$ minimal axial load [kN]

F_r radial load [kN]

C_{oa} axial static load rating [kN]

. (values are provided in the tables of the publication)

n rotating speed [min⁻¹]

M coefficient of minimum axial load

. (values are provided in the tables of the publication)

If the external axial load of the bearing is too small or if the bearing is unloaded during operation, e.g. in bearing pairs, then an axial load must be created, e.g. by the use of springs. If a radial load is simultaneously acting, the following condition must be met: $F_r \leq 0,55F_a$.



Spherical roller thrust bearings d = 50 to 1120 mm

d = 50 to 130 mm

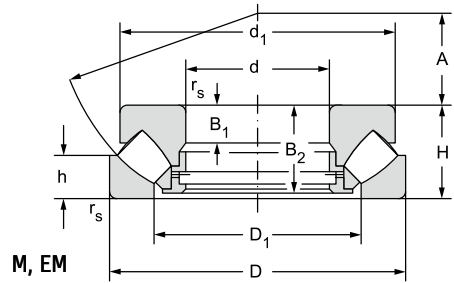
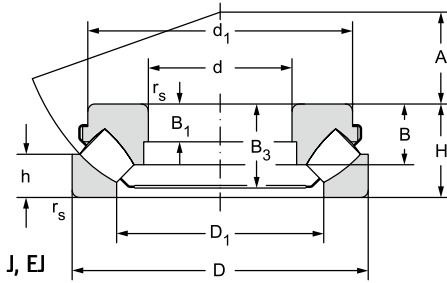

12.9.1

Main dimensions												Basic load rating	
d	D	H	d ₁	D ₁	B	B ₁	B ₂	B ₃	h	A	r _s	dynamic	static
mm												C _a	C _{0a}
												kN	
50	110	36	95,0	70,0	25	13		32,0	20,5	32	1,5	299	930
60	130	42	118,0	88,0	28	15	39,5	35,5	20,0	38	1,5	287	809
	130	42	112,3	87,0	27	27		37,0	20,0	38	1,2	345	951
65	140	45	128,0	96,5	28	16	42,5	38,0	21,0	42	2,0	340	973
	140	45	122,8	93,0	29,5	16		39,0	21,0	42	2,0	417	1155
70	150	48	137,0	102,0	32	17	45,5		23,0	44	2,0	371	1070
	150	48	131,6	105,0	31	17		43,5	23,0	44	2,0	453	1280
75	160	51	146,0	109,0	34,5	18	48,0		24,0	47	2,0	429	1250
	160	51	141,8	108,0	33,5	18		47,0	24,0	47	2,0	527	1500
80	170	54	155,0	116,0	36	19	51,0		24,0	50	2,1	464	1370
	170	54	150,8	116,0	36	19		46,5	24,0	50	2,1	625	1640
85	180	58	164,0	125,0	38	21	55,0		28,0	54	2,1	527	1570
	180	58	164,0	123,0	37	21		50,0	28,0	54	2,1	713	1945
90	190	60	174,0	130,0		22	57,0		29,0	56	2,1	578	1780
	190	60	170,8	130,0		22	57,0		29,0	56	2,1	724	2172
100	170	42	150,0	128,0	26,2	15		37,3	20,5	58	1,5	449	1400
	210	67	193,0	144,5		24	64,0		32,0	62	3,0	705	2170
	210	67	189,8	144,0		24	64,0		32,0	62	2,5	891	2578
110	190	48	176,0	143,0		16	45,5		23,0	64	2,0	442	1420
	190	48	176,0	143,0	31	16		42,0	23,0	64	2,0	587	1760
	230	73	212,0	160,0		26	69,0		35,0	69	3,0	817	2600
	230	73	209,5	159,0		27			35,0	69	2,5	1053	3078
120	210	54	194,0	157,5		18	51,0		26,0	70	2,1	577	1830
	210	54	187,1	155,5	35,5	19		47,0	27,0	70	2,1	670	2100
	250	78	229,0	172,0		29	74,0		37,0	74	4,0	934	3000
	250	78	226,8	173,0		29			37,0	74	4,0	1215	3590
130	225	58	205,0	170,0	37	19	55,0		28,0	76	2,1	647	2070
	225	58	201,5	165,7		21		49,6	30,1	76	2,1	788	2950
	270	85	247,0	188,0	55,5	31	81,0		41,0	81	4,0	1090	3540
	270	85	245,0	188,0		31			41,0	81	4,0	1437	4300

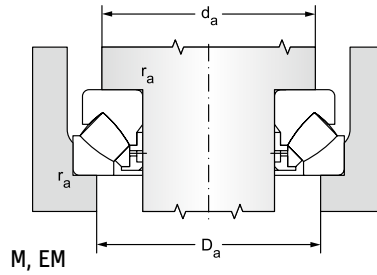
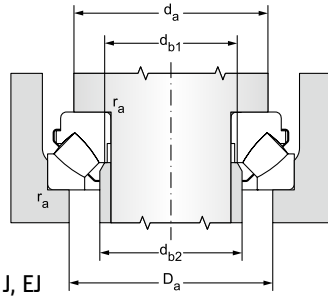

Deliveries of bearings marked * must be first consulted with the manufacturer, ** NEW FORCE

Fatigue load limit	Limiting speed for lubrication with	Bearing designation	Abutment and fillet dimensions						Weight	Minimum axial load factor
			d	d _a	d _{b1}	D _a	d _{b2}	r _a		
P _v	oil			min	max	max	max	max	-	
kN	min ⁻¹		mm						kg	
110	3100	29410EJ**	50	70	55,8	90	59,5	1,5	1,67	0,11
99	2400	29412M*	60	90		109		1,5	2,60	0,08
120	2600	29412EJ**		90	67,0	117	67	1,5	2,47	0,11
120	2200	29413M*	65	100		118		2,0	3,30	0,12
140	2400	29413EJ**		100	72,0	118	72	2,0	3,26	0,17
130	2000	29414M*	70	105		126		2,0	4,00	0,14
160	2200	29414EJ**		105	77,5	126	77,5	2,0	3,98	0,2
150	2000	29415M*	75	115		134		2,0	4,90	0,2
180	2200	29415EJ**		115	82,5	134	82,5	2,0	4,90	0,28
170	1900	29416M*	80	120		141		2,0	5,80	0,23
200	2000	29416EJ**		120	88,0	141	88	2,0	5,80	0,34
190	1800	29417M*	85	130		153		2,0	6,90	0,31
240	1800	29417EJ**		130	94,0	153	94	2,0	6,67	0,47
220	1700	29418M*	90	135		161		2,0	8,10	0,4
260	1800	29418EJ**		135	99,0	161	99	2,0	8,10	0,59
170	2000	29320EJ**	100	130	107,0	147	107	1,5	3,95	0,25
260	1500	29420M*		150		178		2,5	11,8	0,59
310	1600	29420EJ**		150	110,0	175	110	3,0	10,8	0,83
150	1600	29322M*	110	145		165		2,0	5,50	0,25
190	1600	29322EJ**		145	117,0	165	117	2,0	5,40	0,39
270	1400	29422M*		165		196		2,5	14,5	0,85
320	1400	29422EJ**		165	120,5	193	129	2,5	13,5	1,2
190	1400	29324M**	120	160		184		2,0	7,60	0,42
220	1600	29324EJ**		160	128,0	181	128	2,0	7,41	0,55
300	1300	29424M*		180		212		3,0	18,1	1,1
360	1300	29424EJ**		180	132,0	209	140	3,0	17,5	1,6
210	1300	29326M**	130	170		198		2,0	9,30	0,54
300	1500	29326EJ**		175	138,0	194	143	2,0	9,08	1,1
350	1200	29426M*		195		229		3,0	22,5	1,6
430	1200	29426EJ**		195	142,5	227	153	3,0	21,6	2,3



Spherical roller thrust bearings

d = 140 to 220 mm

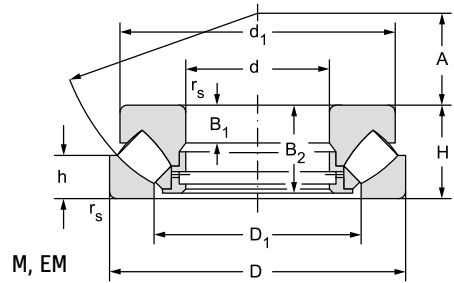
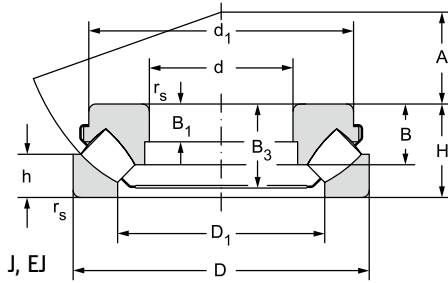

12.9.1

Main dimensions												Basic load rating	
d	D	H	d ₁	D ₁	B	B ₁	B ₂	B ₃	h	A	r _s	dynamic	static
mm												C _a	C _{0a}
												kN	
140	240	60	219,0	183,0		20	57,0		29,0	82	2,1	695	2310
	240	60	214,9	178,9	38,5	22		52,4	30,0	82	2,1	876	3150
	280	85	257,0	197,5		31	81,0		41,0	86	4,0	1164	3750
	280	85	254,0	196,5	54	32		74,0	41,0	86	4,0	1554	4686
150	250	60	229,0	193,0		20	57,0		29,0	87	2,1	718	2430
	250	60	222,5	189,6	38	22		53,8	28,0	87	2,1	889	3236
	300	90	276,0	211,5		32	86,0		44,0	92	4,0	1318	4270
	300	90	273,0	209,5	58	34		79,0	44,0	92	4,0	1675	5241
160	270	67	248,0	207,0		23	64,0		32,0	92	3,0	831	2810
	270	67	243,6	202,3	42	24		58,6	33,0	92	3,0	1067	3977
	320	95	306,0	226,0		34	91,0		45,0	99	5,0	1504	4810
	320	95	282,8	221,7	60,5	35		82,0	45,5	99	5,0	1854	5930
170	280	67	258,0	215,0		23	64,0		32,0	96	3,0	858	2950
	280	67	253,6	214,6	42,2	24		60,0	32,0	96	3,0	1090	4098
	340	103	324,0	240,0		37	99,0		50,0	104	5,0	1669	5380
	340	103	301,0	236,0	65,5	36		88,0	50,0	104	5,0	2029	6230
180	300	73	277,0	231,0		25	69,0		35,0	103	3,0	1014	3530
	300	73	270,4	228,3	46	26		64,3	35,5	103	3,0	1280	4813
	360	109	342,0	255,0		39	105,0		52,0	110	5,0	1854	6010
	360	109	320,6	248,7	69,5	38		93,0	53,0	110	5,0	2297	7160
190	320	78	294,0	246,0		27	74,0		38,0	110	4,0	1120	4010
	320	78	284,4	239,5	49	28		68,0	36,0	110	4,0	1483	4840
	380	115	360,0	270,0		41	111,0		55,0	117	5,0	2019	6610
	380	115	339,2	263,0	73	41		98,0	55,5	117	5,0	2493	7750
200	280	48	264,0	233,0	32	17	45,0		24,0	108	2,1	731	3150
	340	85	325,0	261,0		29	81,0		41,0	116	4,0	1300	4740
	340	85	302,8	253,6	53,5	29		73,0	40,0	116	4,0	1669	5480
	400	122	365,0	284,0		43	117,0		59,0	122	5,0	2210	7510
	400	122	355,7	276,5	77	43		104,0	59,4	122	5,0	2791	8790
220	300	48	286,0	252,0		17	46,0		24,0	117	2,0	757	3350
	360	85	345,0	280,0		29	81,0		41,0	125	4,0	1340	4970
	360	85	324,4	273,0	55	29		74,0	41,0	125	4,0	1792	6300
	420	122	400,0	305,0		43	117,0		58,0	132	6,0	2328	7970
	420	122	375,3	296,0	77	44		103,0	58,5	132	6,0	2905	9070

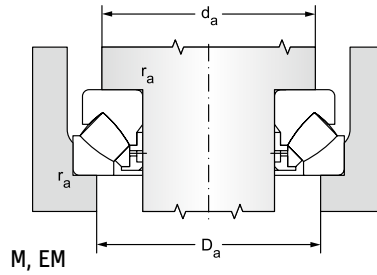
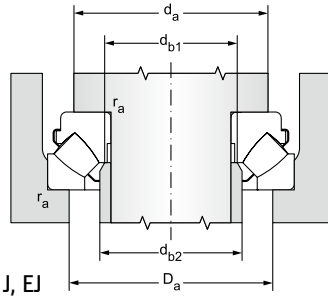

Deliveries of bearings marked * must be first consulted with the manufacturer, ** NEW FORCE

Fatigue load limit	Limiting speed for lubrication with	Bearing designation	Abutment and fillet dimensions						Weight	Minimum axial load factor
			d	d _a	d _{b1}	D _a	d _{b2}	r _a		
P _v	oil			min	max	max	max	max	-	
kN	min ⁻¹		mm						kg	
230	1300	29328M**	140	185		211		2,0	11,0	0,67
320	1400	29328EJ**		185	148,0	208	154	2,0	10,5	1,2
370	1200	29428M**		205		239		3,0	24,2	1,8
460	1200	29428EJ**		205	153,0	239	162	3,0	23,0	2,7
240	1200	29330M**	150	195		222		2,0	11,5	0,74
320	1400	29330EJ**		195	158,0	219	163	2,0	10,9	1,3
410	1100	29430M**		220		257		3,0	29,4	2,3
500	1100	29430EJ**		220	163,0	275	175	3,0	28,2	3,4
270	1100	29332M**	160	210		239		2,5	15,2	0,99
390	1200	29332EJ**		210	169,0	235	176	2,5	14,4	2
450	1000	29432M**		230		274		4,0	35,5	2,9
560	1000	29432EJ**		235	175,0	270	179	4,0	33,3	4,4
280	1100	29334M**	170	220		248		2,5	16,0	1,1
390	1200	29334EJ**		220	178,0	245	187,5	2,5	15,1	2,1
500	940	29434M**		245		291		4,0	43,7	3,6
570	950	29434EJ**		250	185,0	286	199	4,0	40,1	4,9
330	1000	29336M**	180	235		266		2,5	20,3	1,6
450	1100	29336EJ**		235	189,0	262	195	2,5	19,1	2,9
540	890	29436M**		260		307		4,0	52,0	4,5
650	900	29436EJ**		265	195,0	304	210	4,0	48,1	6,4
370	940	29338M*	190	250		283		3,0	24,8	2
450	1100	29338EJ**		250	199,0	280	208,5	3,0	23,3	2,9
590	840	29438M**		275		325		4,0	60,0	5,5
690	850	29438EJ**		280	206,0	321	223	4,0	55,7	7,5
300	1150	29240EM**	200	235		260		2,0	8,76	1,2
430	890	29340M*		265		300		3,0	33,0	2,8
500	950	29340EJ**		265	211,0	300	221,5	3,0	28,9	3,8
660	790	29440M*		290		343		4,0	69,0	7,1
770	800	29440EJ**		298	217,5	334	234	4,0	66,3	9,7
310	1300	29244EM**	220	285		260		2,0	9,64	1,4
440	840	29344M*		285		320		3,0	32,8	3,1
560	950	29344EJ**		285	229,0	316	237,5	3,0	31,6	5
690	750	29444M**		310		364		5,0	74,0	7,9
780	750	29444EJ**		315	238,0	355	254	5,0	69,1	10



Spherical roller thrust bearings

d = 240 to 380 mm

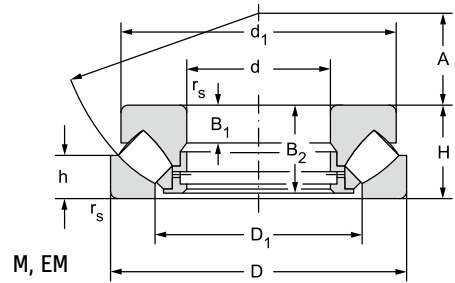
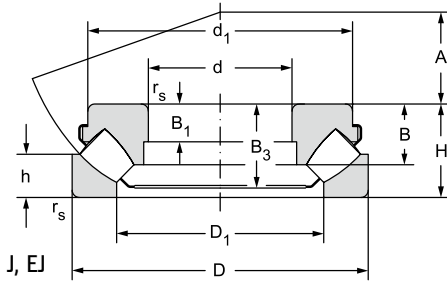

12-91

Main dimensions												Basic load rating	
d	D	H	d ₁	D ₁	B	B ₁	B ₂	B ₃	h	A	r _s	dynamic	static
mm												C _a	C _{0a}
												kN	
240	340	60	330,0	283,0		19	57,0		30,0	130	2,1	793	3450
	380	85	365,0	300,0		29	81,0		41,0	135	4,0	1340	5190
	380	85	343,7	294,8	54	29		75,0	40,5	135	4,0	1844	6490
	440	122	420,0	321,0		43	117,0		59,0	142	6,0	2410	8420
260	440	122	393,0	320,0	76	44		103,0	59,0	142	6,0	3039	9770
	360	60	350,0	302,0		19	57,0		30,0	139	2,1	825	3650
	420	95	405,0	325,0		32	91,0		45,0	148	5,0	1780	6820
	420	95	380,3	320,4	61	32		84,0	46,0	148	5,0	2307	8310
280	480	132	460,0	346,0		48	127,0		64,0	154	6,0	2812	9870
	480	132	430,7	344	86	48		117	63	154	6	3667	12080
	380	60	370,0	323,0		19	57,0		30,0	150	2,1	872	3950
	440	95	423,0	345,0		32	91,0		46,0	158	5,0	1780	7100
300	440	95	401,7	342,1	62	32		84,0	45,0	158	5,0	2276	8490
	520	145	495,0	380,0		52	140,0		68,0	166	6,0	3327	11840
	520	145	468,9	370,8	95	52		125,0	70,0	166	6,0	4604	15750
	420	73	405,0	355,0		21	69,0		38,0	162	3,0	1061	4670
320	480	109	460,0	375,0		37	105,0		50,0	168	5,0	2180	8500
	480	109	431,9	366,7	70	36		95,0	51,0	168	5,0	2730	11000
	540	145	515,0	398,0		52	140,0		70,0	175	6,0	3317	11850
	540	145	489,2	370,0	95	55		128,0	70,0	175	6,0	4645	16460
340	440	73	430,0	375,0		21	69,0		38,0	172	3,0	1102	4930
	500	109	482,0	395,0		37	105,0		53,0	180	5,0	2180	8850
	500	109	456,1	387,0	78	37		95,0	53,0	180	5,0	2936	10920
	580	155	555,0	430,0		55	149,0		75,0	191	7,5	4007	14690
360	580	155	525,6	421,8	102	55		134,0	74,5	191	7,5	5160	21200
	460	73	436,0	389,5		21	69,0		37,0	183	3,0	1442	6600
	540	122	520,0	424,0		41	117,0		59,0	192	5,0	2719	10550
	620	170	590,0	452,0		61	164,0		82,0	201	7,5	4481	16410
380	620	170	561,8	442,2	112	54		146,0	84,0	201	7,5	5995	25080
	500	85	485,0	420,0		25	81,0		44,0	194	4,0	1442	6600
	560	122	540,0	444,0		41	117,0		59,0	202	5,0	2730	11030
	520	85	505,0	440,0		27	81,0		42,0	202	4,0	1597	7510
380	670	175	622,0	504,0		63	168,0		85,0	222	7,5	4841	19100

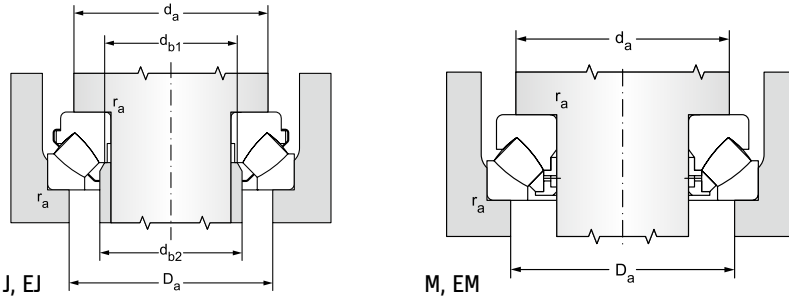

Deliveries of bearings marked * must be first consulted with the manufacturer, ** NEW FORCE

Fatigue load limit	Limiting speed for lubrication with	Bearing designation	Abutment and fillet dimensions						Weight	Minimum axial load factor
			d	d _a	d _{b1}	D _a	d _{b2}	r _a		
P _v	oil			min	max	max	max	max	-	
kN	min ⁻¹		mm						kg	
310	890	29248M**	240	285		311		2,0	16,7	1,5
450	790	29348M*		300		340		3,0	35,3	3,4
560	900	29348EJ**		305	249,0	336	256	3,0	33,4	5,3
710	750	29448M**		330		383		5,0	79,0	8,9
830	750	29448EJ**		335	258,0	377	276	5,0	73,5	12
320	890	29252M**	260	305		331		2,0	18,5	1,7
580	750	29352M*		330		374		3,0	48,5	5,8
700	800	29352EJ**		335	272,0	370	283,2	4,0	46,9	8,6
810	670	29452M**		360		419		5,0	105	12
990	670	29452EJ**		406	278	378	296	5	96,1	18
340	840	29256M**	280	325		351		2,0	19,5	2
590	710	29356M*		350		394		4,0	52,5	6,3
710	800	29356EJ**		355	293,0	390	302	4,0	49,5	9
950	630	29456M*		390		453		5,0	132	18
1 300	630	29456EJ**		395	298,0	446	316,5	5,0	127	31
390	750	29260M**	300	355		386		2,5	30,5	2,7
690	630	29360M*		380		429		4,0	74,0	9
890	700	29360EJ**		385	312,0	423	325,8	4,0	68,7	15
940	600	29460M*		410		471		5,0	140	18
1 300	600	29460EJ**		415	318,0	465	339	5,0	133	34
400	710	29264M**	320	375		406		2,5	32,9	3
710	630	29364M*		400		449		4,0	77,0	9,8
870	670	29364EJ**		405	332,0	442	336	4,0	72,1	15
1 100	560	29464M*		435		507		6,0	175	27
1 600	560	29464EJ**		450	342,0	500	364	6,0	164	56
530	850	29268EM**	340	400		422		2,5	33,0	5,4
820	560	29368M**		430		484		4,0	103	14
1 300	500	29468M**		465		451		6,0	218	34
1 900	380	29468EJ**		475	358,0	530	364	6,0	211	79
520	630	29272M**	360	420		461		3,0	51,8	5,4
850	560	29372M**		450		504		4,0	107	15
580	600	29276M**	380	440		480		3,0	52,8	7,1
1 400	470	29476EM**		504		570		6,0	263	46



Spherical roller thrust bearings

d = 400 to 750 mm

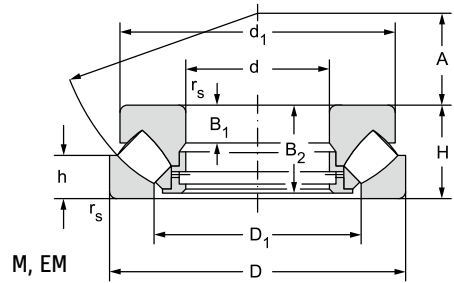
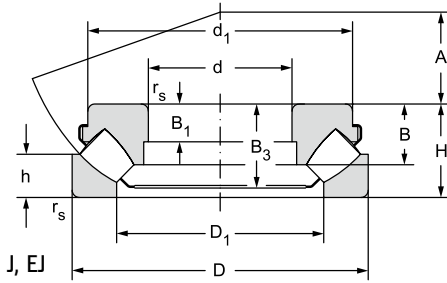

Main dimensions												Basic load rating	
d	D	H	d ₁	D ₁	B	B ₁	B ₂	B ₃	h	A	r _s	dynamic	static
mm												C _a	C _{0a}
												kN	
400	540	85	526,0	460,0		27	81,0		42,0	212	4,0	1648	7900
	620	132	596,0	494,0		44	127,0		64,0	225	6,0	3389	14120
	710	185	680,0	530,0		67	178,0		89,0	236	7,5	7014	26500
420	580	95	553,0	484,2		30	91,0		46,0	225	5,0	2369	11230
	650	140	626,0	520,0		48	135,0		68,0	235	6,0	3512	14700
	730	185	663,0	540,0		67	175,0		90,0	244	7,5	7056	31020
440	680	145	655,0	546,0		49	140,0		70,0	245	6,0	3976	16850
	780	206	745,0	576,0		74	199,0		100,0	260	9,5	6468	24650
	780	206	718	554		77	199		101	257	9,5	8250	33270
480	650	103	635,0	554,0	61	33	99,0		55,0	259	6,0	1978	11000
	850	224	772,0	611,6		81	214,0		108,0	280	9,5	9935	44398
500	670	103	654,0	574,0		33	99,0		55,0	268	5,0	2472	12120
	750	150	725,0	611,0		51	144,0		74,0	280	6,0	4347	18660
	870	224	801,0	625,6		81	218,0		110,0	290	9,5	10326	48568
530	800	160	772,0	648,0		54	154,0		76,0	295	7,5	5284	22730
600	800	122	760,0	680,0		44	117,0		60,0	321	5,0	3832	19060
	900	180	850,0	731,0		64	171,0		87,0	335	7,5	7004	31500
630	850	132	820,0	724,0		42	127,0		67,0	338	6,0	4378	22500
	950	190	880	743		68	183		92	359	9,5	8940	38700
	1090	280	995	796		107	270		137	365	12	15244	63200
670	900	140	858,0	762,0		50	130,0		73,0	361	6,0	4635	23280
	1150	290	1045	844		110	280		141	387	15	16274	69300
710	1060	212	985	835		74	205		103	405	9,5	10506	46400
	1220	308	1110,0	899,0		118	298,0		149,0	415	15,0	18128	76500
750	1000	150	950	838		52	144		74	409	6	6448	31600
	1120	224	1086	890		76	216		109	415	9,5	9909	45800
	1280	315	1170	942		122	305		153	436	15	19776	86600

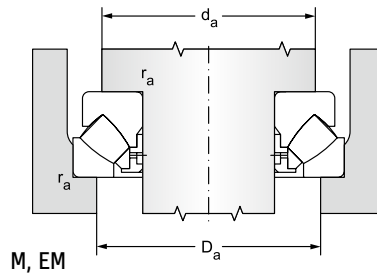
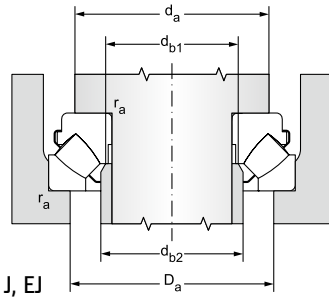

Deliveries of bearings marked * must be first consulted with the manufacturer, ** NEW FORCE

Fatigue load limit	Limiting speed for lubrication with	Bearing designation	Abutment and fillet dimensions						Weight	Minimum axial load factor
			d	d _a	d _{b1}	D _a	d _{b2}	r _a		
P _v	oil			min	max	max	max	-		
kN	min ⁻¹		mm						kg	
610	600	29280M**	400		460,0	500	3		55,3	7,8
1 100	500	29380M**			498,0	557	5		150	25
1 900	450	29480EM**			550,0	615	6		306	88
850	700	29284EM**	420	500		525		4	73,0	16
1 100	450	29384M**			523,0	585	5		170	27
2 200	430	29484EM**			592,0	684	8		308	120
1 200	450	29388M**	440		548,0	614	5		190	35
1 700	400	29488M**			592,0	684	8		407	76
2 400	380	T29488EM**		612		662		8	412	140
800	500	29296M**	480		558,0	603	4		96,5	15
3 100	340	29496EM**			660,0	735	8		518	250
870	470	292/500M**	500		578,0	622	4		101	18
1 300	400	293/500M**			613,0	680	5		220	44
3 300	340	294/500EM**		685		755		8	548	290
1 600	380	293/530M**	530		651,0	724	6		286	65
1 300	450	292/600EM**	600	700		725		4	160	45
2 100	330	293/600EM**			735,0	815	6		390	120
1 500	350	292/630M**	630		730,0	789	5		211	63
2500	320	293/630EM**		795		860		8	488	190
4000	260	294/630EM**		860		950		10	1108	500
1 500	380	292/670EM**	670	790		815		5	237	68
4300	240	294/670EM**		905		1000		12	1269	600
2900	280	293/710EM**	710	890		960		8	665	270
4 700	220	T 294/710EM**		970		1050		12	1420	730
2000	325	292/750EM**	750	880		925		5	327	120
2800	260	293/750EM**		935		1000		8	775	260
5200	200	274/750EF**		1015		1120		12	1660	940



Spherical roller thrust bearings

d = 800 to 1120 mm

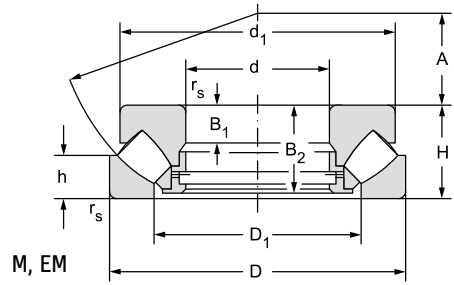
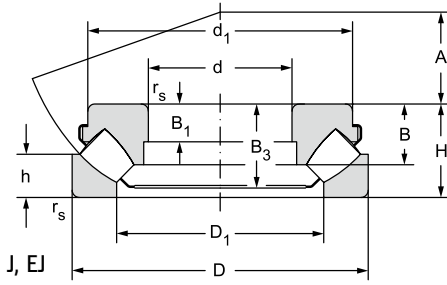

Main dimensions												Basic load rating	
d	D	H	d ₁	D ₁	B	B ₁	B ₂	B ₃	h	A	r _s	dynamic	static
											min	C _a	C _{0a}
mm											kN		
800	1060	155	1010	890		52	149		77	434	7,5	6942	35200
	1180	230	1146	943		78	222		111	440	9,5	10506	49900
	1360	335	1300,0	1040,0		120	324,0		162,0	462	15,0	16830	72360
	1360	335	1250	1010		122	324		165	462	15	21321	94800
850	1120	160	1060	945		47	154		82	455	7,5	7117	36700
950	1250	180	1185	1056		58	174		88	507	7,5	8755	46400
1000	1460	276	1365	1165		100	267		137	561	12	18334	88100
1060	1400	206	1325	1183		66	199		100	566	9,5	11124	59600
1120	1460	206	1385	1243		70	199		97	601	9,5	11948	63100

12-9.1

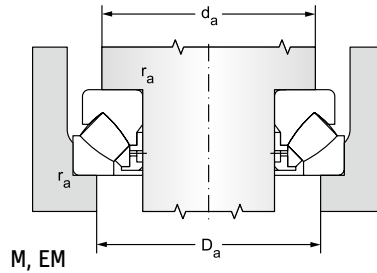
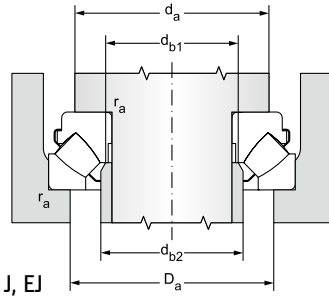

Deliveries of bearings marked * must be first consulted with the manufacturer, ** NEW FORCE

Fatigue load limit	Limiting speed for lubrication with	Bearing designation	Abutment and fillet dimensions					Weight	Minimum axial load factor
			d	d _a	d _{b1}	D _a	d _{b2}		
P _v	oil		min	max	max	max	max	-	
kN	min ⁻¹		mm					kg	
2200	320	292/800EM**	800	935		980	6	383	150
3000	240	293/800EM**		995		1060	8	871	310
4 300	220	294/800M **			1055,0	1200	12	2010	650
5600	190	294/800EF**	1080			1185	12	2039	1100
2200	300	292/850EM**	850	980		1030	6	428	170
2700	260	292/950EM**	950	1095		1155	6	604	270
5000	180	293/1000EF**	1000	1245		1330	10	1560	970
3400	220	292/1060EF**	1060	1225		1290	8	866	440
3500	220	292/1120EF**	1120	1300		1365	8	906	500







12.10 SPLIT ROLLER BEARINGS

Our company currently devotes special attention to particular bearings, designed primarily for heavy industrial applications. Here we refer to split roller bearings, whose design and production technology are validated at ZKL on special cylindrical roller bearings and spherical roller bearings up to an outer diameter of 1600 mm. We are constantly expanding our product line, and ZKL ranks among the world's leading manufacturers.

Split roller bearings are preferred in settings, where axial installation of bearings in housings is unfeasible, which applies, for example, to multiple bearing shafts, crankshafts, long transmission shafting, or in cases, where installation of the bearing in the housing would be too time-consuming and where any prolonged shutdown of equipment could lead to large disruptions in operations.

The most commonly used split roller bearings in the world are single row cylindrical roller (fig. 12.10.1) and double row spherical roller bearings (fig. 12.10.2). ZKL includes both of the specified assemblies in its production program. These bearings have a radially split outer ring, inner ring, and cage for guiding rolling elements. Cages are usually made of massive brass. Both halves of the cage are connected to withstand dynamic forces, which the cage is exposed to during operation. Both halves of the inner ring are secured on the shaft by means of clamping rings with a screw lock element to prevent their release. The separating gap between the halves of the outer ring may be perpendicular to the face of the ring. The dividing plane of the inner ring, in contrast, should be inclined at an angle to prevent shock in the loaded zone at the edge of the dividing plane when the elements are rolling.

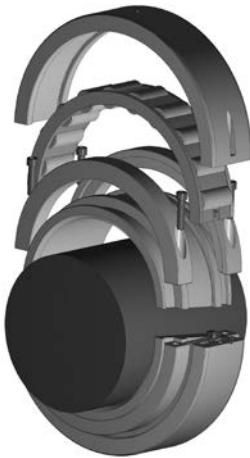

Fig. 12.10.1

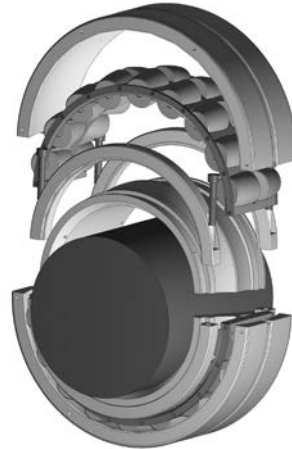

Fig. 12.10.2



Size range of split roller and spherical roller bearings

The size of special split roller bearings ranges, in the internal ring bore from $d = 150$ mm to 1 200 mm and in the outer ring diameter up to 1 600 mm.

ZKL split roller bearings can be designed to manage either radial and axial loads, or only radial loads.



ZKL split spherical roller bearings are able to carry primarily radial, but also partial axial external loads in both directions.

Split spherical roller and roller bearings are designed with clamping rings that fit in the circular grooves of the inner rings. The screw assemblies of the split raceways are connected with special screws and the manufacturer specifies the tightening torque for individual sizes.

Installing bearings

When installing bearings with split rings, we recommend that the shaft diameter have an h6, or in extreme cases, an h7 to h9 tolerance rating. Shape variations of loading surfaces can be utilized at a maximum of up to 50% of the fitting tolerance. IT6 precision of loading surfaces is most often required. Prior to installing the bearings into the housing, we recommend that fitting paste be sparingly applied to loading surfaces to limit the formation of contact-borne corrosion. Installation of bearings into the loading should be performed by trained and experienced work personnel.

Lubrication of split bearings

Split bearing lubrication is subject to normal roller bearing requirements. Either an oil or grease lubricant may be used. The type of lubricant is selected, based on the operating conditions, the given maximum speed, the operating temperature, and the magnitude of the external load. The Technical and Consultation Services Department can assist in selecting a suitable lubricant.

Housings for split bearings

Comprehensive bearing loading solutions can be designed for individual split bearings and loadings, which consists of a split bearing, the bearing housing, the lubrication system, and bearing diagnostics per customer specifications. Comprehensive solutions may be applied to both new loadings, which are in the prototype design phase, as well as for existing loadings that require substitution of a regular non-split bearing for a split bearing. Complete specifications are needed in both cases to achieve the optimal loading design. A complete specifications form, on the basis of which we produce an optimal structural design of the given loading, is available from the supplier upon request or, as necessary, following consultation by the ZKL Technical and Consultation Services Department.

Recommendations

Manufacturing of split bearings is a demanding process, and ZKL achieves this by mastering specialized steel heat-treatment procedures and individual component separation techniques, which eliminate any undesired stress and subsequent deformation of the material. The special approach in designing personal loadings and creating installation procedures demands close cooperation with the customer. For example, the standard equations usually cannot be used when calculating the bearing durability without first determining the correcting factors. We therefore recommend that the loading design and installation procedures always be consulted with ZKL Technical and Consultation Department personnel.

Split roller bearings may also be offered in different types and designs (e.g. radial ball, thrust ball, etc.).

When substituting an original non-split bearing with a split bearing, we recommend that the customer also contacts ZKL Technical Office personnel.



Split spherical roller bearings d = 25 to 1120 mm

d = 280 to 850 mm

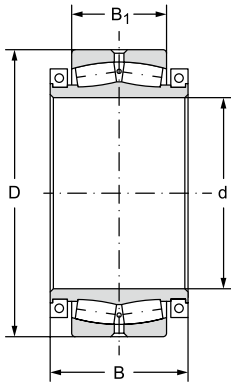

12.10.1

Main dimensions				Basic load rating	
d	D	B	B ₁	Dynamic C _r	Static C _{or}
mm				kN	
280	500	260	176	2760	4890
300	500	240	160	2790	5100
360	540	220	134	2340	4650
400	600	240	148	3020	5970
420	620	238	150	2940	6140
460	700	245	165	3380	6810
470	720	270	167	3710	7730
560	800	230	150	3500	8310
	870	330	200	5160	1160
600	920	310	212	5810	12500
	980	515	375	10800	22200
630	920	310	212	5920	12200
670	980	350	230	6570	14700
	1150	500	345	13000	23500
710	950	375	243	5920	15900
	1030	360	236	7300	16100
750	1000	360	250	6380	17200
	1090	475	335	10100	25200
800	1060	370	258	7100	19300
	1150	490	325	13000	31900
850	1120	390	272	7730	21200
	1180	331	206	6570	17900
	1280	430	280	10400	24100
	1280	540	375	12900	31900

Fatigue load limit	Weight	Bearing designation
P_u	~	
kN	kg	
396	175	PLC512-40
410	150	PLC512-41
361	155	PLC512-42
449	205	PLC512-43
457	215	PLC512-44
490	340	PLC512-45
552	375	PLC512-46
570	320	PLC512-47
78	580	PLC512-48
830	690	PLC512-49
1460	1350	PLC512-50
805	630	PLC512-51
952	800	PLC512-52
1480	1710	PLC512-39
1030	700	PLC512-53
1030	880	PLC512-54
1090	1220	PLC512-37
1580	1300	PLC512-56
1210	810	PLC512-57
1960	1980	PLC512-58
1300	830	PLC512-59
1090	880	PLC512-60
1450	1550	PLC512-61
1910	2350	PLC512-62



Split spherical roller bearings

d = 900 to 1120 mm

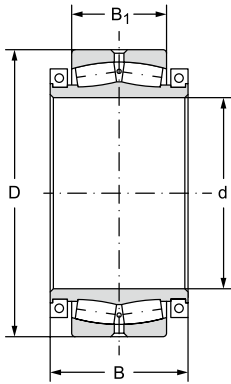

12.10.1

Main dimensions				Basic load rating	
d	D	B	B ₁	Dynamic C _r	Static C _{0r}
mm				kN	
900	1180	400	280	8580	23300
	1340	490	325	12600	31500
950	1250	300	220	6400	20000
	1250	420	300	9240	26500
1000	1470	530	345	15200	37600
1020	1280	352	218	6280	20000
1060	1460	500	335	11700	35100
1060,355	1400	490	335	11600	33300
1120	1460	500	335	12000	34600
	1540	525	335	14000	39800

Fatigue load limit	Weight	Bearing designation
P_u	~	
kN	kg	
1410	1100	PLC512-63
1860	1800	PLC512-64
1190	987	PLC512-55
1570	1300	PLC512-65
2160	3000	PLC512-66
1170	950	PLC512-67
2000	2470	PLC512-68
1910	1800	PLC512-69
1960	2070	PLC512-70
2230	2950	PLC512-71



Split cylindrical roller bearings d = 150 to 600 mm

d = 150 to 238 mm

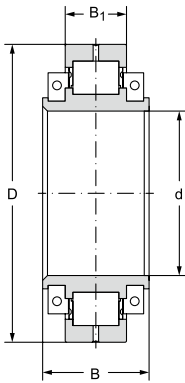

12.10.2

Main dimensions				Basic load rating	
d	D	B	B ₁	Dynamic C _r	Static C _{0r}
mm				kN	
150	254	98,4	55,6	454	653
	292,1	123,8	68,3	810	1090
	330,2	160	81	1180	1520
155	254	98,4	55,6	454	652
	292,1	123,8	68,3	810	1090
160	273,05	109	60,3	513	750
	317,5	140	83,3	854	1120
	355,6	171	103,2	1370	1960
165	317,5	140	83,3	854	1120
170	285,75	109	55,5	551	840
	355,6	171	103,2	1370	1960
180	285,75	109	55,5	551	841
	330,2	140	83,3	942	1290
	374,65	178	92,1	1480	2130
190	311,15	109	60,3	576	936
	368,3	156	90,5	1100	1570
	419,1	191	97,7	1580	2530
195	368,3	156	90,5	1100	1570
200	311,15	109	60,3	576	936
	419,1	191	97,7	1580	2530
203,2	368,36	156	90,5	1040	1520
218	393,76	156	90,5	1200	1760
220	393,76	156	90,5	1200	1760
	342,9	115	63,5	623	1040
	469,9	212	109,6	1900	2700
238	440,07	156	90,5	1250	1920

Fatigue load limit	Weight	Bearing designation
P_u	~	
kN	kg	
65	16,6	PLC410-49
105	64,0	PLC411-36
143	57,0	PLC411-43
64	16,6	PLC410-50
104	64,0	PLC411-37
73	20,0	PLC411-29
105	39,0	PLC411-38
180	72,0	PLC411-44
105	39,0	PLC411-39
80	23,0	PLC411-30
179	72,0	PLC411-45
80	23,0	PLC411-31
119	45,0	PLC411-40
191	79,0	PLC411-46
87	25,0	PLC411-32
141	59,0	PLC411-41
221	105	PLC412-43
140	59,0	PLC411-42
86	25,0	PLC411-33
220	105	PLC412-44
135	62,0	PLC411-28
153	83,8	PLC411-27-1
153	83,0	PLC411-27
93	32,0	PLC411-34
227	145	PLC412-45
162	92,0	PLC412-7-1



Split cylindrical roller bearings

d = 240 to 420 mm

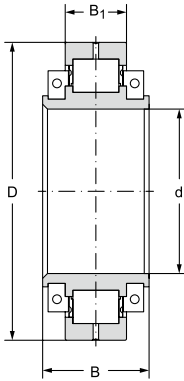

12.10.2

Main dimensions				Basic load rating	
d	D	B	B ₁	Dynamic C _r	Static C _{0r}
mm				kN	
240	374,65	122	66,7	691	1240
	440,07	156	90,5	1250	1920
	482,6	211	105,6	2120	3190
260	431,8	170	96,8	1140	1940
	406,4	128	69	783	1410
	482,6	211	105,6	2120	3190
280	406,4	128	69	783	1410
	463,55	186	101,6	1520	2320
	495,3	244	139,7	2450	4040
300	438,15	143	74,6	8230	1540
	495,3	193	103,2	1620	2600
	558,8	244	139,7	2520	4140
320	622,37	272	160,4	3100	4950
	463,55	136	74,6	915	1740
	527,05	192	106,4	1730	2830
340	488,95	136	74,6	940	1890
	565,15	200	115,9	1920	3180
	615,95	279	158	3190	5490
360	520,7	140	76,2	1010	2050
	565,15	200	115,9	1920	3180
	615,95	279	158	3190	5490
380	520,7	140	76,2	1010	2050
	584,2	200	111,1	2020	3510
	685,8	292	166,7	3530	6000
400	546,1	140	76,2	1050	2200
	615,95	200	115,9	2120	3710
	685,8	292	166,7	3530	6000
420	571,5	140	76,2	1070	2360
	647,7	200	119,1	2230	4000
	700	284	160	4020	7510

Fatigue load limit	Weight	Bearing designation
P_u	~	
kN	kg	
108	40,0	PLC411-35
162	92,0	PLC412-7
265	150	PLC412-46
163	86,5	PLC412-11
120	50,0	PLC412-61
262	150	PLC412-47
119	50,0	PLC412-13
191	86,0	PLC412-28
328	182	PLC412-48
127	60,0	PLC412-14
210	123	PLC412-29
326	238	PLC412-49
379	353	PLC412-8
141	72,0	PLC412-15
224	150	PLC412-30
150	78,0	PLC412-16
247	182	PLC412-31
419	318	PLC412-50
160	86,0	PLC412-17
245	182	PLC412-32
416	318	PLC412-51
159	86,0	PLC412-18
267	186	PLC412-33
443	431	PLC412-52
168	95,0	PLC412-19
278	209	PLC412-34
440	431	PLC412-53
178	104	PLC412-20
295	241	PLC412-35
546	395	PLC412-54



Split cylindrical roller bearings

d = 440 to 600 mm

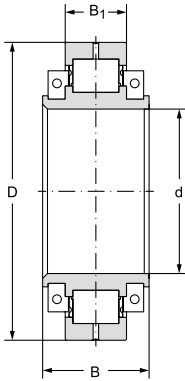

12.10.2

Main dimensions				Basic load rating	
d	D	B	B ₁	Dynamic C _r	Static C _{0r}
mm				kN	
440	596,9	140	76,2	1110	2510
	666,75	200	115,9	2370	4380
	700	284	160	4020	7510
460	596,9	140	76,2	1110	2510
	666,75	200	115,9	2370	4380
	740	294	170	4270	7700
480	628,65	144	81	1150	2580
	698,5	223	119,1	2500	4770
500	654,05	168	80,2	1190	2750
	717,55	226	115,9	2600	5160
	850,9	300	187,4	4790	8800
530	692,15	168	81	1230	2920
	762	229	119,1	2850	5550
	850,9	300	187,4	4790	8800
560	717,55	168	81	1270	3090
	793,75	233	122,2	2970	6000
	863,6	310	196,9	5380	10600
600	774,7	172	84,1	1400	3510
	838,2	214	119,1	3070	6470
	890	310	184	5610	11400

Fatigue load limit	Weight	Bearing designation
P_u	~	
kN	kg	
187	114	PLC412-21
320	250	PLC412-36
543	395	PLC412-55
186	114	PLC412-22
318	250	PLC412-37
549	431	PLC412-56
188	128	PLC412-23
342	263	PLC412-38
198	136	PLC412-24
366	272	PLC412-39
605	730	PLC412-57
207	164	PLC412-25
387	309	PLC412-40
601	730	PLC412-58
216	175	PLC412-26
412	336	PLC412-41
717	635	PLC412-59
240	210	PLC412-27
437	381	PLC412-42
761	680	PLC412-60







12.11 BEARINGS FOR RAILWAY APPLICATIONS

The rail industry is a promising field world-wide. ZKL therefore dedicates special attention to bearings for rail vehicles. The product range of these bearings includes bearings for various types of drives, pumps, and fans, as well as for rail vehicle axles. Traction motors of electrical locomotives and driving electrical units are a special category. ZKL is expanding its product line by the addition of compact tapered units as well as conventional and electrically insulated bearings for traction motors. Aside from special bearings, ZKL offers additional technical support in this industry through servicing. We recommend that the customer consults delivery conditions of manufactured bearings with ZKL qualified personnel.

Axle bearings

The development and production of ZKL railway bearings meet CSN EN 12080 and UIC 510-1 standard requirements. Bearings are designed using modern engineering and computer programs. Parameters are verified through rigorous testing of bearings at testing stations according to ZKL methodology, UIC 515-5 and CSN EN 12082 standards.

Cylindrical roller bearings

They are particularly suitable for transferring high radial loads as well as shock axial loads at high revolution speeds. They are manufactured in pairs that comprise two single row bearings. The internal bearings are designed with a single flange on the inner ring (NJ). The external bearing is designed with an inner ring and without a fixed flange. This bearing includes an independent guiding collar, which attaches from the external side of the bearing pair.

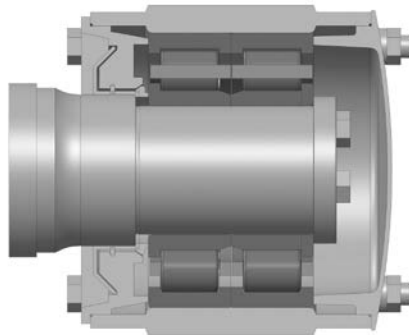

Fig. 12.11.1

The bearings correspond in design to bearings with international markings:

NJ/NJP (WJ/WJP) 120x240

ZKL: PLC 410-13/14 or PLC 410-13/14.2, resp.

NJ/NJP (WJ/WJP) 130x240

ZKL: PLC 410-33/34.2



PLC 410-15/16 (PLC 410-15/16.2) bearings differ from PLC 410-33/34 bearings in the diameter of the inner ring raceway (parameter F in the catalogue table). These bearings are not interchangeable except in those applications approved in the customer documentation.

Cylindrical roller bearings have an optimized internal design for capturing dynamic forces both in a radial and axial direction and for ensuring perfect lubrication under all operating conditions.

Bearings are manufactured with a massive brass cage or plastic cage. Bearings with a plastic cage are marked with index 2 to differentiate the markings. Massive plastic cages (fig. 12.11.2) meet the most demanding operating requirements for railway vehicles. They are made from fibreglass reinforced polyamide PA66-GF25.

The bearing arrangement according to fig. 12.11.1 is an advantage, because it allows separate installation of inner rings on the journal and outer rings with rollers in the bearing housing. Recommended loading tolerances are provided in table 12.11.1.

Table 12.11.1

Component		Diameter tolerances	Shape and position deviations
journal	$\varnothing d_1$	t7	7
journal	$\varnothing d$	p6	5
housing	$\varnothing D$	H7	6

The grease type for the particular application is determined by the operator upon receiving consent from the bearing manufacturer.

Bearings are also manufactured with a reduced inner ring bore diameter for use on axles with re-machined journals. Bearings are marked with an index rating. The parameters of all bearings, including clearances and speeds, for which the bearings are structurally designed, are specified in the catalogue tables.

Tabered bearing units

These are special double row tapered roller bearings for supporting axles of high-speed personal and commercial rail vehicles (fig. 12.11.3).



Fig. 12.11.2



Fig. 12.11.3

Bearings consist of a common outer ring, two internal rings, and two rows of tapered rolls with cages made from fibreglass reinforced polyamide PA66-GF25. Bearing rings are surface treated with zinc phosphate. The optimum axial clearance of the bearings is set and the bearings are supplied prepared for direct installation. The internal space is sealed using special seals or covers that ensure reliable operation of bearings. The service intervals for bearings are determined according to the rail vehicle operating conditions and servicing of bearings is performed by the manufacturer. Installation and removal of these units for railway vehicle axles is easy, quick, and safe with the use of hydraulic equipment. Installation instructions are issued for installing bearings in individual loadings.

The bearings correspond in design to bearings with international markings:

TBU (CTBU) 130x230	ZKL: PLC 810-13
TBU 130x210	ZKL: PLC 810-15

Bearing alternatives for various loadings differ from the basic marking in their index rating, which comprises a number or combination of number and letter.

Spherical roller bearings

They are suitable for handling large radial forces. Their design also enables simultaneous transfer of substantial axial loads in both directions. The bearings are inclined; they are thus able to compensate for some misalignment or shaft deflection. These characteristics make them very suitable for all heavy load applications. In addition to axle loadings, particularly of older types of railway vehicles, these bearings are used, for example, in gearboxes and fan drives.

Bearings are manufactured with a massive brass cage (M, EMH) and increased radial clearance in line with special technical conditions.

Calculations

The equations specified in chapter 5.5 Basic durability equations apply for bearing durability calculations. To properly determine the equivalent load P of dynamically loaded axle bearings, we recommend the use of auxiliary load factors, where are 1.2 to 1.3 for personal wagons, 1.2 to 1.4 for freight wagons, and 1.3 to 1.8 for driving vehicles.

Bearings for traction motors

Bearings for traction motors are designed to meet demands for efficiency, high durability, and reliability. Traction motor bearings work under heavy-duty operating conditions with high loads and rotation speeds. They may consequently be manufactured with a higher degree of precision (P6, P5) and with increased radial clearance (C3, C4). The thermal treatment of bearing rings guarantees stability of component dimensions during operation at higher temperatures. The internal design of bearings ensures their high axial load-bearing capacity during operation. Bearings are manufactured with a solid brass cage that is guided along rolling elements (M) or along an external ring (MA). The cage and guiding surfaces are designed to provide optimal lubrication and low generation of heat.



Traction motor bearings are usually single row ball bearings, for supporting reduced radial loads and high speed operation, or single row roller bearings for supporting high radial loads. Roller bearings are also used for loadings that enable axial displacement of components due to thermal dilatation of dimensions.

Traction motor bearings are supplied in a non-insulated version with an insulated ceramic Al_2O_3 coating that prevents the passage of electrical current through the bearing and prevents the formation of damage to raceways and the lubricant. The resistance of the coating is guaranteed up to 1 000 V DC. The suffix for bearings with this insulation coating on the outer ring is TM01. Information about the ceramic coating is provided in the chapter on electrically insulated bearings in the chapter Special bearings. For more detailed information, refer to the ZKL Technical and Consultation Services Department.



Fig. 12.11.4

Recommended loading tolerances are provided in table 12.11.2.

Table 12.11.2

	Shaft diameter			Bore diameter	
	Ball	Roller	Tolerances		Tolerances
Fans	80–100	up to 40	j6		J7
Generators	100–200	40–140	k6		K7
Electric motors	18–100	up to 40	k5		M7
	100–200	40–140	m5		
	140–200	100–140	m6		
Traction motors		50–140	n6*		H7
		140–500	p6		



Single row ball bearings for traction motors $d = 65$ to 150 mm

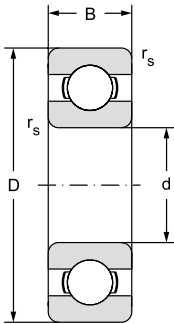

12.11.1

Main dimensions				Basic load rating		Fatigue load limit
d	D	B	r_s	Dynamic C_r	Static C_{or}	P_u
mm				kN		kN
65	100	18,0	1,1	30,50	25,10	1,141
	120	23,0	1,5	57,20	40,01	1,891
70	110	20,0	1,1	37,96	30,96	1,407
	125	24,0	1,5	62,00	43,80	2,016
75	115	20,0	1,1	39,75	33,17	1,547
	130	25,0	1,5	66,18	49,31	2,214
80	125	22,0	1,1	47,50	39,80	1,787
	140	26,0	2,0	72,20	53,10	2,301
	170	37,0	2,1	122,85	86,23	3,506
85	150	28,0	2,0	83,30	63,68	2,670
	180	41,0	3,0	132,51	96,07	3,794
90	160	30,0	2,0	96,20	70,80	2,878
	190	43,0	3,0	144,00	108,00	4,149
95	170	32,0	2,1	108,00	81,00	3,199
	200	45,0	3,0	152,44	117,37	4,393
100	180	34,0	2,1	123,00	92,60	3,557
	215	47,0	3,0	174,00	141,00	5,107
110	200	38,0	2,1	144,00	117,00	4,272
	240	50,0	3,0	203,00	180,00	6,185
120	215	40,0	2,1	144,00	117,00	4,109
	260	55,0	3,0	208,00	186,00	6,134
130	230	40,0	3,0	156,00	132,00	4,472
	280	58,0	4,0	229,00	216,00	6,857
140	250	42,0	3,0	166,00	150,00	4,883
	300	62,0	4,0	251,00	245,00	7,508
150	270	45,0	3,0	190,00	181,00	5,677
	320	65,0	4,0	276,00	285,00	8,451

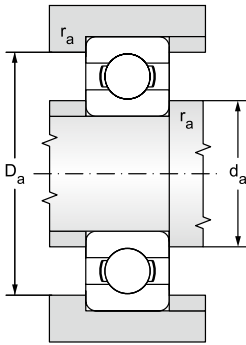

Limiting speed for lubrication with		Bearing designation		Abutment and fillet dimensions			Weight
grease	oil		electrically insulated	d_a min	D_a max	r_a max	~
min ⁻¹				mm			kg
6300	7500	6013M	6013M TM01	70,0	93,0	1,0	0,44
5300	6300	6213M	6213M TM01	72,0	111,0	1,5	1,00
5600	6700	6014M	6014M TM01	75,0	103,0	1,0	0,61
5300	6300	6214M	6214M TM01	77,0	116,0	1,5	1,07
5300	6300	6015M	6015M TM01	80,0	108,0	1,0	0,65
5000	6000	6215M	6215M TM01	82,0	122,0	1,5	1,18
5000	6000	6016M	6016M TM01	85,0	118,0	1,0	0,87
4700	5600	6216M	6216M TM01	90,0	130,0	2,0	1,40
4000	4700	6316M	6316M TM01	91,0	158,0	2,0	3,63
4200	5000	6217M	6217M TM01	95,0	140,0	2,0	1,80
3800	4500	6317M	6317M TM01	98,0	166,0	2,5	4,20
4000	4700	6218M	6218M TM01	100,0	150,0	2,0	2,16
3500	4200	6318M	6318M TM01	103,0	176,0	2,5	4,95
3800	4500	6219M	6219M TM01	107,0	158,0	2,0	2,60
3300	4000	6319M	6319M TM01	109,0	186,0	2,5	5,72
3500	4200	6220M	6220M TM01	112,0	169,0	2,0	3,13
3200	3800	6320M	6320M TM01	113,0	201,0	2,5	7,07
3200	3800	6222M	6222M TM01	122,0	188,0	2,0	4,37
2600	3200	6322M	6322M TM01	123,0	227,0	2,5	9,58
3000	3500	6224M	6224M TM01	132,0	203,0	2,0	5,15
2500	3000	6324M	6324M TM01	134,0	246,0	2,5	12,5
2600	3100	6226M	6226M TM01	144,0	216,0	2,5	5,75
2350	2800	6326M	6326M TM01	147,0	263,0	3,0	15,2
2500	3000	6228M	6228M TM01	154,0	236,0	2,5	7,56
2350	2800	6328M	6328M TM01	157,0	283,0	3,0	21,8
2200	2700	6230M	6230M TM01	164,0	256,0	2,5	9,85
2000	2400	6330M	6330M TM01	167,0	303,0	3,0	24,0



Single row cylindrical roller bearings for traction motors $d = 35$ to 150 mm



NJ

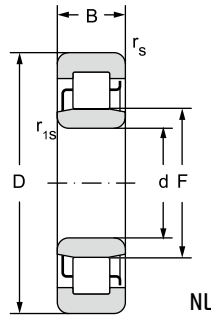

NU

$d = 35$ to 90 mm

12.11.2

Main dimensions							Basic load rating		Fatigue load limit	Limiting speed for lubrication with	
d	D	B	r _s min	r _{1s} min	F	s ₁	dynamická C _r	statická C _{or}	P _u	grease	oil
mm							kN		kN	min ⁻¹	
35	62	14,00	1,0	0,6	42,000	1,0	22,6	23,2	2,83	11000	13000
40	68	15,00	1,0	0,6	47,000	1,0	27,3	29,0	3,54	10000	12000
45	75	16,00	1,0	0,6	52,500	1,0	32,5	35,5	4,33	9000	11000
50	80	16,00	1,0	0,6	57,500	1,5	32,0	36,0	4,39	8000	10000
55	90	18,00	1,1	1,0	64,500	1,5	37,5	44,0	5,37	7500	9000
60	95	18,00	1,1	1,0	69,500	2,0	41,0	51,0	6,22	6700	8500
65	100	18,00	1,1	1,0	74,500	2,0	44,0	57,0	6,95	6300	8000
70	110	20,00	1,1	1,0	80,000	2,0	59,0	71,0	8,66	6000	7100
125	24,00	1,5	1,5	83,500	1,6	119,0	137,0	16,71	5000	6300	
125	24,00	1,5	1,5	83,500	1,6	119,0	137,0	16,71	5000	6300	
150	35,00	2,1	2,1	89,000	1,5	205,0	222,0	26,31	4000	5000	
150	35,00	2,1	2,1	89,000	1,5	205,0	222,0	26,31	4000	5000	
75	115	20,00	1,1	1,0	85,000	2,5	60,0	74,5	9,23	5600	6700
130	25,00	1,5	1,5	88,500	1,6	130,0	156,0	18,88	4800	6000	
130	25,00	1,5	1,5	88,500	1,6	130,0	156,0	18,88	4800	6000	
160	37,00	2,1	2,1	95,000	1,5	240,0	263,0	30,56	3800	4800	
160	37,00	2,1	2,1	95,000	1,5	240,0	263,0	30,56	3800	4800	
80	125	22,00	1,1	1,0	91,500	2,5	72,5	90,5	10,96	5300	6300
140	26,00	2,0	2,0	95,300	2,0	139,0	167,0	19,79	4500	5300	
140	26,00	2,0	2,0	95,300	2,0	139,0	167,0	19,79	4500	5300	
170	39,00	2,1	2,1	101,000	1,5	256,0	282,0	32,16	3600	4300	
170	39,00	2,1	2,1	101,000	1,5	256,0	282,0	32,16	3600	4300	
85	150	28,00	2,0	2,0	100,500	2,0	167,0	199,0	23,12	4300	5000
150	28,00	2,0	2,0	100,500	2,0	167,0	199,0	23,12	4300	5000	
180	41,00	3,0	3,0	108,000	2,0	291,0	330,0	36,99	3300	4000	
180	41,00	3,0	3,0	108,000	2,0	291,0	330,0	36,99	3300	4000	
90	160	30,00	2,0	2,0	107,000	2,0	182,0	217,0	24,75	4000	4800
160	30,00	2,0	2,0	107,000	2,0	182,0	217,0	24,75	4000	4800	
190	43,00	3,0	3,0	113,500	2,0	315,0	355,0	39,14	3200	3800	
190	43,00	3,0	3,0	113,500	2,0	315,0	355,0	39,14	3200	3800	

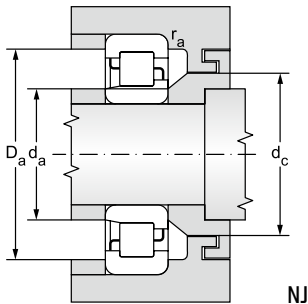

NJ

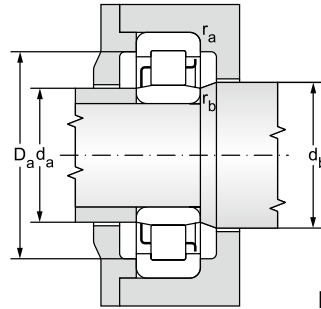

NU

¹⁾ Admissible axial movement

Bearing designation		Abutment and fillet dimensions							Weight
	electrically insulated	d	d _a min	d _a max	d _b min	D _a max	r _a max	r _b max	~
		mm							kg
NU1007M	NU1007M TM01	35	38,2	41,0	44,0	56	1,0	0,6	0,18
NU1008M	NU1008M TM01	40	43,2	45,0	49,0	63,4	1,0	0,6	0,23
NU1009M	NU1009M TM01	45	48,2	51,0	54,0	70,4	1,0	0,6	0,28
NU1010M	NU1010M TM01	50	53,2	56,0	60,0	75,4	1,0	6,0	0,30
NU1011M	NU1011M TM01	55	59,6	63,0	67,0	84	1,0	1,0	0,45
NU1012M	NU1012M TM01	60	64,6	68,0	72,0	89	1,0	1,0	0,48
NU1013M	NU1013M TM01	65	69,6	72,0	77,0	94	1,0	1,0	0,52
NU1014M	NU1014M TM01	70	74,6	78,0	82,0	104	1,0	1,0	0,70
NJ214EM	NU214EM TM01		77	82,0	86,0	116	1,5	1,5	1,30
NJ214EM	NJ214EM TM01		77	82,0	86,0	116	1,5	1,5	1,30
NU314EM	NU314EM TM01		81	85,0	92,0	138	2,0	2,0	3,10
NJ314EM	NJ314EM TM01		81	85,0	92,0	138	2,0	2,0	3,10
NU1015M	NU1015M TM01	75	79,6	83,0	87,0	109	1,0	1,0	0,74
NU215EM	NU215EM TM01		82	85,0	90,0	121	1,5	1,5	1,50
NJ215EM	NJ215EM TM01		82	85,0	90,0	121	1,5	1,5	1,50
NU315EM	NU315EM TM01		86	93,0	97,0	148	2,0	2,0	3,70
NJ315EM	NJ315EM TM01		86	93,0	97,0	148	2,0	2,0	3,70
NU1016M	NU1016M TM01	80	86	90,0	94,0	119	1,0	1,0	1,00
NU216EM	NU216EM TM01		90	92,0	97,0	130	2,0	2,0	1,70
NJ216EM	NJ216EM TM01		90	92,0	97,0	130	2,0	2,0	1,70
NU316EM	NU316EM TM01		99	97,0	105,0	158	2,0	2,0	4,50
NJ316EM	NJ316EM TM01		99	97,0	105,0	158	2,0	2,0	4,50
NU217EM	NU217EM TM01	85	95	99,0	104,0	140	2,0	2,0	2,10
NJ217EM	NJ217EM TM01		95	99,0	104,0	140	2,0	2,0	2,10
NU317EM	NU317EM TM01		98	103,0	110,0	166	2,5	2,5	5,30
NJ317EM	NJ317EM TM01		98	103,0	110,0	166	2,5	2,5	5,30
NU218EM	NU218EM TM01	90	100	105,0	109,0	150	2,0	2,0	2,60
NJ218EM	NJ218EM TM01		100	105,0	109,0	150	2,0	2,0	2,60
NU318EM	NU318EM TM01		103	110,0	116,0	176	2,5	2,5	6,10
NJ318EM	NJ318EM TM01		103	110,0	116,0	176	2,5	2,5	6,10



Single row cylindrical roller bearings for traction motors

d = 95 to 150 mm



NJ

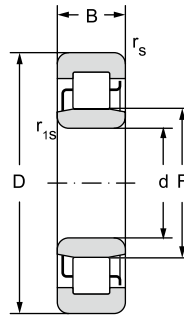

NU

12.11.2

Main dimensions							Basic load rating		Fatigue load limit	Limiting speed for lubrication with	
d	D	B	r _s min	r _{1s} min	F	s ₁	dynamická C _r	statická C _{or}	P _u	grease	oil
mm							kN		kN	min ⁻¹	
95	170	32,00	2,1	2,1	112,500	2,0	220,0	265,0	29,70	3800	4500
	170	32,00	2,1	2,1	112,500	2,0	220,0	265,0	29,70	3800	4500
	200	45,00	3,0	3,0	121,500	1,9	335,0	385,0	41,78	3000	3600
	200	45,00	3,0	3,0	121,500	1,9	335,0	385,0	41,78	3000	3600
100	180	34,00	2,1	2,1	119,000	2,0	249,0	305,0	33,62	3600	4300
	180	34,00	2,1	2,1	119,000	2,0	249,0	305,0	33,62	3600	4300
	215	47,00	3,0	3,0	127,500	2,0	380,0	425,0	45,23	2800	3400
	215	47,00	3,0	3,0	127,500	2,0	380,0	425,0	45,23	2800	3400
110	240	50,00	3,0	3,0	143,000	2,7	450,0	525,0	54,13	2600	3000
	240	50,00	3,0	3,0	143,000	2,7	450,0	525,0	54,13	2600	3000
120	260	55,00	3,0	3,0	154,000	2,7	530,0	610,0	61,36	2200	2800
	260	55,00	3,0	3,0	154,000	2,7	530,0	610,0	61,36	2200	2800
130	280	58,00	4,0	4,0	167,000	2,9	615,0	735,0	72,27	2200	2600
	280	58,00	4,0	4,0	167,000	2,9	615,0	735,0	72,27	2200	2600
140	300	62,00	4,0	4,0	180,000	2,7	665,0	795,0	76,53	2000	2400
	300	62,00	4,0	4,0	180,000	2,7	665,0	795,0	76,53	2000	2400
150	320	65,00	4,0	4,0	193,000	2,7	760,0	920,0	86,83	1800	2200
	320	65,00	4,0	4,0	193,000	2,7	760,0	920,0	86,83	1800	2200

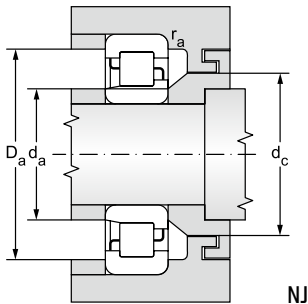

NJ

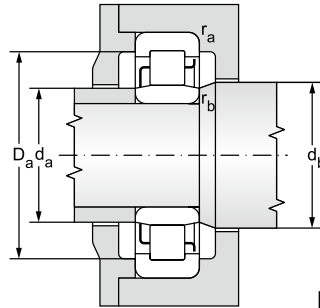

NU

¹⁾ Admissible axial movement

Bearing designation		Abutment and fillet dimensions							Weight
	electrically insulated	d	d _a min	d _a max	d _b min	D _a max	r _a max	r _b max	~
		mm							kg
NU219EM	NU219EM TM01	95	107	111,0	116,0	158	2,0	2,0	3,20
NJ219EM	NJ219EM TM01		107	111,0	116,0	158	2,0	2,0	3,20
NU319EM	NU319EM TM01		109	119,0	124,0	186	2,5	2,5	7,10
NJ319EM	NJ319EM TM01		109	119,0	124,0	186	2,5	2,5	7,10
NU220EM	NU220EM TM01	100	112	117,0	122,0	168	2,0	2,0	3,80
NJ220EM	NJ220EM TM01		112	117,0	122,0	168	2,0	2,0	3,80
NU320EM	NU320EM TM01		113	125,0	132,0	201	2,0	2,0	8,60
NJ320EM	NJ320EM TM01		113	125,0	132,0	201	2,0	2,0	8,60
NU322EM	NU322EM TM01	110	124	135,0	145,0	226	2,5	2,5	11,8
NJ322EM	NJ322EM TM01		124	135,0	145,0	226	2,5	2,5	11,8
NU324EM	NU324EM TM01	120	134	145,0	156,0	246	2,5	2,5	15,0
NJ324EM	NJ324EM TM01		134	145,0	156,0	246	2,5	2,5	15,0
NU326EM	NU326EM TM01	130	148	155,0	169,0	262	3,0	3,0	18,7
NJ326EM	NJ326EM TM01		148	155,0	169,0	262	3,0	3,0	18,7
NU328EM	NU328EM TM01	140	158	166,0	182,0	282	3,0	3,0	23,0
NJ328EM	NJ328EM TM01		158	166,0	182,0	282	3,0	3,0	23,0
NU330EM	NU330EM TM01	150	168	185,0	195,0	302	3,0	3,0	27,0
NJ330EM	NJ330EM TM01		168	185,0	195,0	302	3,0	3,0	27,0



Special single row rolling bearings for railway vehicle axles

d = 118 to 130 mm

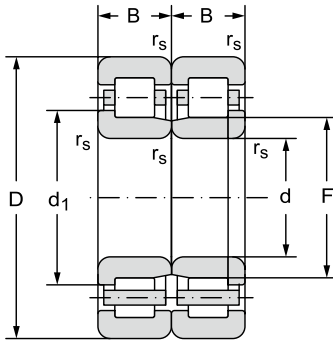

12.11.3

Main dimensions								Basic load rating		Fatigue load limit
d	D	B	r _s min	r _{1s} min	d ₁	d ₂	F	Dynamic C _r	Static C _{or}	P _u
mm								kN		kN
118	240	80	3	7,5	160,8		150	553	742	75,86
	240	80	3	7,5		160,8	150	553	742	75,86
119	240	80	3	7,5	160,8		150	553	742	75,86
	240	80	3	7,5		160,8	150	553	742	75,86
119,3	240	80	3	7,5	160,8		150	553	742	75,86
	240	80	3	7,5		160,8	150	553	742	75,86
120	200	62	2,1	2,1	148		140	371	565	57,76
	200	62	2,1	2,1		148	140	371	565	57,76
	240	80	3	7,5	160,8		150	553	742	75,86
	240	80	3	7,5	160,8		150	553	742	75,86
	240	80	3	7,5		160,8	150	553	742	75,86
	240	80	3	7,5		160,8	150	553	742	75,86
	215	73	3	2,1	150,8		140,5	520	730	76,26
	215	73	3	2,1		150,8	140,5	520	730	76,26
127	240	80	3	7,5	170,5		159	517	752	76,25
	240	80	3	7,5		170,5	159	517	752	76,25
128	240	80	3	7,5	170,5		159	517	752	76,25
	240	80	3	7,5		170,5	159	517	752	76,25
129	240	80	3	7,5	170,5		159	517	752	76,25
	240	80	3	7,5		170,5	159	517	752	76,25
	240	80	3	7,5	170,5		157	540	775	78,58
	240	80	3	7,5		170,5	157	540	775	78,58
129,3	240	80	3	7,5	170,5		157	540	775	78,58
	240	80	3	7,5		170,5	157	540	775	78,58
130	240	80	3	7,5	170,5		159	517	752	76,25
	240	80	3	7,5	170,5		159	517	752	76,25
	240	80	3	7,5		170,5	159	517	752	76,25
	240	80	3	7,5		170,5	159	517	752	76,25
	240	80	3	7,5	170,5		157	540	775	78,58
	240	80	3	7,5		170,5	157	540	775	78,58

Bearing designation	Maximum speed of rail vehicle	Radial clearance		Axial clearance		Weight	Precision class
		min.	max.	min.	max.		
	km.h ⁻¹	mm		mm		kg	
PLC 410-13.2.3	200	0,12	0,16	0,3	0,9	16,2	P6
PLC 410-14.2.3	200	0,12	0,16	0,3	0,9	16,2	P6
PLC 410-13.2.4	200	0,12	0,16	0,3	0,9	16,1	P6
PLC 410-14.2.4	200	0,12	0,16	0,3	0,9	16,1	P6
PLC 410-13.2.5	200	0,12	0,16	0,3	0,9	16,0	P6
PLC 410-14.2.5	200	0,12	0,16	0,3	0,9	16,0	P6
PLC 49-8	120	0,125	0,165	0,3	0,9	8,27	P0
PLC 49-9	120	0,125	0,165	0,3	0,9	8,27	P0
PLC 410-13	160	0,12	0,16	0,3	0,9	16,8	P6
PLC 410-13.2	200	0,12	0,16	0,3	0,9	16,0	P6
PLC 410-14	160	0,12	0,16	0,3	0,9	16,8	P6
PLC 410-14.2	200	0,12	0,16	0,3	0,9	16,0	P6
PLC 410-53.2	160	0,125	0,165	0,2	0,4	10,4	P0
PLC 410-54.2	160	0,125	0,165	0,2	0,4	10,4	P0
PLC 410-15.2.5	160	0,135	0,18	0,3	0,9	14,8	P0
PLC 410-16.2.5	160	0,135	0,18	0,3	0,9	14,8	P0
PLC 410-15.2.3	160	0,135	0,18	0,3	0,9	14,7	P0
PLC 410-16.2.3	160	0,135	0,18	0,3	0,9	14,7	P0
PLC 410-15.2.4	160	0,135	0,18	0,3	0,9	14,6	P0
PLC 410-16.2.4	160	0,135	0,18	0,3	0,9	14,6	P0
PLC 410-33.2.4	200	0,135	0,18	0,3	0,9	15,2	P6
PLC 410-34.2.4	200	0,135	0,18	0,3	0,9	15,2	P6
PLC 410-33.2.9	200	0,135	0,18	0,3	0,9	15,1	P6
PLC 410-34.2.9	200	0,135	0,18	0,3	0,9	15,1	P6
PLC 410-15	160	0,135	0,18	0,3	0,9	15,2	P0
PLC 410-15.2	160	0,135	0,18	0,3	0,9	14,5	P0
PLC 410-16	160	0,135	0,18	0,3	0,9	15,2	P0
PLC 410-16.2	160	0,135	0,18	0,3	0,9	14,5	P0
PLC 410-33.2	200	0,135	0,18	0,3	0,9	15,1	P6
PLC 410-34.2	200	0,135	0,18	0,3	0,9	15,1	P6



Double row spherical roller bearings for railway vehicle axles $d = 100$ to 190 mm

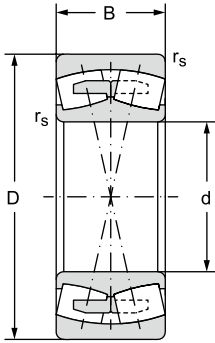

12.11.4

Main dimensions						Basic load rating		Fatigue load limit	Limiting speed for lubrication with	
d	D	B	r _s min	a	b	Dynamic C _r	Static C _{or}	P _u	grease	oil
mm						kN		kN	min ⁻¹	
100	180	60,3	2,1	4,5	8,3	390	532	67	1700	2000
110	200	69,8	2,1	4,5	8,3	502	706	75,5	1500	1800
120	215	76	2,1	4,5	8,3	750	1020	107	1500	1900
	215	58	2,1	4,5	8,3	439	580	60,6	1600	1900
130	230	80	3	6	11,1	636	948	96,9	1300	1600
	280	93	4	7,5	13,9	904	1130	111	1300	1600
140	210	53	2	4,5	8,3	511	781	80,5	1800	2400
	250	68	3	6	11,1	605	822	82	1400	1700
170	310	110	4	7,5	13,9	1280	1880	176	950	1300
190	290	75	2,1	6	11,1	759	1310	123	940	1200
	340	120	4	9	16,7	1550	2420	220	850	1100

Bearing designation	Abutment and fillet dimensions			Weight	Factors			
	d_a min	D_a max	r_a max		e	Y_1	Y_2	Y_0
	mm			kg				
23220W33M	112	168	2	6,9	0,34	2	2,8	1,9
23222W33M	122	188	2	9,9	0,36	1,9	2,7	1,8
23224EW33MH	132	203	2	12,1	0,33	2	3	2
22224W33M	132	203	2	9,4	0,28	2,4	3,4	2,3
23226W33M	144	216	2,5	15	0,35	1,9	2,7	1,8
22326W33M	148	262	3	28,6	0,36	1,8	2,7	1,8
23028EW33MH	150	200	2	6,58	0,22	3	4,5	3
22228W33M	154	236	2,5	15	0,28	2,4	3,4	2,2
23234W33M	188	292	3	37,7	0,36	1,9	2,8	1,8
23038W33M	202	278	2	18,8	0,25	2,7	3,8	2,5
23238CW33M	208	322	3	47,7	0,36	1,9	2,8	1,9



Tapered bearing units TBU

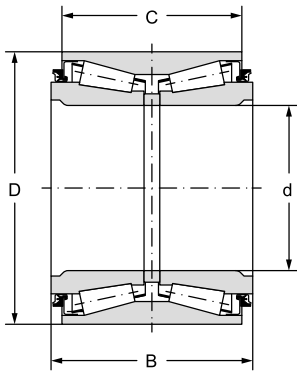

12.11.5

Main dimensions				Basic load rating		Fatigue load limit
d	D	C	B	Dynamic C_r	Static C_{or}	P_u
mm				kN		kN
130	230	160	176,35	913	1620	165,62
	210	132	148	658	1260	131

Bearing designation	Equivalent	Maximum speed of rail vehicle	Weight
		max	
		km.h ⁻¹	kg
PLC 810-13	CTBU 130x230	160	31,7
PLC 810-15	CTBU 130x210	100	18







12.12 SPECIAL ROLLER BEARINGS

- Hybrid bearings
- Electrically insulated bearings
- Split bearings
- Other special bearings

HYBRID BEARINGS

Hybrid bearings have races made of bearing steel and rolling elements made of silicon nitride (Si_3N_4). Hybrid bearings feature excellent electrical insulation properties that apply mainly in the area of electric motors. Silicon nitride rolling elements prevents passage of current through the bearings which protects also the bearing rings against damage by electric current.

Silicon nitride has also significantly lower density than steel which takes effects mainly at high revolutions by reduction of centrifugal forces which reduces tension of outer ring. This has positive effect to the durability of high rpm bearings. It also reduces inertial forces which takes effect mostly in sudden changes of revolution frequency. Lower inertial forces of rolling elements load cage partitions significantly less, comparing to the standard steel elements.

Silicon nitride has higher elasticity module than bearing steel. This takes effect in contact area by lower contact surface resulting in reduction of rolling and sliding friction. Along with lower weight of ceramic elements and lower centrifugal forces, friction can be reduced at high revolutions. Friction in bearing is closely related to the service temperature of bearing. The lower the friction factor in the bearing, the lower the service temperature. Hybrid bearings are therefore suitable for applications with high revolution frequencies.

Hybrid bearings are capable of operation at low service viscosity since in contact of hybrid rings and silicon nitride elements no abrasion occurs. Hybrid bearings are suitable also in operations where bearings operate at very big dynamic stress, or when bearings are greased only with a very thin lubrication film. Hybrid bearings are used in locations where vibrations act, or where bearings perform oscillation movements only.

Silicon nitride also features lower thermal ductility; bearing is thus less sensitive to temperature changes.

Availability of hybrid bearings has to be discussed with the supplier.



Hybrid ball bearings

Single row hybrid ball bearings are among the most frequently used hybrid bearings which find their application in electric motors. Their construction is very easy and they are able to transfer radial and axial load in both directions.

Hybrid ball bearings are made in dimensions with bore diameter between 10 to 120 mm. Bearings with bigger dimensions can be made upon customer's request. Hybrid bearings for electric motors are made in rows 60, 62 and 63 as uncovered bearings. Standard design is of normal accuracy P0; upon request hybrid bearings can be supplied in accuracy P6 and P5.

Bearing rings are made of the same steel as the one used for all-steel bearings. In standard version bearing are made in dimension stabilisation S0 for operation up to the temperatures of 150 °C. Upon request bearings can be supplied with dimension stabilisation S1 for operation up to the temperatures of 200 °C. In other cases consult the technical and consultancy services of ZKL.



Fig. 12.12.1

Main dimensions

As standard, hybrid ball bearings are made according to dimensional plan ISO 15.

Radial clearance

Radial clearances of hybrid ball bearings are the same as clearances of all-steel bearings and comply with ISO 5753. For use in electric and traction motors, bearings with radial clearance C3 are used most of the time.

Misalignment

Hybrid ball bearings do not suit compensation of misalignment. Depending on radial clearance, bearing dimensions and forces acting on bearing, admissible tilting of bearing ranges between 2 to 10 angular minutes. Tilting of inner race against outer ring causes excessive noise and reduces service life of bearing.

Cages

Hybrid ball bearings are mostly made with metal cages. Some applications utilise polyamide cages that only suit in temperatures to 120 °C. Standard cages are in the same design as for common ball bearings, are stated in chapter 7.4:

- Two-piece riveted steel plate cage guided by balls (is not designated)
- Two-piece riveted massive brass cage guided on the external race (MA)
- Single-piece polyamide cage reinforced with fibre glasses guided by balls (TNG).

Minimum load

Hybrid ball bearings are more resistant to damage of raceways caused by slippage in sufficient loading. Comparing to common steel bearings, they can provide reliable run with lower minimum load. Therefore these bearings also suit locations where very small or variable load acts on bearings.

Axial load rating

Bearing must not be exposed to purely axial load exceeding 50% C_{Dr} . Small bearings and light rows must not be exposed to axial load exceeding 25% C_{Dr} . If the above stated values are exceeded, the service life of bearing reduces dramatically.

Equivalent dynamic and static load of bearing

Equivalent dynamic and static load of bearing is calculated same as for common all-steel ball bearing, see chapter Single row ball bearings.

Designation of hybrid ball bearings

Hybrid ball bearings have the same designation system as standard all-steel ball bearings. Use of ceramics on bearing components is characterised with an additional "C" character before the bearing designation, e.g.: C 6213MA.

Hybrid cylindrical roller bearings

Hybrid cylindrical roller bearings are located where bearings are loaded with big radial load and where hybrid ball bearings can no longer be used due to their lower dynamic load capacity. Hybrid cylindrical roller bearings are made in standard dimensions complying with ISO 15. Hybrid cylindrical roller bearings are made in designs with two-piece massive brass cage guided on outer ring (MA), another cage design has to be consulted with the supplier.

Hybrid cylindrical roller bearings have the same designation system as standard all-steel roller bearings with the only difference of having the „C" character before the designation of the bearing, e.g.: C NU312MA. Availability and details on these bearings are available at the technical and consultancy services of ZKL.



ELECTRICALLY INSULATED BEARINGS

Bearings in electric motors and generators, together with related equipment might get damages due to passage of electric current that participates in damaging the raceways of rings and rolling elements, causing fast degradation of the lubricant used.

Bearings are supplied with insulating ceramic spray application (Al_2O_3) on the outer ring surface; the aluminium oxide thickness is 0.15 mm. Bearings insulated in the above described manner are capable of resisting to DC voltage up to 1000 V. The spray application is coated thermally on the outer surface of the outer ring, and complies with the requirements for surface hardness and adhesion to the surface the spray is applied on.

These bearings have an additional designation TM01, e.g.: NU1012M TM01. In the designation means

- TM bearing with thermal insulation spray application (always in combination with a pair of characters for the layer characteristics)
- 0 Al_2O_3 spray application with minimum resistance of 50 M Ω at DC voltage of 1000 V
- 1 ceramic spray application on the outer ring surface (2 on inner race, 3 on both races).

Mostly used are single row ball bearings and single row cylindrical roller bearings. Bearings insulated with aluminium oxide have the same dimensions and design as standard bearings. Dimensions of ball and cylindrical roller bearings with Al_2O_3 layer correspond with the ISO 15 dimensional plan. The availability of electrically insulated bearings has to be consulted with the supplier.

Standard design is that of normal accuracy P0; upon request the bearings can be supplied even in higher accuracy P6 and P5. The bearings are made in normal radial clearance or, upon request, in bigger radial clearances C3 and C4. Radial clearances are stated in tables 7.17a for single row ball bearings and 7.19 for single row cylindrical roller bearings.

Electrically insulated bearings are made mostly with a two-piece massive brass cage guided on rolling elements, or with a two-piece steel plate cage guided on rolling elements. In some cases, especially in smaller bearings, a single-piece plastic cage reinforced with fibre glass is used.

Other properties of electrically insulated bearings are identical to those of common bearings; detailed information on these bearings is available in individual chapters on single row ball bearings and single row cylindrical roller bearings.

The table section states the most common electrically insulated bearings. Please consult delivery of bearings of different dimensions and types with the supplier.



Fig. 12.12.2

SPECIAL ZKL BEARINGS

Besides standardised bearings in basic and different designs stated in this catalogue, ZKL supplies also special roller bearings. They usually feature non-standardised dimensions and cannot be included in standardised series. Production of special bearings often utilises different materials. These bearings are purposefully designed for applications in machines and equipment where the construction does not allow use of standardised bearings. The dimensions and basic parameters of the bearings are stated in the table section.

OTHER SPECIAL BEARINGS

ZKL manufactures additional type and dimensional series of bearings, parameters of which are not listed in this catalogue. More detailed information about special ZKL bearings is available in professional company publications. Use of special roller bearings is mainly recommended in more demanding cases of location, and supplies of bearings, their locations and assembly should be consulted with the supplier. Further information on special roller bearings is available at the ZKL technical and consultancy services.



Multi row roller bearings

They are used to capture extremely big radial forces with limited build-up dimensions, mainly in smelting industry for location of rolling mill rollers. Rings of these bearings are provided with lubrication holes to ensure supply of lubricant in all roller rows.

Fig. 12.12.3

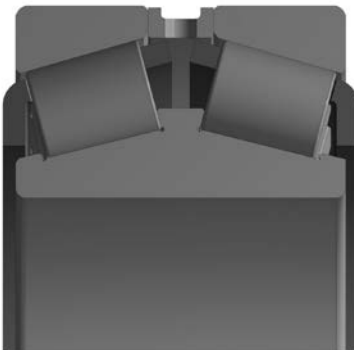

Single row and double row tapered roller bearings

They are used mainly in automotive industry and in heavy machinery.

obr. 12.12.4



Double and four row tapered roller bearings

They are used to locate rolling mill rollers and rollers of other plants in steel rolling mills. They are manufactured with axial clearance the size of which is determined upon the service conditions.

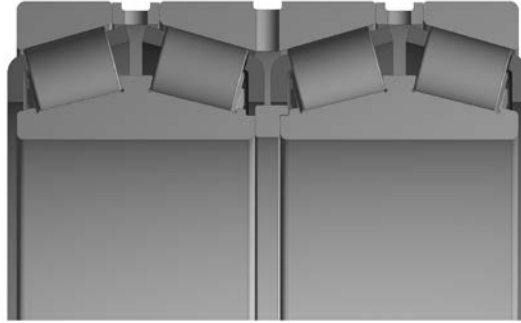

Fig. 12.12.5

Crossed roller bearings

In standard design, crossed roller bearings are compact two ring bearings with cross arrangement of rollers in raceway between the inner and outer ring. In majority of cases, rollers are separated with plastic separators or alternatively with a massive or segment cage. The contact angle of raceway is usually 45° . The bearings are supplied with clearance or prestress, depending on the use. Bearing rings are provided with bores for fixing bolts. Inner space is protected with rubber sealing to prevent excessive leak of grease from the bearing and penetration of impurities inside the bearing.

It is manufactured with outer diameter between 300 to 1 600 mm, and with inner or outer gearing or – more precisely – without gearing for location of building and earth-moving machinery, robots and manipulators, machine tools, mining combine harvesters, stamp plates, wind power plants, rotary furnaces and mill mixers.



Fig. 12.12.6



Large size ball bearings with four-point contact and double row ball bearings with angular contact

Bearings suitable for continuously rotating plants and also for machines with cyclic operation character of medium sizes, such as excavators and cranes. To ensure higher revolution frequency, bearings with massive or segment cage are made. They have a relatively low friction torque. The rigidity of location with the use of ball bearings is lower than that of bearings with crossed rollers. Usually they have a contact angle of 45° . They are manufactured with outer diameter ranging between 300 and 1600 with inner or outer gearing or – more precisely – without gearing.

Fig. 12.12.7

Double direction cylindrical roller and tapered thrust bearings

They are used to capture big radial forces in rolling mill rollers' locations, and also where high rigidity in axial direction is required, mainly in locations of carousel desks.

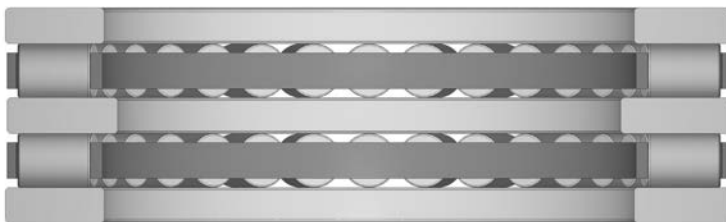
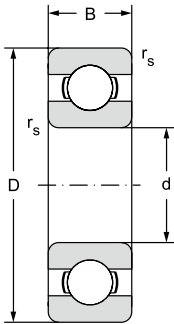

Fig. 12.12.8



Hybrid ball bearings d = 10 to 120 mm

d = 10 to 55 mm



12.12.1

Main dimensions				Basic load rating		Fatigue load limit
d	D	B	r _s	dynamic C _r	static C _{0r}	P _u
mm				kN		kN
10	26	8,0	0,3	4,56	1,96	0,089
	30	9,0	0,6	6,05	2,51	0,114
12	28	8,0	0,3	5,09	2,36	0,107
	32	10,0	0,6	6,91	3,10	0,141
15	32	9,0	0,3	5,59	2,87	0,130
	35	11,0	0,6	7,72	3,75	0,170
17	35	10,0	0,3	6,00	3,27	0,149
	40	12,0	0,6	9,53	4,73	0,215
20	42	12,0	0,6	9,37	4,97	0,226
	47	14,0	1,0	12,77	6,55	0,298
25	47	12,0	0,6	10,07	5,81	0,264
	52	15,0	1,0	14,03	7,94	0,361
30	55	13,0	1,0	13,24	8,25	0,375
	62	16,0	1,0	19,44	11,19	0,508
35	62	14,0	1,0	15,96	10,33	0,469
	72	17,0	1,1	25,66	15,23	0,692
40	68	15,0	1,0	16,82	11,49	0,522
	80	18,0	1,1	32,63	19,89	0,904
	90	23,0	1,5	40,76	24,17	1,099
45	75	16,0	1,0	21,10	15,30	0,695
	85	19,0	1,1	32,68	20,33	0,924
	100	25,0	1,5	52,80	31,72	1,442
50	80	16,0	1,0	21,72	16,65	0,757
	90	20,0	1,1	35,07	23,23	1,056
	110	27,0	2,0	61,75	37,75	1,716
55	90	18,0	1,1	28,22	21,32	0,969
	100	21,0	1,5	43,35	29,40	1,336
	120	29,0	2,0	71,00	44,70	2,032

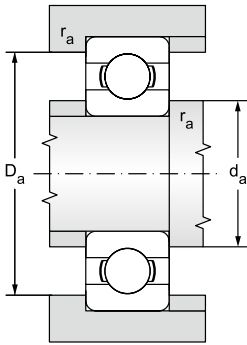

Limiting speed for lubrication with		Bearing designation	Abutment and fillet dimensions			Weight ~ kg
grease	oil		d _a min	D _a max	r _a max	
min ⁻¹			mm			
28000	33000	C 6000	12,0	24,0	0,3	0,018
25000	30000	C 6200	14,0	26,0	0,6	0,031
25000	30000	C 6001	14,0	26,0	0,3	0,022
22000	27000	C 6201	16,0	28,0	0,6	0,037
21000	25000	C 6002	17,0	30,0	0,3	0,030
20000	24000	C 6202	19,0	31,0	0,6	0,044
20000	24000	C 6003	19,0	33,0	0,3	0,040
18000	21000	C 6203	21,0	36,0	0,6	0,073
17000	20000	C 6004	24,0	38,0	0,6	0,070
15000	18000	C 6204	25,0	42,0	1,0	0,11
14000	17000	C 6005	28,0	43,0	0,6	0,082
12000	15000	C 6205	30,0	47,0	1,0	0,13
12000	14000	C 6006	34,0	50,0	1,0	0,12
11000	13000	C 6206	35,0	57,0	1,0	0,20
10600	12600	C 6007	39,5	57,0	1,0	0,15
9400	11000	C 6207	42,0	65,0	1,0	0,28
9400	11000	C 6008	44,0	63,0	1,0	0,19
8400	10000	C 6208	47,0	73,0	1,0	0,35
7900	9400	C 6308	47,0	81,0	1,5	0,63
8400	10000	C 6009	49,0	70,0	1,0	0,24
7900	9400	C 6209	52,0	78,0	1,0	0,40
7100	8400	C 6309	52,0	91,0	1,5	0,83
7900	9400	C 6010	54,0	75,0	1,0	0,26
7100	8400	C 6210	57,0	83,0	1,0	0,46
6300	7500	C 6310	60,0	100,0	2,0	1,06
7100	8400	C 6011	60,0	84,0	1,0	0,38
6700	7900	C 6211	62,0	91,0	1,5	0,60
5600	6700	C 6311	65,0	110,0	2,0	1,38



Hybrid ball bearings

d = 60 to 120 mm

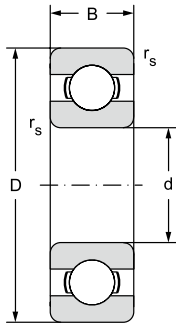

12.12.1

Main dimensions				Basic load rating		Fatigue load limit
d	D	B	r _s	dynamic C _r	static C _{0r}	P _u
mm				kN		kN
60	110	22,0	1,5	52,85	35,79	1,627
	130	31,0	2,1	81,50	52,10	2,368
65	120	23,0	1,5	57,21	40,01	1,819
	140	33,0	2,1	92,60	59,60	2,676
70	125	24,0	1,5	62,00	43,80	1,991
	150	35,0	2,1	104,00	63,10	2,735
75	130	25,0	1,5	66,18	49,31	2,214
	160	37,0	2,1	114,00	76,40	3,204
80	140	26,0	2,0	72,20	53,10	2,301
	170	37,0	2,1	122,85	86,23	3,506
85	150	28,0	2,0	83,30	63,68	2,670
	180	41,0	3,0	132,51	96,07	3,794
90	160	30,0	2,0	96,20	70,80	2,878
	190	43,0	3,0	144,00	108,00	4,149
95	170	32,0	2,1	108,00	81,00	3,199
	200	45,0	3,0	152,44	117,37	4,393
100	180	34,0	2,1	123,00	92,60	3,557
	215	47,0	3,0	174,00	141,00	5,107
105	190	36,0	2,1	132,93	104,83	3,924
110	200	38,0	2,1	144,00	117,00	4,272
120	215	40,0	2,1	144,00	117,00	4,109

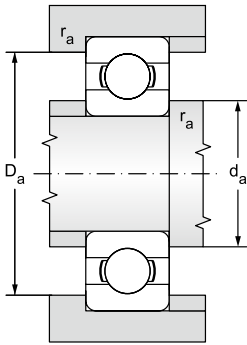

Limiting speed for lubrication with		Bearing designation	Abutment and fillet dimensions			Weight ~ kg
grease	oil		d_a min	D_a max	r_a max	
min ⁻¹			mm			
6000	7100	C 6212MA	67,0	101,0	1,5	0,77
5300	6300	C 6312MA	72,0	118,0	2,0	1,72
5300	6300	C 6213MA	72,0	111,0	1,5	1,00
5000	6000	C 6313MA	76,0	128,0	2,0	2,10
5300	6300	C 6214MA	77,0	116,0	1,5	1,07
4700	5600	C 6314MA	81,0	138,0	2,0	2,54
5000	6000	C 6215MA	82,0	122,0	1,5	1,18
4200	5000	C 6315MA	86,0	148,0	2,0	3,06
4700	5600	C 6216MA	90,0	130,0	2,0	1,40
4000	4700	C 6316MA	91,0	158,0	2,0	3,63
4200	5000	C 6217MA	95,0	140,0	2,0	1,80
3800	4500	C 6317MA	98,0	166,0	2,5	4,20
4000	4700	C 6218MA	100,0	150,0	2,0	2,16
3500	4200	C 6318MA	103,0	176,0	2,5	4,95
3800	4500	C 6219MA	107,0	158,0	2,0	2,60
3300	4000	C 6319MA	109,0	186,0	2,5	5,72
3500	4200	C 6220MA	112,0	169,0	2,0	3,13
3200	3800	C 6320MA	113,0	201,0	2,5	7,07
3300	4000	C 6221MA	117,0	178,0	2,0	3,74
3200	3800	C 6222MA	122,0	188,0	2,0	4,37
3000	3500	C 6224MA	132,0	203,0	2,0	5,15



Electrically insulated ball bearings d = 70 to 150 mm

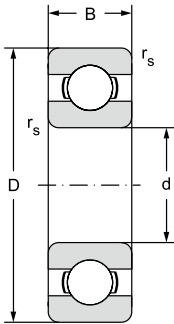

12.12.2

Main dimensions				Basic load rating		Fatigue load limit
d	D	B	r _s	dynamic C _r	static C _{0r}	P _u
mm				kN		kN
70	125	24,0	1,5	62,00	43,80	1,991
	150	35,0	2,1	104,00	63,10	2,735
75	130	25,0	1,5	66,18	49,31	2,214
	160	37,0	2,1	114,00	76,40	3,204
80	140	26,0	2,0	72,20	53,10	2,301
	170	37,0	2,1	122,85	86,23	3,506
85	150	28,0	2,0	83,30	63,68	2,670
	180	41,0	3,0	132,51	96,07	3,794
90	160	30,0	2,0	96,20	70,80	2,878
	190	43,0	3,0	144,00	108,00	4,149
95	170	32,0	2,1	108,00	81,00	3,199
	200	45,0	3,0	152,44	117,37	4,393
100	180	34,0	2,1	123,00	92,60	3,557
	215	47,0	3,0	174,00	141,00	5,107
110	200	38,0	2,1	144,00	117,00	4,272
	240	50,0	3,0	203,00	180,00	6,185
120	215	40,0	2,1	144,00	117,00	4,109
	260	55,0	3,0	208,00	186,00	6,134
130	230	40,0	3,0	156,00	132,00	4,472
	280	58,0	4,0	229,00	216,00	6,857
140	250	42,0	3,0	166,00	150,00	4,883
	300	62,0	4,0	251,00	245,00	7,508
150	270	45,0	3,0	190,00	181,00	5,677
	320	65,0	4,0	276,00	285,00	8,451

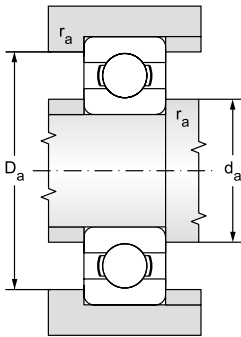

Limiting speed for lubrication with		Bearing designation	Abutment and fillet dimensions			Weight ~ kg
grease	olejem		d _a min	D _a max	r _a max	
min ⁻¹			mm			
5300	6300	6214M TM01	77,0	116,0	1,5	1,07
4700	5600	6314M TM01	81,0	138,0	2,0	2,54
5000	6000	6215M TM01	82,0	122,0	1,5	1,18
4200	5000	6315M TM01	86,0	148,0	2,0	3,06
4700	5600	6216M TM01	90,0	130,0	2,0	1,40
4000	4700	6316M TM01	91,0	158,0	2,0	3,63
4200	5000	6217M TM01	95,0	140,0	2,0	1,80
3800	4500	6317M TM01	98,0	166,0	2,5	4,20
4000	4700	6218M TM01	100,0	150,0	2,0	2,16
3500	4200	6318M TM01	103,0	176,0	2,5	4,95
3800	4500	6219M TM01	107,0	158,0	2,0	2,60
3300	4000	6319M TM01	109,0	186,0	2,5	5,72
3500	4200	6220M TM01	112,0	169,0	2,0	3,13
3200	3800	6320M TM01	113,0	201,0	2,5	7,07
3200	3800	6222M TM01	122,0	188,0	2,0	4,37
2600	3200	6322M TM01	123,0	227,0	2,5	9,58
3000	3500	6224M TM01	132,0	203,0	2,0	5,15
2500	3000	6324M TM01	134,0	246,0	2,5	12,5
2600	3100	6226M TM01	144,0	216,0	2,5	5,75
2350	2800	6326M TM01	147,0	263,0	3,0	15,2
2500	3000	6228M TM01	154,0	236,0	2,5	7,56
2350	2800	6328M TM01	157,0	283,0	3,0	21,8
2200	2700	6230M TM01	164,0	256,0	2,5	9,85
2000	2400	6330M TM01	167,0	303,0	3,0	24,0



Electrically insulated cylindrical roller bearings d = 70 to 150 mm

d = 70 to 100 mm

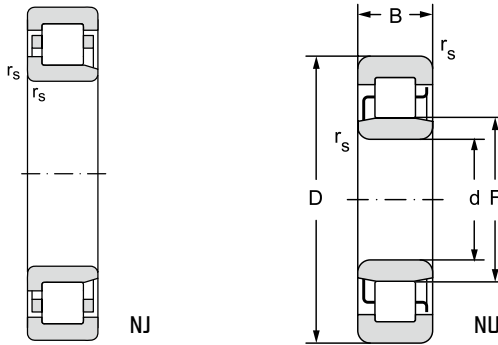

12.12.3

Main dimensions							Bearing designation	Basic load rating	
d	D	B	r _s min	r _{1s} min	F	s ₁₎		dynamic C _r	static C _{or}
mm							kN		
70	125	24,00	1,5	1,5	83,500	1,6	NU214EM TM01	119,0	137,0
	125	24,00	1,5	1,5	83,500	1,6	NJ214EM TM01	119,0	137,0
	125	31,00	1,5	1,5	83,500	1,6	NU2214EM TM01	156,0	194,0
	125	31,00	1,5	1,5	83,500	1,6	NJ2214EM TM01	156,0	194,0
	150	35,00	2,1	2,1	89,000	1,5	NU314EM TM01	205,0	222,0
	150	35,00	2,1	2,1	89,000	1,5	NJ314EM TM01	205,0	222,0
75	130	25,00	1,5	1,5	88,500	1,6	NU215EM TM01	130,0	156,0
	130	25,00	1,5	1,5	88,500	1,6	NJ215EM TM01	130,0	156,0
	130	31,00	1,5	1,5	88,500	2,1	NU2215EM TM01	162,0	207,0
	130	31,00	1,5	1,5	88,500	2,1	NJ2215EM TM01	162,0	207,0
	160	37,00	2,1	2,1	95,000	1,5	NU315EM TM01	240,0	263,0
	160	37,00	2,1	2,1	95,000	1,5	NJ315EM TM01	240,0	263,0
80	140	26,00	2,0	2,0	95,300	2,0	NU216EM TM01	139,0	167,0
	140	26,00	2,0	2,0	95,300	2,0	NJ216EM TM01	139,0	167,0
	170	39,00	2,1	2,1	101,000	1,5	NU316EM TM01	256,0	282,0
	170	39,00	2,1	2,1	101,000	1,5	NJ316EM TM01	256,0	282,0
85	150	28,00	2,0	2,0	100,500	2,0	NU217EM TM01	167,0	199,0
	150	28,00	2,0	2,0	100,500	2,0	NJ217EM TM01	167,0	199,0
	180	41,00	3,0	3,0	108,000	2,0	NU317EM TM01	291,0	330,0
	180	41,00	3,0	3,0	108,000	2,0	NJ317EM TM01	291,0	330,0
90	160	30,00	2,0	2,0	107,000	2,0	NU218EM TM01	182,0	217,0
	160	30,00	2,0	2,0	107,000	2,0	NJ218EM TM01	182,0	217,0
	190	43,00	3,0	3,0	113,500	2,0	NU318EM TM01	315,0	355,0
	190	43,00	3,0	3,0	113,500	2,0	NJ318EM TM01	315,0	355,0
95	170	32,00	2,1	2,1	112,500	2,0	NU219EM TM01	220,0	265,0
	170	32,00	2,1	2,1	112,500	2,0	NJ219EM TM01	220,0	265,0
	200	45,00	3,0	3,0	121,500	1,9	NU319EM TM01	335,0	385,0
	200	45,00	3,0	3,0	121,500	1,9	NJ319EM TM01	335,0	385,0
100	180	34,00	2,1	2,1	119,000	2,0	NU220EM TM01	249,0	305,0
	180	34,00	2,1	2,1	119,000	2,0	NJ220EM TM01	249,0	305,0
	215	47,00	3,0	3,0	127,500	2,0	NU320EM TM01	380,0	425,0
	215	47,00	3,0	3,0	127,500	2,0	NJ320EM TM01	380,0	425,0

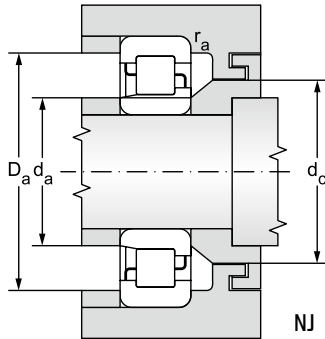

NJ

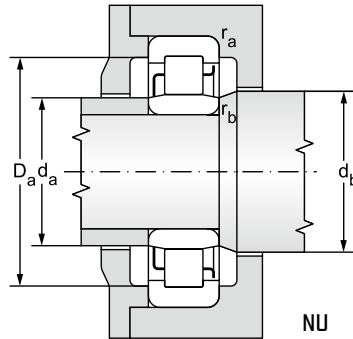

NU

¹⁾ Admissible axial movement

Fatigue load limit	Limiting speed for lubrication with		Abutment and fillet dimensions							Weight
	grease	oil	d	d _a min	d _a max	d _b min	D _a max	r _a max	r _b max	
P _u	min ⁻¹		mm							kg
16,71	5000	6300	70	77	82,0	86,0	116	1,5	1,5	1,30
16,71	5000	6300		77	82,0	86,0	116	1,5	1,5	1,30
23,66	4500	5600		77	82,0	86,0	116	1,5	1,5	1,50
23,66	4500	5600		77	82,0	86,0	116	1,5	1,5	1,50
26,31	4000	5000		81	85,0	92,0	138	2,0	2,0	3,10
26,31	4000	5000		81	85,0	92,0	138	2,0	2,0	3,10
18,88	4800	6000	75	82	85,0	90,0	121	1,5	1,5	1,50
18,88	4800	6000		82	85,0	90,0	121	1,5	1,5	1,50
25,06	4300	5300		82	85,0	90,0	121	1,5	1,5	1,60
25,06	4300	5300		82	85,0	90,0	121	1,5	1,5	1,60
30,56	3800	4800		86	93,0	97,0	148	2,0	2,0	3,70
30,56	3800	4800		86	93,0	97,0	148	2,0	2,0	3,70
19,79	4500	5300	80	90	92,0	97,0	130	2,0	2,0	1,70
19,79	4500	5300		90	92,0	97,0	130	2,0	2,0	1,70
32,16	3600	4300		99	97,0	105,0	158	2,0	2,0	4,50
32,16	3600	4300		99	97,0	105,0	158	2,0	2,0	4,50
23,12	4300	5000	85	95	99,0	104,0	140	2,0	2,0	2,10
23,12	4300	5000		95	99,0	104,0	140	2,0	2,0	2,10
36,99	3300	4000		98	103,0	110,0	166	2,5	2,5	5,30
36,99	3300	4000		98	103,0	110,0	166	2,5	2,5	5,30
24,75	4000	4800	90	100	105,0	109,0	150	2,0	2,0	2,60
24,75	4000	4800		100	105,0	109,0	150	2,0	2,0	2,60
39,14	3200	3800		103	110,0	116,0	176	2,5	2,5	6,10
39,14	3200	3800		103	110,0	116,0	176	2,5	2,5	6,10
29,70	3800	4500	95	107	111,0	116,0	158	2,0	2,0	3,20
29,70	3800	4500		107	111,0	116,0	158	2,0	2,0	3,20
41,78	3000	3600		109	119,0	124,0	186	2,5	2,5	7,10
41,78	3000	3600		109	119,0	124,0	186	2,5	2,5	7,10
33,62	3600	4300	100	112	117,0	122,0	168	2,0	2,0	3,80
33,62	3600	4300		112	117,0	122,0	168	2,0	2,0	3,80
45,23	2800	3400		113	125,0	132,0	201	2,0	2,0	8,60
45,23	2800	3400		113	125,0	132,0	201	2,0	2,0	8,60



Electrically insulated cylindrical roller bearings

d = 110 to 150 mm

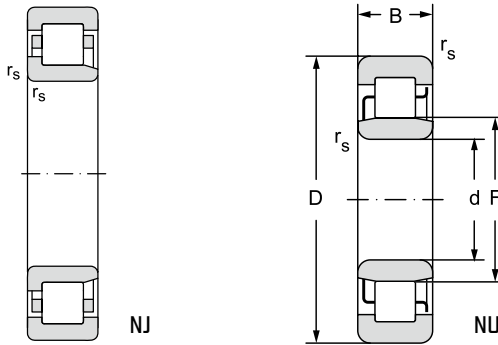

12.12.3

Main dimensions							Bearing designation	Basic load rating	
d	D	B	r _s min	r _{1s} min	F	s ₁		dynamic C _r	static C _{or}
mm							kN		
110	200	38,00	2,1	2,1	132,500	2,5	NU222EM TM01	293,0	365,0
	200	38,00	2,1	2,1	132,500	2,5	NJ222EM TM01	293,0	365,0
	240	50,00	3,0	3,0	143,000	2,7	NU322EM TM01	450,0	525,0
	240	50,00	3,0	3,0	143,000	2,7	NJ322EM TM01	450,0	525,0
120	180	28,00	2,0	1,1	135,000	2,0	NU1024M TM01	131,0	168,0
	215	40,00	2,1	2,1	143,500	2,5	NU224EM TM01	335,0	420,0
	215	40,00	2,1	2,1	143,500	2,5	NJ224EM TM01	335,0	420,0
	260	55,00	3,0	3,0	154,000	2,7	NU324EM TM01	530,0	610,0
	260	55,00	3,0	3,0	154,000	2,7	NJ324EM TM01	530,0	610,0
130	200	33,00	2,0	1,1	148,000	2,0	NU1026M TM01	162,0	203,0
	230	40,00	3,0	3,0	153,500	2,5	NU226EM TM01	365,0	455,0
	230	40,00	3,0	3,0	153,500	2,5	NJ226EM TM01	365,0	455,0
	280	58,00	4,0	4,0	167,000	2,9	NU326EM TM01	615,0	735,0
	280	58,00	4,0	4,0	167,000	2,9	NJ326EM TM01	615,0	735,0
140	210	33,00	2,0	1,1	158,000	2,0	NU1028M TM01	176,0	250,0
	250	42,00	3,0	3,0	169,000	2,5	NU228EM TM01	395,0	515,0
	250	42,00	3,0	3,0	169,000	2,5	NJ228EM TM01	395,0	515,0
	300	62,00	4,0	4,0	180,000	2,7	NU328EM TM01	665,0	795,0
	300	62,00	4,0	4,0	180,000	2,7	NJ328EM TM01	665,0	795,0
150	225	35,00	2,1	1,5	169,500	2,0	NU1030M TM01	192,0	251,0
	270	45,00	3,0	3,0	182,000	2,4	NU230EM TM01	450,0	595,0
	270	45,00	3,0	3,0	182,000	2,4	NJ230EM TM01	450,0	595,0
	320	65,00	4,0	4,0	193,000	2,7	NU330EM TM01	760,0	920,0
	320	65,00	4,0	4,0	193,000	2,7	NJ330EM TM01	760,0	920,0

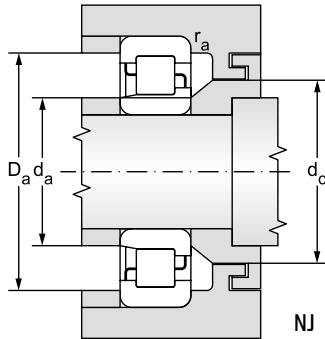

NJ

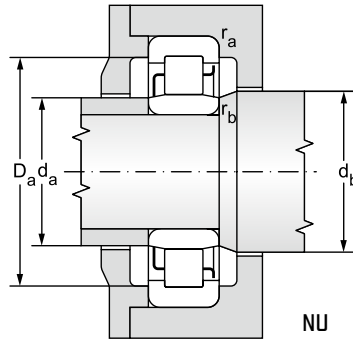

NU

¹⁾ Admissible axial movement

Fatigue load limit	Limiting speed for lubrication with		Abutment and fillet dimensions							Weight
	grease	oil	d	d _a min	d _a max	d _b min	D _a max	r _a max	r _b max	
P _u	min ⁻¹		mm							kg
39,03	3200	3800	110	122	125,0	135,0	188	2,0	2,0	5,40
39,03	3200	3800		122	125,0	135,0	188	2,0	2,0	5,40
54,13	2600	3000		124	135,0	145,0	226	2,5	2,5	11,8
54,13	2600	3000		124	135,0	145,0	226	2,5	2,5	11,8
18,14	3300	4000	120	128	131,0	138,0	171	2,0	1,0	2,45
43,88	3000	3400		132	138,0	146,0	203	2,0	2,0	6,40
43,88	3000	3400		132	138,0	146,0	203	2,0	2,0	6,40
61,36	2200	2800		134	145,0	156,0	246	2,5	2,5	15,0
61,36	2200	2800		134	145,0	156,0	246	2,5	2,5	15,0
21,30	3200	3800	130	138	143,0	151,0	191	2,0	1,0	3,75
46,52	2600	3200		144	150,0	158,0	216	2,5	2,5	8,00
46,52	2600	3200		144	150,0	158,0	216	2,5	2,5	8,00
72,27	2200	2600		148	155,0	169,0	262	3,0	3,0	18,7
72,27	2200	2600		148	155,0	169,0	262	3,0	3,0	18,7
25,78	3000	3600	140	149	153,0	161,0	201	2,0	1,0	3,90
51,40	2400	3000		154	160,0	171,0	236	2,5	2,5	9,40
51,40	2400	3000		154	160,0	171,0	236	2,5	2,5	9,40
76,53	2000	2400		158	166,0	182,0	282	3,0	3,0	23,0
76,53	2000	2400		158	166,0	182,0	282	3,0	3,0	23,0
25,35	2700	3200	150	159	165,0	173,0	213	2,0	1,5	4,85
58,08	2200	2800		164	170,0	184,0	256	2,5	2,5	12,0
58,08	2200	2800		164	170,0	184,0	256	2,5	2,5	12,0
86,83	1800	2200		168	185,0	195,0	302	3,0	3,0	27,0
86,83	1800	2200		168	185,0	195,0	302	3,0	3,0	27,0



Double row spherical roller bearing
PLC 58-11; PLC 58-9-1

Double row spherical roller bearing
PLC 010-3

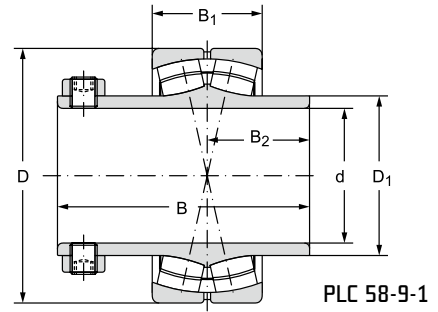
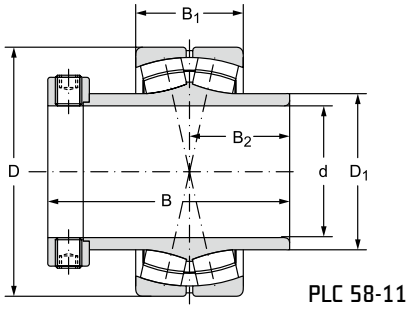

Main dimensions						Basic load rating	
d	D	D ₁	B ₁ min	B ₂ min	B	dynamic C _r	static C _{or}
mm						kN	
74,6	120	88,34	31,0	31,80	92,0	196	255
76,2	130	88,71	31,0	31,75	92,2	196	255
140,0	215	225,00	38,1	10,71	42,9	116	139

12.12.4

Single row ball bearing PLC 010-3

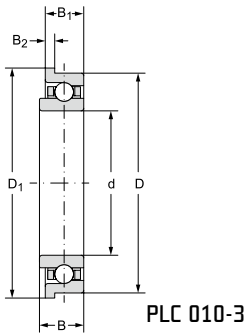

Fatigue load limit	Weight	Bearing designation
P_u	~	
kN	kg	
31,10	3,00	PLC 58-11
30,81	3,10	PLC 58-9-1
4,74	5,30	PLC 010-3



Double row spherical roller bearings PLC 59-10; PLC 511-14

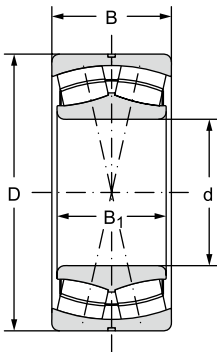

PLC 59-10

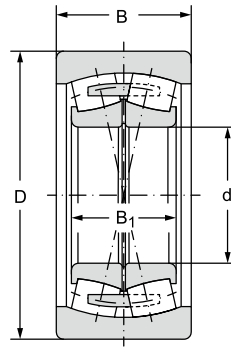

PLC 511-14

12.12.5

Main dimensions				Basic load rating	
d	D	B ₁	B	Dynamic C _r	Static C _{or}
mm				kN	
110	180,00	69,0	82,0	501	839
110	288,92	80,0	115,9	786	978

1) Bearing with extended outer race for tilting angles up to 6°
 2) Support pulley

Fatigue load limit	Weight	Bearing designation	Note
P_u	~		
kN	kg		
91,52	7,70	PLC 59-10	1)
96,95	40,0	PLC 511-14	2)



Double row spherical roller bearing PLC 58-2

Single row ball bearing KL 761

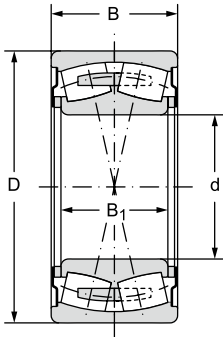

PLC 58-2

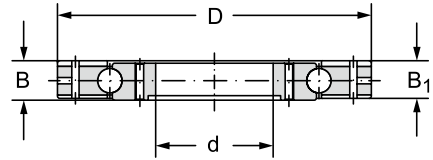

KL 761

12.12.6

Main dimensions				Basic load rating	
d	D	B ₁	B	Dynamic C _r	Static C _{or}
mm				kN	
65	158,8	48,0	70,0	212	250
559	761,0	36,5	38,2	232	425

1) Single row ball bearing for debarking machines in woodworking industry

Fatigue load limit	Weight	Bearing designation	Note
P_u	~		
kN	kg		
29,48	7,36	PLC 58-2	
7,52	51,3	KL 761	1)



Double row spherical roller bearings PLC 58-6; PLC 59-5; PLC 512-5

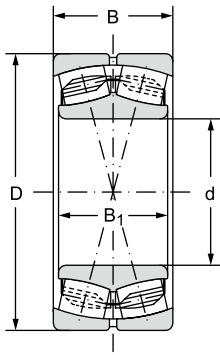

PLC 58-6

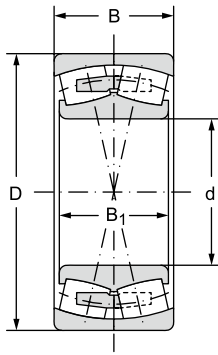

PLC 59-5

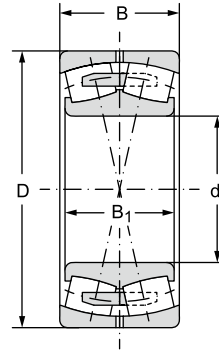

PLC 512-5

12.12.7

Main dimensions				Basic load rating	
d	D	B ₁	B	Dynamic C _r	Static C _{or}
mm				kN	
100	150	62	50	310	550
100	180	69	82	480	710
440	720	226	270	4300	9000

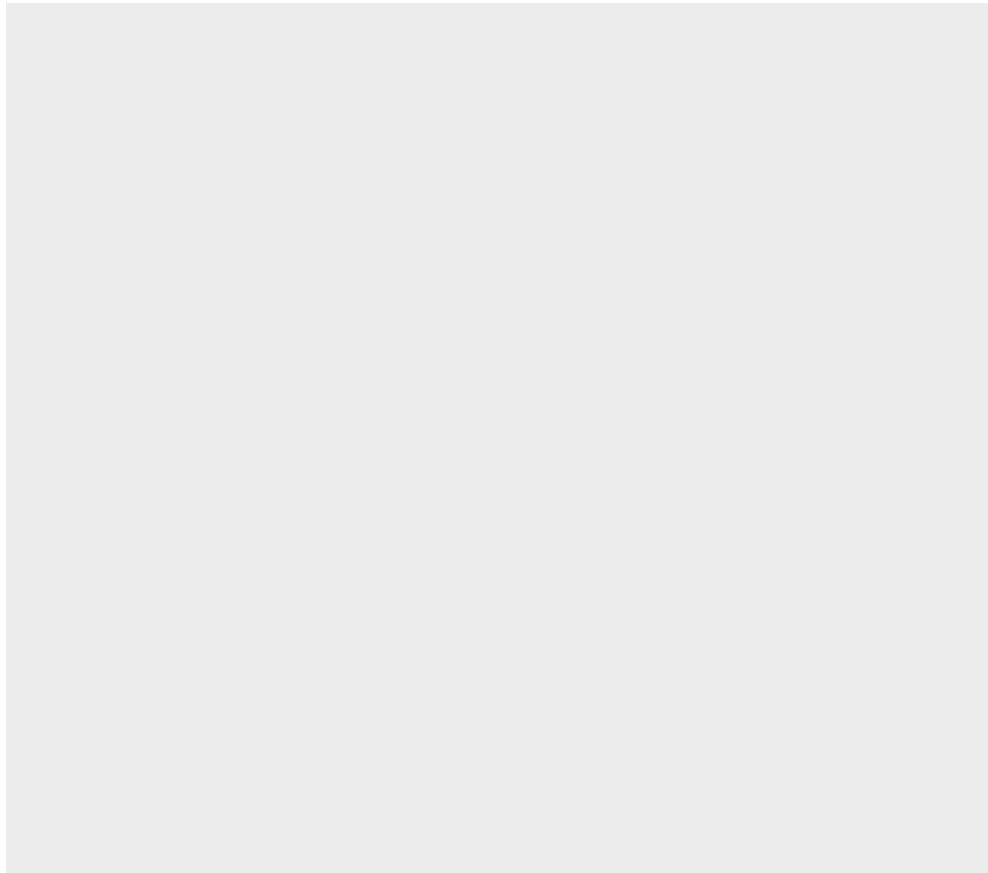

- 1) Double row spherical-roller bearing with increased tipping angle up to 7° for location of concrete agitator transmission.
- 2) Double row spherical-roller bearing with increased tipping angle up to 7° for location of concrete agitator transmission.
- 3) Double row spherical-roller bearing with increased tipping angle up to 7°.

Fatigue load limit	Weight	Bearing designation	Note
P_u	~		
kN	kg		
62,73	3,70	PLC 58-6	1)
78,27	10,30	PLC 59-5	2)
647,74	389	PLC 512-5	3)

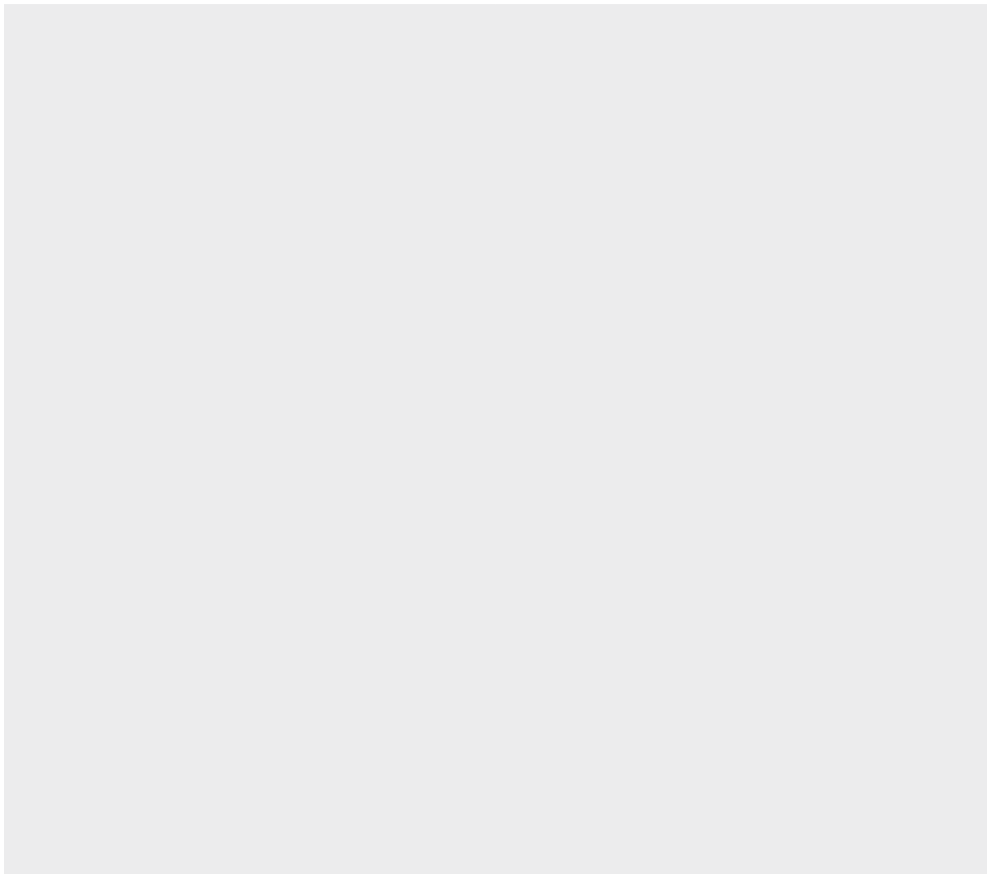

Double row spherical roller bearings PLC 59-7; PLC 510-9; PLC 510-20

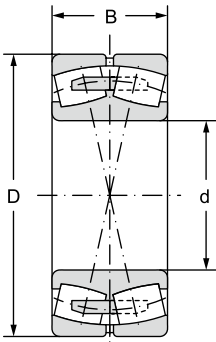

PLC 59-7

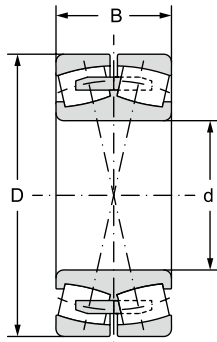

PLC 510-9

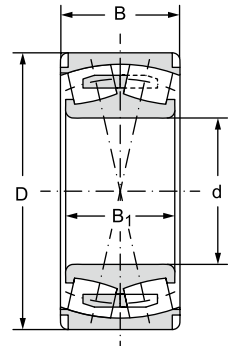

PLC 510-20

12.12.8

Main dimensions				Basic load rating	
d	D	B ₁	B	Dynamic C _r	Static C _{or}
mm				kN	
111,6	215	90	76	564	803
130,0	220	73		570	1080
130,0	225	80		570	1080

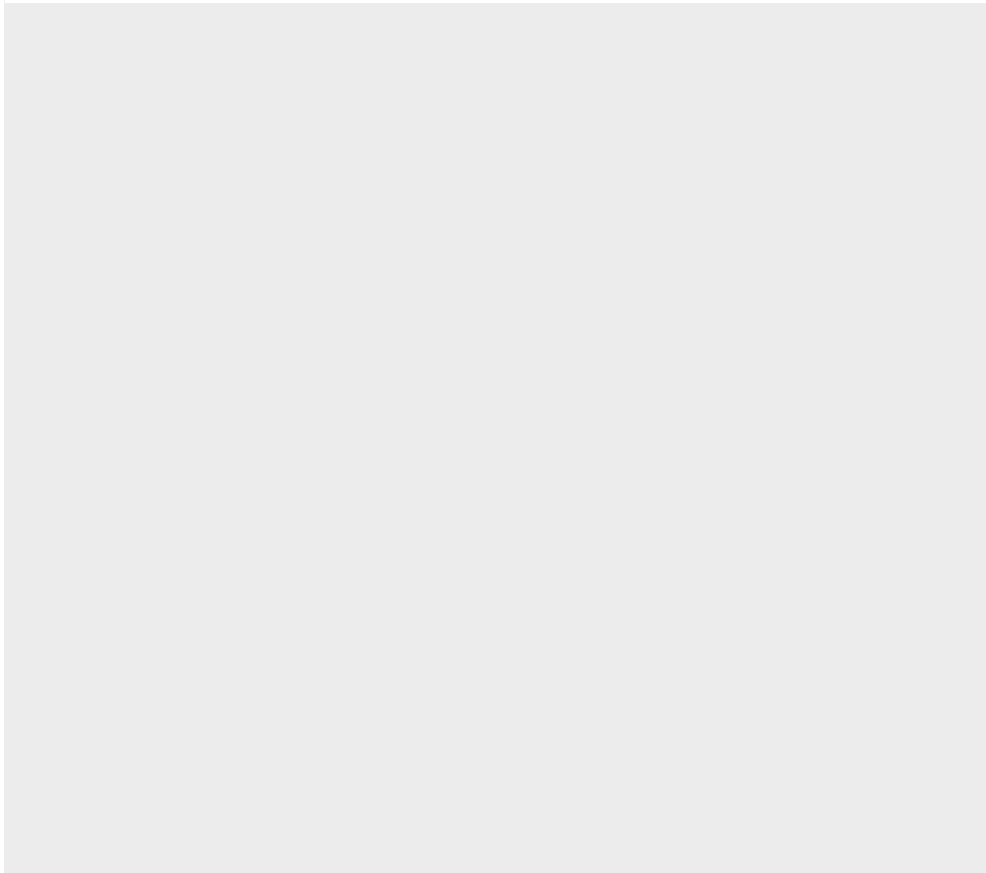

1) Double row spherical roller bearing according to UIC dimensional plan for location of rail vehicle axles with 130mm journal.

Fatigue load limit	Weight	Bearing designation	Note
P_u	~		
kN	kg		
84,5	14,4	PLC 510-20	
111	12,2	PLC 59-7	1)
111	12,2	PLC 510-9	



Special double row ball bearings PLC 77-1; PLC 14-28; PLC 14-29

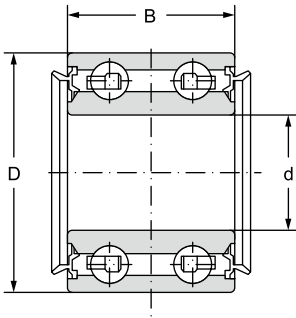

PLC 77-1

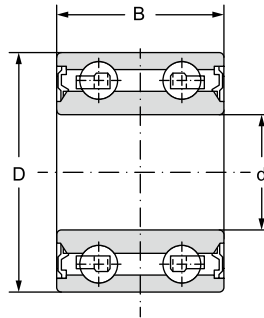

PLC 14-28

Main dimensions			Basic load rating		Fatigue load limit
d	D	B	dynamic C_f	static C_{or}	P_u
mm			kN		kN
25	52	43,8	24,3	17,7	0,80
25	52	37,0	24,3	17,7	0,80
36	62	16,0	24,1	27,1	1,23

12.12.9

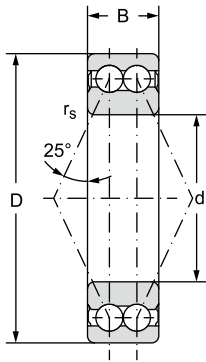

PLC 14-29

Limiting speed for lubrication with		Weight	Bearing designation
grease	oil		
min ⁻¹		kg	
5250	-	0,301	PLC 77-1
5250	-	0,301	PLC 14-28
4410	-	0,192	PLC 14-29



Single row ball bearings PLC 03-29; PLC 03-33; PLC 03-79

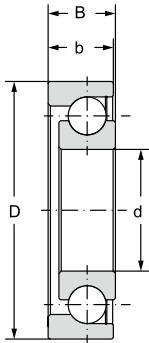

PLC 03-29

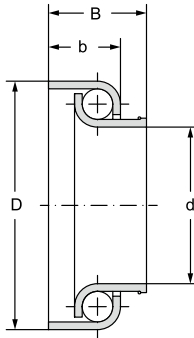

PLC 03-33

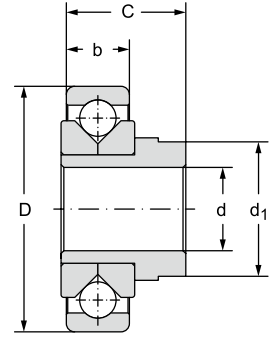

PLC 03-79

12.12.10

Main dimensions			Basic load rating		Fatigue load limit
d	D	B	dynamic C_f	static C_{or}	P_u
mm			kN		kN
17,0	35,0	9,0	8,20	5,30	0,24
22,2	36,9	16,5	5,11	6,31	0,29
10,4	35,0	10,0	4,82	1,36	0,06

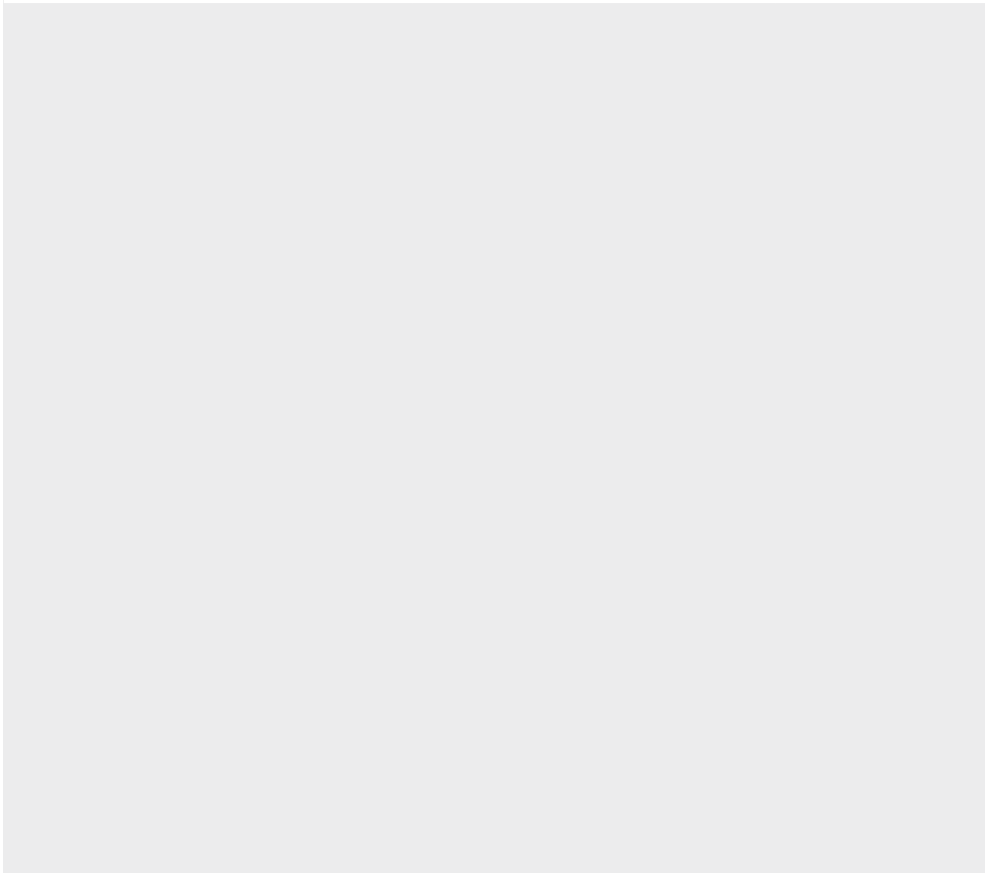

1) track bar location

Limiting speed for lubrication with		Bearing designation	Weight
grease	oil		
min ⁻¹			~ kg
18000	21000	PLC 03-29	0,033
1) 12600	1) 17000	PLC 03-33	0,034
		PLC 03-79	0,069

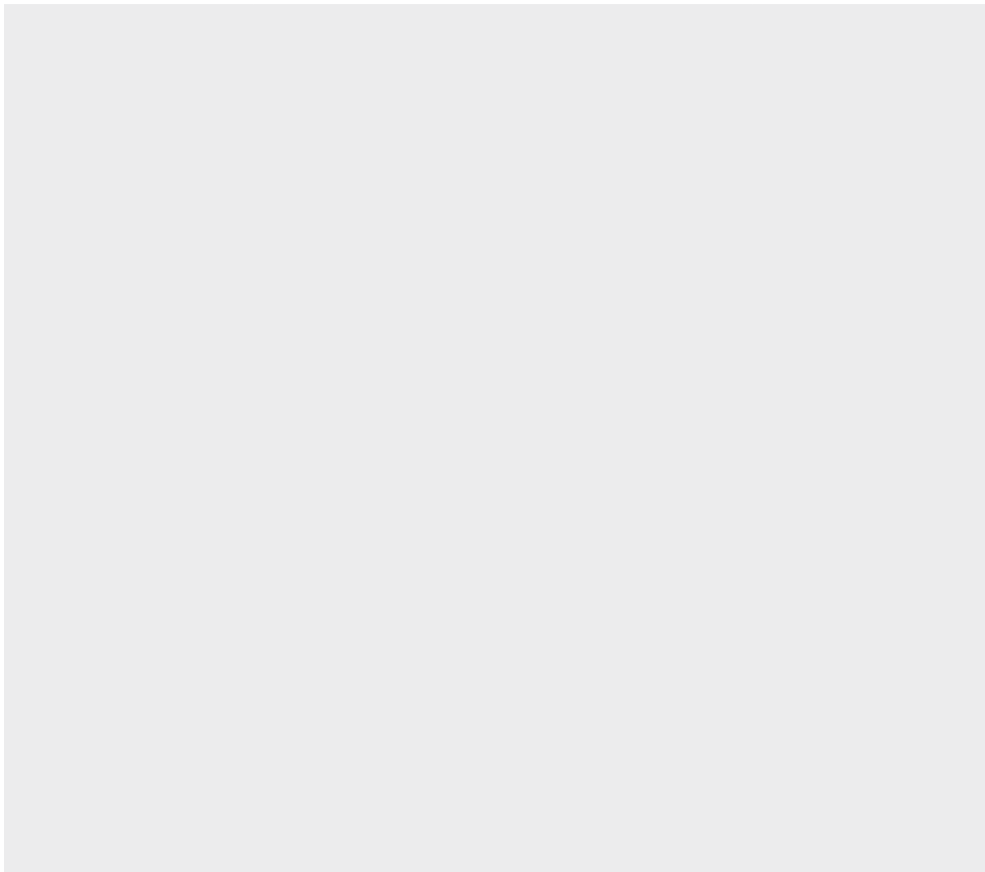

Special thrust ball bearings 511Z30; PLC 23-4; PLC 23-5; 511Z35; PLC 24-2;
 PLC 24-4; PLC 24-5; PLC 24-6; PLC 23-7

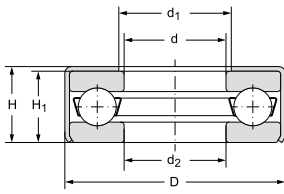

511Z30
511Z35

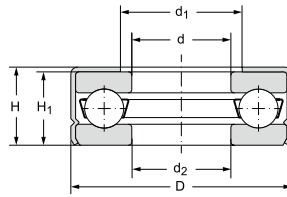

PLC 23-4

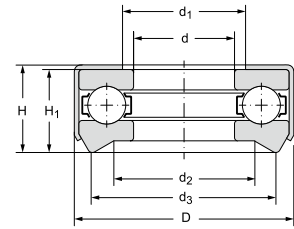

PLC 23-5

12.12.11	Main dimensions			Basic load rating		Fatigue load limit
	d	D	H	dynamic C_a	static C_{oa}	P_u
	mm			kN		kN
30,0	49,2	12,0	18,8	31,6	1,44	
	49,2	12,0	17,4	28,2	1,28	
	49,2	13,6	17,4	28,2	1,28	
35,0	53,6	12,8	20,0	38,3	1,74	
	53,6	15,5	20,0	38,3	1,74	
17,0	35,0	12,3	9,6	15,5	0,70	
45,2	65,0	10,8	27,8	57,5	2,61	
40,1	59,9	10,8	26,9	51,2	2,33	
55,2	78,0	11,6	34,8	78,4	3,56	

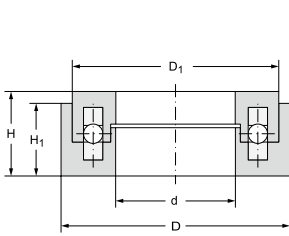

PLC 23-7

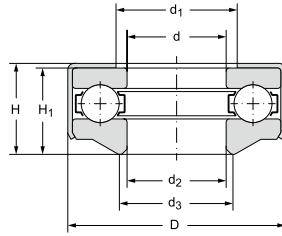

PLC 24-2

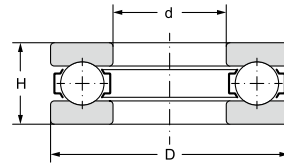

24-4

1) The bearing is designed for oscillatory movement or low revolution frequencies.

Limiting speed for lubrication with		Weight	Bearing designation	Abutment and fillet dimensions				
grease	oil			\sim	d_1	d_2	d_3	H_1
min^{-1}		kg		mm				
4200	-	0,086	511Z30	36,0	30,2	-	11,0	0,6
4200	-	0,083	PLC 23-4	36,0	30,8	-	11,0	0,6
4200	-	0,085	PLC 23-5	36,0	30,8	40	12,5	0,6
4000	-	0,093	511Z35	38,0	37,0	-	12,0	0,6
3500	-	0,111	PLC 24-2	38,0	37,0	40	14,7	0,6
1)		0,029	PLC 23-7	17,2	32,4	-	10,4	0,5
3800	5000	0,100	PLC 24-4	-	-	-	-	-
3800	5000	0,090	PLC 24-5	-	-	-	-	-
3200	4200	0,150	PLC 25-6	-	-	-	-	-



Special double row angular contact ball bearings PLC 15-2; PLC 14-26;
 PLC 14-25; PLC 14-24; PLC 15-22; PLC 15-12

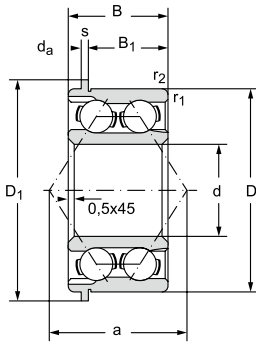

PLC 15-2

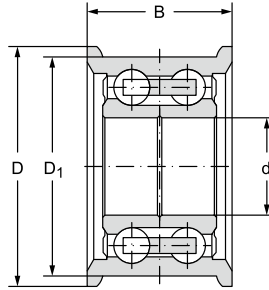

PLC 14-26

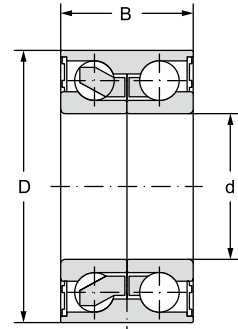

PLC 14-25, PLC 14-24, PLC 15-22

12.12.12

Main dimensions			Basic load rating		Fatigue load limit	Limiting speed for lubrication with	
d	D	H	dynamic C_r	static C_{or}	P_u	grease	oil
mm			kN		kN	min ⁻¹	
25	65,5	25,4	30,4	26,6	1,21	7100	8400
	55,0	20,0	19,2	15,5	0,70	8500	10000
30	60,0	37,0	36,9	30,4	1,38	7000	8300
34	64,0	37,0	36,9	31,0	1,41	6300	7500
37	72,0	37,0	43,8	39,8	1,81	5000	6000
35	68,0	37,0	39,8	38,3	1,74	6500	-

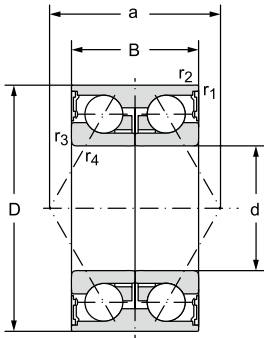

PLC 15-12

- 1) Bearing with pressed cage guided on balls.
The bearing is designed for shafts in motor vehicle transmissions.
- 2) Bearing with polyamide cage guided on balls; special sealing ring on both sides filled with lubricant.
The bearing is designed for applications in automotive industry (wheel bearing).

Weight	Bearing designation	Abutment and fillet dimensions						
		d	D ₁	B ₁	s	r _{1,2}	r _{3,4}	a
~		mm						
kg		mm						
0,466	PLC 15-21)	25	74	16,5	4,4	1,1	-	40,0
0,280	PLC 14-26	25	62	28,0	-	-	1,0	26,8
0,450	PLC 14-25	30	-	-	-	2,5	0,5	50,5
0,320	PLC 14-24	34	-	-	-	2,8	0,3	53,3
0,550	PLC 15-22	37	-	-	-	2,8	0,3	57,0
0,534	PLC 15-122)	35	-	-	-	2,5	0,3	50,5







12.13 BEARING HOUSINGS AND ACCESSORIES

- CLAMP-TYPE BEARINGS AND HUBS
- BEARING HOUSINGS FOR STANDARD BEARINGS
- ROLLING BEARING ACCESSORIES

CLAMP-TYPE BEARINGS AND HUBS

Clamp-type bearings are single row ball bearings with seals on both sides. The outer ring has a spherical surface, which allows tilting of the surfaces in housings with the same spherical modification. This makes it possible to compensate for any misalignment. The inner bearing ring is wider than the outer ring and is attached to the shaft:

- using an eccentric clamping ring, structurally designed under the marking UA,
- by screws, structurally designed under the marking UC.

Bearings are pre-packed with grease and maintenance-free for the lifetime of the bearing. The housing design also permits re-lubrication via a lubricating nipple. Bearings are suitable for loading short shafts and for loadings with low thermal expansion, which compensate axial clearance in bearings or flexibility of the structure, on which the bearings are fastened.

The hub material is made of cast iron or steel plating and can be divided from a structural viewpoint into upright housings – marked SG, SE or flanged – marked FG, FM, FB, and FE. The hub has a round bore that contains the bearings; together, they form a unit, which provides an efficient solution with a simple loading design. They are used primarily in agricultural machinery, transportation equipment, food machinery, and similar equipment.

Clamp-type bearing design

Clamp-type bearings are available in several versions, which are designed to meet various technical requirements. All clamp-type bearings have outer rings with a spherical surface and are equipped with seals that provide optimum protection against entry of contaminants, particularly in dirty operating environments.

UA design

The UA clamp-type bearing has an extended inner ring on both sides. The design is similar to the UC design, but it differs in its shaft fastening method. The inner bearing ring is attached to the shaft by an eccentric clamping ring, which is additionally secured to the shaft by screws. The UA design enables quick, efficient, and easy installation of bearings onto the shaft. Clamp-type bearings in this design are suitable for single direction rotation applications.





UC design

The UA clamp-type bearing has an extended inner ring on both sides, which enables the use of more effective packing. These bearing loadings have a larger internal space, which serves as a grease reservoir. This provides for extended service intervals and supports their use in demanding conditions. The inner ring is fastened onto the shaft using two screws, just like the US series. UC version bearings can be re-lubricated via lubricating nozzles on the outer ring.

UE design

Clamp-type UE bearings have an extended inner ring on one side and are fastened to the shaft by an eccentric clamping ring. These bearings are suitable in applications that have the same direction of rotation. Bearings in this version cannot be re-lubricated.

UD design

UD clamp-type bearings have identical inner ring and outer ring widths.

US version

US clamp-type bearings have an extended inner ring on one side. These bearings are suitable even for standard applications with alternating directions of rotation. Bearings in this version cannot be re-lubricated. The inner ring is fastened to the shaft by two screws that are set at 120° to each other. This locking method provides quick, efficient, and easy installation of the bearing onto the shaft.

Main dimensions

The main dimensions of clamp-type bearings meet standard ISO 2264, standard ISO 3228 for bearing housings, and standard ISO 3145 for eccentric clamping rings.

Labelling

Labelling of clamp-type bearings, respective clamping elements, and complete units is provided in the tables of the publication.

Cage

Bearings have unlabelled cages made from pressed steel plating. Bearings, in special cases, can be supplied with a different cage designs. Please consult the distributor for the availability of bearings with different cages.

Precision

Clamp-type bearings are standardly produced at a normal degree of precision P0. Higher degrees of precision P6 and P5 are available upon request. The distributor must be consulted.

Bearings have a uniform bore diameter tolerance of H6. This tolerance ensures the shaft tolerance, during machining, lies within the field h for each sliding loading. Tolerances of h8 to h11 are generally sufficient for the production of shafts. Higher loads and speeds require of higher tolerances – h6, h7.

Radial clearance

Commonly manufactured clamp-type bearings have a normal radial clearance, which is not marked and its size and span are identical to single row ball bearings of identical dimensions. Any delivery of bearings with different radial clearances must be negotiated in advance with the supplier.

Rotation limiting speed

This parameter is largely dependent on the shaft fitting and the shaft diameter tolerance. The specified relationship is provided in the appropriate tables.

Minimal load

Bearings require a minimal load under all operating conditions. The minimal load of clamp-type bearings is 1% of the dynamic load capacity of the bearing.

BEARING HOUSINGS FOR STANDARD BEARINGS

ZKL bearing housings are designated for the standard product line of inclined double row ball bearings and spherical roller bearings. ZKL bearing housings provide ideal bearing loadings for the lifetime of the bearing and decrease the maintenance costs. ZKL bearing housings are suitable for both oil and grease lubrication. We can find applications of ZKL bearing housings for standard bearings, in particular, in various machines, equipment, and facilities.

Bearing housing material

Bearing housings are standardly produced from grey cast iron; in special cases, bearing housings can also be made from ductile iron or cast steel. ZKL Technical and Consultation Services can be consulted for advice on the selection of the most suitable material.

All external bearing housing surfaces, which are not machined, are treated with a universal coating that protects the bearing housing against corrosion. Functional machined surfaces are treated with an anti-corrosion coating, which can easily be removed during installation.

Bearing loadings

Bearing housings are exclusively manufactured for free axial loadings, when the bearing does not transfer axial loads and enables axial sliding of the bearing in the bearing housing. This loading is suitable for compensating for the thermal expansion of shafts. In the case of axial guided loadings, the same bearing housing is used together with axial guide rings. If the bearing is to carry bilateral axial loads, then axial guide rings must be used on both sides.



Seals

Bearing housings may be sealed depending on the operating conditions and method of lubrication of the contact seal, non-contact seal, or combination of non-contact and contact seal. Seals should be selected in consultation with Technical and Consultation Services, who determine the optimal solution for bearing housing seals under the given operating conditions.

Upright bearing housings

Split and non-split upright bearing housings are designated exclusively for inclined double row ball bearings and double row spherical roller bearings. The upper section of the split housing is centred during installation using centring pins, which ensure proper seating of both housing sections. The upper sections of housings must not be confused. Upright bearing housings are standardly equipped with two or four bores for bolts.

Flanged bearing housings

Flanged housings are also designated for self-aligning double row ball bearings and double row spherical roller bearings. They are produced in two versions, depending on the size. The smaller and less burdened housings have a triangular shape with three bolt bores. The larger and more burdened have a square shape with four bolt bores. Flanged bearing housings are designed for grease lubrication and are most often sealed using felt sealing rings.

ROLLING BEARING ACCESSORIES

Accessories include machine components that serve to fasten roller bearings to a shaft or into a hole of the element.

Adapter sleeves

Adapter sleeves are used for fastening double row self-aligning ball bearings and double row spherical roller bearings with tapered hole (K) onto cylindrical shafts. Adapter sleeves are made of steel with a tensile strength of 400 to 600 MPa. The main dimensions of adapter sleeves are specified in the tables provided and they meet standard ISO 2982-1.

Labelling of adapter sleeves, together with nuts and locking elements is specified in the tables provided. Information on matching sleeves with individual bearings with a tapered bore is specified in the relevant section, dedicated to double row self-aligning bearings and double row spherical roller bearings. Connection dimensions for bearings with adapter sleeves are provided in table 12.13.1.

Table 12.13.1

Nominal diameter		Type of adapter sleeve															
		H2		H3			H23			H30		H31		H32			
		Dimensional group of bearings															
d	d ₀	O2		22		O3	32		23	30		31		22	32		
		d _b min	a _a min	d _b min	a _a min		d _b min	a _a min		d _b min	a _a min	d _b min	a _a min	d _b min	a _a min	d _b min	a _a min
mm																	
20	17	23	5	23	5	8	24	-	5	-	-	-	-	-	-	-	-
25	20	28	5	28	5	6	30	-	5	-	-	-	-	-	-	-	-
30	25	33	5	33	5	6	35	-	5	-	-	-	-	-	-	-	-
35	30	38	5	39	5	8	40	-	5	-	-	-	-	-	-	-	-
40	35	43	5	44	5	5	45	-	5	-	-	-	-	-	-	-	-
45	40	48	5	50	8	5	50	-	5	-	-	-	-	-	-	-	-
50	45	53	5	55	10	5	56	-	5	-	-	-	-	-	-	-	-
55	50	60	6	60	19	6	61	-	6	-	-	-	-	-	-	-	-
60	55	64	5	65	8	5	66	-	5	-	-	-	-	-	-	-	-
65	60	70	5	70	8	5	72	-	5	-	-	-	-	-	-	-	-
70	60	75	5	75	10	5	76	-	5	-	-	-	-	-	-	-	-
75	65	80	5	80	12	5	82	-	5	-	-	-	-	-	-	-	-
80	70	85	5	85	12	5	88	-	5	-	-	-	-	-	-	-	-
85	75	90	6	91	12	6	94	-	6	-	-	-	-	-	-	-	-
90	80	95	6	96	10	6	100	18	6	-	-	-	-	-	-	-	-
100	90	106	7	108	8	7	110	19	7	-	-	-	-	-	-	-	-
110	100	116	7	118	6	9	121	17	7	-	-	117	7	-	-	-	-
120	110	-	-	-	-	-	131	17	7	127	7	128	7	11	-	-	-
130	115	-	-	-	-	-	142	21	8	137	8	138	8	8	-	-	-
140	125	-	-	-	-	-	152	22	8	147	8	149	8	8	-	-	-
150	135	-	-	-	-	-	163	20	8	158	8	160	8	15	-	-	-
160	140	-	-	-	-	-	174	18	8	168	8	170	8	14	-	-	-
170	150	-	-	-	-	-	185	18	8	179	8	180	8	10	-	-	-
180	160	-	-	-	-	-	195	22	8	189	8	191	8	18	-	-	-
190	170	-	-	-	-	-	206	21	9	199	9	202	9	21	-	-	-
200	180	-	-	-	-	-	216	20	10	210	10	212	10	24	-	-	-
220	200	-	-	-	-	-	236	11	10	231	12	233	10	22	-	-	-
240	220						257	6	11	251	11	254	11	19			
260	240						278	2	11	171	13	276	11	25			
280	260						299	11	12	292	12	296	12	28			
300	280									313	12	318	12	32	321	12	
320	300									334	13	338	13	39	343	13	
340	320									355	14	360	14	-	-	-	
360	340									375	14	380	14	-	-	-	

Connection dimensions $d_{a \min}$, $D_{a \max}$ and $r_{a \max}$ are specified in dimension tables of double row self-aligning ball bearings and double row spherical roller bearings



Withdrawal sleeves

Withdrawal sleeves are used for fastening double row spherical roller bearings with a tapered bore (K) onto cylindrical shafts. Sleeves are made of steel with a tensile strength of 400 to 600 MPa.

Main dimensions of withdrawal sleeves meet standard ISO 2982-2.

Designations of withdrawal sleeves and respective withdrawal nuts, which must be ordered separately, are listed in the tables provided.

Information on assignments of withdrawal sleeves to individual double row spherical roller bearings with a tapered bore are listed in the respective sections, dedicated to such bearings. Connecting dimensions for bearings with withdrawal sleeves ($d_{a \text{ min}}$, $D_{a \text{ max}}$, $r_{a \text{ max}}$) are identical to bearings without withdrawal sleeves and are listed in the respective tables of the publication.

Adapter and withdrawal sleeves ring nuts

Adapter and withdrawal sleeve nuts are used for fastening internal bearing rings onto adapter sleeves or directly onto the journal. Withdrawal nuts are used for removing double row spherical roller bearings with a tapered bore that are fastened by means of a withdrawal sleeve. Rings nuts are made of steel with a minimal tensile strength of 410 MPa.

The main dimensions of adapter and withdrawal nuts are specified in the tables provided and they meet standard ISO 2982-2.

Adapter nuts are made in standard design (type KM) and specific design (type KMA) and are listed in the table section of the publication. Proceed according to table 12.13.2 when determining the front axial runout.

Table 12.13.2

Designation of nut size		Limit axial runout values of functional face	
over	up to	KM	KMA
		mm	
	10	0,04	0,025
10	20	0,05	0,03
20	25	0,05	0,03
25	30	0,06	0,04
30	40	0,06	0,05

Lock washers

The washers are used for fastening adapter ring nuts. They are made from steel with a minimal tensile strength of 274 MPa. The main dimensions of washers are specified in the tables provided and they meet standard ISO 2982.

Snap rings for bearings with a groove on the outer ring

Snap rings are used for simple axial fastening of bearings with groove on outer race (N) in hubs. Snap rings are made of spring steel. Main dimensions of snap rings meet standard ISO 464.

Snap rings are labelled with a number that expresses the outer bearing diameter D and a number that expresses the minimal width of the snap ring f , e.g. ring 52/1.02.

Trade labels are also used in practise to designate the type of ring R and the outer bearing diameter in mm, e.g. R52.

The tables list snap rings for N-style single row ball bearings, types 60, 62, 63, and 64.

Snap rings are, in rare circumstances, also used for bearings of different design groups. Their delivery must be negotiated with the supplier in advance. Snap rings are supplied individually.



Adapter sleeves d = 20 to 150 mm

d = 20 to 65 mm

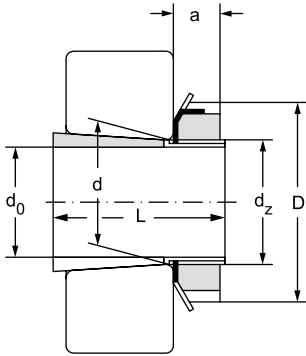

Main dimensions					
d ₀	d	d _z	D	L	a
mm					
20	25	M25x1,5	38	26	8
	25	M25x1,5	38	29	8
	25	M25x1,5	38	29	10,5
	25	M25x1,5	38	35	8
25	30	M30x1,5	45	27	8
	30	M30x1,5	45	31	8
	30	M30x1,5	46	31	10,5
	30	M30x1,5	45	38	8
30	35	M35x1,5	52	29	9
	35	M35x1,5	52	35	9
	35	M35x1,5	52	35	11,5
	35	M35x1,5	52	35	11,5
	35	M35x1,5	52	43	9
35	40	M40x1,5	58	31	10
	40	M40x1,5	58	36	10
	40	M40x1,5	59	36	13
	40	M40x1,5	58	46	10
	40	M40x1,5	58	46	13
40	45	M45x1,5	65	33	11
	45	M45x1,5	65	39	11
	45	M45x1,5	65	39	13
	45	M45x1,5	65	50	11
45	50	M50x1,5	70	35	12
	50	M50x1,5	70	42	12
	50	M50x1,5	70	42	14
	50	M50x1,5	70	55	12
50	55	M55x2	75	37	12
	55	M55x2	75	45	12
	55	M55x2	75	45	14
	55	M55x2	75	59	12
55	60	M60x2	80	38	13
	60	M60x2	80	47	13
	60	M60x2	80	47	14
	60	M60x2	80	62	13

Sleeve designation incl. nut and locking	Appropriate components		Weight
	nut	locking	kg
H205	KM5	MB5	0,07
H305	KM5	MB5	0,075
H305E	KMFE5	-	0,076
H2305	KM5	MB5	0,087
H206	KM6	MB6	0,099
H306	KM6	MB6	0,109
H306E	KMFE6	-	0,11
H2306	KM6	MB6	0,126
H207	KM7	MB7	0,125
H307	KM7	MB7	0,142
H307E	KMFE7	-	0,15
H307EL	KMFE7L	-	0,16
H2307	KM7	MB7	0,165
H208	KM8	MB8	0,174
H308	KM8	MB8	0,189
H308E	KMFE8	-	0,19
H2308	KM8	MB8	0,224
H2308E	KMFE8	-	0,24
H209	KM9	MB9	0,227
H309	KM9	MB9	0,248
H309E	KMFE9	-	0,24
H2309	KM9	MB9	0,28
H210	KM10	MB10	0,274
H310	KM10	MB10	0,303
H310E	KMFE10	-	0,3
H2310	KM10	MB10	0,362
H211	KM11	MB11	0,308
H311	KM11	MB11	0,345
H311E	KMFE11	-	0,34
H2311	KM11	MB11	0,42
H212	KM12	MB12	0,346
H312	KM12	MB12	0,394
H312E	KMFE12	-	0,4
H2312	KM12	MB12	0,481



Adapter sleeves

d = 70 to 135 mm

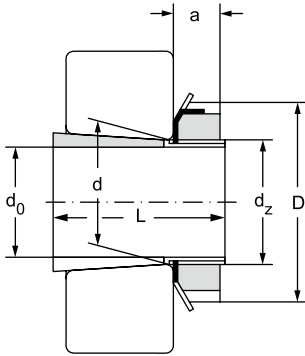

12.13.1

Main dimensions					
d ₀	d	d _z	D	L	a
mm					
60	65	M65x2	85	40	14
	65	M65x2	85	50	14
	65	M65x2	85	50	15
	65	M65x2	85	65	14
	65	M65x2	85	65	15
65	75	M75x2	98	43	15
	75	M75x2	98	55	15
	75	M75x2	98	55	16
	75	M75x2	98	73	15
70	80	M80x2	105	46	17
	80	M80x2	105	59	17
	80	M80x2	105	59	18
	80	M80x2	105	78	17
75	85	M85x2	110	50	18
	85	M85x2	110	63	18
	85	M85x2	110	63	19
	85	M85x2	110	82	18
80	90	M90x2	120	62	18
	90	M90x2	120	65	18
	90	M90x2	120	65	19
	90	M90x2	120	73	19
	90	M90x2	120	86	18
85	95	M95x2	125	55	19
	95	M95x2	125	68	19
	95	M95x2	125	68	20
	95	M95x2	125	90	19
	95	M95x2	125	90	20
90	100	M100x2	130	58	20
	100	M100x2	130	71	20
	100	M100x2	130	71	21
	100	M100x2	130	76	20
	100	M100x2	130	76	21
	100	M100x2	130	97	20
	100	M100x2	130	97	21

Sleeve designation incl. nut and locking	Appropriate components		Weight
	nut	locking	kg
H213	KM13	MB13	0,401
H313	KM13	MB13	0,458
H313E	KMFE13	-	0,43
H2313	KM13	MB13	0,557
H2313E	KMFE13	-	0,53
H215	KM15	MB15	0,707
H315	KM15	MB15	0,831
H315E	KMFE15	-	0,82
H2315	KM15	MB15	1,05
H216	KM16	MB16	0,882
H316	KM16	MB16	1,03
H316E	KMFE16	-	1
H2316	KM16	MB16	1,28
H217	KM17	MB17	1,02
H317	KM17	MB17	1,18
H317E	KMFE17	-	1,15
H2317	KM17	MB17	1,45
H218	KM18	MB18	1,19
H318	KM18	MB18	1,37
H318E	KMFE18	-	1,45
H2318E/L73	KMFE18	-	1,5
H2318	KM18	MB18	1,69
H219	KM19	MB19	1,37
H319	KM19	MB19	1,56
H319E	KMFE19	-	1,45
H2319	KM19	MB19	1,92
H2319EL	KMFE19	-	1,85
H220	KM20	MB20	1,49
H320	KM20	MB20	1,69
H320E	KMFE20	-	1,7
H3120	KM20	MB20	1,8
H3120E	KMFE20	-	2
H2320	KM20	MB20	2,15
H2320E	KMFE20	-	2



Adapter sleeves

d = 140 to 180 mm

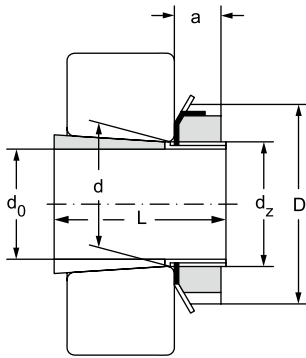

Main dimensions					
d_0	d	d_z	D	L	a
mm					
100	110	M110x2	145	81	21
	110	M110x2	145	81	21,5
	110	M110x2	145	63	21
	110	M110x2	145	77	21
	110	M110x2	145	77	21,5
	110	M110x2	145	105	21
	110	M110x2	145	105	21,5
110	120	M120x2	145	72	22
	120	M120x2	145	88	22
	120	M120x2	155	112	26
	120	M120x2	155	72	26
	120	M120x2	155	88	22
	120	M120x2	155	112	22
	120	M120x2	155	112	26
	120	M120x2	155	112	26
115	130	M130x2	155	80	23
	130	M130x2	155	92	23
	130	M130x2	165	121	23
	130	M130x2	165	80	28
	130	M130x2	165	92	23
	130	M130x2	165	121	23
125	140	M140x2	165	82	24
	140	M140x2	180	97	24
	140	M140x2	180	82	28
	140	M140x2	180	97	24
	140	M140x2	180	131	24
135	150	M150x2	180	87	26
	150	M150x2	195	111	26
	150	M150x2	195	139	26
	150	M150x2	195	87	30
	150	M150x2	195	111	26
	150	M150x2	195	111	30
	150	M150x2	195	139	26

Sleeve designation incl. nut and locking	Appropriate components		Weight
	nut	locking	kg
H3122	KM22	MB22	2,25
H3122E	KMFE22	-	2,15
H222	KM22	MB22	1,93
H322	KM22	MB22	2,18
H322E	KMFE22	-	2,1
H2322	KM22	MB22	2,74
H2322E	KMFE22	-	2,75
H3024	KML24	MBL24	1,93
H3124L	KML24	MBL24	2,5
H2324L			
H3024E	KMFE24	-	1,85
H3124	KM24	MB24	2,64
H2324	KM24	MB24	3,19
H2324EH	KMFE24H	-	3,1
H2324EH	KMFE24H	-	3,1
H3026	KML26	MBL26	2,85
H3126L	KML26	MBL26	3,65
H2326L	KML26	MBL26	4,15
H3026E	KMFE26	-	2,9
H3126	KM26	MB26	3,66
H2326	KM26	MB26	4,6
H3028	KML28	MBL28	3,16
H3128L	KML28	MBL28	4,1
H3028E	KMFE28	-	3,05
H3128	KM28	MB28	4,34
H2328	KM28	MB28	5,55
H3030	KML30	MBL30	3,89
H3130L	KML30	MBL30	4,7
H2330L	KML30	MBL30	5,85
H3030E	KMFE30	-	3,75
H3130	KM30	MB30	5,52
H3130E	KMFE30	-	4,7
H2330	KM30	MB30	6,63



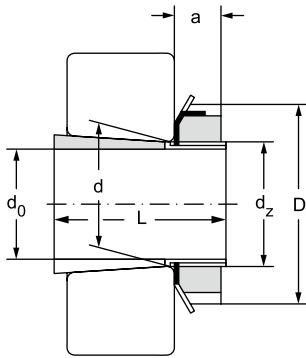

12.13.1

Main dimensions					
d_0	d	d_z	D	L	a
mm					
140	160	M160x3	190	93	28
	160	M160x3	190	93	28
	160	M160x3	190	147	28
	160	M160x3	210	147	28
	160	M160x3	210	119	28
	160	M160x3	210	119	32
	160	M160x3	210	147	28
150	170	M170x3	200	101	29
	170	M170x3	200	101	29
	170	M170x3	220	101	33
	170	M170x3	220	122	29
	170	M170x3	220	122	33
	170	M170x3	220	154	29
160	180	M180x3	210	87	29,5
	180	M180x3	210	109	30
	180	M180x3	230	131	30
	180	M180x3	230	109	34
	180	M180x3	230	131	30
	180	M180x3	230	161	30
170	190	M190x3	220	89	30,5
	190	M190x3	220	112	31
	190	M190x3	240	141	31
	190	M190x3	240	169	31
180	200	M200x3	240	98	31,5
	200	M200x3	240	120	32
	200	M200x3	250	176	32
	200	M200x3	250	150	32
	200	M200x3	250	176	32
200	220	Tr220x4	260	96	30
	220	Tr220x4	260	126	30
	220	Tr220x4	260	161	30
	220	Tr220x4	280	161	35
	220	Tr220x4	280	186	35

Sleeve designation incl. nut and locking	Appropriate components		Weight
	nut	locking	kg
H3032	KML32	MBL32	5,21
H3132L	KML32	MBL32	6,4
H2332L	KML32	MBL32	7,95
H3032E	KMFE32	-	5,1
H3132	KM32	MB32	7,67
H3132E	KMFE32	-	7,35
H2332	KM32	MB32	9,14
H3034	KML34	MBL34	5,99
H3134L	KML34	MBL34	7,15
H3034E	KMFE34	-	5,9
H3134	KM34	MB34	8,36
H3134E	KMFE34	-	8,1
H2334	KM34	MB34	10,2
H3936	KML36	MBL36	5,7
H3036	KML36	MBL36	6,83
H3136L	KML36	MBL36	8,15
H3036E	KMFE36	-	6,7
H3136	KM36	MB36	9,5
H2336	KM36	MB36	11,3
H3938	KML38	MBL38	6,2
H3038	KML38	MBL38	7,45
H3138	KM38	MB38	10,8
H2338	KM38	MB38	12,6
H3940	KML40	MBL40	7,9
H3040	KML40	MBL40	9,19
H2340L	KML40	MBL40	13
H3140	KM40	MB40	12,1
H2340	KM40	MB40	13,9
H3944	HM3044	MS3044	7,95
H3044	HM3044	MS3044	9,9
H3144TL	HM3044	MS3044	14,5
H3144	HM44T	MB44	15
H2344	HM44T	MB44	17



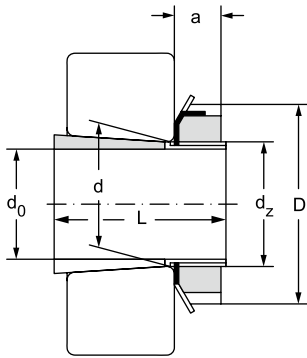

12.13.1

Main dimensions					
d_0	d	d_z	D	L	a
mm					
220	240	Tr240x4	290	101	34
	240	Tr240x4	290	133	34
	240	Tr240x4	290	133	34
	240	Tr240x4	290	172	34
	240	Tr240x4	300	172	37
	240	Tr240x4	300	199	37
240	260	Tr260x4	310	116	34
	260	Tr260x4	310	145	34
	260	Tr260x4	310	145	34
	260	Tr260x4	310	190	34
	260	Tr260x4	330	190	39
	260	Tr260x4	330	211	39
260	280	Tr280x4	330	121	38
	280	Tr280x4	330	152	38
	280	Tr280x4	330	195	38
	280	Tr280x4	350	195	41
	280	Tr280x4	350	224	41
280	300	Tr300x4	360	140	42
	300	Tr300x4	360	168	42
	300	Tr300x4	380	208	40
	300	Tr300x4	380	208	40
	300	Tr300x4	380	240	40
300	320	Tr320x5	380	140	42
	320	Tr320x5	380	171	42
	320	Tr320x5	400	226	42
	320	Tr320x5	400	258	42
320	340	Tr340x5	400	144	45
	340	Tr340x5	400	187	45
	340	Tr340x5	440	254	55
	340	Tr340x5	440	254	55
	340	Tr340x5	440	288	55

Sleeve designation incl. nut and locking	Appropriate components		Weight
	nut	locking	kg
H3948	HM3048	MS3052-48	11
H3048	HM3048	MS3052-48	12
H3048E	HME3048	MS3052-48	11,5
H3148TL	HM3048	MS3052-48	15
H3148	HM48T	MB48	16,5
H2348	HM48T	MB48	19
H3952	HM3052	MS3052-48	11,5
H3052	HM3052	MS3052-48	13,5
H3052E	HME3052	MS3052-48	13,5
H3152TL	HM3052	MS3052-48	17,5
H3152	HM52T	MB52	21
H2352	HM52T	MB52	23
H3956	HM3056	MS3056	15,5
H3056	HM3056	MS3056	16
H3156TL	HM3056	MS3056	19,5
H3156	HM56T	MB56	23
H2356	HM56T	MB56	27
H3960	HM3060	MS3060	20
H3060	HM3060	MS3060	20,5
H3160	HM3160	MS3160	29
H3160E	HME3160	MS3160	27,5
H3260	HM3160	MS3160	32
H3964	HM3064	MS3068-64	21,5
H3064	HM3064	MS3068-64	22
H3164	HM3164	MS3164	32
H3264	HM3164	MS3164	35
H3968	HM3068	MS3068-64	24,5
H3068	HM3068	MS3068-64	27
H3168	HM3168	MS3172-68	50
H3168E	HME3168	MS3172-68	46
H3268	HM3168	MS3172-68	51,5



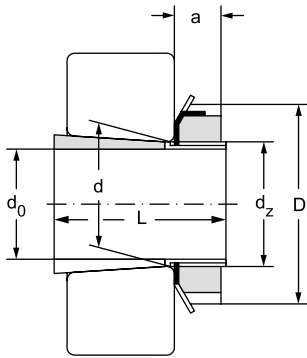

12.13.1

Main dimensions					
d_0	d	d_z	D	L	a
mm					
340	360	Tr360x5	420	144	45
	360	Tr360x5	420	144	45
	360	Tr360x5	420	188	45
	360	Tr360x5	460	259	58
	360	Tr360x5	460	299	58
360	380	Tr380x5	450	164	48
	380	Tr380x5	450	164	48
	380	Tr380x5	450	193	48
	380	Tr380x5	490	264	60
	380	Tr380x5	490	310	60
380	400	Tr400x5	470	168	52
	400	Tr400x5	470	168	52
	400	Tr400x5	470	210	52
	400	Tr400x5	520	272	62
	400	Tr400x5	520	328	62
400	420	Tr420x5	490	168	52
	420	Tr420x5	490	168	52
	420	Tr420x5	490	212	52
	420	Tr420x5	540	304	70
	420	Tr420x5	540	352	70
410	440	Tr440x5	520	189	60
	440	Tr440x5	520	189	60
	440	Tr440x5	520	228	60
	440	Tr440x5	520	228	60
	440	Tr440x5	560	307	70
	440	Tr440x5	560	361	70
430	460	Tr460x5	540	189	60
	460	Tr460x5	540	234	60
	460	Tr460x5	580	326	75
	460	Tr460x5	580	382	75

Sleeve designation incl. nut and locking	Appropriate components		Weight
	nut	locking	kg
H3972	HM3072	MS3072	25
H3972E	HME3072	MS3072	24,5
H3072	HM3072	MS3072	29
H3172	HM3172	MS3172-68	56
H3172E	HME3172	MS3172-68	52
H3272	HM3172	MS3172-68	60,5
H3976	HM3076	MS3080-76	31,5
H3976E	HME3076	MS3080-76	30,5
H3076	HM3076	MS3080-76	35,5
H3176	HM3176	MS3176	61,5
H3176E	HME3176	MS3176	58
H3276	HM3176	MS3176	69,5
H3980	HM3080	MS3080-76	35
H3980E	HME3080	MS3080-76	34
H3080	HM3080	MS3080-76	40
H3180	HM3180	MS3184-80	73
H3180E	HME3180	MS3184-80	57
H3280	HM3180	MS3184-80	87
H3984	HM3084	MS3084	36
H3984E	HME3084	MS3084	34,5
H3084	HM3084	MS3084	47
H3184	HM3184	MS3184-80	80
H3284	HM3184	MS3184-80	96
H3988	HM3088	MS3092-88	58
H3988E	HME3088	MS3092-88	56
H3088	HM3088	MS3092-88	65
H3088E	HME3088	MS3092-88	63
H3188	HM3188	MS3192-88	95
H3188E	HME3188	MS3192-88	91
H3288	HM3188	MS3192-88	117
H3992	HM3092	MS3092-88	60
H3092	HM3092	MS3092-88	71
H3192	HM3192	MS3192-88	119
H3292	HM3192	MS3192-88	134



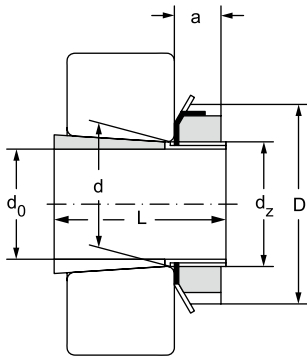

12.13.1

Main dimensions					
d_0	d	d_z	D	L	a
mm					
450	480	Tr480x5	560	200	60
	480	Tr480x5	560	200	60
	480	Tr480x5	560	237	60
	480	Tr480x5	620	335	75
	480	Tr480x5	620	335	75
	480	Tr480x5	620	397	75
200	220	Tr220x4	260	96	30
	220	Tr220x4	260	126	30
	220	Tr220x4	260	161	30
	220	Tr220x4	280	161	35
	220	Tr220x4	280	186	35
220	240	Tr240x4	290	101	34
	240	Tr240x4	290	133	34
	240	Tr240x4	290	133	34
	240	Tr240x4	290	172	34
	240	Tr240x4	300	172	37
	240	Tr240x4	300	199	37
240	260	Tr260x4	310	116	34
	260	Tr260x4	310	145	34
	260	Tr260x4	310	145	34
	260	Tr260x4	310	190	34
	260	Tr260x4	330	190	39
	260	Tr260x4	330	211	39
260	280	Tr280x4	330	121	38
	280	Tr280x4	330	152	38
	280	Tr280x4	330	195	38
	280	Tr280x4	350	195	41
	280	Tr280x4	350	224	41
280	300	Tr300x4	360	140	42
	300	Tr300x4	360	168	42
	300	Tr300x4	380	208	40
	300	Tr300x4	380	208	40
	300	Tr300x4	380	240	40

Sleeve designation incl. nut and locking	Appropriate components		Weight
	nut	locking	kg
H3996	HM3096	MS30/500-96	66
H3996E	HME3096	MS30/500-96	64
H3096	HM3096	MS30/500-96	75
H3196	HM3196	MS3196	135
H3196E	HME3196	MS3196	128
H3296	HM3196	MS3196	153
OH3944H	HM3044	MS3044	7,95
OH3044H	HM3044	MS3044	9,9
OH3144HTL	HM3044	MS3044	14,5
OH3144H	HM44T	MB44	15
OH2344H	HM44T	MB44	17
OH3948H	HM3048	MS3052-48	11
OH3048H	HM3048	MS3052-48	12
OH3048HE	HME3048	MS3052-48	11,5
OH3148HTL	HM3048	MS3052-48	15
OH3148H	HM48T	MB48	16,5
OH2348H	HM48T	MB48	19
OH3952H	HM3052	MS3052-48	11,5
OH3052H	HM3052	MS3052-48	13,5
OH3052HE	HME3052	MS3052-48	13,5
OH3152HTL	HM3052	MS3052-48	17,5
OH3152H	HM52T	MB52	21
OH2352H	HM52T	MB52	23
OH3956H	HM3056	MS3056	15,5
OH3056H	HM3056	MS3056	16
OH3156HTL	HM3056	MS3056	19,5
OH3156H	HM56T	MB56	23
OH2356H	HM56T	MB56	27
OH3960H	HM3060	MS3060	20
OH3060H	HM3060	MS3060	20,5
OH3160H	HM3160	MS3160	29
OH3160HE	HME3160	MS3160	27,5
OH3260H	HM3160	MS3160	32



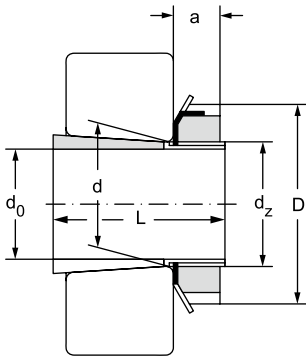

12.13.1

Main dimensions					
d_0	d	d_z	D	L	a
mm					
300	320	Tr320x5	380	140	42
	320	Tr320x5	380	171	42
	320	Tr320x5	400	226	42
	320	Tr320x5	400	258	42
320	340	Tr340x5	400	144	45
	340	Tr340x5	400	187	45
	340	Tr340x5	440	254	55
	340	Tr340x5	440	254	55
	340	Tr340x5	440	288	55
340	360	Tr360x5	420	144	45
	360	Tr360x5	420	144	45
	360	Tr360x5	420	188	45
	360	Tr360x5	460	259	58
	360	Tr360x5	460	259	58
	360	Tr360x5	460	299	58
360	380	Tr380x5	450	164	48
	380	Tr380x5	450	164	48
	380	Tr380x5	450	193	48
	380	Tr380x5	490	264	60
	380	Tr380x5	490	264	60
	380	Tr380x5	490	310	60
380	400	Tr400x5	470	168	52
	400	Tr400x5	470	168	52
	400	Tr400x5	470	210	52
	400	Tr400x5	520	272	62
	400	Tr400x5	520	272	62
	400	Tr400x5	520	328	62
400	420	Tr420x5	490	168	52
	420	Tr420x5	490	168	52
	420	Tr420x5	490	212	52
	420	Tr420x5	540	304	70
	420	Tr420x5	540	352	70

Sleeve designation incl. nut and locking	Appropriate components		Weight
	nut	locking	kg
OH3964H	HM3064	MS3068-64	21,5
OH3064H	HM3064	MS3068-64	22
OH3164H	HM3164	MS3164	32
OH3264H	HM3164	MS3164	35
OH3968H	HM3068	MS3068-64	24,5
OH3068H	HM3068	MS3068-64	27
OH3168H	HM3168	MS3172-68	50
OH3168HE	HME3168	MS3172-68	46
OH3268H	HM3168	MS3172-68	51,5
OH3972H	HM3072	MS3072	25
OH3972HE	HME3072	MS3072	24,5
OH3072H	HM3072	MS3072	29
OH3172H	HM3172	MS3172-68	56
OH3172HE	HME3172	MS3172-68	52
OH3272H	HM3172	MS3172-68	60,5
OH3976H	HM3076	MS3080-76	31,5
OH3976HE	HME3076	MS3080-76	30,5
OH3076H	HM3076	MS3080-76	35,5
OH3176H	HM3176	MS3176	61,5
OH3176HE	HME3176	MS3176	58
OH3276H	HM3176	MS3176	69,5
OH3980H	HM3080	MS3080-76	35
OH3980HE	HME3080	MS3080-76	34
OH3080H	HM3080	MS3080-76	40
OH3180H	HM3180	MS3184-80	73
OH3180HE	HME3180	MS3184-80	57
OH3280H	HM3180	MS3184-80	87
OH3984H	HM3084	MS3084	36
OH3984HE	HME3084	MS3084	34,5
OH3084H	HM3084	MS3084	47
OH3184H	HM3184	MS3184-80	80
OH3284H	HM3184	MS3184-80	96



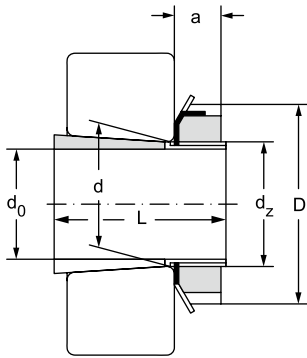

12.13.1

Main dimensions					
d_0	d	d_z	D	L	a
mm					
410	440	Tr440x5	520	189	60
	440	Tr440x5	520	189	60
	440	Tr440x5	520	228	60
	440	Tr440x5	520	228	60
	440	Tr440x5	560	307	70
	440	Tr440x5	560	307	70
	440	Tr440x5	560	361	70
430	460	Tr460x5	540	189	60
	460	Tr460x5	540	234	60
	460	Tr460x5	580	326	75
	460	Tr460x5	580	382	75
450	480	Tr480x5	560	200	60
	480	Tr480x5	560	200	60
	480	Tr480x5	560	237	60
	480	Tr480x5	620	335	75
	480	Tr480x5	620	335	75
	480	Tr480x5	620	397	75
470	500	Tr500x5	580	208	68
	500	Tr500x5	580	208	68
	500	Tr500x5	580	247	68
	500	Tr500x5	630	356	80
	500	Tr500x5	630	428	80
500	530	Tr530x6	630	216	68
	530	Tr530x6	630	216	68
	530	Tr530x6	630	265	68
	530	Tr530x6	670	364	80
	530	Tr530x6	670	447	80
530	560	Tr560x6	650	227	75
	560	Tr560x6	650	227	75
	560	Tr560x6	650	282	75
	560	Tr560x6	710	377	85
	560	Tr560x6	710	377	85
	560	Tr560x6	710	462	85

Sleeve designation incl. nut and locking	Appropriate components		Weight
	nut	locking	kg
OH3988H	HM3088	MS3092-88	58
OH3988HE	HME3088	MS3092-88	56
OH3088H	HM3088	MS3092-88	65
OH3088HE	HME3088	MS3092-88	63
OH3188H	HM3188	MS3192-88	95
OH3188HE	HME3188	MS3192-88	91
OH3288H	HM3188	MS3192-88	117
OH3992H	HM3092	MS3092-88	60
OH3092H	HM3092	MS3092-88	71
OH3192H	HM3192	MS3192-88	119
OH3292H	HM3192	MS3192-88	134
OH3996H	HM3096	MS30/500-96	66
OH3996HE	HME3096	MS30/500-96	64
OH3096H	HM3096	MS30/500-96	75
OH3196H	HM3196	MS3196	135
OH3196HE	HME3196	MS3196	128
OH3296H	HM3196	MS3196	153
OH39/500H	HM30/500	MS30/500-96	74,5
OH39/500HE	HME30/500	MS30/500-96	72,5
OH30/500H	HM30/500	MS30/500-96	82
OH31/500H	HM31/500	MS31/500	145
OH32/500H	HM31/500	MS31/500	170
OH39/530H	HM30/530	MS30/600-530	88
OH39/530HE	HME30/530	MS30/600-530	82,5
OH30/530H	HM30/530	MS30/600-530	105
OH31/530H	HM31/530	MS31/530	161
OH32/530H	HM31/530	MS31/530	192
OH39/560H	HM30/560	MS30/560	95
OH39/560HE	HME30/560	MS30/560	91,5
OH30/560H	HM30/560	MS30/560	112
OH31/560H	HM31/560	MS31/600-560	185
OH31/560HE	HME31/560	MS31/600-560	179
OH32/560H	HM31/560	MS31/600-560	219



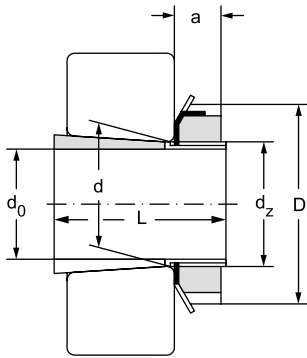

12.13.1

Main dimensions					
d_0	d	d_z	D	L	a
mm					
560	600	Tr600x6	700	239	75
	600	Tr600x6	700	239	75
	600	Tr600x6	700	289	75
	600	Tr600x6	750	399	85
	600	Tr600x6	750	399	85
590	630	Tr630x6	730	254	75
	630	Tr630x6	730	254	75
	630	Tr630x6	730	301	75
	630	Tr630x6	800	424	95
	630	Tr630x6	800	424	95
630	670	Tr670x6	780	264	80
	670	Tr670x6	780	324	80
	670	Tr670x6	850	456	106
	670	Tr670x6	850	456	106
	670	Tr670x6	850	558	106
670	710	Tr710x7	830	286	90
	710	Tr710x7	830	286	90
	710	Tr710x7	830	342	90
	710	Tr710x7	830	342	90
	710	Tr710x7	900	467	106
	710	Tr710x7	900	467	106
	710	Tr710x7	900	572	106
710	750	Tr750x7	870	291	90
	750	Tr750x7	870	291	90
	750	Tr750x7	870	356	90
	750	Tr750x7	870	356	90
	750	Tr750x7	950	493	112
	750	Tr750x7	950	493	112
	750	Tr750x7	950	603	112
750	800	Tr800x7	920	303	90
	800	Tr800x7	920	303	90
	800	Tr800x7	920	366	90
	800	Tr800x7	920	366	90
	800	Tr800x7	1000	505	112
	800	Tr800x7	1000	505	112

Sleeve designation incl. nut and locking	Appropriate components		Weight
	nut	locking	
			kg
OH39/600H	HM30/600	MS30/600-530	127
OH39/600HE	HME30/600	MS30/600-530	122
OH30/600H	HM30/600	MS30/600-530	147
OH31/600H	HM31/600	MS31/600-560	234
OH31/600HE	HME31/600	MS31/600-560	228
OH32/600H	HM31/600	MS31/600-560	278
OH39/630H	HM30/630	MS30/630	124
OH39/630HE	HME30/630	MS30/630	119
OH30/630H	HM30/630	MS30/630	138
OH31/630H	HM31/630	MS31/630	254
OH31/630HE	HME31/630	MS31/630	244
OH39/670H	HM30/670	MS30/670	162
OH30/670H	HM30/670	MS30/670	190
OH31/670H	HM31/670	MS31/670	340
OH31/670HE	HME31/670	MS31/670	329
OH32/670H	HM31/670	MS31/670	401
OH39/710H	HM30/710	MS30/710	183
OH39/710HE	HME30/710	MS30/710	173
OH30/710H	HM30/710	MS30/710	228
OH30/710HE	HME30/710	MS30/710	183
OH31/710H	HM31/710	MS31/710	392
OH31/710HE	HME31/710	MS31/710	379
OH32/710H	HM31/710	MS31/710	459
OH39/750H	HM30/750	MS30/800-750	211
OH39/750HE	HME30/750	MS30/800-750	203
OH30/750H	HM30/750	MS30/800-750	246
OH30/750HE	HME30/750	MS30/800-750	238
OH31/750H	HM31/750	MS31/800-750	451
OH31/750HE	HME31/750	MS31/800-750	438
OH32/750H	HM31/750	MS31/800-750	526
OH39/800H	HM30/800	MS30/800-750	259
OH39/800HE	HME30/800	MS30/800-750	250
OH30/800H	HM30/800	MS30/800-750	302
OH30/800HE	HME30/800	MS30/800-750	293
OH31/800H	HM31/800	MS31/800-750	535
OH31/800HE	HME31/800	MS31/800-750	520



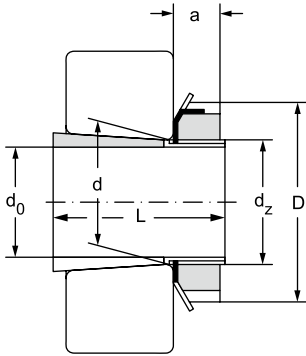

Main dimensions					
d_0	d	d_z	D	L	a
mm					
800	850	Tr850x7	980	308	90
	850	Tr850x7	980	308	90
	850	Tr850x7	980	380	90
	850	Tr850x7	980	380	90
	850	Tr850x7	1060	536	118
850	850	Tr850x7	1060	536	118
	900	Tr900x7	1030	326	100
	900	Tr900x7	1030	326	100
	900	Tr900x7	1030	400	100
	900	Tr900x7	1030	400	100
900	900	Tr900x7	1120	557	125
	900	Tr950x8	1080	344	100
	950	Tr950x8	1080	344	100
	950	Tr950x8	1080	420	100
	950	Tr950x8	1080	420	100
950	950	Tr950x8	1170	583	125
	950	Tr1000x8	1140	358	100
	1000	Tr1000x8	1140	430	100
	1000	Tr1000x8	1140	430	100
	1000	Tr1000x8	1240	609	125
1000	1000	Tr1000x8	1240	609	125
	1060	Tr1060x8	1200	372	100
	1060	Tr1060x8	1200	372	100
	1060	Tr1060x8	1200	447	100
	1060	Tr1060x8	1300	622	125

12.13.1

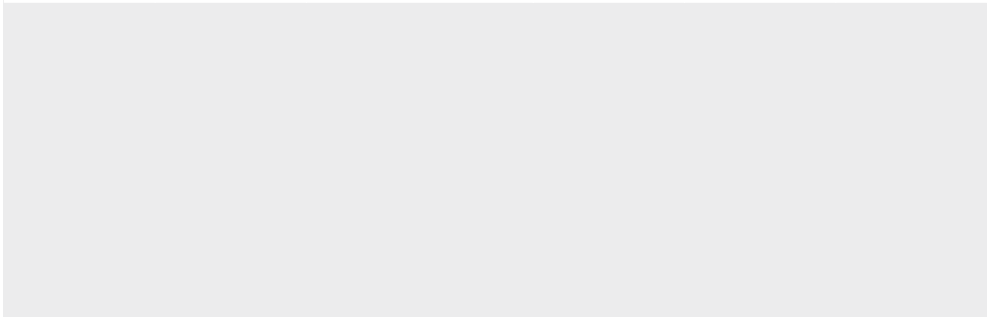

Sleeve designation incl. nut and locking	Appropriate components		Weight
	nut	locking	kg
OH39/850H	HM30/850	MS30/900-850	288
OH39/850HE	HME30/850	MS30/900-850	277
OH30/850H	HM30/850	MS30/900-850	341
OH30/850HE	HME30/850	MS30/900-850	330
OH31/850H	HM31/850	MS31/850	616
OH31/850HE	HME31/850	MS31/850	594
OH39/900H	HM30/900	MS30/900-850	330
OH39/900HE	HME30/900	MS30/900-850	316
OH30/900H	HM30/900	MS30/900-850	387
OH30/900HE	HME30/900	MS30/900-850	373
OH31/900H	HM31/900	MS31/900	677
OH39/950H	HM30/950	MS30/950	363
OH39/950HE	HME30/950	MS30/950	348
OH30/950H	HM30/950	MS30/950	424
OH30/950HE	HME30/950	MS30/950	409
OH31/950H	HM31/950	MS31/950	738
OH39/1000H	HM30/1000	MS30/1000	407
OH30/1000H	HM30/1000	MS30/1000	470
OH30/1000HE	HME30/1000	MS30/1000	454
OH31/1000H	HM31/1000	MS31/1000	842
OH31/1000HE	HME31/1000	MS31/1000	811
OH39/1060H	HM30/1060	MS30/1000	490
OH39/1060HE	HME30/1060	MS30/1000	473
OH30/1060H	HM30/1060	MS30/1000	571
OH31/1060H	HM31/1060	MS31/1000	984



Withdrawal sleeve d = 35 to 180 mm

d = 35 to 95 mm

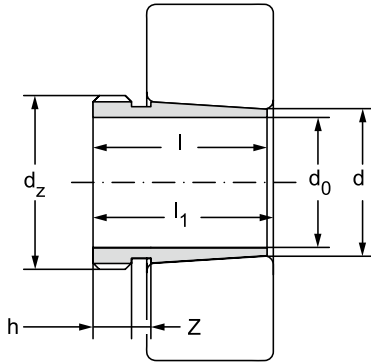

12.13.2

Main dimensions						
d ₀	d	d _z	l	l ₁	h	z
mm						
35	40	M45x1,5	30	32	6	5
	40	M45x1,5	40	43	7	6
40	45	M50x1,5	32	34	6	6
	45	M50x1,5	44	47	7	6
45	50	M55x2	35	38	7	6
	50	M55x2	50	53	8	6
50	55	M60x2	37	40	7	6
	55	M60x2	54	57	9	6
55	60	M65x2	40	43	8	7
	60	M65x2	57	61	10	7
60	65	M70x2	42	45	8	7
	65	M75x2	42	45	8	7
	65	M70x2	61	64	11	7
	65	M75x2	61	64	11	7
65	70	M75x2	44	47	8	7
	70	M80x2	44	47	8	7
	70	M75x2	65	68	12	7
	70	M80x2	65	68	12	7
70	75	M80x2	46	49	8	7
	75	M85x2	46	49	8	7
	75	M80x2	69	72	12	7
	75	M85x2	69	72	12	7
75	80	M90x2	48	52	8	7
	80	M90x2	72	75	12	7
80	85	M95x2	52	56	9	7
	85	M95x2	75	78	13	7
85	90	M100x2	53	57	9	7
	90	M100x2	63	67	10	7
	90	M100x2	80	83	14	7

Sleeve designation	Corresp. withdrawal nut	Weight
		kg
AH308	KM9	0,093
AH2308	KM9	0,129
AH309	KM10	0,112
AH2309	KM10	0,163
AHX310	KM11	0,138
AHX2310	KM11	0,236
AHX311	KM12	0,162
AHX2311	KM12	0,257
AHX312	KM13	0,194
AHX2312	KM13	0,299
AH313G	KM14	0,22
AH313	KM15	0,256
AH2313G	KM14	0,36
AH2313	KM15	0,399
AH314G	KM15	0,24
AH314	KM16	0,29
AHX2314G	KM15	0,42
AHX2314	KM16	0,466
AH315G	KM16	0,326
AH315	KM17	0,326
AHX2315G	KM16	0,536
AHX2315	KM17	0,536
AH316	KM18	0,367
AHX2316	KM18	0,602
AHX317	KM19	0,431
AHX2317	KM19	0,676
AHX318	KM20	0,465
AHX3218	KM20	0,578
AHX2318	KM20	0,777



Withdrawal sleeve

d = 100 to 160 mm

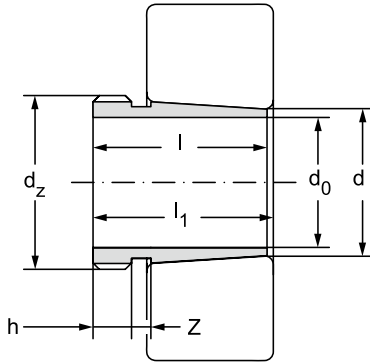

12.13.2

Main dimensions						
d ₀	d	d _z	l	l ₁	h	z
mm						
90	95	M105x2	57	61	10	8
	95	M105x2	85	89	15	8
95	100	M110x2	59	63	10	8
	100	M110x2	64	68	11	8
	100	M110x2	75	77	12	7
	100	M110x2	90	94	15	8
100	110	M125x2	68	72	11	8
105	110	M120x2	63	67	12	8
	110	M120x2	68	72	11	8
	110	M120x2	82	86	12	8
	110	M125x2	82	86	12	8
	110	M115x2	82	91	13	8
	110	M120x2	98	102	16	8
110	120	M140x2	75	79	12	8
	120	M140x2	105	109	17	8
115	120	M130x2	60	64	13	8
	120	M125x2	73	82	13	8
	120	M130x2	75	79	12	8
	120	M130x2	90	94	14	8
	120	M135x2	90	94	14	8
	120	M130x2	93	102	13	8
	120	M130x2	105	109	17	8
	120	M135x2	105	109	17	8
125	130	M140x2	67	71	14	8
	130	M140x2	78	82	12	8
	130	M135x2	83	93	14	8
	130	M140x2	94	104	14	8
	130	M140x2	98	102	15	8
	130	M145x2	98	102	15	8
	130	M140x2	115	119	19	8
	130	M145x2	115	119	19	8

Sleeve designation	Corresp. withdrawal nut	Weight
		kg
AHX319	KM21	0,537
AHX2319	KM21	0,888
AHX320	KM22	0,586
AHX3120	KM22	0,76
AHX3220	KM22	0,768
AHX2320	KM22	1
AH3122	KM25	1,28
AHX322	KM24	0,77
AHX3122	KM24	0,786
AHX3222G	KM24	1
AHX3222	KM25	1,06
AH24122	KM23	0,71
AHX2322G	KM24	1,3
AHX2322	KM25	1,35
AH3124	KM28	1,67
AH2324	KM28	2,47
AHX3024	KM26	0,737
AH24024	KM25	0,7
AHX3124	KM26	0,948
AHX3224G	KM26	1,3
AHX3224	KM27	1,31
AH24124	KM26	1
AHX2324G	KM26	1,55
AHX2324	KM27	1,61
AHX3026	KM28	0,907
AHX3126	KM28	1,08
AH24026	KM27	0,88
AH24126	KM28	1,15
AHX3226G	KM28	1,5
AHX3226	KM29	1,58
AHX2326G	KM28	1,85
AHX2326	KM29	1,97



Withdrawal sleeve

d = 170 to 180 mm

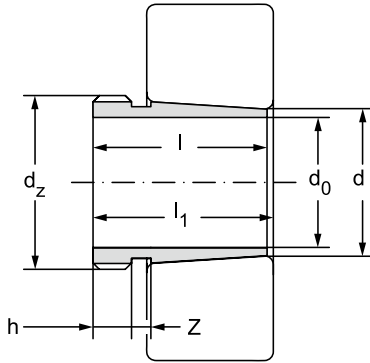

Main dimensions						
d ₀	d	d _z	l	l ₁	h	z
mm						
135	140	M150x2	68	73	14	10
	140	M150x2	83	88	14	10
	140	M145x2	83	93	14	10
	140	M150x2	99	109	14	10
	140	M150x2	104	109	15	10
	140	M155x3	104	109	15	10
	140	M150x2	125	130	20	10
	140	M155x3	125	130	20	10
145	150	M160x3	72	77	15	10
	150	M155x3	90	101	15	10
	150	M160x3	96	101	15	10
	150	M165x3	96	101	15	10
	150	M160x3	114	119	18	10
	150	M165x3	114	119	18	10
	150	M160x3	115	126	15	10
	150	M160x3	135	140	24	10
150	M165x3	135	140	24	10	
150	160	M170x3	77	82	16	10
	160	M170x3	95	106	15	10
	160	M170x3	103	108	16	10
	160	M180x3	103	108	16	10
	160	M170x3	124	130	20	12
	160	M180x3	124	130	20	12
	160	M170x3	124	135	15	12
	160	M170x3	140	146	24	12
160	M180x3	140	146	24	12	
160	170	M180x3	85	90	17	10
	170	M180x3	104	109	16	10
	170	M190x3	104	109	16	10
	170	M180x3	106	117	16	10
	170	M180x3	125	135	16	10
	170	M180x3	134	140	24	12
	170	M190x3	134	140	24	12
	170	M180x3	146	152	24	12
170	M190x3	146	152	24	12	

Sleeve designation	Corresp. withdrawal nut	Weight
		kg
AHX3028	KM30	0,996
AHX3128	KM30	1,26
AH24028	KM29	0,95
AH24128	KM30	1,3
AHX3228G	KM31	1,75
AHX3228	KM31	1,81
AHX2328G	KM31	2,25
AHX2328	KM31	2,34
AHX3030	KM32	1,12
AH24030	KM31	1,05
AHX3130G	KM32	1,7
AHX3130	KM33	1,75
AHX3230G	KM32	2,21
AHX3230	KM33	2,21
AH24130	KM32	1,55
AHX2330G	KM32	3,7
AHX2330	KM33	3,7
AH3032	KM34	2,01
AH24032	KM34	2,3
AH3132G	KM34	3
AH3132	KM36	3,18
AH3232G	KM34	3,7
AH3232	KM36	4,02
AH24132	KM34	1,55
AH2332G	KM34	4,35
AH2332	KM36	4,69
AH3034	KM36	2,4
AH3134G	KM36	3,2
AH3134	KM38	3,41
AH24034	KM36	2,7
AH24134	KM36	3,25
AH3234G	KM36	4,35
AH3234	KM38	3,41
AH2334G	KM38	4,85
AH2334	KM38	5,23



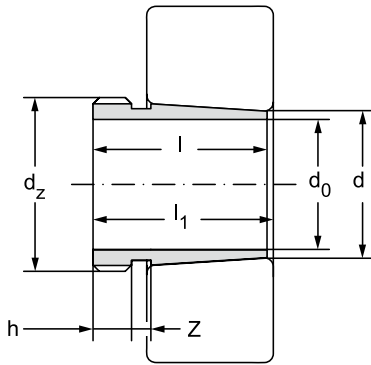

12.13.2

Main dimensions						
d_0	d	d_z	l	l_1	h	z
mm						
170	180	M190x3	92	98	17	12
	180	M190x3	105	110	17	10
	180	M200x3	105	110	17	10
	180	M190x3	116	122	19	12
	180	M200x3	116	122	19	12
	180	M190x3	116	127	16	12
	180	M190x3	134	145	16	12
	180	M200x3	140	146	24	12
	180	M200x3	154	160	26	12
180	190	M200x3	96	102	17	12
	190	M200x3	112	117	18	10
	190	M200x3	118	131	18	12
	190	M200x3	125	131	19	12
	190	M200x3	145	152	25	14
	190	M200x3	146	159	18	12
	190	M200x3	160	167	26	14
190	200	Tr210x4	102	108	19	
	200	Tr210x4	127	140	18	
	200	Tr220x4	134	140	21	
	200	Tr220x4	153	160	25	
	200	Tr210x4	158	171	18	
	200	Tr220x4	170	177	30	
200	220	Tr230x4	111	117	20	
	220	Tr230x4	138	152	20	
	220	Tr240x4	145	151	23	
	220	Tr230x4	170	184	20	
	220	Tr240x4	181	189	30	
220	240	Tr260x4	116	123	21	
	240	Tr250x4	138	153	20	
	240	Tr260x4	154	161	25	
	240	Tr260x4	180	195	20	
	240	Tr260x4	189	197	30	

Sleeve designation	Corresp. withdrawal nut	Weight
		kg
AH3036	KM38	2,8
AH2236G	KM38	3,4
AH2236	KM40	3,67
AH3136G	KM38	3,9
AH3136	KM40	4,16
AH24036	KM38	3,2
AH24136	KM38	3,75
AH3236	KM40	5,29
AH2336	KM40	5,94
AH3038G	KM40	3,28
AH2238G	KM40	4,15
AH24038	KM40	3,55
AH3138G	KM40	4,73
AH3238	KM40	5,8
AH24138	KM40	4,45
AH2338	KM40	6,53
AH3040G	HM42T	3,7
AH24040	HM42T	4
AH3140	HM3044	5,65
AH3240	HM3044	6,6
AH24140	HM42T	5,05
AH2340	HM3044	7,6
AOH3044G	HM46T	7,3
AOH24044	HM46T	7,45
AOH3144	HM3048	9,3
AOH24144	HM46T	10
AOH2344	HM3048	13,5
AOH3048	HM3052	7,95
AOH24048	HM50T	8,05
AOH3148	HM3052	12
AOH24148	HM3052	11,5
AOH2348	HM3052	14



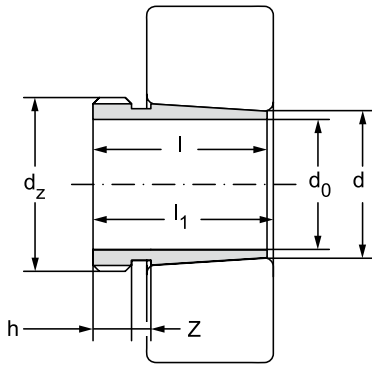

12.13.2

Main dimensions						
d_0	d	d_z	l	l_1	h	z
mm						
240	260	Tr280x4	128	135	23	
	260	Tr280x4	155	161	23	
	260	Tr280x4	162	178	22	
	260	Tr280x4	172	179	26	
	260	Tr280x4	202	218	22	
	260	Tr280x4	205	213	30	
260	280	Tr300x4	131	139	24	
	280	Tr300x4	155	163	24	
	280	Tr300x4	162	179	22	
	280	Tr300x4	175	183	28	
	280	Tr300x4	202	219	22	
	280	Tr300x4	212	220	30	
280	300	Tr320x5	145	153	26	
	300	Tr320x5	170	178	26	
	300	Tr320x5	184	202	24	
	300	Tr320x5	192	200	30	
	300	Tr320x5	224	242	24	
	300	Tr320x5	228	236	34	
300	320	Tr340x5	149	157	27	
	320	Tr340x5	180	190	27	
	320	Tr340x5	184	202	24	
	320	Tr340x5	209	217	31	
	320	Tr340x5	242	260	24	
	320	Tr340x5	246	254	36	
320	340	Tr360x5	162	171	28	
	340	Tr360x5	206	225	26	
	340	Tr360x5	225	234	33	
	340	Tr360x5	264	273	38	
	340	Tr360x5	269	288	26	
340	360	Tr380x5	167	176	30	
	360	Tr380x5	206	226	26	
	360	Tr380x5	229	238	35	
	360	Tr380x5	269	289	26	
	360	Tr380x5	274	283	40	

Sleeve designation	Corresp. withdrawal nut	Weight
		kg
AOH3052	HM3056	9,55
AOH2252G	HM3056	13,5
AOH24052G	HM3056	12,5
AOH3152G	HM3056	15,5
AOH24152	HM3056	14
AOH2352G	HM3056	19
AOH3056	HM3060	11
AOH2256G	HM3160	15
AOH24056G	HM3160	13,5
AOH3156G	HM3160	17
AOH24156	HM3160	15
AOH2356G	HM3160	21,5
AOH3060	HM3064	13
AOH2260G	HM3164	17,5
AOH24060G	HM3164	17
AOH3160G	HM3164	20,5
AOH24160	HM3164	18,5
AOH3260G	HM3164	23,5
AOH3064G	HM3068	16,5
AOH2264G	HM3168	20
AOH24064G	HM3168	18
AOH3164G	HM3168	24,5
AOH24164	HM3168	20,5
AOH3264G	HM3168	27,5
AOH3068G	HM3072	19
AOH24068	HM3172	18
AOH3168G	HM3172	28,5
AOH3268G	HM3172	32
AOH24168	HM3172	25,5
AOH3072G	HM3076	21
AOH24072	HM3176	20
AOH3172G	HM3176	30,5
AOH24172	HM3176	26
AOH3272G	HM3176	35,5



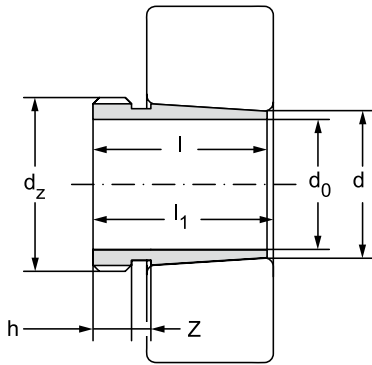

12.13.2

Main dimensions						
d_0	d	d_z	l	l_1	h	z
mm						
360	380	Tr400x5	170	180	31	
	380	Tr400x5	208	228	28	
	380	Tr400x5	232	242	36	
	380	Tr400x5	271	291	28	
	380	Tr400x5	284	294	42	
380	400	Tr420x5	183	193	33	
	400	Tr420x5	228	248	28	
	400	Tr420x5	240	250	38	
	400	Tr420x5	278	298	28	
	400	Tr420x5	302	312	44	
400	420	Tr440x5	186	196	34	
	420	Tr440x5	230	252	30	
	420	Tr440x5	266	276	40	
	420	Tr440x5	310	332	30	
	420	Tr440x5	321	331	46	
420	440	Tr460x5	194	205	35	
	440	Tr460x5	242	264	30	
	440	Tr460x5	270	281	42	
	440	Tr460x5	310	332	30	
	440	Tr460x5	330	341	48	
440	460	Tr480x5	202	213	37	
	460	Tr480x5	250	273	32	
	460	Tr480x5	285	296	43	
	460	Tr480x5	332	355	32	
	460	Tr480x5	349	360	50	
460	480	Tr500x5	205	217	38	
	480	Tr500x5	250	273	32	
	480	Tr500x5	295	307	45	
	480	Tr500x5	340	363	32	
	480	Tr500x5	364	376	52	
480	500	Tr530x6	209	221	40	
	500	Tr530x6	253	276	35	
	500	Tr530x6	313	325	47	
	500	Tr530x6	360	383	35	
	500	Tr530x6	393	405	54	

Sleeve designation	Corresp. withdrawal nut	Weight
		kg
AOH3076G	HM3080	22,5
AOH24076	HM3180	23,5
AOH3176G	HM3180	33
AOH24176	HM3180	31
AOH3276G	HM3180	42
AOH3080G	HM3084	26
AOH24080	HM3184	27
AOH3180G	HM3184	36
AOH24180	HM3184	35
AOH3280G	HM3184	48
AOH3084G	HM3088	28
AOH24084	HM3188	29
AOH3184G	HM3188	43
AOH24184	HM3188	39
AOH3284G	HM3188	54,5
AOHX3088G	HM3092	31
AOH24088	HM3192	32
AOHX3188G	HM3192	46
AOH24188	HM3192	45,5
AOHX3288G	HM3192	59
AOHX3092G	HM3096	34
AOH24092	HM3196	34,5
AOHX3192G	HM3196	51,5
AOH24192	HM3196	50
AOHX3292G	HM3196	66,5
AOHX3096G	HM30/500	34
AOH24096	HM31/500	36,5
AOHX3196G	HM31/500	56
AOH24196	HM31/500	51,5
AOHX3296G	HM31/500	73,5
AOHX30/500G	HM30/530	41
AOH240/500	HM31/530	43
AOHX31/500G	HM31/530	66,5
AOH241/500	HM31/530	62,5
AOHX32/500G	HM31/530	89,5



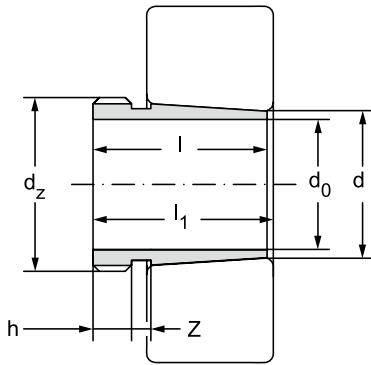

Main dimensions						
d_0	d	d_z	l	l_1	h	z
mm						
500	530	Tr560x6	230	242	45	
	530	Tr560x6	285	309	35	
	530	Tr560x6	325	337	53	
	530	Tr560x6	370	394	35	
	530	Tr560x6	412	424	57	
530	560	Tr600x6	240	252	45	
	560	Tr600x6	296	320	38	
	560	Tr600x6	335	347	55	
	560	Tr600x6	393	417	38	
	560	Tr600x6	422	434	57	
570	600	Tr630x6	245	259	45	
	600	Tr630x6	310	336	38	
	600	Tr630x6	355	369	55	
	600	Tr630x6	413	439	38	
	600	Tr630x6	445	459	57	
600	630	Tr670x6	258	272	46	
	630	Tr670x6	330	356	40	
	630	Tr670x6	375	389	60	
	630	Tr670x6	440	466	40	
	630	Tr670x6	475	489	63	
630	670	Tr710x7	280	294	50	
	670	Tr710x7	348	374	40	
	670	Tr710x7	395	409	59	
	670	Tr710x7	452	478	40	
	670	Tr710x7	500	514	62	
670	710	Tr750x7	286	302	50	
	710	Tr750x7	360	386	45	
	710	Tr750x7	405	421	60	
	710	Tr750x7	483	509	45	
	710	Tr750x7	515	531	65	
710	750	Tr800x7	300	316	50	
	750	Tr800x7	380	408	45	
	750	Tr800x7	425	441	60	
	750	Tr800x7	520	548	45	
	750	Tr800x7	540	556	65	

Sleeve designation	Corresp. withdrawal nut	Weight
		kg
AOH30/530	HM30/560	63,5
AOH240/530G	HM31/560	64,5
AOH31/530	HM31/560	93,5
AOH241/530G	HM31/560	92
AOH32/530G	HM31/560	127
AOHX30/560	HM30/600	73,5
AOH240/560G	HM31/600	79,5
AOH31/560	HM31/600	107
AOH241/560G	HM31/600	107
AOHX32/560	HM31/600	143
AOHX30/600	HM30/630	77
AOHX240/600	HM31/630	86,5
AOHX31/600	HM31/630	120
AOHX241/600	HM31/630	118
AOHX32/600G	HM31/630	159
AOH30/630	HM30/670	88,5
AOH240/630G	HM31/670	101
AOH31/630	HM31/670	139
AOH241/630G	HM31/670	139
AOH32/630G	HM31/670	188
AOH30/670	HM30/710	125
AOH240/670G	HM31/710	141
AOHX31/670	HM31/710	189
AOH241/670	HM31/710	185
AOH32/670G	HM31/710	252
AOHX30/710	HM30/750	139
AOH240/710G	HM31/750	155
AOHX31/710	HM31/750	207
AOH241/710	HM31/750	212
AOH32/710G	HM31/750	278
AOH30/750	HM30/800	145
AOH240/750G	HM31/800	179
AOH31/750	HM31/800	238
AOH241/750G	HM31/800	248
AOH32/750	HM31/800	320



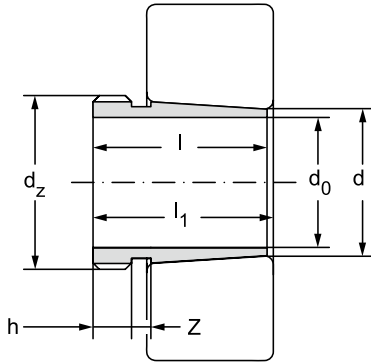

12.13.2

Main dimensions						
d_0	d	d_z	l	l_1	h	z
mm						
750	800	Tr850x7	308	326	50	
	800	Tr850x7	395	423	50	
	800	Tr850x7	438	456	63	
	800	Tr850x7	525	553	50	
	800	Tr850x7	550	568	67	
800	850	Tr900x7	325	343	53	
	850	Tr900x7	415	445	50	
	850	Tr900x7	462	480	62	
	850	Tr900x7	560	600	60	
	850	Tr900x7	585	603	70	
850	900	Tr950x8	335	355	55	
	900	Tr950x8	430	475	55	
	900	Tr950x8	475	495	63	
	900	Tr950x8	575	620	60	
	900	Tr950x8	585	605	70	
900	950	Tr1000x8	355	375	55	
	950	Tr1000x8	467	512	55	
	950	Tr1000x8	500	520	62	
	950	Tr1000x8	600	620	70	
	950	Tr1000x8	605	650	60	
950	1000	Tr1060x8	365	387	57	
	1000	Tr1060x8	469	519	57	
	1000	Tr1060x8	525	547	63	
	1000	Tr1060x8	630	652	70	
	1000	Tr1060x8	645	695	65	
1000	1060	Tr1120x8	385	407	60	
	1060	Tr1120x8	498	548	60	
	1060	Tr1120x8	540	562	65	
	1060	Tr1120x8	665	715	65	

Sleeve designation	Corresp. withdrawal nut	Weight
		kg
AOH30/800	HM30/850	204
AOH240/800G	HM31/850	237
AOH31/800	HM31/850	305
AOH241/800G	HM31/850	318
AOH32/800	HM31/850	401
AOH30/850	HM30/900	230
AOH240/850G	HM31/900	265
AOH31/850	HM31/900	345
AOH241/850	HM31/900	368
AOH32/850	HM31/900	461
AOH30/900	HM30/950	250
AOH240/900	HM31/950	296
AOH31/900	HM31/950	379
AOH241/900	HM31/950	402
AOH32/900	HM31/950	489
AOH30/950	HM30/1000	285
AOH240/950	HM31/1000	340
AOH31/950	HM31/1000	426
AOH32/950	HM31/1000	533
AOH241/950	HM31/1000	449
AOH30/1000	HM30/1060	318
AOH240/1000	HM31/1060	369
AOH31/1000	HM31/1060	485
AOH32/1000	HM31/1060	608
AOH241/1000	HM31/1060	519
AOH30/1060	HM30/1120	406
AOH240/1060	HM30/1120	479
AOH31/1060	HM30/1120	599
AOH241/1060	HM30/1120	652



Adapter and withdrawal round nuts

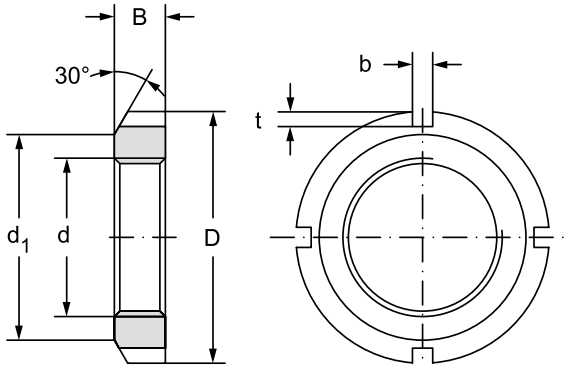

12.13.3

Main dimensions					
d	d	d ₁	B	b	t
mm					
M10x0,75	18	13,5	4	3	2
M12x1	22	17	4	3	2
M15x1	25	21	5	4	2
M17x1	28	24	5	4	2
M20x1	32	26	6	4	2
M25x1,5	38	32	7	5	2
M30x1,5	45	38	7	5	2
M35x1,5	52	44	8	5	2
M40x1,5	58	50	9	6	2,5
M45x1,5	65	56	10	6	2,5
M50x1,5	70	61	11	6	2,5
M55x2	75	67	11	7	3
M60x2	80	73	11	7	3
M65x2	85	79	12	7	3
M70x2	92	85	12	8	3,5
M75x2	98	90	13	8	3,5
M80x2	105	95	15	8	3,5
M85x2	110	102	16	8	3,5
M90x2	120	108	16	10	4
M95x2	125	113	17	10	4
M100x2	130	120	18	10	4

Nut designation		Corresp. locking washer	Weight
KM	KMA		kg
KM0	MB0		0,004
KM1	MB1		0,007
KM2	MB2		0,01
KM3	MB3		0,013
KM4	MB4		0,019
KM5	KMA5	MB5	0,025
KM6	KMA6	MB6	0,043
KM7	KMA7	MB7	0,053
KM8	KMA8	MB8	0,085
KM9	KMA9	MB9	0,12
KM10	KMA10	MB10	0,15
KM11	KMA11	MB11	0,16
KM12	KMA12	MB12	0,17
KM13	KMA13	MB13	0,2
KM14	KMA14	MB14	0,24
KM15	KMA15	MB15	0,29
KM16	KMA16	MB16	0,4
KM17	KMA17	MB17	0,45
KM18	KMA18	MB18	0,56
KM19	MB19		0,66
KM20	KMA20	MB20	0,7



Adapter and withdrawal round nuts

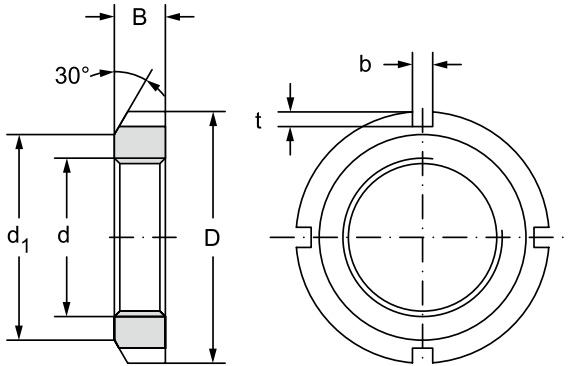

12.13.3

Main dimensions					
d	d	d ₁	B	b	t
mm					
M105x2	140	126	18	12	5
M110x2	145	133	19	12	5
M115x2	150	137	19	12	5
M120x2	155	138	20	12	5
M125x2	160	148	21	12	5
M130x2	165	149	21	12	6
M135x2	175	160	22	14	6
M140x2	180	160	22	14	6
M150x2	195	171	24	14	6
M160x3	210	182	25	16	7
M170x3	220	193	26	16	7
M180x3	230	203	27	18	8
M190x3	240	214	28	18	8
M200x3	250	226	29	18	8

Nut designation		Corresp. locking washer	Weight
KM	KMA		kg
KM21	KMA21	MB21	0,84
KM22	KMA22	MB22	0,97
KM23	MB23		1,01
KM24	KMA24	MB24	1,08
KM25	KMA25	MB25	1,19
KM26	KMA26	MB26	1,25
KM27	MB27		1,55
KM28	MB28		1,6
KM30	MB30		2,03
KM32	MB32		2,59
KM34	MB34		2,8
KM36	MB36		3,07
KM38	MB38		3,39
KM40	MB40		3,69



Safety mats d = 10 to 200 mm

d = 10 to 100 mm

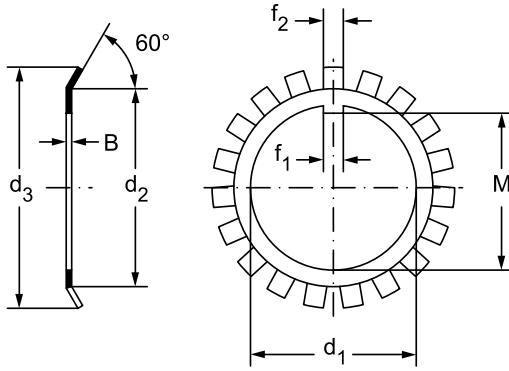

12.13.4

Main dimensions						
d_1	d_2	d_3	B	f_1	f_2	M
mm						
10	13,5	21	1	3	3	8,5
12	17	25	1	3	3	10,5
15	21	28	1	4	4	13,5
17	24	32	1	4	4	15,5
20	26	36	1	4	4	18,5
25	32	42	1,25	5	5	23
30	38	49	1,25	5	5	27,5
35	44	57	1,25	6	5	32,5
40	50	62	1,25	6	6	37,5
45	56	69	1,25	6	6	42,5
50	61	74	1,25	6	6	47,5
55	67	81	1,5	8	7	52,5
60	73	86	1,5	8	7	57,5
65	79	92	1,5	8	7	62,2
70	85	98	1,5	8	8	66,5
75	90	104	1,5	8	8	71,5
80	95	112	1,8	10	8	76,5
85	102	119	1,8	10	8	81,5
90	108	126	1,8	10	10	86,5
95	113	133	1,8	10	10	91,5
100	120	140	1,8	12	10	96,5

Locking washers designation	Weight 100 pcs.
	kg
MB0	0,13
MB1	0,2
MB2	0,26
MB3	0,32
MB4	0,35
MB5	0,64
MB6	0,78
MB7	1,04
MB8	1,23
MB9	1,52
MB10	1,6
MB11	1,96
MB12	2,53
MB13	2,9
MB14	3,34
MB15	3,56
MB16	4,64
MB17	5,24
MB18	6,23
MB19	6,7
MB20	7,65



Safety mats

d = 105 to 200 mm

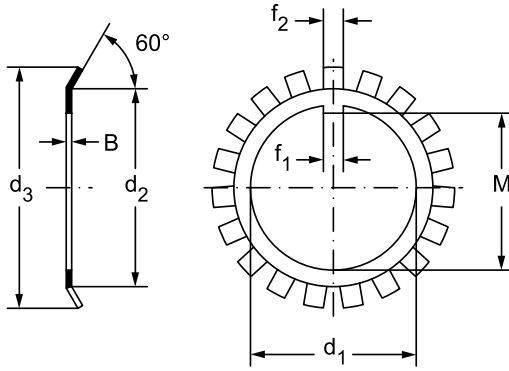

12.13.4

Main dimensions						
d_1	d_2	d_3	B	f_1	f_2	M
mm						
105	126	145	1,8	12	12	100,5
110	133	154	1,8	12	12	105,5
115	137	159	2	12	12	110,5
120	135	148	2	14	12	115
	138	164	2	14	12	115
125	148	170	2	14	12	120
130	149	175	2	14	12	125
135	160	185	2	14	14	130
140	160	192	2	16	14	135
150	171	205	2	16	14	145
160	182	217	2,5	18	16	154
170	193	232	2,5	18	16	164
180	203	242	2,5	20	18	174
190	214	252	2,5	20	18	184
200	226	262	2,5	20	18	194

Locking washers designation	Weight 100 pcs.
	kg
MB21	8,26
MB22	9,4
MB23	10,8
MBL24	7
MB24	10,5
MB25	11,8
MB26	11,3
MB27	14,4
MB28	14,2
MB30	15,5
MB32	22,2
MB34	24,7
MB36	16,8
MB38	27,8
MB40	29,3



Snap rings for roller bearings with a groove on the outer ring

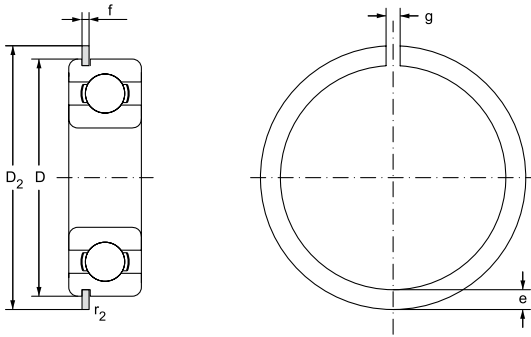

Main dimensions					
D	D ₂ ¹⁾	e	f	g ¹⁾	r ₂
	max	max	max	max	min
mm					
32	36,7	3,25	1,12	3	0,4
35	39,7	3,25	1,12	3	0,4
40	44,6	3,25	1,12	3	0,4
42	46,3	3,25	1,12	3	0,4
47	52,7	4,04	1,12	4	0,4
52	57,9	4,04	1,12	4	0,4
55	60,7	4,04	1,12	4	0,6
62	67,7	4,04	1,7	4	0,6
68	74,6	4,85	1,7	5	0,6
72	78,6	4,85	1,7	5	0,6
75	81,6	4,85	1,7	5	0,6
80	86,6	4,85	1,7	5	0,6
85	91,6	4,85	1,7	5	0,6
90	96,5	4,85	2,46	5	0,6
95	101,6	4,85	2,46	5	0,6
100	106,5	4,85	2,46	5	0,6
110	116,5	4,84	2,46	5	0,6
115	121,6	4,85	2,46	5	0,6
120	129,7	7,21	2,82	7	0,6
125	134,7	7,21	2,82	7	0,6
130	139,7	7,21	2,82	7	0,6

12.13.5

¹⁾ Dimensions D_2 and g apply for a retaining ring fit into the bearing

Weight 100 pcs.	Commerical designation	Designation of corresponding single row ball bearing			
		type			
		60	62	63	64
kg					
0,287	R32	6002N	6201N		
0,313	R35	6003N	6202N		
0,356	R40		6203N		
0,371	R42	6004N		6302N	
0,521	R47	6005N	6204N	6303N	
0,578	R52		6205N	6304N	
0,609	R55	6006N			
1,03	R62	6007N	6206N	6305N	6403N
1,36	R68	6008N			
1,44	R72		6207N	6306N	6404N
1,5	R75	6009N			
1,6	R80	6010N	6208N	6307N	6405N
1,7	R85		6209N		
2,67	R90	6011N	6210N	6308N	6406N
2,77	R95	6012N			
2,91	R100	6013N	6211N	6309N	6407N
3,2	R110	6014N	6212N	6310N	6408N
3,35	R115	6015N	6213N		
5,99	R120			6311N	6409N
6,24	R125	6016N	6214N		
6,48	R130	6017N	6215N	6312N	6410N



Snap rings for roller bearings with a groove on the outer ring

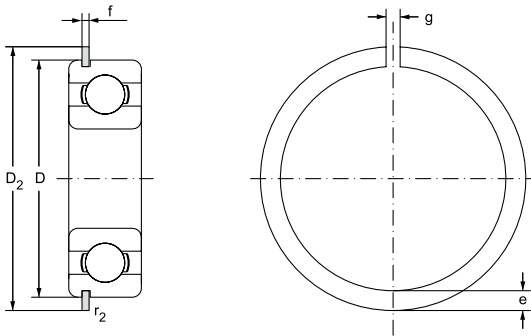

Main dimensions					
D	D ₂ ¹⁾	e	f	g ¹⁾	r ₂
	max	max	max	max	min
mm					
140	149,7	7,21	2,82	7	0,6
145	154,7	7,21	2,82	7	0,6
150	159,7	7,21	2,82	7	0,6
160	169,7	7,21	3,1	10	0,6
170	182,9	9,6	3,1	10	0,6
180	192,9	9,6	3,1	10	0,6
190	202,9	9,6	3,1	10	0,6
200	212,9	9,6	3,1	10	0,6

12.13.5

¹⁾ Dimensions D_2 and g apply for a retaining ring fit into the bearing

Weight 100 pcs.	Commerical designation	Designation of corresponding single row ball bearing			
		type			
		60	62	63	64
kg					
6,98	R140	6018N	6216N	6313N	6411N
7,23	R145	6019N	6217N		
7,48	R150	6020N		6314N	6412N
7,98	R160	6021N	6218N	6315N	6413N
12,4	R170	6022N	6219N	6316N	
13,2	R180	6024N	6220N	6317N	6414N
13,9	R190		6221N	6318N	6415N
14,6	R200	6026N	6222N	6319N	6416N



Clamp bearings $d = 20$ to 40 mm

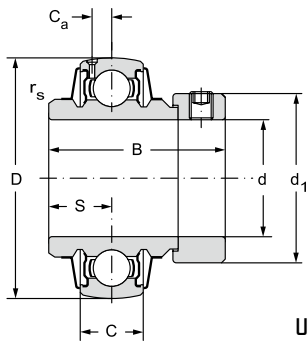

UA

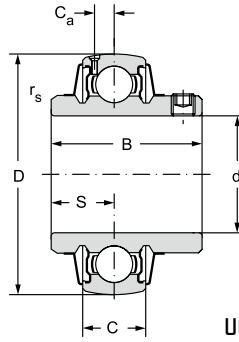

UC

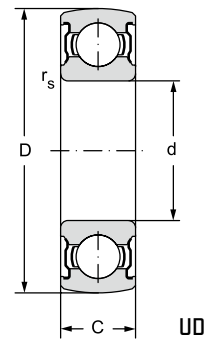

UD

12.13.6

Main dimensions								Basic load rating	
d	D	B	C	r_s	d_1	S	C_a	dynamic C_r	static C_{or}
				min	max				
mm								kN	
20	47	31,4	14	1		12,7	4,1	12,77	6,56
25	52	44,4	15	1	38	17,5	4,1	14	7,9
	52	34,1	15	1		14,3	4,1	14	7,9
	52		15	1		7,5		14	7,9
	52	31	15	0,6	38	7,5		14	7,9
	52	27,7	15	1		7,5		14	7,9
30	62	48,4	16	1	45	18,3	4,8	19,4	11,2
	62	38,1	16	1		15,9	4,8	19,4	11,2
	62		16	1		8		19,4	11,2
	62	35,7	16	0,6	45	8		19,4	11,2
	62	30,3	16	1		8		19,4	11,2
35	72	51,1	17	1,1	56,5	18,8	5,3	25,6	15,2
	72	42,9	17	1,1		17,5	5,3	25,6	15,2
	72		17	1,1		8,5		25,6	15,2
	72	38,9	17	0,6	56,5	9,5		25,6	15,2
	72	34	17	1,1		8,5		25,6	15,2
40	80	56,3	18	1,1	60	21,4	5,9	32,6	19,8
	80	49,2	18	1,1		19	5,9	32,6	19,8
	80		18	1,1		9		32,6	19,8
	80	43,7	18	0,6	60	11		32,6	19,8
	80	39,5	18	1,1		9		32,6	19,8

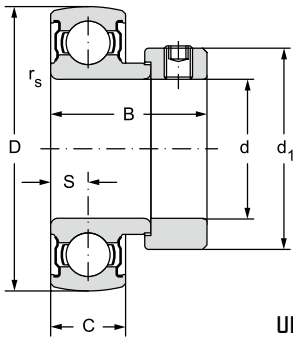

UE

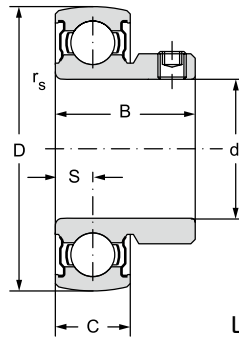

US

Bearing designation	Weight	Limiting speed for lubrication				
		Shaft diameter tolerance				
		h6	h7	h8	h9	h11
	kg	min ⁻¹				
UC204	0,146	8500	5300	3800	1300	850
UA205	0,23	7100	4500	3200	1000	710
UC205	0,17	7100	4500	3200	1000	710
UD205	0,126					
UE205	0,18	7100	4500	3200	1000	710
US205	0,15	7100	4500	3200	1000	710
UA206	0,36	6300	4000	2800	890	630
UC206	0,28	6300	4000	2800	890	630
UD206	0,195					
UE206	0,28	6300	4000	2800	890	630
US206	0,21	6300	4000	2800	890	630
UA207	0,55	5300	3300	2200	750	530
UC207	0,41	5300	3300	2200	750	530
UD207	0,278					
UE207	0,42	5300	3300	2200	750	530
US207	0,33	5300	3300	2200	750	530
UA208	0,7	4700	3000	1900	670	470
UC208	0,55	4700	3000	1900	670	470
UD208	0,36					
UE208	0,57	4700	3000	1900	670	470
US208	0,45	4700	3000	1900	670	470



Upright location units with clamp ring $d = 25$ to 40 mm

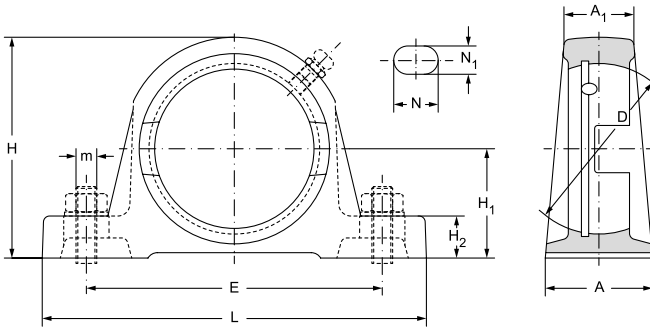

SG

12.13.7

Main dimensions											
d	D	L	E	H	H ₁	H ₂	A	A ₁	N	N ₁	m
mm											
25	52	130	102	70,5	36,5	14	34	22	17	12	M10
	52	130	102	70,5	36,5	14	34	22	17	12	M10
30	62	155	118	84	42,9	17	39	24	20	15	M12
	62	155	118	84	42,9	17	39	24	20	15	M12
35	72	160	128	93	47,6	19	44	29	20	15	M12
	72	160	128	93	47,6	19	44	29	20	15	M12
40	80	175	133	100	49,2	19	50	32	20	15	M12
	80	175	133	100	49,2	19	50	32	20	15	M12

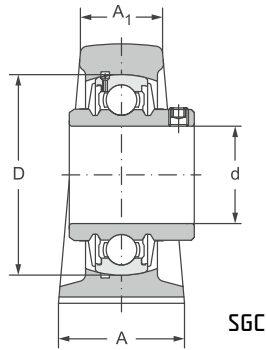
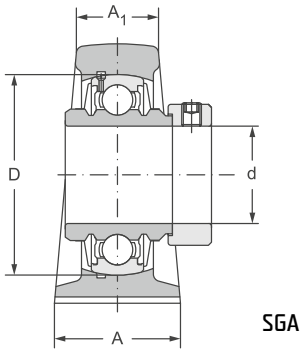

When using UE type bearings in SG hubs, the hub unit designation is SGE
 When using US type bearings in SG hubs, the hub unit designation is SGS

Basic load rating		Designation of			Weight
dynamic C_r	static C_{or}	unit	housing	bearing	
kN					kg
14	7,94	SGA205	SG205	UA205	0,74
14	7,94	SGC205	SG205	UC205	0,68
19,4	11,2	SGA206	SG206	UA206	1,2
19,4	11,2	SGC206	SG206	UC206	1,12
25,6	15,2	SGA207	SG207	UA207	1,6
25,6	15,2	SGC207	SG207	UC207	1,46
32,6	19,8	SGA208	SG208	UA208	1,95
32,6	19,8	SGC208	SG208	UC208	1,8



Four row flanged location units with clamp ring $d = 25$ to 40 mm

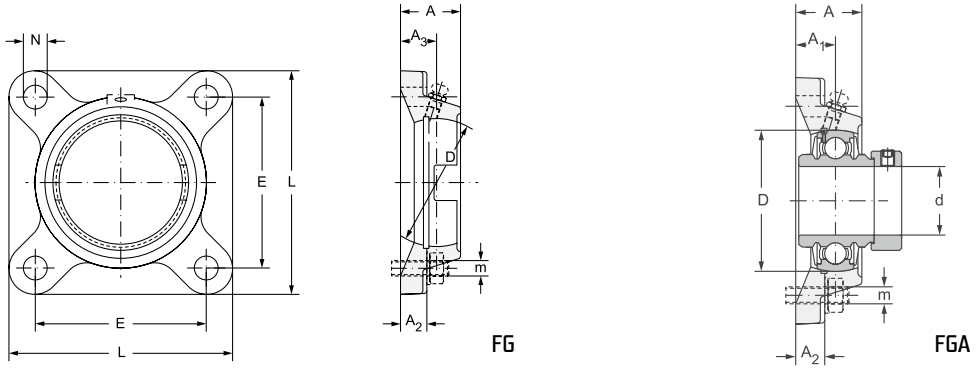

Main dimensions									
d	D	L	E	A	A ₁	A ₂	A ₃	N	m
mm									
25	52	95	70	45,9	29,5	13	19	12	M10
	52	95	70	38,8	29,5	13	19	12	M10
30	62	108	82,5	50,1	31	13	20	12	M10
	62	108	82,5	42,2	31	13	20	12	M10
35	72	118	92	52,8	33,5	14	20,5	15	M12
	72	118	92	45,9	33,5	14	20,5	15	M12
40	80	130	101,5	57,9	36,5	14	23	15	M12
	80	130	101,5	53,5	36,5	14	23	15	M12

12.13.8

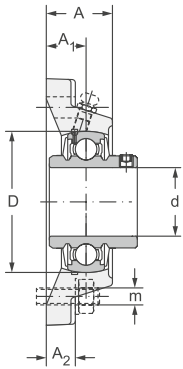

FGC

When using UE type bearings in FM hubs, the hub system designation is FME
 When using UD type bearings in FM hubs, the hub system designation is FMD
 When using US type bearings in FM hubs, the hub system designation is FMS

Basic load rating		Weight	Designation of		
dynamic C_r	static C_{or}		unit	housing	bearing
kN		kg			
14	7,9	0,83	FGA205	FG205	UA205
14	7,9	0,77	FGC205	FG205	UC205
19,4	11,2	1,2	FGA206	FG206	UA206
19,4	11,2	1,12	FGC206	FG206	UC206
25,6	15,2	1,55	FGA207	FG207	UA207
25,6	15,2	1,41	FGC207	FG207	UC207
32,6	19,8	2,05	FGA208	FG208	UA208
32,6	19,8	1,9	FGC208	FG208	UC208



Oval shaped flanged location units with clamp ring $d = 25$ to 40 mm

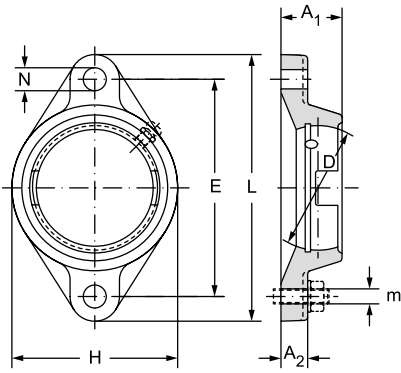

FM

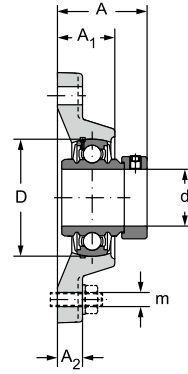

FMA

12.13.9

Main dimensions									
d	D	L	H	E	A	A ₁	A ₂	N	m
mm									
25	52	123	70	99	45,9	29,5	13	12	M10
	52	123	70	99	38,8	29,5	13	12	M10
30	62	142	83	116,5	50,1	31	13	12	M10
	62	142	83	116,5	42,2	31	13	12	M10
35	72	156	92	130	53,3	33,5	14	14	M12
	72	156	92	130	46,4	33,5	14	14	M12
40	80	172	102	143,8	58,9	37	14	15	M12
	80	172	102	143,8	54,2	37	14	15	M12

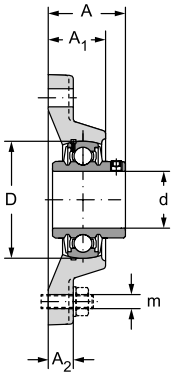

FMC

When using UE type bearings in FM hubs, the hub system designation is FME
 When using UD type bearings in FM hubs, the hub system designation is FMD
 When using US type bearings in FM hubs, the hub system designation is FMS

Basic load rating		Weight	Designation of		
dynamic C_r	static C_{or}		unit	housing	bearing
kN		kg			
14	7,9	0,64	FMA205	FM205	UA205
14	7,9	0,58	FMC205	FM205	UC205
14,4	11,2	1,08	FMA206	FM206	UA206
14,4	11,2	1	FMC206	FM206	UC206
25,6	15,2	1,45	FMA207	FM207	UA207
25,6	15,2	1,31	FMC207	FM207	UC207
32,6	19,8	1,75	FMA208	FM207	UA208
32,6	19,8	1,6	FMC208	FM207	UC208



Triangular pressed flanged location units with clamp bearing

d = 25 to 35 mm

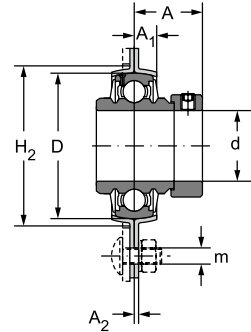
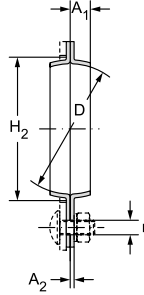
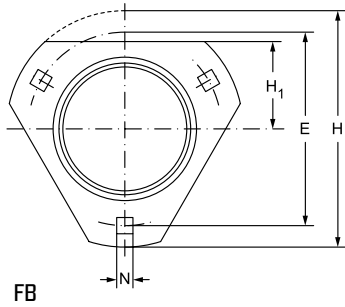

FB

FBA

Main dimensions										
d	D	H	E	H ₁	H ₂	A	A ₁	A ₂	N	m
mm										
25	52	99,5	76	34,5	60	26,9	9	2	8,8	M8
	52	99,5	76	34,5	60	19,8	9	2	8,8	M8
30	62	112,5	90,5	38,5	71	30,1	9,5	2,5	10,5	M10
	62	112,5	90,5	38,5	71	22,2	9,5	2,5	10,5	M10
35	72	122	100	45	81	32,3	10	2,5	10,5	M10
	72	122	100	45	81	24,1	10	2,5	10,5	M10

12.13.10

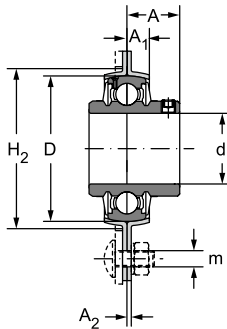

FBC

When using UE type bearings in FB hubs, the hub system designation is FBE
 When using UD type bearings in FB hubs, the hub system designation is FBD
 When using US type bearings in FB hubs, the hub system designation is FBS

Basic load rating		Weight	Designation of		
dynamic C_r	static C_{or}		unit	housing	bearing
kN		kg			
14	7,9	0,36	FBA205	FB205	UA205
14	7,9	0,3	FBC205	FB205	UC205
19,4	11,2	0,58	FBA206	FB206	UA206
19,4	11,2	0,5	FBC206	FB206	UC206
25,6	15,2	0,81	FBA207	FB207	UA207
25,6	15,2	0,67	FBC207	FB207	UC207



Round pressed flanged location units with clamp bearing $d = 20$ to 35 mm

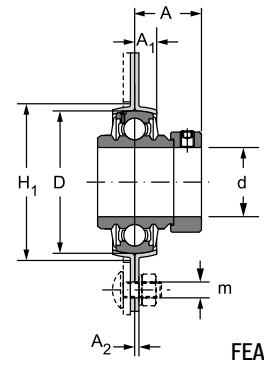
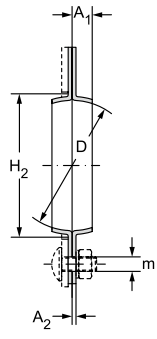
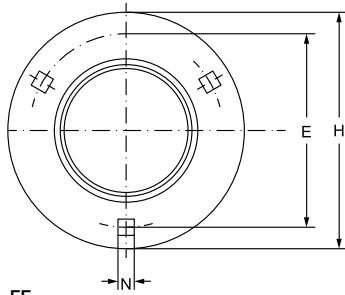

Main dimensions									
d	D	H	E	H ₂	A	A ₁	A ₂	N	m
mm									
20	47	91	71,5	55	18,3	8	2	8,7	M8
25	52	95	76	60	26,9	8,5	2	8,7	M8
	52	95	76	60	19,8	8,5	2	8,7	M8
30	62	112,7	90,5	71	30,1	8,7	2,5	10,5	M10
	62	112,7	90,5	71	22,2	8,7	2,5	10,5	M10
35	72	122	100	81	32,3	9,5	2,5	10,5	M10
	72	122	100	81	24,1	9,5	2,5	10,5	M10

12.13.11

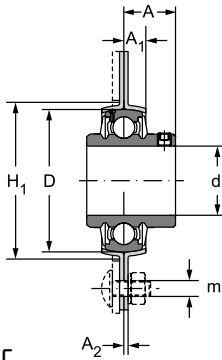

FEC

When using UE type bearings in FE hubs, the hub system designation is FEE
 When using UD type bearings in FE hubs, the hub system designation is FED
 When using US type bearings in FE hubs, the hub system designation is FES

Basic load rating		Weight	Designation of		
dynamic C_r	static C_{or}		unit	housing	bearing
kN		kg			
12,7	6,5	0,27	FEC204	FE204	UC204
14	7,9	0,4	FEA205	FE205	UA205
14	7,9	0,35	FEC205	FE205	UC205
19,4	11,2	0,65	FEA206	FE206	UA206
19,4	11,2	0,55	FEC206	FE206	UC206
25,6	15,2	0,86	FEA207	FE207	UA207
25,6	15,2	0,86	FEC207	FE207	UC207



Upright sheet metal location units with clamp bearing $d = 25$ to 35 mm

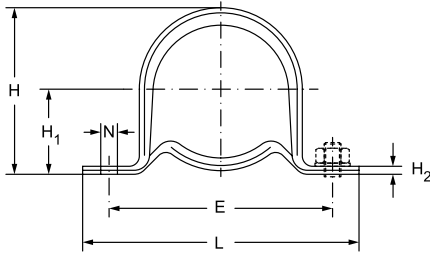

SA

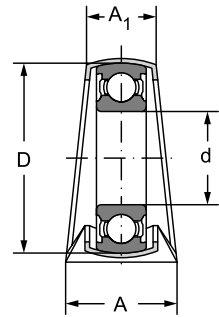
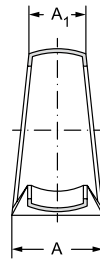

SAD

12.13.12

Main dimensions									
d	D	A	A ₁	E	L	H	H ₁	H ₂	N
mm									
25	52	32	21,5	86	108	56,6	28,6	4	11,2
30	62	38	23,8	95	119	66,3	33,3	4	11,2
35	72	42	27	106	130	78,2	39,7	5	11,2

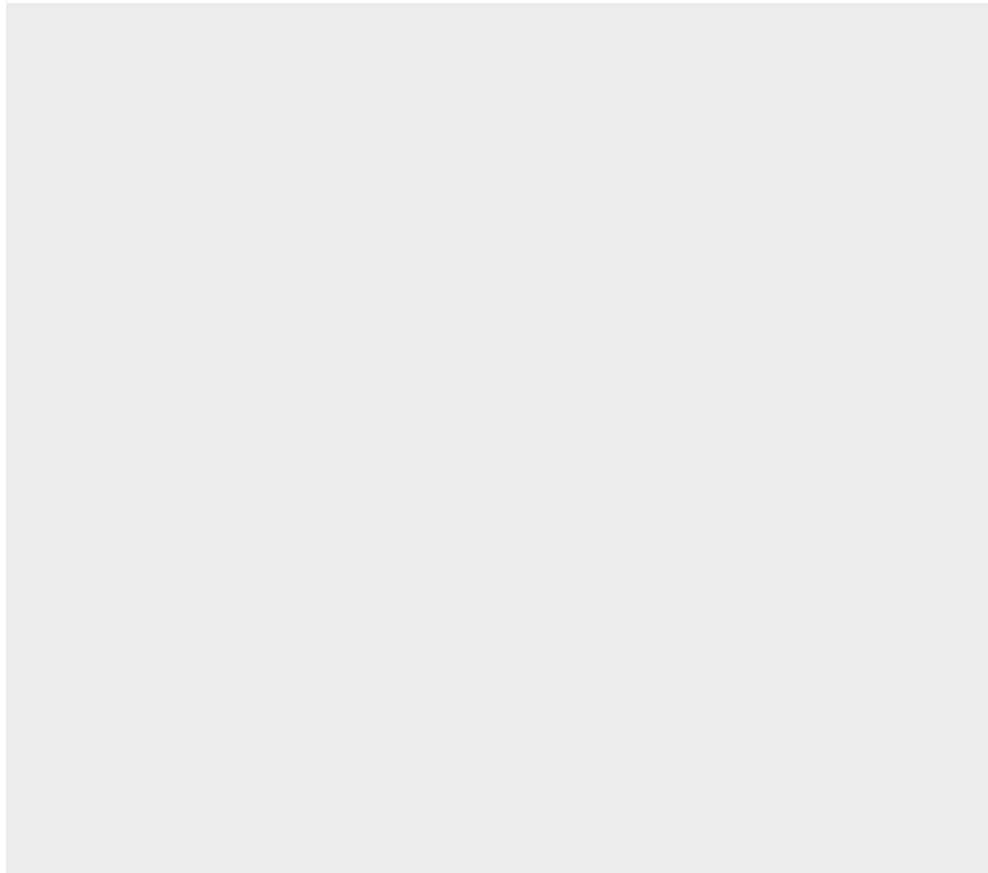

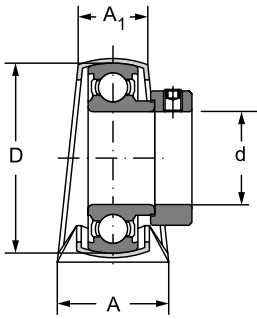

SAE

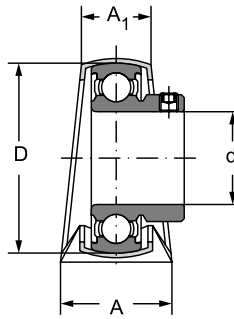

SAS

SAD type hub assemblies use UD bearings
 SAE type hub assemblies use UE bearings
 SAS type hub assemblies use US bearings

Basic load rating		Weight	Designation of			
dynamic C_r	static C_{or}		housing	housing with bearing		
kN		kg				
14	7,9	0,33	SA205	SAD205	SAE205	SAS205
19,4	11,2	0,53	SA206	SAD206	SAE206	SAS206
25,6	15,2	0,81	SA207	SAD207	SAE207	SAS207



Roller bearings

ZKL Edition 3/16/EN

